



**HIGHLY FLEXIBLE
COUPLINGS FOR
CARDAN SHAFTS**
SOLUTIONS FOR NEW TECHNOLOGIES





DECADES OF EXPERIENCE

Across Industries and Applications



Founded in 1932, Stromag™ has grown to become a globally recognized leader in the development and manufacture of innovative power transmission components for industrial drivetrain applications.

Stromag engineers utilize the latest design technologies and materials to provide creative, energy-efficient solutions that meet their customer's most challenging requirements.

Stromag's extensive product range includes flexible couplings, disc brakes, limit switches, an array of hydraulically, pneumatically, and electrically actuated brakes, and a complete line of electric, hydraulic and pneumatic clutches.

Stromag engineered solutions improve drivetrain performance in a variety of key markets including energy, off-highway, metals, marine, transportation, printing, textiles, and material handling on applications such as wind turbines, conveyor systems, rolling mills, agriculture and construction machinery, municipal vehicles, forklifts, cranes, presses, deck winches, diesel engines, gensets and stage machinery.

VISIT US ON THE WEB AT STROMAG.COM



CONTENT

Highly Flexible Couplings for Cardan Shafts: v

COUPLING AT A GLANCE	4
Product range	
Benefits include	
Application areas	
Fail-safe device	
Classifications	
Torque range	
Instructions for the designer	
The torsional vibration analysis	
STROMAG PERIFLEX® CS SERIES	10
Output table	10
Dimension table	11
AFL/PVN SERIES	19
Output table	20
Dimension table	21
IGE...FG SERIES	22
Output table	22
Dimension table	23
Characteristic	24
Coupling Design, question sheet	26

FLEXIBLE COUPLINGS

COUPLING AT A GLANCE

PERIFLEX® CS PRODUCT RANGE

PERIFLEX® CS SERIES

Nominal torque range: 560 – 14800 Nm



EXTERNAL



INTERNAL

AFL / PERIFLEX®VN SERIES

Nominal torque range: 1000 – 20000 Nm



IGE...FG SERIES

Nominal torque range: 4000 – 25000 Nm



BENEFITS INCLUDE

STROMAG PERIFLEX® CS COUPLING

- Highly flexible rubber couplings with linear characteristic for connecting a cardan shaft directly to a diesel engine. •
- Deflection angle of the cardan shaft of up to 5°.
- The radial and axial forces generated by the cardan shaft are absorbed by an internal plain bearing and transmitted to the engine bearing.
- Torque range between 560 Nm to 14.800 Nm.

STROMAG IGE...FG

- Highly flexible rubber coupling with a progressive characteristic for connecting a cardan shaft directly to a diesel engine.
- Deflection angle of the cardan shaft of up to 5°.
- The radial and axial forces generated by the cardan shaft are absorbed by an internal plain bearing and transmitted to the engine bearing.
- Torque range between 4000 Nm to 25.000 Nm.

STROMAG AFL/PERIFLEX® VN FLANGE BEARING

- Highly flexible rubber disc coupling with a linear characteristic for connecting a cardan shaft directly to a diesel engine.
- Deflection angle of the cardan shaft of up to 10°.
- The radial and axial forces generated by the cardan shaft are absorbed by an integrated bell housing and transmitted to the engine housing.
- Torque range between 1000 Nm to 20.000 Nm.

FLEXIBLE COUPLINGS

COUPLING AT A GLANCE

APPLICATION AREAS



- The Highly Flexible Couplings for Cardan Shafts is designed for applications with piston engines. The outer part can be bolted directly to the flywheel of an engine. The cardan shaft is flange mounted to the B-side of the coupling.
- Other application fields are railway industry and engine test cells.

FAIL-SAFE DEVICE

Stromag cardan shaft couplings are available with a fail-safe device. A rupture in the flexible element causes claws to intermesh, forming a torsionally rigid, backlash connection between the drive and output sides. Temporary emergency operation is possible with limited torque. The permissible torques and speeds must be calculated separately on the basis of torsional vibrations transferred via a torsionally rigid structure.



CLASSIFICATIONS



For survey of the coupling by a classification society, the regulations of the society have to be adhered to. The coupling characteristics may differ from the definitions given in this catalogue. Accordingly prepared data sheets are available on request.

A number of classification societies prescribe fail-safe devices on ships main drives.

TORQUE RANGE

- Stromag Periflex® CS: 560 up to 14,800 Nm
- Stromag AFL/PVN: 1000 up to 20,000 Nm
- Stromag IGE...FG: 4000 up to 25,000 Nm

INSTRUCTIONS FOR THE DESIGNER

The Stromag cardan shaft coupling is comprised of the combination of an element made from flexible rubber material with a bearing for the secure absorption of the reaction forces applied by a connected cardan shaft.

Three different series of the cardan shaft couplings have been developed in order to satisfy the different requirements in relation to the system torque, torsional stiffness and reaction force.

The highly flexible Stromag Periflex® CS series designs are preferred for standard applications.

The IGE series from the established highly flexible Stromag GE coupling product family is used for applications with high impact loads.

The Stromag flange bearing (AFL) assembly with a disc coupling as a cardan shaft coupling is recommended for an angle of deflection greater than 5°.

The couplings can be used in a temperature range of between -50°C and +80°C. The flexible elements may heat up as a result of damping work and reach higher temperatures than the ambient temperature. When covering the coupling with a protective enclosure, bear this fact in mind to assure sufficient ventilation and heat dissipation.

Static and dynamic characteristic values are available for the Stromag cardan shaft couplings. These values can help in the choice of a coupling size which is suitable for the specific application. The key factors for this are the loads arising from the power transmitted and torsional vibrations. Stationary operating modes must be based on T_{KN} , T_{KW} and P_{KV} while T_{Kmax} values are to be used for nonstationary operating modes.

When suitably stored, rubber flexible elements maintain their characteristics for several years without change. The parts need to be stored against oxygen, ozone, heat, light, moisture and solvents. The temperature in the store should be between +10°C and +25°C. The relative humidity should not exceed 65%. Further details are given on DIN 7716 and ISO 2230.

FLEXIBLE COUPLINGS

COUPLING AT A GLANCE



THE TORSIONAL VIBRATION ANALYSIS

Stromag's Know-how in Torsional Vibration Analysis (TVA) constitutes the core of each coupling design. It provides a comprehensive analysis of loads in the crankshaft, coupling and driven side to ensure that no critical speeds occur during operation.

Unevenly rotating systems can severely degrade product quality and cause great harm to the powertrain. On a daily basis, the TVA experts at Stromag work on the challenge of detecting such deviations by measuring them and protecting the entire powertrain with ideal product selection. Stromag is capable of calculating stationary and transient operating conditions considering the stiffness and damping of the elastomers.

FLEXIBLE COUPLINGS

Stromag Periflex® CS Couplings

Periflex® CS Concept

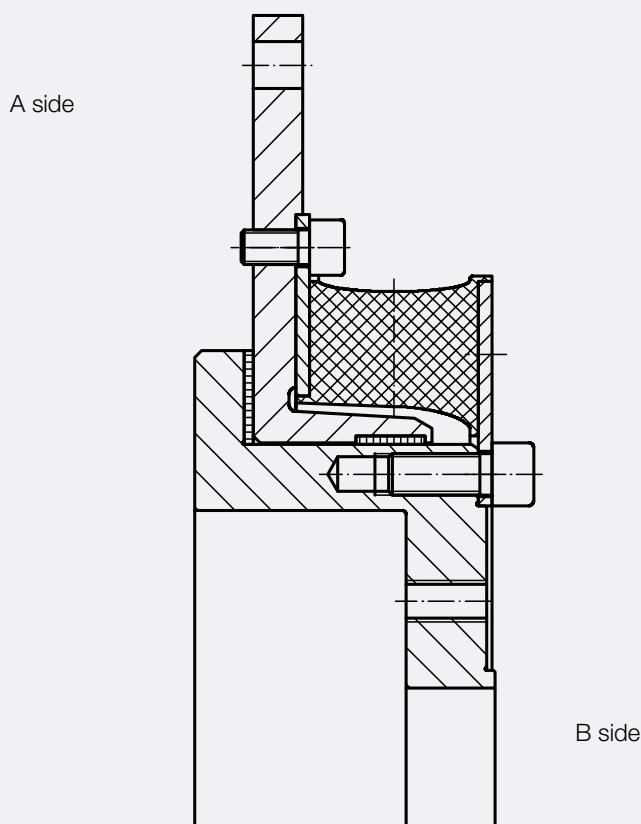

DD_880026 - 000

The Periflex® CS couplings are highly flexible rubber couplings with a linear spring characteristic for connecting a cardan shaft directly to a diesel engine drive. The ring element can be bolted directly to an engine's flywheel. The cardan shaft is flange-mounted to the B-side of the coupling. An deflection angle of the cardan shaft of up to 5° is generally permitted, larger angles are available on request.

The series covers the torque range from 560 to 14,800 Nm.

The connecting dimensions on the engine side primarily conform to SAE standard J620 or DIN 6281. The cardan shaft side is available in a range of metric sizes, including for Spicer, Mechanics or cross-toothed connections.

The Periflex® CS coupling is comprised of the combination of a ring element made from flexible rubber material with a bearing for the secure absorption of the reaction forces applied by a connected cardan shaft. The ring element is exclusively torsionally flexible. The bearing consists of an axial and radial plain bearing made from wear-free and maintenance-free composite material.

The metal parts of the Periflex® CS coupling are made from high-quality cast parts as standard. The ring element is manufactured from natural rubber (NR) in various rubber qualities and torsional stiffnesses. These allow precise adjustment to drives that are susceptible to torsional vibrations.

FLEXIBLE COUPLINGS

Stromag Periflex® CS Couplings

Stromag Periflex® CS output table									
Coupling Size	Element	Nominal Torque	Maximum Torque		Adm. Alternating Torque	Adm. Speed	Torsional Stiffness	Relative Damping	Adm. Damping Power
		T_{KN} Nm	T_{Kmax1} Nm 1)	T_{Kmax2} Nm 2)	T_{KW} Nm	n_{max} rpm	C_{Tdyn} kNm/rad 3) 4)	γ 3) 4)	P_{KV60} W 5)
CS 13	131	560	840	1680	140	4400	2.8	0.8	130
	132	700	1050	2100	175	4400	4.0	1.0	130
	133	900	1350	2700	225	4400	5.5	1.1	130
CS 21	211	700	1050	2100	175	4200	4.0	0.8	200
	212	900	1350	2700	225	4200	5.5	1.0	200
	213	1100	1650	3300	275	4200	7.7	1.1	200
CS 22	221	900	1350	2700	225	4200	4.7	0.8	220
	222	1100	1650	3300	275	4200	7.0	1.0	220
	223	1400	2100	4200	350	4200	9.1	1.1	220
CS 31	311	1300	1950	3900	325	3800	6.9	0.8	260
	312	1700	2550	5100	425	3800	9.5	1.0	260
	313	2000	3000	6000	500	3800	13.5	1.1	260
CS 32	321	1800	2700	5400	450	3800	10.5	0.8	340
	322	2200	3300	6600	550	3800	14.5	1.0	340
	323	2600	3900	7800	650	3800	20.0	1.1	340
CS 41	411	2300	3450	6900	575	2800	19.0	0.8	360
	412	3000	4500	9000	750	2800	28.5	1.0	360
	413	4000	6000	12000	1000	2800	34.5	1.1	360
CS 42	421	3500	5250	10500	875	2800	25.5	0.8	440
	422	3800	5700	11400	950	2800	34.5	1.0	440
	423	5200	7800	15600	1300	2800	42.0	1.1	440
CS 43	431	4400	6600	13200	1100	2800	32.5	0.8	510
	432	5600	8400	16800	1400	2800	42.5	1.0	510
	433	6700	10050	20100	1675	2800	57.5	1.1	510
CS 51	511	7200	10800	21600	1800	2300	60.0	0.8	580
	512	9400	14100	28200	2350	2300	82.5	1.0	580
	513	11400	17100	34200	2850	2300	105	1.1	580
CS 52	521	9800	14700	29400	2450	2300	90.0	0.8	630
	522	13000	19500	39000	3250	2300	100	1.0	630
	523	14800	22200	44400	3700	2300	146	1.1	630

- 1) For periodic, short-term vibrations during start-stop, switching, etc.
- 2) For rare peak loads, e.g. generator short-circuit
- 3) For: $T_w = 0.2 \cdot T_{KN}$; $T = 0.8 \cdot T_{KN}$; $f = 10$ Hz; $\vartheta = 30^\circ\text{C}$
- 4) Material-related tolerances as high as $\pm 15\%$ are possible.
- 5) The P_{KV60} value describes the damping performance that can be absorbed over 60 minutes.
Permanently absorbable damping performance $P_{KV\infty} = 0.5 \cdot P_{KV60}$

FLEXIBLE COUPLINGS

Stromag Periflex® CS Couplings

Stromag Periflex® CS dimension table

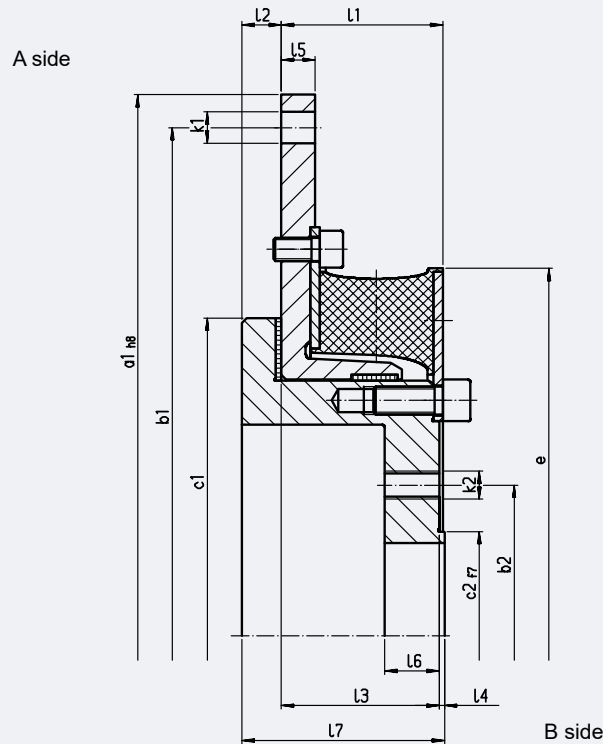

DD 880023 - 000

Metric, external cardan shaft connection

Size		CS 13						CS 21						CS 22					
SAE connection		8"			10"			10"			11½"			10"			11½"		
Cardan flange		75	90	100	75	90	100	90	100	120	90	100	120	90	100	120	90	100	120
Diameter mm	a ₁	263.5	263.5	263.5	314.4	314.4	314.4	314.4	314.4	314.4	352.4	352.4	352.4	314.4	314.4	314.4	352.4	352.4	352.4
	b ₁	244.5	244.5	244.5	295.3	295.3	295.3	295.3	295.3	295.3	333.4	333.4	333.4	295.3	295.3	295.3	333.4	333.4	333.4
	c ₁	200	200	200	200	200	200	200	200	200	200	200	200	200	200	200	200	200	200
	k ₁	6x11	6x11	6x11	8x11	8x11	8x11	8x11	8x11	8x11	8x11	8x11	8x11	8x11	8x11	8x11	8x11	8x11	8x11
	b ₂	62	74.5	84	62	74.5	84	74.5	84	101.5	74.5	84	101.5	74.5	84	101.5	74.5	84	101.5
	c ₂	42	47	57	42	47	57	47	57	75	47	57	75	47	57	75	47	57	75
	k ₂ *	6xM6	4xM8	6xM8	6xM6	4xM8	6xM8	4xM8	6xM8	8xM8	4xM8	6xM8	8xM8	4xM8	6xM8	8xM8	4xM8	6xM8	8xM8
	e	228	228	228	228	228	228	250	250	250	250	250	250	254	254	254	254	254	254
Lengths mm	l ₁	61.5	61.5	61.5	61.5	61.5	61.5	61.5	61.5	61.5	61.5	61.5	61.5	61.5	61.5	61.5	61.5	61.5	61.5
	l ₂	10.5	10.5	10.5	10.5	10.5	10.5	10.5	10.5	10.5	10.5	10.5	10.5	10.5	10.5	10.5	10.5	10.5	10.5
	l ₃	60	60	60	60	60	60	60	60	60	60	60	60	60	60	60	60	60	60
	l ₄	2	2.3	2.3	2	2.3	2.3	2.3	2.3	2.3	2.3	2.3	2.3	2.3	2.3	2.3	2.3	2.3	2.3
	l ₅	11.5	11.5	11.5	13.5	13.5	13.5	11.5	11.5	11.5	13.5	13.5	13.5	11.5	11.5	11.5	13.5	13.5	13.5
	l ₆	19	19	19	19	19	19	19	19	19	19	19	19	19	19	19	19	19	19
	l ₇	72.5	72.8	72.8	72.5	72.8	72.8	72.8	72.8	72.8	72.8	72.8	72.8	72.8	72.8	72.8	72.8	72.8	72.8
	l ₈																		
Mass moment of inertia kgm ²	J _{A side}	0.056	0.056	0.056	0.102	0.102	0.102	0.114	0.114	0.114	0.165	0.165	0.165	0.116	0.116	0.116	0.167	0.167	0.167
	J _{B side}	0.039	0.039	0.039	0.039	0.039	0.039	0.044	0.044	0.044	0.044	0.044	0.044	0.046	0.046	0.046	0.046	0.046	0.046
Mass kg	12.4	12.4	12.3	14.6	14.6	14.5	15.5	15.4	15.2	17.3	17.2	17.0	15.7	15.6	15.4	17.5	17.4	17.2	

FLEXIBLE COUPLINGS

Stromag Periflex® CS Couplings

Stromag Periflex® CS dimension table

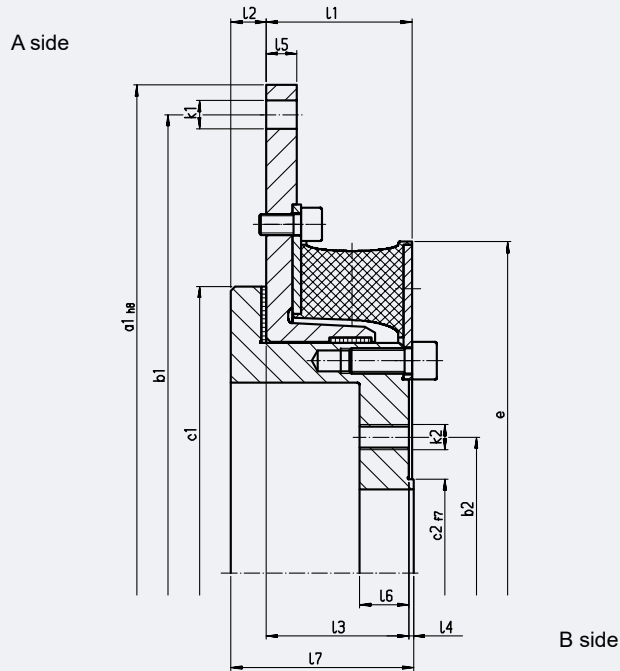

DD 880023 - 000

Metric, external cardan shaft connection

Size		CS 31						CS 32					
SAE connection		11 1/2"			14"			11 1/2"			14"		
Cardan flange		100	120	150	100	120	150	120	150	180	120	150	180
Diameter mm	a ₁	352.4	352.4	352.4	466.7	466.7	466.7	352.4	352.4	352.4	466.7	466.7	466.7
	b ₁	333.4	333.4	333.4	438.2	438.2	438.2	333.4	333.4	333.4	438.2	438.2	438.2
	c ₁	274	274	274	274	274	274	274	274	274	274	274	274
	k ₁	8x11	8x11	8x11	8x13.5	8x13.5	8x13.5	8x11	8x11	8x11	8x13.5	8x13.5	8x13.5
	b ₂	84	101.5	130	84	101.5	130	101.5	130	155.5	101.5	130	155.5
	c ₂	57	75	90	57	75	90	75	90	110	75	90	110
	k ₂	6xM8	8xM8	8xM10	6xM8	8xM8	8xM10	8xM8	8xM10	8xM14	8xM8	8xM10	8xM14
	e	314	314	314	314	314	314	317	317	317	317	317	317
Lengths mm	l ₁	69.5	69.5	69.5	69.5	69.5	69.5	69.5	69.5	69.5	69.5	69.5	69.5
	l ₂	17	17	17	17	17	17	17	17	17	17	17	17
	l ₃	68	68	68	68	68	68	68	68	68	68	68	68
	l ₄	2.3	2.3	2.3	2.3	2.3	2.3	2.3	2.3	2.3	2.3	2.3	2.5
	l ₅	12.5	12.5	12.5	14.5	14.5	14.5	12.5	12.5	12.5	14.5	14.5	14.5
	l ₆	23	23.5	23.5	23.5	23.5	23.5	23.5	23.5	23.5	23.5	23.5	23.5
	l ₇	87.3	87.3	87.3	87.3	87.3	87.3	87.3	87.3	87.3	87.3	87.3	87.3
Mass moment of inertia kgm ²	J _{A side}	0.187	0.187	0.187	0.511	0.511	0.511	0.121	0.191	0.191	0.515	0.515	0.515
	J _{B side}	0.166	0.165	0.165	0.166	0.165	0.165	0.169	0.169	0.168	0.169	0.169	0.168
Mass kg	25	24.8	24.5	32.5	32.3	32.3	25.5	25.2	25.2	33.0	32.7	32.2	

FLEXIBLE COUPLINGS

Stromag Periflex® CS Couplings

Stromag Periflex® CS dimension table

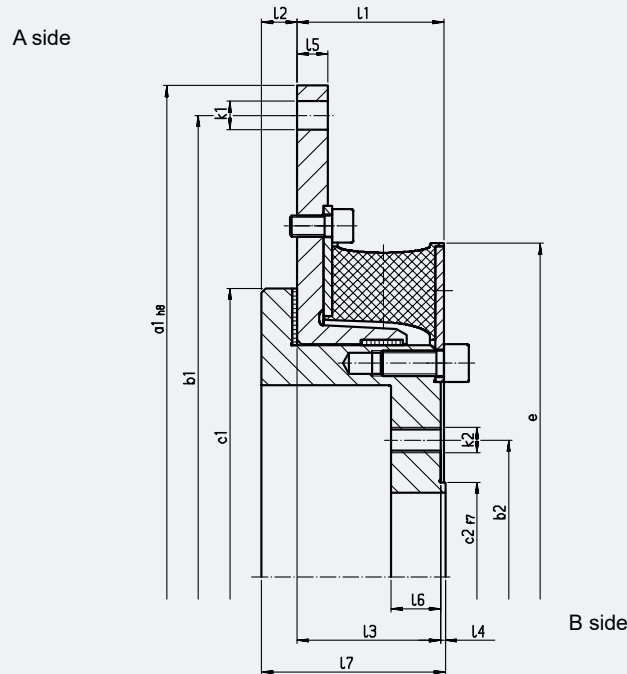

DD 880023 - 000

Metric, external cardan shaft connection

Size		CS 41			CS 42			CS 43								
SAE connection		14"			14"			14"			16"			18"		
Cardan flange		150	180	225	150	180	225	180	225	250	180	225	250	180	225	250
Diameter mm	a ₁	466.7	466.7	466.7	466.7	466.7	466.7	466.7	466.7	466.7	517.5	517.5	517.5	571.5	571.5	571.5
	b ₁	438.2	438.2	438.2	438.2	438.2	438.2	438.2	438.2	438.2	489	489	489	542.9	542.9	542.9
	c ₁	370	370	370	370	370	370	370	370	370	370	370	370	370	370	370
	k ₁	16x13.5	16x13.5	16x13.5	16x13.5	16x13.5	16x13.5	16x13.5	16x13.5	16x13.5	8x13.5	8x13.5	8x13.5	8x17.5	6x17.5	6x17.5
	b ₂	130	155.5	196	130	155.5	196	155.5	196	218	155.5	196	218	155.5	196	218
	c ₂	90	110	140	90	110	140	110	140	140	110	140	140	110	140	140
	k ₂	8xM10 8xM12	8xM14 10xM16	8xM16	8xM10 8xM12	8xM14 10xM16	8xM16	8xM14 10xM16	8xM16 10xM16	8xM18	8xM18	8xM14 10xM16	8xM16 8xM18	8xM14 10xM16	8xM14 10xM16	8xM16 8xM18
e	417	417	417	417	417	417	420	420	420	420	420	420	420	420	420	
Lengths mm	l ₁	76.5	76.5	76.5	76.5	76.5	76.5	76.5	76.5	76.5	76.5	76.5	76.5	76.5	76.5	76.5
	l ₂	19.0	19.0	19.0	19.0	19.0	19.0	19.0	19.0	19.0	19.0	19.0	19.0	19.0	19.0	19.0
	l ₃	74.5	74.5	74.5	74.5	74.5	74.5	74.5	74.5	74.5	74.5	74.5	74.5	74.5	74.5	74.5
	l ₄	2.3	2.3	4.5	2.3	2.3	4.5	2.3	4.5	5.5	2.3	4.5	5.5	2.3	4.5	5.5
	l ₅	14.5	14.5	14.5	14.5	14.5	14.5	14.5	14.5	14.5	16.5	16.5	16.5	16.5	16.5	16.5
	l ₆	27.0	27	27	27	27	27	27	27	27	27	27	27	27	27	27
	l ₇	95.8	95.8	98	95.8	95.8	98	95.8	98	95.8	95.8	95.8	98	95.8	98	99
Mass moment of inertia kgm ²	J _{A side}	0.646	0.646	0.646	0.657	0.657	0.657	0.666	0.666	0.666	0.936	0.936	0.936	1.346	1.346	1.346
	J _{B side}	0.627	0.626	0.623	0.638	0.637	0.633	0.646	0.643	0.643	0.646	0.643	0.643	0.646	0.643	0.643
Mass kg		50.5	49.9	48.9	51.5	50.5	49.5	50.9	49.9	49.9	55.3	54.3	54.3	60.9	59.9	59.9

FLEXIBLE COUPLINGS

Stromag Periflex® CS Couplings

Stromag Periflex® CS dimension table

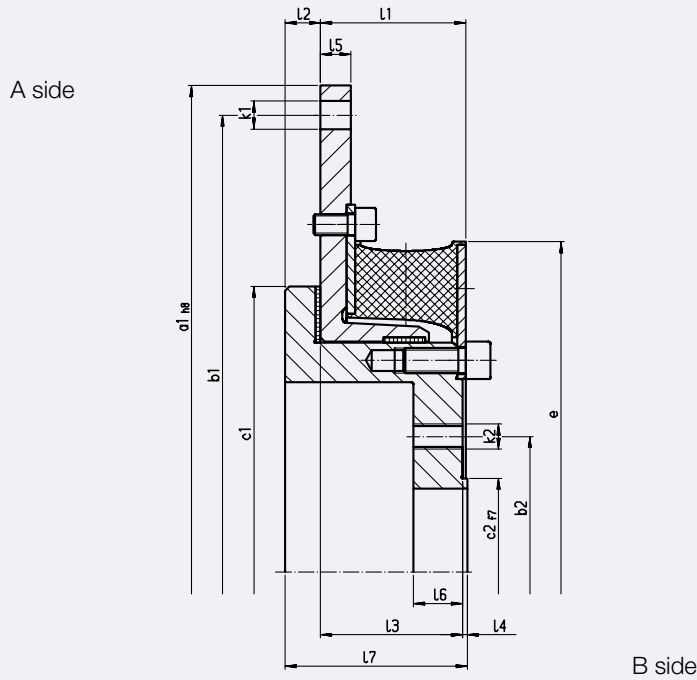

DD 880023 - 000

Metric, external cardan shaft connection

Size		CS 51			CS 52	
SAE connection		18"			21"	
Cardan flange		225	250	285	250	285
Diameter mm	a ₁	571.5	571.5	571.5	673.1	673.1
	b ₁	542.9	542.9	542.9	641.4	641.4
	c ₁	440	440	440	440	440
	k ₁	12x17.5	12x17.5	12x17.5	12x17.5	12x17.5
	b ₂	196	218	245	218	245
	c ₂	140	140	175	140	175
	k ₂	8xM16	8xM18	8xM20	8xM18	8xM20
	e	520	520	520	525	525
Lengths mm	l ₁	93	93	93	93	93
	l ₂	21	21	21	21	21
	l ₃	90	90	90	90	90
	l ₄	4.5	5.5	5.5	5.5	5.5
	l ₅	16.0	16.0	16.0	16.0	16.0
	l ₆	30.5	30.5	30.5	30.5	30.5
	l ₇	115.5	116.5	116.5	116.5	116.5
Mass moment of inertia kgm ²	J _{A side}	1.745	1.745	1.745	3.380	3.380
	J _{B side}	1.514	1.514	1.505	1.569	1.559
Mass kg		85.3	85.4	83.6	103.2	101.4

FLEXIBLE COUPLINGS

Stromag Periflex® CS Couplings

Stromag Periflex® CS dimension table

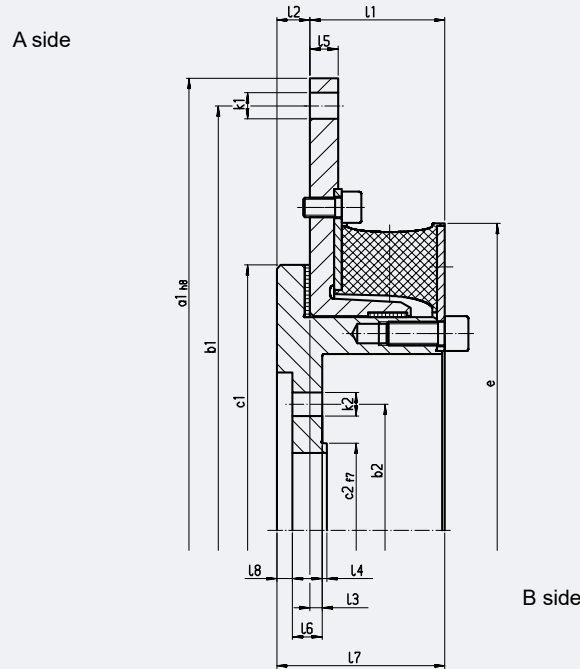

DD 880024 – 000

Metric, internal cardan shaft connection

Size		CS 13						CS 21						CS 22					
SAE connection		8"			10"			10"			11 1/2"			10"			11 1/2"		
Cardan flange		75	90	100	75	90	100	90	100	120	90	100	120	90	100	120	90	100	120
Diameter mm	a ₁	263.5	263.5	263.5	314.4	314.4	314.4	314.4	314.4	314.4	352.4	352.4	352.4	314.4	314.4	314.4	352.4	352.4	352.4
	b ₁	244.5	244.5	244.5	295.3	295.3	295.3	295.3	295.3	295.3	333.4	333.4	333.4	295.3	295.3	295.3	333.4	333.4	333.4
	c ₁	200	200	200	200	200	200	200	200	200	200	200	200	200	200	200	200	200	200
	k ₁	6x11	6x11	6x11	8x11	8x11	8x11	8x11	8x11	8x11	8x11	8x11	8x11	8x11	8x11	8x11	8x11	8x11	8x11
	b ₂	62	74.5	84	62	74.5	84	74.5	84	101.5	74.5	84	101.5	74.5	84	101.5	74.5	84	101.5
	c ₂	42	47	57	42	47	57	47	57	75	47	57	75	47	57	75	47	57	75
	k ₂ *	6x6.1	4x8.1	6x8.1	6x6.1	4x8.1	6x8.1	4x8.1	6x8.1	8x8.1	4x8.1	6x8.1	8x8.1	4x8.1	6x8.1	8x8.1	4x8.1	6x8.1	8x8.1
	e	228	228	228	228	228	228	250	250	250	250	250	250	254	254	254	254	254	254
Lengths mm	l ₁	61.5	61.5	61.5	61.5	61.5	61.5	61.5	61.5	61.5	61.5	61.5	61.5	61.5	61.5	61.5	61.5	61.5	61.5
	l ₂	10.5	10.5	10.5	10.5	10.5	10.5	10.5	10.5	10.5	10.5	10.5	10.5	10.5	10.5	10.5	10.5	10.5	10.5
	l ₃	11.5	11.5	11.5	11.5	11.5	11.5	11.5	11.5	11.5	11.5	11.5	11.5	11.5	11.5	11.5	11.5	11.5	11.5
	l ₄	2.0	2.3	2.3	2.0	2.3	2.3	2.3	2.3	2.3	2.3	2.3	2.3	2.3	2.3	2.3	2.3	2.3	2.3
	l ₅	11.5	11.5	11.5	13.5	13.5	13.5	11.5	11.5	11.5	13.5	13.5	13.5	11.5	11.5	11.5	13.5	13.5	13.5
	l ₆	17.3	16.0	16.0	17.3	16.0	16.0	16.0	16.0	16.0	16.0	16.0	16.0	16.0	16.0	16.0	16.0	16.0	16.0
	l ₇	72.0	72.0	72.0	72.0	72.0	72.0	72.0	72.0	72.0	72.0	72.0	72.0	72.0	72.0	72.0	72.0	72.0	72.0
	l ₈	4.7	6.0	6.0	4.7	6.0	6.0	6.0	6.0	6.0	6.0	6.0	6.0	6.0	6.0	6.0	6.0	6.0	6.0
Mass moment of inertia kgm ²	J _{A side}	0.056	0.056	0.056	0.102	0.102	0.102	0.114	0.114	0.114	0.165	0.165	0.165	0.116	0.116	0.116	0.167	0.167	0.167
	J _{B side}	0.039	0.039	0.039	0.039	0.039	0.039	0.044	0.044	0.044	0.044	0.044	0.044	0.046	0.046	0.045	0.046	0.046	0.046
Mass kg		12.5	12.3	12.2	14.7	14.5	14.4	15.5	15.3	15.0	17.3	17.1	16.8	15.7	15.5	15.2	17.5	17.3	17.0

FLEXIBLE COUPLINGS

Stromag Periflex® CS Couplings

Stromag Periflex® CS dimension table

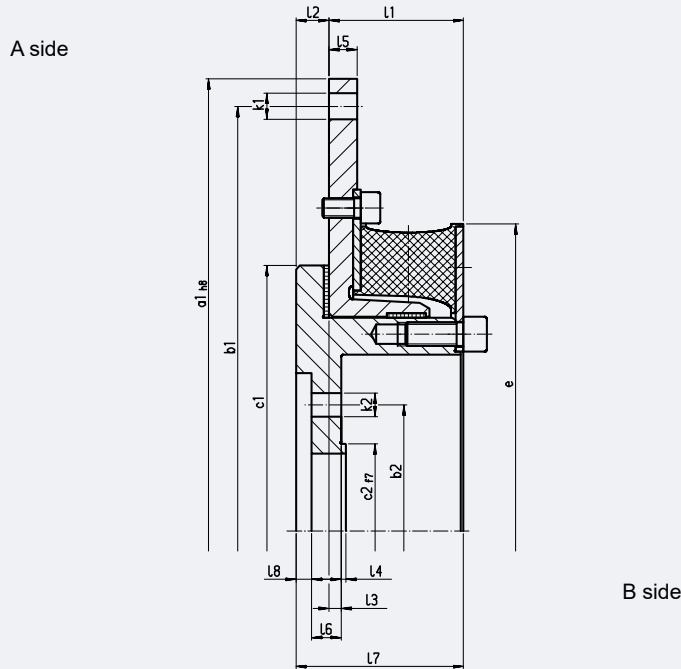

DD 880024 – 000

Metric, internal cardan shaft connection

Size		CS 31						CS 32					
SAE connection		11 1/2"			14"			11 1/2"			14"		
Cardan flange		100	120	150	100	120	150	120	150	180	120	150	180
Diameter mm	a ₁	352.4	352.4	352.4	466.7	466.7	466.7	352.4	352.4	352.4	466.7	466.7	466.7
	b ₁	333.4	333.4	333.4	438.2	438.2	438.2	333.4	333.4	333.4	438.2	438.2	438.2
	c ₁	274	274	274	274	274	274	274	274	274	274	274	274
	k ₁	8x11	8x11	8x11	8x13.5	8x13.5	8x13.5	8x11	8x11	8x11	8x13.5	8x13.5	8x13.5
	b ₂	84	101.5	130	84	101.5	130	101.5	130	155.5	101.5	130	155.5
	c ₂	57	75	90	57	75	90	75	90	110	75	90	110
	k ₂	6x8.1	8x8.1	8x10.1	6x8.1	8x8.1	8x10.1	8x8.1	8x10.1	8x14.1	8x8.1	8x10.1	8x14.1
	e	314	314	314	314	314	314	317	317	317	317	317	317
Lengths mm	l ₁	69.5	69.5	69.5	69.5	69.5	69.5	69.5	69.5	69.5	69.5	69.5	69.5
	l ₂	17	17	17	17	17	17	17	17	17	17	17	17
	l ₃	9.5	9.5	9.5	9.5	9.5	9.5	9.5	9.5	9.5	9.5	9.5	9.5
	l ₄	2.3	2.3	2.3	2.3	2.3	2.3	2.3	2.3	2.3	2.3	2.3	2.3
	l ₅	12.5	12.5	12.5	14.5	14.5	14.5	12.5	12.5	12.5	14.5	14.5	14.5
	l ₆	20.5	20.5	19.5	20.5	20.5	19.5	20.5	19.5	17.5	20.5	19.5	17.5
	l ₇	86.5	86.5	86.5	86.5	86.5	86.5	86.5	86.5	86.5	86.5	86.5	86.5
	l ₈	6.0	6.0	7.0	6.0	6.0	7.0	6.0	7.0	9.0	6.0	7.0	9.0
Mass moment of inertia kgm ²	J _{A side}	0.187	0.187	0.187	0.511	0.511	0.511	0.191	0.191	0.191	0.515	0.515	0.515
	J _{B side}	0.167	0.167	0.164	0.167	0.167	0.164	0.171	0.168	0.162	0.171	0.168	0.162
Mass kg		25.1	24.7	24.1	32.7	32.2	31.6	25.4	24.8	23.6	32.9	32.3	31.1

FLEXIBLE COUPLINGS

Stromag Periflex® CS Couplings

Stromag Periflex® CS dimension table

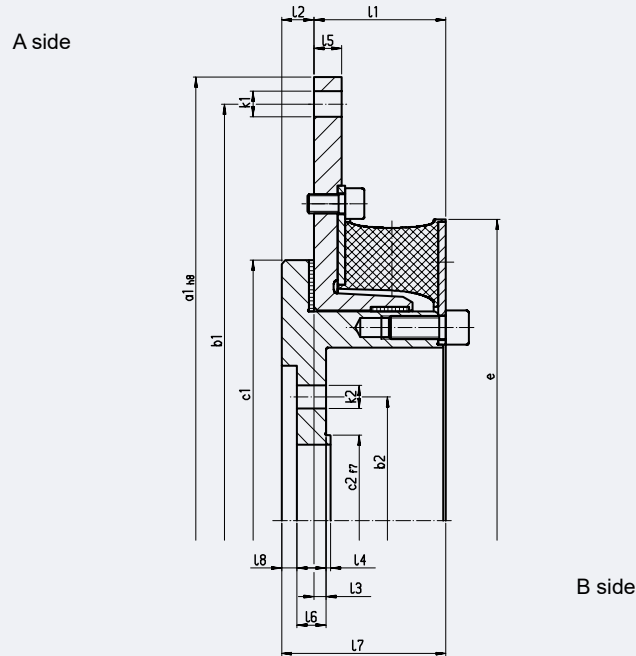

DD 880024 – 000

Metric, internal cardan shaft connection

Size		CS 41			CS 42			CS 43						
SAE connection		14"			14"			14"		16"		18"		
Cardan flange		150	180	225	150	180	225	180	225	180	225	180	225	
Diameter mm	a ₁	466.7	466.7	466.7	466.7	466.7	466.7	466.7	466.7	517.5	517.5	571.5	571.5	
	b ₁	438.2	438.2	438.2	438.2	438.2	438.2	438.2	438.2	489	489	542.9	542.9	
	c ₁	370	370	370	370	370	370	370	370	370	370	370	370	
	k ₁	16x13.5	16x13.5	16x13.5	16x13.5	16x13.5	16x13.5	16x13.5	16x13.5	8x13.5	8x13.5	6x17.5	6x17.5	
	b ₂	130	155.5	196	130	155.5	196	155.5	196	155.5	196	155.5	196	
	c ₂	90	110	140	90	110	140	110	140	110	140	110	140	
	k ₂	8x10.1 8x12.1	8x14.1 10x16.1	8x16.1	8x10.1 8x12.1	8x14.1 10x16.1	8x16.1	8x14.1 10x16.1	8x16.1	8x14.1 10x16.1	8x14.1 10x16.1	8x16.1	8x14.1 10x16.1	8xM16
	e	417	417	417	420	420	420	420	420	420	420	420	420	
Lengths mm	l ₁	76.5	76.5	76.5	76.5	76.5	76.5	76.5	76.5	76.5	76.5	76.5	76.5	
	l ₂	19.0	19.0	19.0	19.0	19.0	19.0	19.0	19.0	19.0	19.0	19.0	19.0	
	l ₃	12.0	12.0	12.0	12.0	12.0	12.0	12.0	12.0	12.0	12.0	12.0	12.0	
	l ₄	2.3	2.3	4.5	2.3	2.3	4.5	2.3	4.5	2.3	4.5	2.3	4.5	
	l ₅	14.5	14.5	14.5	14.5	14.5	14.5	14.5	14.5	16.5	16.5	16.5	16.5	
	l ₆	24.0	22.0	20.5	24.0	22.0	20.5	22.0	20.5	22.0	20.5	22.0	20.5	
	l ₇	95.5	95.5	95.5	95.5	95.5	95.5	95.5	95.5	95.5	95.5	95.5	95.5	
	l ₈	7.0	9.0	10.5	7.0	9.0	10.5	9.0	10.5	9.0	10.5	9.0	10.5	
Mass moment of inertia kgm ²	J _{A side}	0.646	0.646	0.646	0.657	0.657	0.657	0.666	0.666	0.936	0.936	1.346	1.346	
	J _{B side}	0.634	0.628	0.611	0.645	0.638	0.622	0.648	0.631	0.648	0.632	0.648	0.645	
Mass kg		50.9	49.7	47.6	51.5	50.3	48.2	50.7	48.6	55.1	53.0	60.7	60.4	

FLEXIBLE COUPLINGS

Stromag Periflex® CS Couplings

Stromag Periflex® CS dimension table

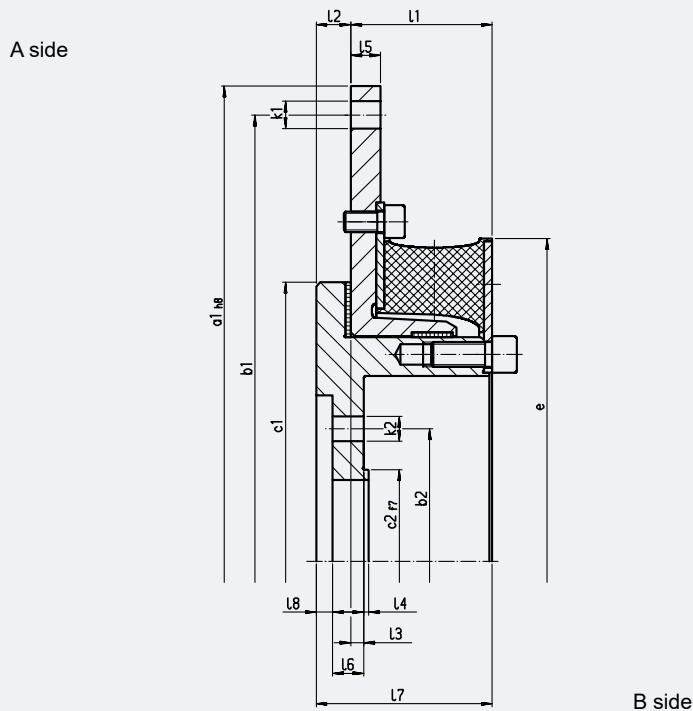

DD 880024 - 000

Metric, internal cardan shaft connection

Size		CS 51			CS 52	
SAE connection		18"			21"	
Cardan flange		225	250	285	250	285
Diameter mm	a ₁	571.5	571.5	571.5	673.1	673.1
	b ₁	542.9	542.9	542.9	641.4	641.4
	c ₁	440	440	440	440	440
	k ₁	12x17.5	12x17.5	12x17.5	12x17.5	12x17.5
	b ₂	196	218	245	218	245
	c ₂	140	140	175	140	175
	k ₂	8x16.1	8x18.1	8x20.1	8x18.1	8x20.1
	e	520	520	520	525	525
Lengths mm	l ₁	93	93	93	93	93
	l ₂	21	21	21	21	21
	l ₃	14.5	14.5	14.5	14.5	14.5
	l ₄	4.5	5.2	5.5	5.5	5.5
	l ₅	16.0	16.0	16.0	16.0	16.0
	l ₆	25.0	23.5	22.8	23.5	22.8
	l ₇	114	114	114	114	114
	l ₈	10.5	12.0	12.7	12.0	12.7
Mass moment of inertia kgm ²	J _{A side}	1.745	1.745	1.745	3.380	3.380
	J _{B side}	1.517	1.501	1.470	1.556	1.524
Mass kg		84.9	83.8	81.1	101.6	98.9

FLEXIBLE COUPLINGS

Stromag Periflex® CS Couplings

AFL/PVN Series

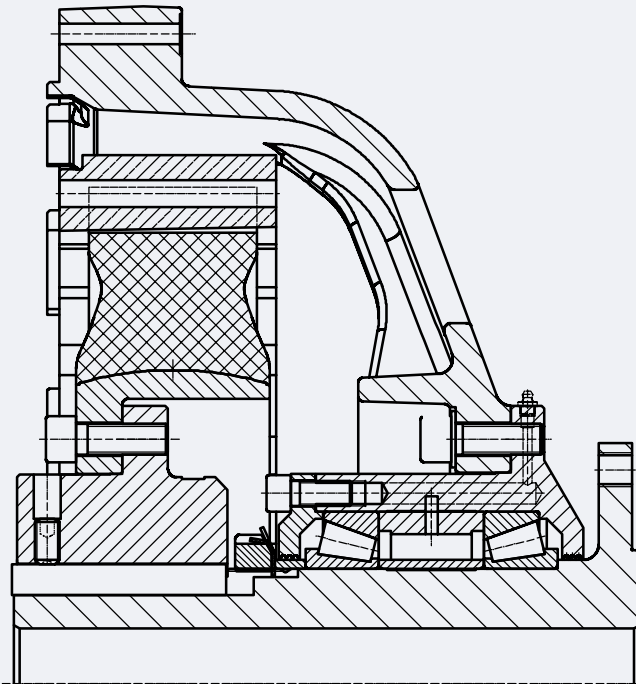

DD_881003 – 000

The flange bearing is a bell that is mounted to the diesel engine. An axially mountable, plug-in, highly flexible Stromag Periflex® disc tire arranged inside the bell transmits the torque from the flywheel to the cardan shaft.

The disc tyre has a linear spring characteristic and ensures the balanced torsional vibration behavior of the system, while the integrated bearing transmits the cardan shaft's reaction forces to the engine housing via the bell. This means that the crankshaft bearings are not exposed to the reaction forces. As a rule, the AFL can be use up to a deflection angle of 10°, larger deflection angles are possible on request, depending on the operating conditions.

The torque transferred by the series is determined by the Stromag Periflex® disc tire used. The torque range extends from 1000 Nm to 20.000 Nm.

The bell's connecting dimensions to the engine housing are based on SAE standard J617.

The connecting dimensions to the flywheel on the engine side primarily conform to SAE standard J620 or DIN 6281.

The cardan shaft side is available in a range of metric sizes, including for Spicer, Mechanics or cross-toothed connections on request.

The flange bearing's bell and the connection ring are manufactured from high-quality cast aluminum, while the other metal parts are steel.

The Stromag Periflex® disc tyre is manufactured from natural rubber (NR) or a synthetic rubber in various torsion spring stiffnesses. These allow an adjustment to drives that are susceptible to torsional vibrations.

FLEXIBLE COUPLINGS

Stromag Periflex® CS Couplings

Output table							
Coupling size	Tyre	Nominal torque	Maximum torque	Adm. alternating torque	Torsional stiffness	Relative damping	Adm. damping power
		T_{KN} Nm	T_{Kmax} (1) Nm	T_{KW} Nm	C_{Tdyn} 2) 4) Nm/rad	2) 4)	P_{KV60} 3) 5) W
PVN 350	35011	1000	3000	500	7660	0.80	260
	35031	1250	3000	625	11100	0.96	260
	35021	1250	3000	625	13990	1.00	260
	35041	1250	3000	625	16540	1.20	260
	35051	1250	3000	625	28860	1.30	260
PVN 358	35811	1600	4800	800	16700	0.80	260
	35831	2000	4800	1000	24200	0.96	260
	35821	2000	4800	1000	33200	1.00	260
	35841	2000	4800	1000	36060	1.20	260
	35851	2000	4800	1000	58500	1.30	260
PVN 430	43011	1600	4800	800	7800	0.80	494
	43031	2000	4800	1000	11300	0.96	494
	43021	2000	4800	1000	13900	1.00	494
	43041	2000	4800	1000	16840	1.20	494
	43051	2000	4800	1000	29380	1.30	494
PVN 433	43311	2500	7500	1250	18630	0.80	520
	43331	3150	7500	1550	27000	0.96	520
	43321	3150	7500	1550	34020	1.00	520
	43341	3150	7500	1550	40230	1.20	520
	43351	3150	7500	1550	70200	1.30	520
PVN 436	43611	4000	12000	2000	25400	0.80	572
	43631	5000	12000	2500	34600	0.96	572
	43621	5000	12000	2500	46600	1.00	572
	43641	5000	12000	2500	53640	1.20	572
	43651	5000	12000	2500	93600	1.30	572
PVN 439	43911	3200	10000	1600	36230	0.80	390
	43931	4000	10000	2000	52500	0.96	390
	43941	4000	10000	2000	76000	1.20	390
	43951	4000	10000	2000	13650	1.30	390
	PVN 544	54411	6300	19000	3150	62790	0.80
54431		8000	19000	4000	91000	0.96	622
54421		8000	19000	4000	114700	1.00	622
54441		8000	19000	4000	135600	1.20	622
54451		8000	19000	4000	226400	1.30	622
PVN 549	54911	8000	17000	4000	88320	0.80	650
	54931	9000	20000	4500	128000	0.96	650
	54921	9500	21000	4750	161300	1.00	650
	54941	11000	22000	5500	204700	1.20	650
	54951	12000	25000	6000	332800	1.30	650
PVN 666	66611	16000	48000	8000	111800	0.80	1100
	66631	20000	48000	10000	162000	0.96	1100
	66621	20000	48000	10000	205000	1.00	1100
	66641	20000	48000	10000	241400	1.20	1100
	66651	20000	48000	10000	428500	1.30	1100

1) The values listed in the tables refer to the characteristic values of the disc tyre.

2) For: $T_w = 0,2 \cdot T_{KN}$; $T = 0,8 \cdot T_{KN}$; $f = 10 \text{ Hz}$; $\vartheta = 30^\circ\text{C}$

3) When coupling temperatures are higher than 30°C , this value must be reduced by the temperature factor.

4) Material-related tolerances as high as $\pm 15\%$ are possible.

5) The P_{KV60} value describes the damping performance that can be absorbed over 60 minutes.

The damping power that can be absorbed permanently is $P_{KV\infty} = 0,5 \cdot P_{KV60}$.

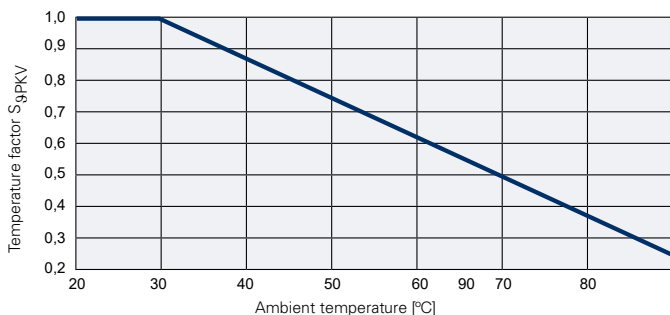

FLEXIBLE COUPLINGS

Stromag AFL/PVN Couplings

AFL/PVN dimension table

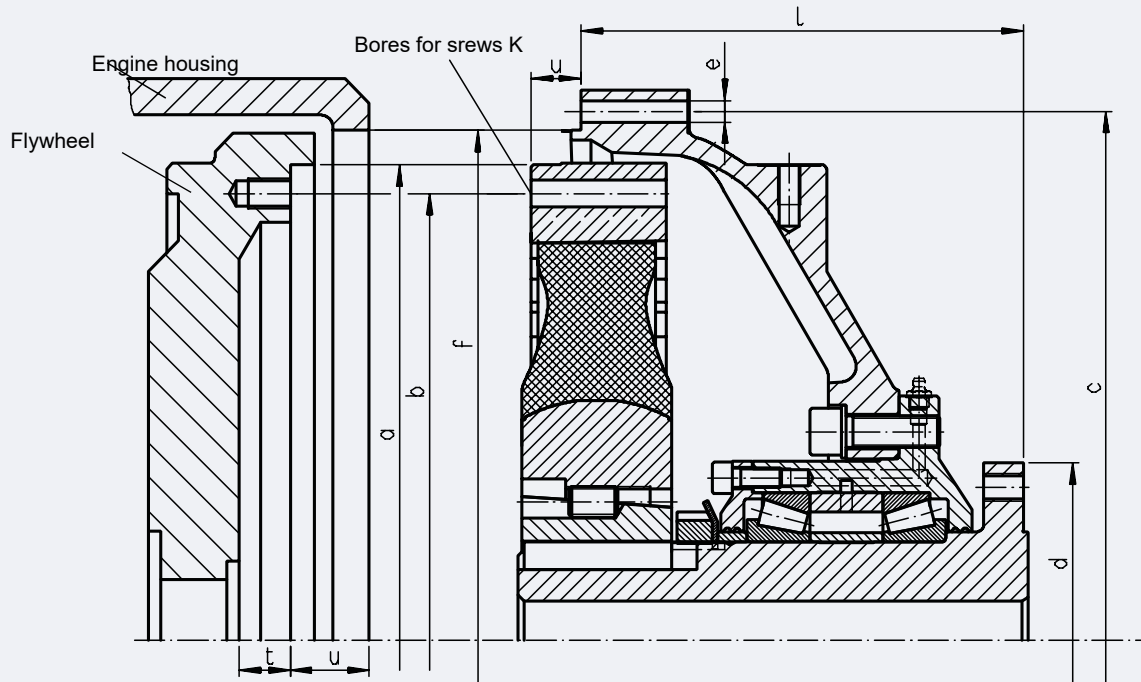

Housing	Flywheel	Coupling size	Adm. Speed n_{max} rpm	Diameter mm						Length mm			Cardan shaft
				a mm	b mm	f mm	c mm	e mm	k mm	u mm	t mm	l mm	
SAE J617	SAE J620												
2	11 1/2"	PVN 350 PVN 358	3000	352.4	333.4	447.7	466.7	12x 10.5	8x 11	39.6	29	175	120 150 165 180
		PVN 358	2000	352.4	333.4	511.2	530.2	12x 11	8x 11	39.6	29	225	150 165 180 225 250
1	14"	PVN 430 PVN 433 PVN 439 PVN 436	2000	466.7	438.2	511.2	530.2	12x 11	8x 13.5	25.4	29	225	
	0	14"	PVN 433 PVN 439 PVN 436	1600	466.7	438.2	647.7	679.5	16x 13.5	8x 13.5	25.4	29	
18"		PVN 544 PVN 549	1600	571.5	542.9	647.7	679.5	16x 13.5	12x 17.5	15.7	32	325	
00	18"	PVN 544 PVN 549	1600	571.5	542.9	787.4	850.9	16x 13.5	12x 17.5	0	32	395	250 285 315 350
	21"	PVN 666	1600	673.1	641.4	787.4	850.9	16x 13.5	12x 17.5	0	32	395	

FLEXIBLE COUPLINGS

Stromag IGE...FG Coupling

IGE...FG Series

Concept

The Stromag IGE...FG is a highly flexible rubber coupling with a progressive characteristic (see figure). It is ideal for the transmission of high torques with its particularly compact design and light weight.

The coupling's outer part can be connected directly to a diesel engine's flywheel or a similar part. The torque is transmitted to the hub and the cardan shaft via rubber elements arranged in a star pattern. The inner part of the coupling, consisting of the hub and support flange, is radially supported in the outer part of the coupling via the shaft and bushing and fixed in the axial direction using rings.

The radial and axial forces generated by the cardan shaft are absorbed by the coupling and transmitted to the main engine bearing.

The series extends across a nominal torque range from 4000 Nm to 25,000 Nm.

The Stromag IGE...FG is manufactured exclusively from metal or high-quality cast parts. They are manufactured from turned parts to ensure that they run smoothly and quietly.

The Stromag IGE...FG coupling is ideal for absorbing large impact torques due to the use of rubber elements with embedded extremely strong fabric. Large alternating torques are also permitted, as the damping heat is easily dissipated via the space between the individual elements.

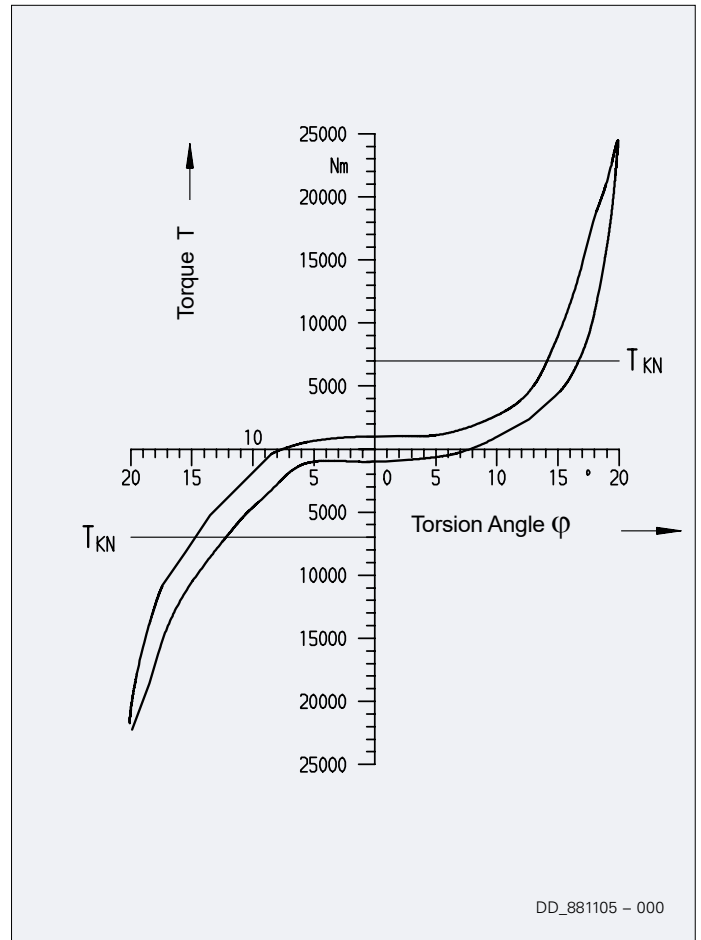

IGE...FG Series output table

IGE-Coupling size	Nominal torque	Maximum torque	Adm. alternating torque					Dyn. torsional stiffness					Adm. speed	Relative damping	Adm. damping power
	T_{KN} Nm	T_{Kmax} Nm	T_{Wzul} (at...% preload) [kNm/rad]					$C_{T dyn}$ (at...% preload) [kNm/rad] 1) 2)					n_{max} rpm	1) 2)	$P_{KV 60}$ [W] 3)
			10 %	25 %	50 %	75 %	100 %	10 %	25 %	50 %	75 %	100 %			
4	4000	12000	0.20	0.80	1.30	1.69	2.08	14.0	31.6	60.9	90.2	120	3900	1.0	940
8	8000	24000	0.40	1.60	2.60	3.38	4.16	36.2	73.2	135	196	258	2880	1.0	1200
12.5	12500	37500	0.63	2.50	4.06	5.28	6.50	59.9	118	214	310	406	2500	1.0	1380
25	25000	75000	1.25	5.00	8.13	10.56	13.00	139	274	497	721	945	2150	1.0	1800

1) For: $T_w = 0,2 \cdot T_{KN}$; $f = 10$ Hz

2) Material-related tolerances as high as $\pm 15\%$ are possible.

3) The $P_{KV 60}$ value describes the damping performance that can be absorbed over 60 minutes. Permanently absorbable damping performance $P_{KV \infty} = 0,5 \cdot P_{KV 60}$

FLEXIBLE COUPLINGS

Stromag IGE...FG Couplings

IGE...FG Series dimension table

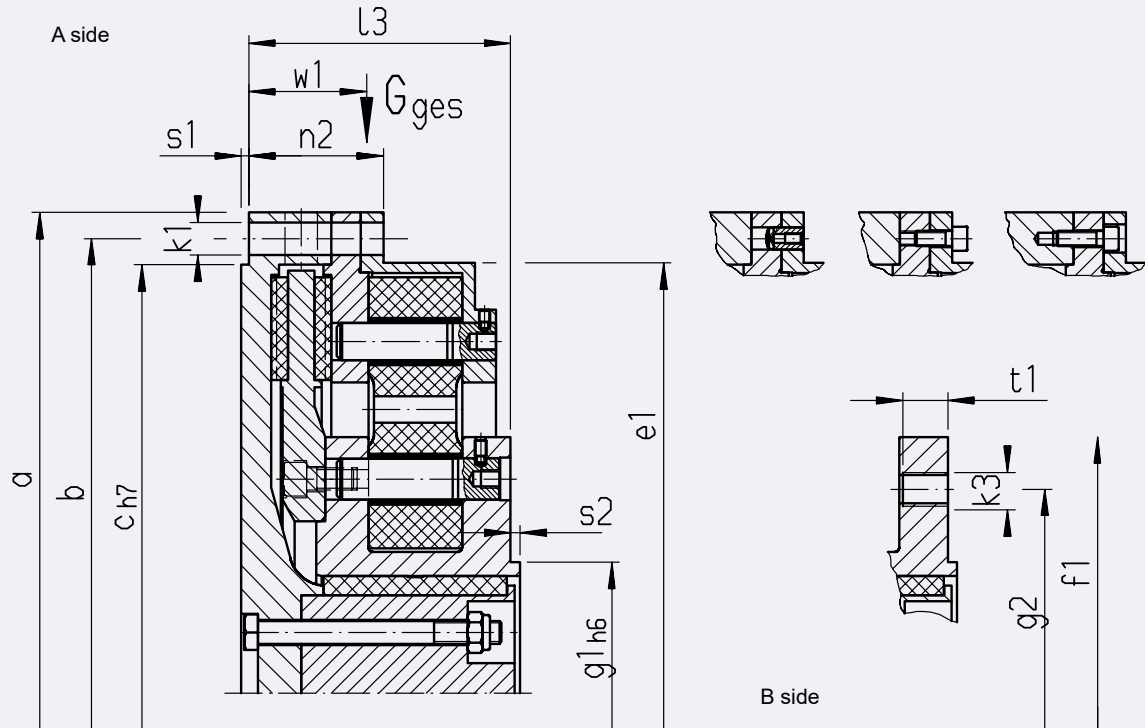

DD 881467 - 000

Coupling size		4	8	12.5	25
Cardan flange		225	250	285	315
Diameter mm	a	380	514	593	690
	b	354	486	561	650
	c	328	458	529	610
	e_1	329	460	530	612
	f_1	225	274	330	400
	g_1	140	140	175	175
	g_2	196	218	245	280
	k_1	16x13.5	16x17.5	16x17.5	16x22
	k_3	8xM16	8xM18	8xM20	8xM22
Length mm	l_3	126	140	165	190
	n_2	62.5	72	78	90
	s_1	3	4	5	5
	s_2	4	5	6	6
	t_1	22	24	25	34
	w_1	48	52	63	73
	Mass kg	G_{ges}	64	129	190
Mass moment of inertia kgm^2	J_i	0.23	0.83	1.60	3.30
	J_a	0.83	3.07	5.98	13.40

FLEXIBLE COUPLINGS

Characteristics

T_{KN}	
The coupling's nominal torque can be continuously transmitted over the whole permitted speed range. It must not be exceeded by the system's nominal torque T_N .	$T_{KN} \geq T_N$
T_{Kmax1}	
The coupling's maximum torque T_{Kmax1} can be endured as a peak load and may not be exceeded by normal, non-stationary system peak torques T_{max1} . A system's normal, non-stationary modes are unavoidable and occur repeatedly (e.g.: starting/stopping processes, resonance pass, switching processes, acceleration processes, etc.).	$T_{Kmax1} \geq T_{max1}$
T_{Kmax2}	
The coupling's maximum torque T_{Kmax2} can be endured as a rarely occurring peak load and may not be exceeded by normal, non-stationary system peak torques T_{max2} . Anomalous, non-stationary system peak torques are avoidable and are not part of the planned operating scheme (e.g.: emergency stop, sync failure, short circuit, etc.). A coupling overload due to anomalous, non-stationary system peak torques T_{max2} shortens the system's service life and is tolerated in individual cases.	$T_{Kmax2} \geq T_{max2}$
T_{Kw}	
The admissible permanent alternating torque indicates the amplitude of the admissible permanent periodic torque fluctuation. This torque may be superimposed on a base load of T_{KN} . In this process, the max damping power P_{KV} must also be checked.	

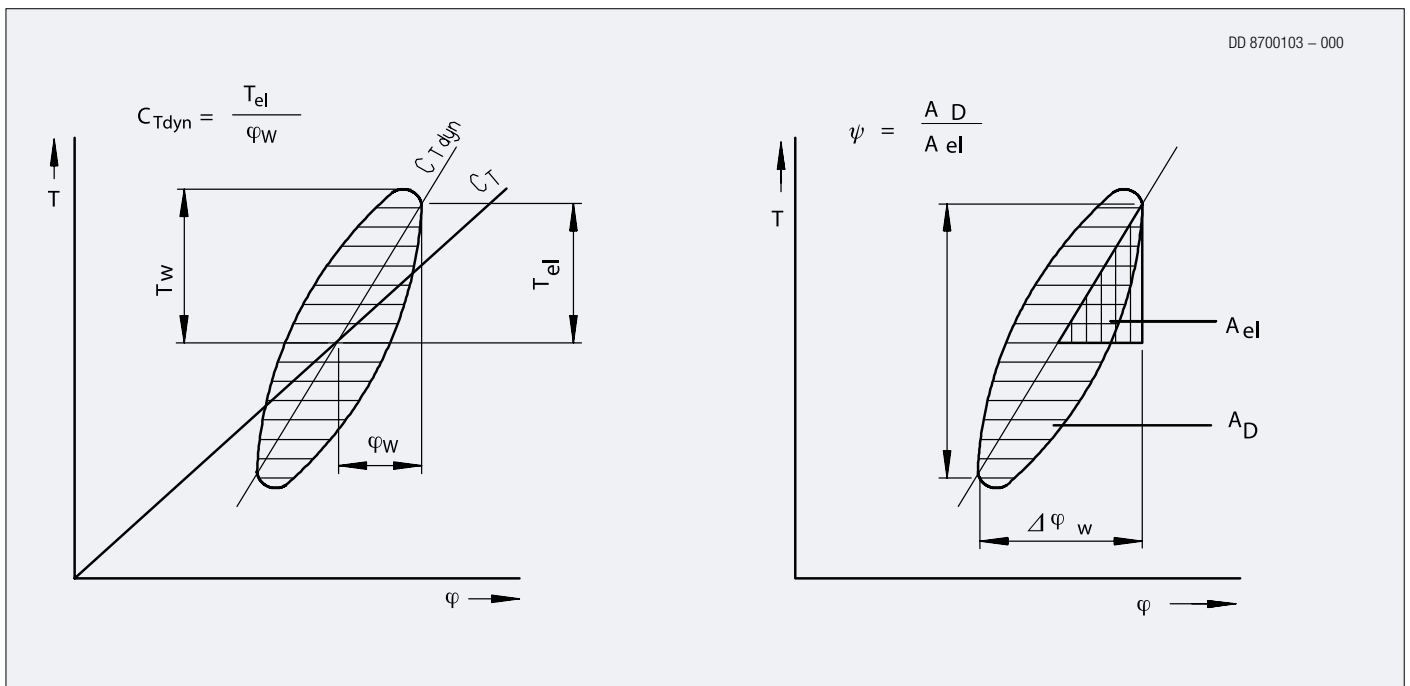

C_{Tdyn}

The dynamic torsional stiffness indicates the ratio of torque amplitude to torsion angle amplitude during an oscillation.

The torque amplitude is superimposed on an initial load (coupling torque).

For couplings with a linear characteristic (Stromag Periflex® CS and AFL), the C_{Tdyn} value over the coupling torque is constant. However, it changes depending on the amplitude, the frequency and the temperature of the flexible element.

C_{Tdyn} data relate to a coupling torque of $0,8 \cdot T_{KN}$, an alternating torque of $0,2 \cdot T_{KN}$ and a frequency of 10 Hz for a coupling at operating temperature with a surface temperature of about 30°C.

Stromag IGE coupling has a progressive characteristic. I.e. the C_{Tdyn} value also changes depending on the coupling torque.

$$C_{Tdyn} = \frac{T_{el}}{\varphi_w}$$

Ψ

The relative damping is a measure of the ability of the coupling to convert part of the vibration energy into heat.

The damping can be determined using the damping loop (hysteresis loop).

A_{el} surface represents the flexible strain energy W_{el} during a load.

The A_D surface is a measure for the damping work W_D during a vibration cycle.

The Y data relate to a coupling torque of $0,8 \cdot T_{KN}$, an alternating torque of $0,2 \cdot T_{KN}$ and a frequency of 10 Hz for a coupling at operating temperature with a surface temperature of about 30°C.

$$\Psi = \frac{W_D}{W_{el}} = \frac{A_D}{A_{el}}$$

P_{kv}

The permitted damping power indicates how much damping (heat) the coupling can permanently absorb and dissipate.

The sum of the damping performance from every vibration order (i.e. P_{vi}) must be less than the coupling's damping performance.

$$P_{vi} = \frac{\pi}{\sqrt{\left(\frac{2\pi}{\Psi}\right)^2 + 1}} \cdot \frac{T_{wi}^2 \cdot f_i}{C_{Tdyn}}$$

$$P_{KV} \geq \sum P_{vi}$$

P_{KV60} value describes the damping performance that can be absorbed over an hour.

P_{KV60} value needs to be multiplied by a factor of 0.5 to determine the damping performance that can be permanently absorbed ($P_{KV\infty}$).

FLEXIBLE COUPLINGS

Coupling Design, question sheet

Main engine		
Engine type (electric, combustion engine, etc.)		
Engine make (manufacturer, type)		
Engine installation (rigid, flexible)		
Engine housing, SAE		
Flywheel centering diameter		(mm)
Nominal power		(kW)
Nominal speed		(rpm)
Speed range		(rpm)
Nominal torque		(Nm)
Maximum torque (breakdown torque)		(Nm)
Mass moment of inertia		(kgm ²)
Number of start-ups or reversals every hour		
Cardan shaft		
Deflection angle		(°)
Type of cardan shaft deflection ("z" or "w")		
Cardan shaft type (manufacturer, size)		
Length of the cardan shaft		(mm)
Slide coated splines? Yes/No		
Mass moment of inertia		(kgm ²)
Gear unit		
Gear ratio		
Mass moment of inertia		(kgm ²)
Main engine		
Type (generator, ventilator, compressor, fixed or variable pitch propeller)		
Main or auxiliary drive		
Design type (stand-alone or flange-mounted)		
Mass moment of inertia		(kgm ²)
Coupling		
Location in the drive train (enclose schematic diagram)		
Ambient temperature		(°C, °K)
Classification society		
Ship type		
Ice class		



Stop seeing individual parts. Start seeing unlimited possibilities.

Regardless of your objectives or the challenges with your application, Powertrain Solutions can help you achieve your unique goals. No matter what your application looks like, it relies on many components, all working together. But not all components are made to work together reliably and efficiently. Powertrain Solutions has the insight, experience and expertise to engineer your collection of components into a fully optimized system — giving you solutions that boost efficiency, improve reliability and performance, lower costs and simplify ordering and logistics.

WHERE OTHERS SEE PARTS, WE SEE A SYSTEM



Bearings



Belt & Chain
Drives



Clutches &
Brakes



Conveying



Disc & Gear
Couplings



Motors



Speed Reducers
& Gearboxes



Monitoring &
Diagnostics

It's time to see the bigger picture.

Get started at RegalRexnord.com/Powertrain



Regal Rexnord

[regalrexnord.com](https://www.regalrexnord.com)

Stromag GmbH

Hansatraße 120

59425 Unna - Germany

+49 2303 102 - 0

[Stromag.com](https://www.stromag.com)

The proper selection and application of products and components, including assuring that the product is safe for its intended use, are the responsibility of the customer. To view our Application Considerations, please visit <https://www.regalrexnord.com/Application-Considerations>.

To view our Standard Terms and Conditions of Sale, please visit <https://www.regalrexnord.com/Terms-and-Conditions-of-Sale>.

"Regal Rexnord" is not indicative of legal entity. Refer to product purchase documentation for the applicable legal entity.

Regal Rexnord and Stromag are trademarks of Regal Rexnord Corporation or one of its affiliated companies.

©2024 Regal Rexnord Corporation, All Rights Reserved.
MCC-P-8468-SG A4-EN 08/24

