



PERIFLEX® VN
DISC COUPLINGS





DECADES OF EXPERIENCE

Across Industries and Applications



Founded in 1932, Stromag™ has grown to become a globally recognized leader in the development and manufacture of innovative power transmission components for industrial drivetrain applications.

Stromag engineers utilize the latest design technologies and materials to provide creative, energy-efficient solutions that meet their customer's most challenging requirements.

Stromag's extensive product range includes flexible couplings, disc brakes, limit switches, an array of hydraulically, pneumatically, and electrically actuated brakes, and a complete line of electric, hydraulic and pneumatic clutches.

Stromag engineered solutions improve drivetrain performance in a variety of key markets including energy, off-highway, metals, marine, transportation, printing, textiles, and material handling on applications such as wind turbines, conveyor systems, rolling mills, agriculture and construction machinery, municipal vehicles, forklifts, cranes, presses, deck winches, diesel engines, gensets and stage machinery.

VISIT US ON THE WEB AT **STROMAG.COM**



CONTENT

PERIFLEX® VN DISC COUPLINGS: I

COUPLING AT A GLANCE	4
Product range	
Benefits include	
Applications areas	
Fail-safe device	
Classifications	
Torque range	
Instruction for the designer	
Use in potentially explosive environments	
The torsional vibration analysis	
Stromag Periflex® VN NR Series output table	11
Stromag Periflex® VP NR Series output table	13
SERIES G	
Stromag Periflex® VN ... Series G	14
Stromag Periflex® VP ... Series G	16
SERIES R	
Stromag Periflex® VN ... Series R	17
Stromag Periflex® VP ... Series R	19
SERIES S	
Stromag Periflex® VN ... Series S	20
SERIES W	
Stromag Periflex® VN ... Series W	22
Stromag Periflex® VP ... Series W	24
Characteristic	25
Coupling Design, question sheet	28
Use in potentially explosive environments, question sheet	29

FLEXIBLE COUPLINGS

AT A GLANCE

PERIFLEX® DISC COUPLING PRODUCT RANGE

SERIES G

Nominal torque range: 160 – 63,000 Nm



PERIFLEX® VN ... SERIES G

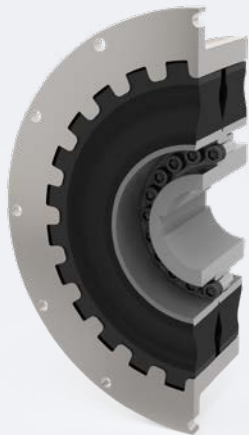

PERIFLEX® VP ... SERIES G

SERIES R - Radial installations

Nominal torque range: 160 – 63,000 Nm



PERIFLEX® VN ... SERIES R



PERIFLEX® VP ... SERIES R

SERIES S

Nominal torque range: 160 – 8000 Nm



PERIFLEX® VN ... SERIES S

SERIES W - Shaft Coupling

Nominal torque range: 160 – 63,000 Nm



PERIFLEX® VN ... SERIES W



PERIFLEX® VP ... SERIES W

FLEXIBLE COUPLINGS

AT A GLANCE

STROMAG PERIFLEX® VN DISC COUPLINGS

BENEFITS INCLUDE

- Periflex®VN Couplings are highly flexible elastomer couplings with linear spring characteristics ideal for diesel engine drives.
- Allow fast and simple connection of a flange, especially a flywheel, to a shaft. Some designs also allow the connection of two shafts.
- Periflex®VN Couplings are couplings that features an axial plug-in connection for easy installation and removal, for both the entire coupling and the flexible element.
- Come with each with a range of elastomer qualities and torsional spring stiffnesses. These allow precise configurations for drives susceptible to torsional vibrations.
- Cover the torque range 160 – 63,000 Nm. The external companion dimensions conform as standard to the flywheel connections under the SAE standard J620.
The larger couplings are basically designed with metric flywheel connections.
- At the fully intermeshing teeth on the connection ring, the disc tire can be displaced along its axis by several millimetres when no torque is applied.
- On request, high temperature mixture available for stationary systems up to 8000 Nm.

APPLICATIONS AREAS



- Stromag Periflex® VN couplings are designed for use on piston engines. The connection ring can be bolted directly to the flywheel of an engine or compressor.
- Its axial plug-in design presents particular advantages e.g. for installations under bell covers.
- Other application fields are electrical assemblies, compressors, construction machinery, engine and shipbuilding and general machinery.

FAIL-SAFE DEVICE

The Stromag Periflex® VN coupling is available with a fail-safe device. A rupture in the flexible element causes claws to intermesh, forming a torsionally rigid, backlash connection between the drive and output sides. Temporary emergency operation is possible with limited torque.

The permissible torques and speeds must be calculated separately on the basis of torsional vibrations transferred via a torsionally rigid structure.



FLEXIBLE COUPLINGS

AT A GLANCE

CLASSIFICATIONS



For survey of the coupling by a classification society, the regulations of the society have to be adhered to. The coupling characteristics may differ from the definitions given in this catalogue. Accordingly prepared data sheets are available on request. A number of classification societies prescribe fail-safe devices on ships main drives.

TORQUE RANGE

- 160 up to 63,000 Nm

INSTRUCTION FOR THE DESIGNER

The Stromag Periflex® VN coupling hubs are made of steel or ductile cast iron. The connection ring is made of aluminium. The disc tires consist of a steel or ductile cast iron angular ring with a volume of vulcanized elastomer. The variants of natural rubber (NR) can be used at temperatures of -50°C to +80°C. The high temperature Coupling variant can be used from -30°C up to 120°C.

Damping work may cause the flexible element to reach temperatures higher than ambient. This must be considered when the coupling is to be fitted with a guard or cowl, and adequate ventilation and heat dissipation must be provided.

The Stromag Periflex® VN coupling can be delivered with EN 10204 acceptance as defined in the classification societies rules.

The coupling complies with the requirements under API 671 with consideration to our list of deviations TM 800.0010.

This list of deviations is available from the Stromag GmbH departments.

USE IN POTENCIALLY EXPLOSIVE ENVIROMENTS



The coupling conforms to the requirements under Directive 2014/34/EU and can be used as follows:

- Zone 1** (gas, Category 2G) in Groups IIA, IIB, and IIC, T4
- Zone 2** (gas, Category 3G) in Groups IIA, IIB, and IIC, T4
- Zone 22** (dust, Category 3D) for dusts with a minimum ignition energy > 3 mJ, T 125 °C

The Stromag Periflex® VN coupling compliance with the requirements for each of these zones / categories is documented in the form of the following codes on our products:

Use in gas atmospheres:

CE II 2G Ex h IIC (T4) Gb

Use in dust atmospheres:

CE II 3D Ex h IICT120°C Dc

Use in potentially explosive environments must be based on the request form annexed to this catalogue.

THE TORSIONAL VIBRATION ANALYSIS



Stromag's Know-how in Torsional Vibration Analysis (TVA) constitutes the core of each coupling design. It provides a comprehensive analysis of loads in the crankshaft, coupling and driven side to ensure that no critical speeds occur during operation.

Unevenly rotating systems can severely degrade product quality and cause great harm to the powertrain. On a daily basis, the TVA experts at Stromag work on the challenge of detecting such deviations by measuring them and protecting the entire powertrain with ideal product selection. Stromag is capable of calculating stationary and transient operating conditions considering the stiffness and damping of the elastomers.

FLEXIBLE COUPLINGS

Stromag Periflex® VN Disc Coupling



FLEXIBLE COUPLINGS

Stromag Periflex® VN Disc Coupling

Stromag Periflex® VN NR Series output table											
Coupling size	Type	Nominal torque	Max torque	Adm. alternating torque	Adm. radial displacement	Radial stiffness	Torsional stiffness	Relative damping	Adm. damping power	SAE connection	Max Speed
		T _{kn} Nm	Tk _{max} 1) Nm	T _{KW} Nm	ΔK _r mm	C _{r dyn} 4) N/mm	C _{T dyn} 2) 4) Nm/rad	2) 4)	P _{KV 60} 3) 5) W		n _{max} rpm
Periflex® VN 183	VN 18311	160	480	80	0,4	375	1150	0,80	104	6 ½" 7 ½" 8"	5000 4400 4000
	VN 18331	200	480	100		600	1510	0,96	104		
	VN 18321	200	480	100		730	1900	1,00	104		
	VN 18341	200	480	100		900	2240	1,20	104		
	VN 18351	200	480	100		1500	3910	1,30	104		
Periflex® VN 230	VN 23011	250	750	125	0,5	400	1510	0,80	156	8" 10"	4000 3600
	VN 23031	315	750	155		650	2000	0,96	156		
	VN 23021	315	750	155		800	2760	1,00	156		
	VN 23041	315	750	155		950	3260	1,20	156		
	VN 23051	315	750	155		1600	5690	1,30	156		
Periflex® VN 280	VN 28011	400	1200	200	0,6	350	2280	0,80	221	10" 11 ½"	3600 3600
	VN 28031	500	1200	250		750	3300	0,96	221		
	VN 28021	500	1200	250		900	4160	1,00	221		
	VN 28041	500	1200	250		1060	4920	1,20	221		
	VN 28051	500	1200	250		1750	8580	1,30	221		
Periflex® VN 283	VN 28311	630	1900	315	0,6	500	3760	0,80	234	10" 11 ½"	3600 3600
	VN 28331	800	1900	400		1050	5450	0,96	234		
	VN 28321	800	1900	400		1270	7200	1,00	234		
	VN 28341	800	1900	400		1500	8120	1,20	234		
	VN 28351	800	1900	400		2450	14170	1,30	234		
Periflex® VN 350	VN 35011	1000	3000	500	0,7	750	7660	0,80	260	11 ½" 14"	3600 3000
	VN 35031	1250	3000	625		1200	11100	0,96	260		
	VN 35021	1250	3000	625		1500	13990	1,00	260		
	VN 35041	1250	3000	625		1800	16540	1,20	260		
	VN 35051	1250	3000	625		3000	28860	1,30	260		
Periflex® VN 358	VN 35811	1600	4800	800	0,5	3400	16700	0,80	260	11 ½" 14"	3600 3000
	VN 35831	2000	4800	1000		5100	24200	0,96	260		
	VN 35821	2000	4800	1000		6300	33200	1,00	260		
	VN 35841	2000	4800	1000		7650	36060	1,20	260		
	VN 35851	2000	4800	1000		12600	58500	1,30	260		
Periflex® VN 430	VN 43011	1600	4800	800	0,9	660	7800	0,80	494	14" 18"	3000 2400
	VN 43031	2000	4800	1000		1400	11300	0,96	494		
	VN 43021	2000	4800	1000		1700	13900	1,00	494		
	VN 43041	2000	4800	1000		2000	16840	1,20	494		
	VN 43051	2000	4800	1000		3300	29380	1,30	494		

FLEXIBLE COUPLINGS

Stromag Periflex® VN Disc Coupling

Stromag Periflex® VN NR Series output table											
Coupling size	Type	Nominal torque	Max torque	Adm. alternating torque	Adm. radial displacement	Radial stiffness	Torsional stiffness	Relative damping	Adm. damping power	SAE connection	Max Speed
		T _{KN} Nm	T _{Kmax} ¹⁾ Nm	T _{kW} Nm	ΔK _r mm	C _{r dyn} ⁴⁾ N/mm	C _{T dyn} ^{2) 4)} Nm/rad	ψ ^{2) 4)}	P _{kV 60} ^{3) 5)} W		n _{max} rpm
Periflex® VN 433	VN 43311	2500	7500	1250	0,8	1400	18630	0,80	520	14" 18	3000 2400
	VN 43331	3150	7500	1550		2300	27000	0,96	520		
	VN 43321	3150	7500	1550		2870	34020	1,00	520		
	VN 43341	3150	7500	1550		3450	40230	1,20	520		
	VN 43351	3150	7500	1550		5700	70200	1,30	520		
Periflex® VN 436	VN 43611	4000	12000	2000	0,7	2300	25400	0,80	572	14" 16" 18"	3000 2600 2400
	VN 43631	5000	12000	2500		3800	34600	0,96	572		
	VN 43621	5000	12000	2500		4750	46600	1,00	572		
	VN 43641	5000	12000	2500		5700	53640	1,20	572		
	VN 43651	5000	12000	2500		9400	93600	1,30	572		
Periflex® VN 439	VN 43911	3200	10000	1600	0,7	1750	36230	0,80	390	14" 16" 18"	3000 2600 2400
	VN 43931	4000	10000	2000		2600	52500	0,96	390		
	VN 43941	4000	10000	2000		3900	76000	1,20	390		
	VN 43951	4000	10000	2000		6500	136500	1,30	390		
Periflex® VN 544	VN 54411	6300	19000	3150	0,8	3100	62790	0,80	622	18" 21"	2400 1800
	VN 54431	8000	19000	4000		5100	91000	0,96	622		
	VN 54421	8000	19000	4000		7600	114700	1,00	622		
	VN 54441	8000	19000	4000		11400	135600	1,20	622		
	VN 54451	8000	19000	4000		17100	226400	1,30	622		
Periflex® VN 549	VN 54911	8000	17000	4000	0,8	6000	88320	0,80	650	18" 21"	2400 1800
	VN 54931	9000	20000	4500		9000	128000	0,96	650		
	VN 54921	9500	21000	4750		11250	161300	1,00	650		
	VN 54941	11000	22000	5500		13500	204700	1,20	650		
	VN 54951	12000	25000	6000		22000	332800	1,30	650		
Periflex® VN 666	VN 66611	16000	48000	8000	0,8	6100	111800	0,80	1100	21" 24"	1800 1500
	VN 66631	20000	48000	10000		10200	162000	0,96	1100		
	VN 66621	20000	48000	10000		15200	205000	1,00	1100		
	VN 66641	20000	48000	10000		22800	241400	1,20	1100		
	VN 66651	20000	48000	10000		34200	428500	1,30	1100		
Periflex® VN 726	VN 72611	28500	68500	14250	0,8	7080	225000	0,80	1300	24"	1500
	VN 72631	31500	75500	15750		11800	300000	0,96	1300		
	VN 72621	31500	75500	15750		17630	370000	1,00	1300		
	VN 72641	31500	75500	15750		26450	530000	1,20	1300		
	VN 72651	31500	75500	15750		39670	950000	1,30	1300		

FLEXIBLE COUPLINGS

Stromag Periflex® VN Disc Coupling

Stromag Periflex® VP NR Series output table											
Coupling size	Tire	Nominal torque	Max torque	Adm. alternating torque	Adm. radial displacement	Radial stiffness	Torsional stiffness	Relative damping	Adm. damping power	SAE connection	Max. Speed
		T _{KN} Nm	T _{Kmax} 1) Nm	T _{KW} Nm	ΔK _r mm	C _{r dyn} 4) N/mm	C _{T dyn} 2) 4) Nm/rad	ψ 2) 4)	P _{KV60} 3) 5) W		n _{max} rpm
Periflex® VP 433	VN 43311	5000	15000	2500	0,8	2800	37260	0,80	1040	18"	2400
	VN 43331	6300	15000	3100		4600	54000	0,96	1040		
	VN 43321	6300	15000	3100		5740	68040	1,00	1040		
	VN 43341	6300	15000	3100		6900	80460	1,20	1040		
	VN 43351	6300	15000	3100		11400	140400	1,30	1040		
Periflex® VP 436	VN 43611	8000	24000	4000	0,7	4600	50800	0,80	1140	18"	2400
	VN 43631	10000	24000	5000		7600	69200	0,96	1140		
	VN 43621	10000	24000	5000		9500	93200	1,00	1140		
	VN 43641	10000	24000	5000		11400	107300	1,20	1140		
	VN 43651	10000	24000	5000		18800	187200	1,30	1140		
Periflex® VP 439	VN 43911	6400	20000	3200	0,7	3500	72460	0,80	780	18"	2400
	VN 43931	8000	20000	4000		5200	105000	0,96	780		
	VN 43941	8000	20000	4000		7800	152000	1,20	780		
	VN 43951	8000	20000	4000		13000	273000	1,30	780		
Periflex® VP 544	VN 54411	12600	38000	6300	0,8	6200	125600	0,80	1240	21"	1800
	VN 54431	16000	38000	8000		10200	182000	0,96	1240		
	VN 54421	16000	38000	8000		15200	229300	1,00	1240		
	VN 54441	16000	38000	8000		22800	271200	1,20	1240		
	VN 54451	16000	38000	8000		34200	452800	1,30	1240		
Periflex® VP 549	VN 54911	16000	34000	8000	0,8	12000	176600	0,80	1300	21"	1800
	VN 54931	18000	40000	9000		18000	256000	0,96	1300		
	VN 54921	19000	42000	9500		22500	322600	1,00	1300		
	VN 54941	22000	44000	11000		27000	400400	1,20	1300		
	VN 54951	24000	50000	12000		44000	665600	1,30	1300		
Periflex® VP 666	VN 66611	32000	96000	16000	0,8	12200	223600	0,80	2200	24"	1500
	VN 66631	40000	96000	20000		20400	324000	0,96	2200		
	VN 66621	40000	96000	20000		30400	410000	1,00	2200		
	VN 66641	40000	96000	20000		45600	482800	1,20	2200		
	VN 66651	40000	96000	20000		68400	857000	1,30	2200		
Periflex® VP 726	VN 72611	57000	137000	28500	0,8	14160	450000	0,80	2600	metric	1500
	VN 72631	63000	151000	31500		23600	600000	0,96	2600		
	VN 72621	63000	151000	31500		35260	740000	1,00	2600		
	VN 72641	63000	151000	31500		52900	1060000	1,20	2600		
	VN 72651	63000	151000	31500		79340	1900000	1,30	2600		

- 1) The values listed in the tables refer to the disc tire characteristics.
- 2) For: $T_W = 0,2 \cdot T_{KN}$; $T = 0,8 \cdot T_{KN}$; $f = 10 \text{ Hz}$; $\vartheta = 30^\circ\text{C}$
- 3) This value must be reduced by the temperature factor when the coupling temperatures are higher than 30°C .
- 4) Tolerances on the materials may be as high as $\pm 15\%$.
- 5) P_{KV60} value represents the damping power that can be absorbed over a period of 60 minutes.
The damping power that can be absorbed permanently is $P_{KV\infty} = 0,5 \cdot P_{KV60}$.

Temperature factor S_{9PKV}						
Ambient temperature [°C]	-30 °C up to 30°C	40	50	60	70	80
Temperature factor S_{9PKV} [-]	1,0	0,875	0,750	0,625	0,500	0,375

FLEXIBLE COUPLINGS

Stromag Periflex® VN Disc Coupling

Stromag Periflex® VN...G Series

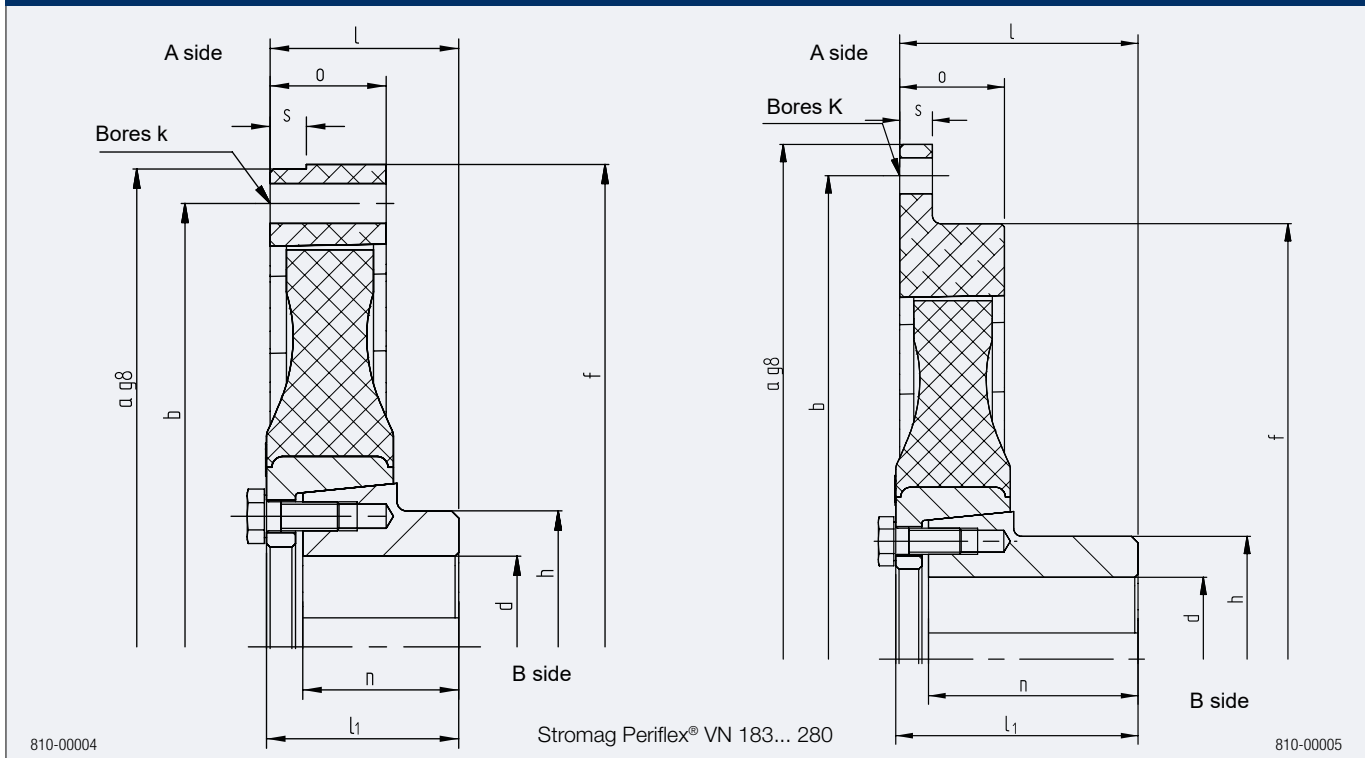

Size	PVN 183		P VN 230		P VN 280		PVN 283		P VN 350		P VN 358		P VN 430			
Tire	VN 18311 VN 18331 VN 18321 VN 18341 VN 18351		VN 23011 VN 23031 VN 23021 VN 23041 VN 23051		VN 28011 VN 28031 VN 28021 VN 28041 VN 28051		VN 28311 VN 28331 VN 28321 VN 28341 VN 28351		VN 35011 VN 35031 VN 35021 VN 35041 VN 35051		VN 35811 VN 35831 VN 35821 VN 35841 VN 35851		VN 43011 VN 43031 VN 43021 VN 43041 VN 43051			
SAE Connection	6½"	7½"	8"	8"	10"	10"	11½"	10"	11½"	11½"	14"	11½"	14"	14"	18"	
Diameter mm	a	215.9	241.3	263.5	263.5	314.4	314.4	352.4	314.4	352.4	352.4	466.7	352.4	466.7	466.7	571.5
	b	200	222.3	244.5	244.5	295.3	295.3	333.4	295.3	333.4	333.4	438.2	333.4	438.2	438.2	542.9
	d _{max}	45	45	45	50	50	60	60	70	70	85	85	95	95	95	95
	f	218	218	218	266	266	316	316	316	316	355	355	355	355	468	468
h	70	70	70	75	75	90	90	98	98	119	119	132	132	132	132	
Bore k mm	6x9	8x9	6x11	6x11	8x11	8x11	8x11	8x11	8x11	8x11	8x13.5	8x11	8x13.5	8x13.5	6x17.5	
Lengths mm	l ¹⁾	40	40	52	52	72.8	72.8	106.6	72.8	106.6	106.6	92.4	106.6	92.4	92.4	82.7
	l ₁	45	45	57	53	74	76	110	_*	_*	_*	_*	_*	_*	_*	_*
	n	35	35	47	43	64	65	99	82	105	105	105	105	105	105	105
	o	25	25	25	32	32	40	40	40	40	55	55	55	55	54	80
	s	8	8	8	10	10	10	10	10	10	10	12	10	12	15	20
Mass moment of inertia kg m ²	J _{A side}	0.0076	0.0103	0.0134	0.0203	0.0329	0.0429	0.0574	0.0485	0.0625	0.0818	0.2033	0.0842	0.1915	0.2945	0.7205
	J _{B side} ²⁾	0.0036	0.0036	0.0038	0.0079	0.0083	0.0186	0.0199	0.0235	0.0245	0.0547	0.0546	0.0855	0.0849	0.1265	0.1255
Mass kg 2)	2.7	2.59	3.3	4.2	5.2	7.0	8.5	7.6	8.9	13.4	15.7	15.8	17.7	19.8	26.4	

*) Dim l₁ not applicable on this version
 1) Dim. l can be modified by moving the connection ring within specified tolerances
 2) at max. bore d

FLEXIBLE COUPLINGS

Stromag Periflex® VN Disc Coupling

Stromag Periflex® VN...G Series

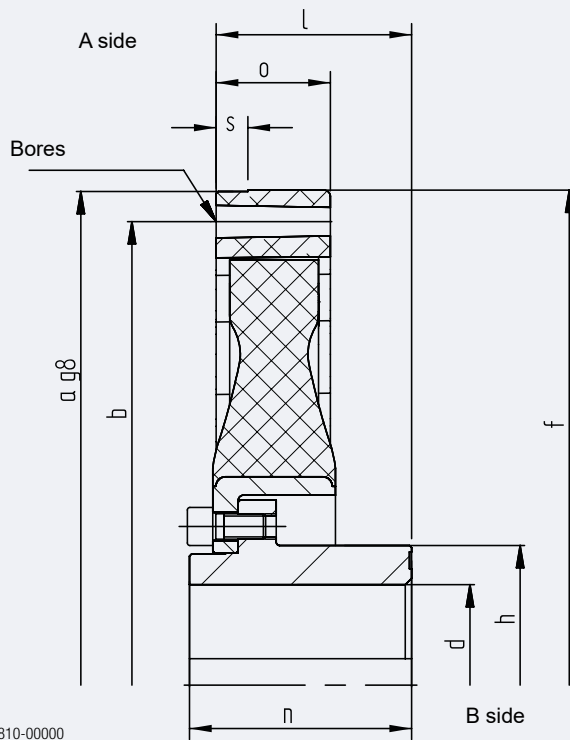

810-00000

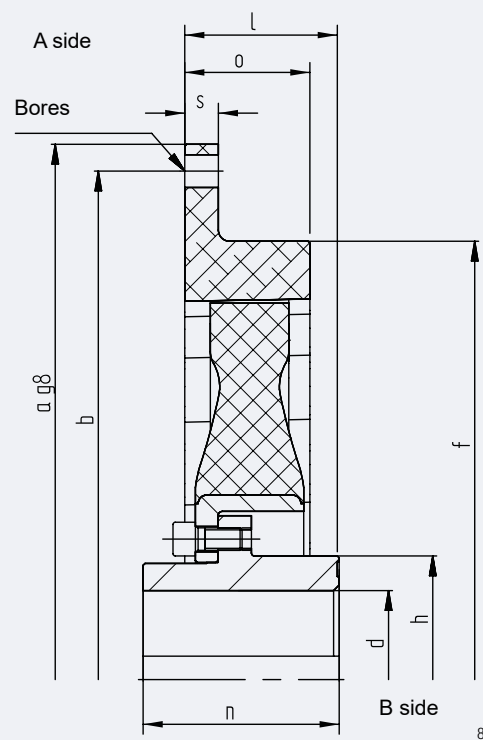

810-00001

Size	P VN 433		P VN 436			P VN 439			P VN 544		P VN 549		P VN 666		P VN 726
Tire	VN 43311 VN 43331 VN 43321 VN 43341 VN 43351		VN 43611 VN 43631 VN 43621 VN 43641 VN 43651			VN 43911 VN 43931 - VN 43941 VN 43951			VN 54411 VN 54431 VN 54421 VN 54441 VN 54451		VN 54911 VN 54931 VN 54921 VN 54941 VN 54951		VN 66611 VN 66631 VN 66621 VN 66641 VN 66651		VN 72611 VN 72631 VN 72621 VN 72641 VN 72651
SAE Connection	14"	18"	14"	16"	18"	14"	16"	18"	18"	21"	18"	21"	21"	24"	24"
Diameter mm	a	466.7	571.5	466.7	517.5	571.5	466.7	517.5	571.5	673.1	571.5	673.1	673.1	733.4	733.4
	b	438.2	542.9	438.2	489	542.9	438.2	489	542.9	641.4	542.9	641.4	641.4	692.2	692.2
	d _{max}	110	110	120	120	120	130	130	130	160	180	180	190	190	250
	f	468	468	468	468	468	-	455	455	572	572	572	572	692	692
	h	154	154	168	168	168	185	185	185	225	225	300	300	270	270
Bore k mm	8x13.5	6x17.5	8x13.5	8x13.5	6x17.5	8x13.5	8x13.5	6x17.5	12x17.5	12x17.5	12x17.5	12x17.5	12x17.5	12x20	24x20
Lengths mm	l ¹⁾	92.4	82.7	92.4	130.7	130.7	92.4	130.7	130.7	130.7	140	130.7	140	213	213
	l ₁	-*	-*	-*	135	135	-*	-*	-*	-*	-*	-*	-*	-*	-*
	n	105	105	105	130	130	105	130	130	130	130	130	150	190	190
	o	80	80	80	80	80	65	70	70	90	140	90	140	142	174
	s	15	20	15	20	20	8	25	25	20	25	15	25	15	31
Mass moment of inertia kg m ²	J ^a side	0.353	0.679	0.375	0.528	0.701	0.253	0.512	0.748	1.023	2.254	1.009	2.055	3.608	4.208
	J _B side ²⁾	0.230	0.229	0.306	0.320	0.320	0.315	0.333	0.333	0.890	0.852	1.299	1.324	2.578	2.578
Mass kg ²⁾	28.7	33.4	33.4	38.4	40.7	30.9	38.8	42	62.2	75.6	77.2	91.7	131.5	136.3	213.8

*) Dim l₁ not applicable on this version

1) Dim. l₁ can be modified by moving the connection ring within specified tolerances

2) at max. bore d

FLEXIBLE COUPLINGS

Stromag Periflex® VN Disc Coupling

Stromag Periflex® VP..G Series

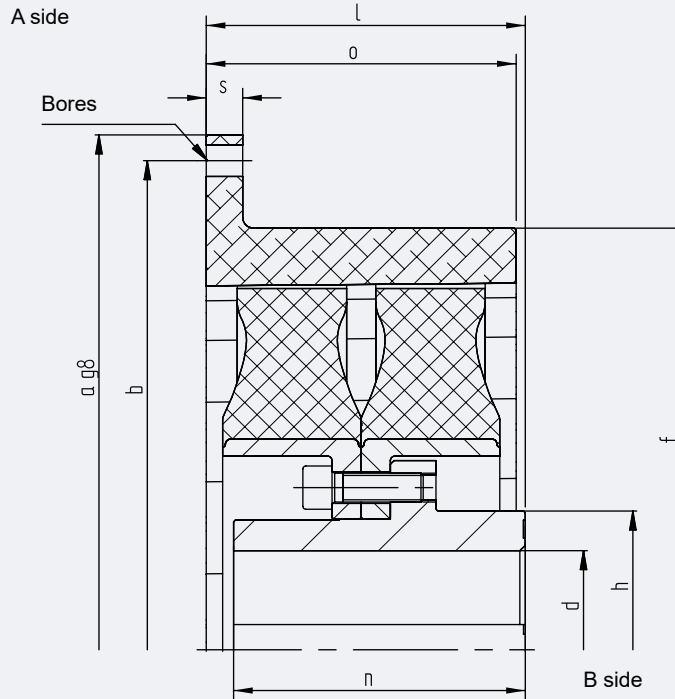

810-00013

Size	PVP 433	PVP 436	PVP 439	PVP 544	PVP 549	PVP 666	PVP 726	
Tire	VN 43311 VN 43331 VN 43321 VN 43341 VN 43351	VN 43611 VN 43631 VN 43621 VN 43641 VN 43651	VN 43911 VN 43931 VN 43941 VN 43951	VN 54411 VN 54431 VN 54421 VN 54441 VN 54451	VN 54911 VN 54931 VN 54921 VN 54941 VN 54951	VN 66611 VN 66631 VN 66621 VN 66641 VN 66651	VN 72611 VN 72631 VN 72621 VN 72641 VN 72651	
SAE Connection	18"	18"	18"	21"	21"	24"	-	
Diameter mm	a	571.5	571.5	571.5	673.1	673.1	733.4	995
	b	542.9	542.9	542.9	641.4	641.4	692.2	950
	d _{max}	100	110	130	160	180	190	250
	f	468	468	455	572	572	692	803
	h	154	168	185	225	300	270	350
Bore k mm	12x17.5	12x17.5	12x17.5	12x17.5	12x17.5	12x20.0	32x21.0	
Lengths mm	l ¹⁾	175	180	180	244	285	286	370
	n	160	160	160	220	200	250	350
	o	170	170	180	220	220	276	324
	s	20	20	25	25	25	31	32
Mass moment of inertia kg m ²	J _{A side}	1.186	1.228	1.205	3.120	3.132	7.702	15.850
	J _{B side} ²⁾	0.439	0.582	0.568	1.587	2.384	4.545	8.730
Mass kg ²⁾	61.7	70.0	67.3	125.0	151.0	229.6	367.4	

1) Dim. l can be modified by moving the connection ring within specified tolerances

2) at max. bore d₁ and d₂

FLEXIBLE COUPLINGS

Stromag Periflex® VN Disc Coupling

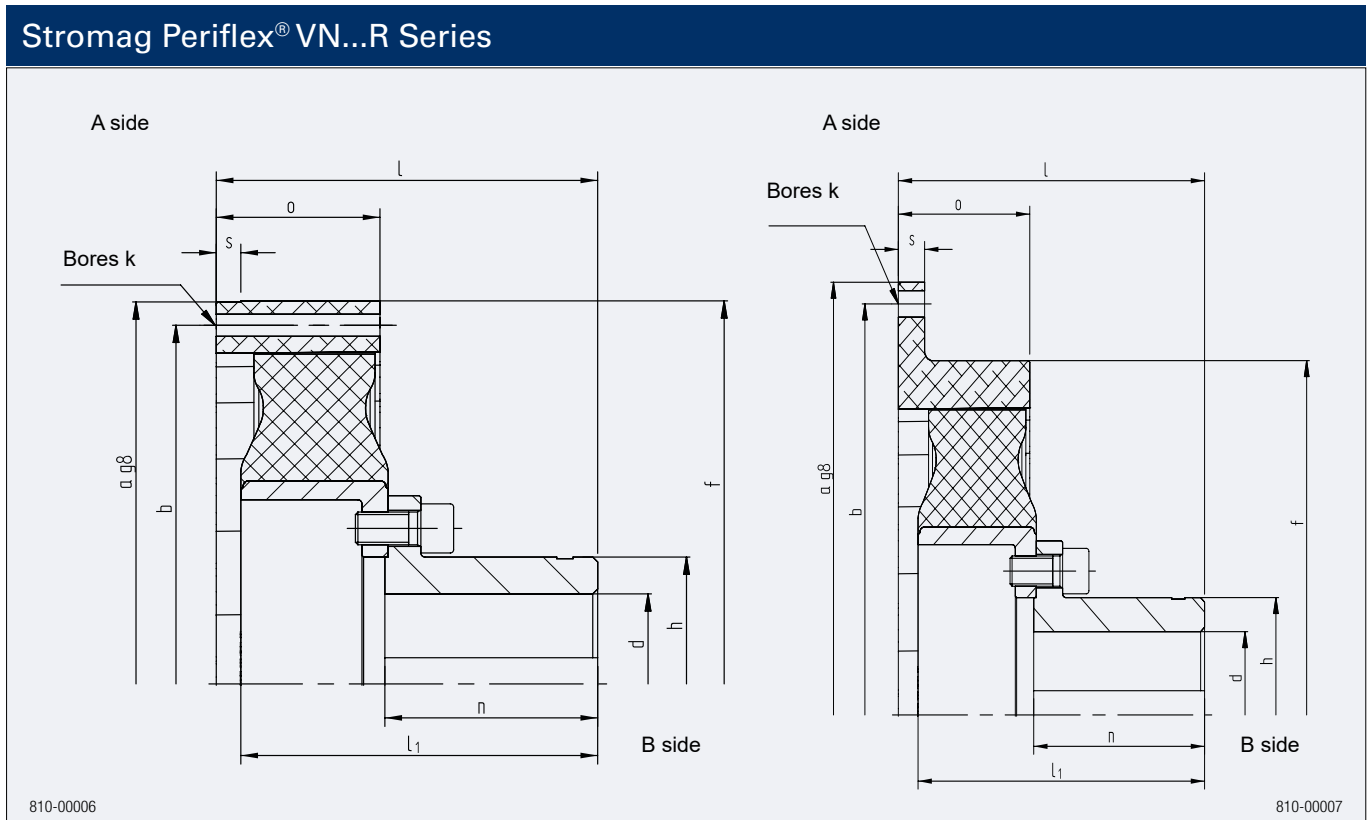

Size	P VN 183		P VN 230		P VN 280		P VN 283		P VN 350		P VN 358		P VN 430				
Tire	VN 18311 VN 18331 VN 18321 VN 18341 VN 18351		VN 23011 VN 23031 VN 23021 VN 23041 VN 23051		VN 28011 VN 28031 VN 28021 VN 28041 VN 28051		VN 28311 VN 28331 VN 28321 VN 28341 VN 28351		VN 35011 VN 35031 VN 35021 VN 35041 VN 35051		VN 35811 VN 35831 VN 35821 VN 35841 VN 35851		VN 43011 VN 43031 VN 43021 VN 43041 VN 43051				
SAE-Connection	6½"	7½"	8"	8"	10"	10"	11½"	10"	11½"	11½"	14"	11½"	14"	14"	18"		
Diameter mm	a	215.9	241.3	263.5	263.5	314.4	314.4	352.4	314.4	352.4	352.4	466.7	352.4	466.7	466.7	571.5	
	b	200	222.3	244.5	244.5	295.3	295.3	333.4	295.3	333.4	333.4	438.2	333.4	438.2	438.2	542.9	
	d _{max}	43	43	43	50	50	55	55	65	65	80	80	85	85	85	85	
	f	218	218	218	266	266	316	316	316	316	355	355	355	355	355	468	468
h	61	61	61	70	70	75	75	90	90	112	112	120	120	120	120	120	
Bore k mm	6x9	8x9	6x11	6x11	8x11	8x11	8x11	8x11	8x11	8x11	8x13.5	8x11	8x13.5	8x13.5	6x17.5		
Lengths mm	l ¹⁾	108	108	108	113	113	125	125	158	158	160	160	170	170	178	178	
	l ₁	93	93	93	98	98	110	110	156	156	147	147	164	164	161	161	
	n	60	60	60	65	65	70	70	105	105	105	105	105	105	105	105	
	o	45	45	45	48.5	48.5	55	55	55	40	55	55	55	55	55	80	80
	s	8	8	8	10	10	10	10	10	10	10	10	10	12	15	20	
Mass moment of inertia kg m ²	J _{A side}	0.0125	0.0429	0.0539	0.0286	0.097	0.0617	0.1421	0.0634	0.0625	0.0998	0.1980	0.1028	0.2063	0.3925	0.7205	
	J _{B side} ²⁾	0.0036	0.0036	0.0036	0.008	0.008	0.0173	0.0173	0.0248	0.0248	0.0533	0.0533	0.0870	0.0870	0.1225	0.1225	
Mass kg ²⁾	3.3	4.75	5.8	4.8	7.8	7.2	10.0	9.1	9.9	13.1	15.5	16.5	18.9	21.4	26.3		

1) Dim. l can be modified by moving the connection ring within specified tolerances

2) at max. bore d

FLEXIBLE COUPLINGS

Stromag Periflex® VN Disc Coupling

Stromag Periflex® VN...R Series

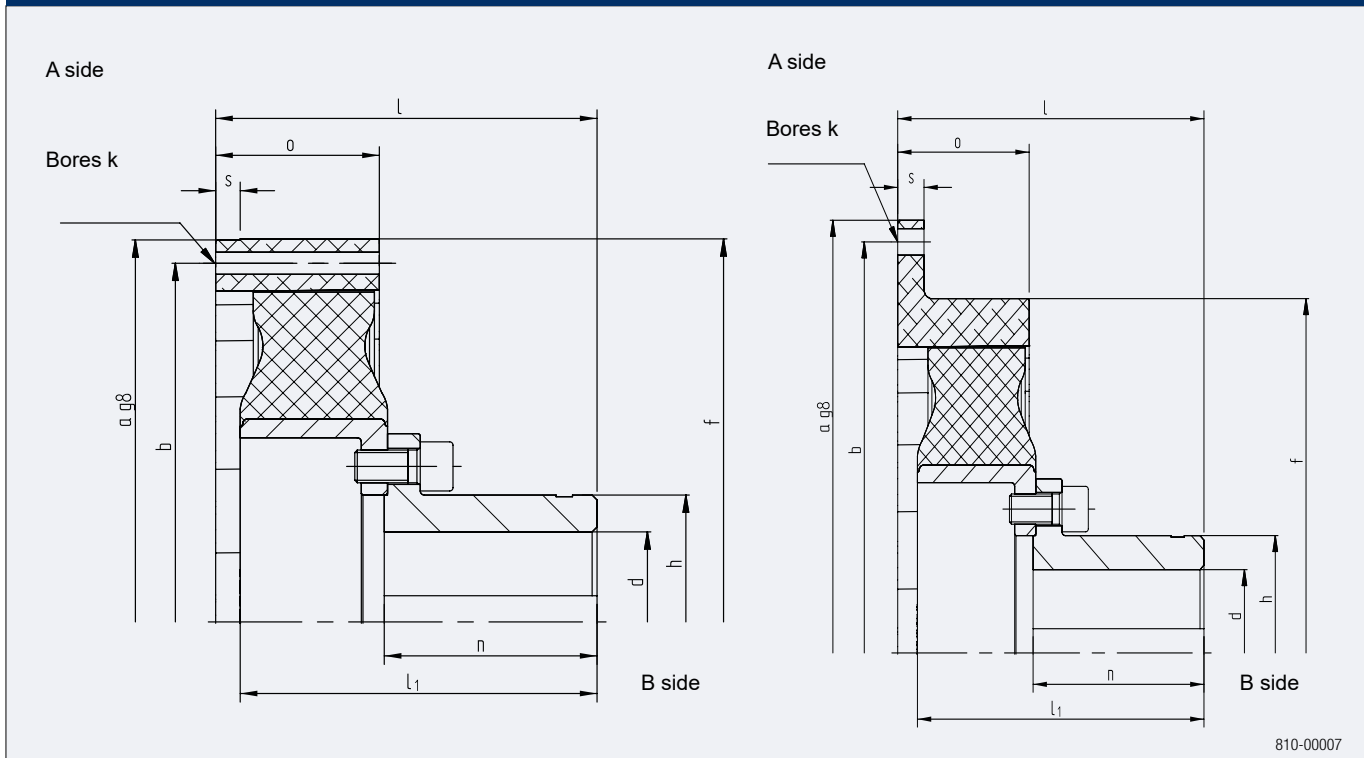

810-00007

Size	P VN 433		P VN 436			P VN 439			P VN 544		P VN 549		P VN 666		P VN 726	
Tire	VN 43311 VN 43331 VN 43321 VN 43341 VN 43351		VN 43611 VN 43631 VN 43621 VN 43641 VN 43651			VN 43911 VN 43931 VN 43941 VN 43951			VN 54411 VN 54431 VN 54421 VN 54441 VN 54451		VN 54911 VN 54931 VN 54921 VN 54941 VN 54951		VN 66611 VN 66631 VN 66621 VN 66641 VN 66651		VN 72611 VN 72631 VN 76221 VN 76241 VN 72651	
SAE Connection	14"	18"	14"	16"	18"	14"	16"	18"	18"	21"	18"	21"	21"	24"	24"	
Diameter mm	a	466.7	571.5	466.7	517.5	571.5	466.7	517.5	571.5	571.5	673.1	571.5	673.1	673.1	733.4	733.4
	b	438.2	542.9	438.2	489	542.9	438.2	489	542.9	542.9	641.4	542.9	641.4	641.4	692.2	692.2
	d_{max}	100	100	110	110	110	130	130	130	160	160	150	150	190	190	250
	f	468	468	468	468	468	468	455	455	572	572	572	572	692	692	761
	h	145	145	155	155	155	182	182	182	225	225	220	220	270	270	350
Bore k mm	8x13.5	6x17.5	8x13.5	8x13.5	6x17.5	8x13.5	8x13.5	6x17.5	12x17.5	12x17.5	12x17.5	12x17.5	12x17.5	12x20.0	24x20.0	
Lengths mm	l_1	209	209	233	233	233	207	227	227	319.5	319.5	307	307	325	325	427
	l_1	199	199	218	218	218	188	208	208	306	306	293.5	293.5	310	310	404
	n	125	125	130	130	130	130	150	150	210	210	210	210	190	190	260
	o	80	80	100	100	100	105	120	120	105	105	105	105	142	142	174
	s	15	20	15	20	20	15	25	25	15	25	20	25	15	31	16
Mass moment of inertia kg m ²	J^A	0.419	0.747	0.522	0.661	0.850	0.569	0.686	0.922	1.235	1.917	1.241	1.923	3.608	4.208	4.865
	J^B side ²⁾	0.241	0.241	0.320	0.320	0.320	0.342	0.342	0.342	1.024	1.024	1.162	1.162	2.623	2.623	6.447
Mass kg ²⁾	32.2	37.1	38.6	41.0	43.5	39.9	43.9	47.1	78.6	51.2	80.6	88.2	133.2	138.0	218.0	

1) Dim. l can be modified by moving the connection ring within specified tolerances

2) at max. bore d

FLEXIBLE COUPLINGS

Stromag Periflex® VN Disc Coupling

Stromag Periflex® VP..R Series

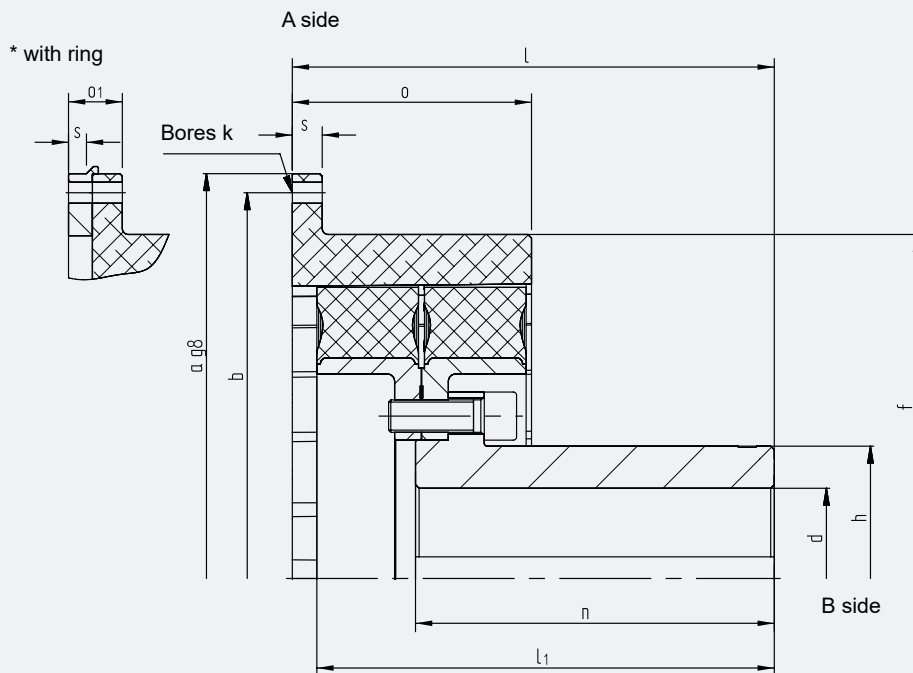

810-00014

Size	PVP 433	PVP 436	PVP 439	PVP 544	PVP 549	PVP 666	PVP 726	
Tire	VN 43311 VN 43331 VN 43321 VN 43341 VN 43351	VN 43611 VN 43631 VN 43621 VN 43641 VN 43651	VN 43911 VN 43931 VN 43941 VN 43951	VN 54411 VN 54431 VN 54421 VN 54441 VN 54451	VN 54911 VN 54931 VN 54921 VN 54941 VN 54951	VN 66611 VN 66631 VN 66621 VN 66641 VN 66651	VN 72611 VN 72631 VN 72621 VN 72641 VN 72651	
SAE Connection	18"	18"	18"	21"	21"	24"	-	
Diameter mm	a	571.5	571.5	571.5	673.1	673.1	733.4	995
	b	542.9	542.9	542.9	641.4	641.4	692.2	950
	d _{max}	100	110	130	160	150	190	250
	f	468	468	455	572	572	692	803
	h	145	155	182	225	220	270	350
Bore k mm	12x17.5	12x17.5	12x17.5	12x17.5	12x17.5	12x20.0	32x21	
Lengths mm	l ¹⁾	344	350	328	336	403	390	514
	l ₁	321	335	308	312	382.5	370	-
	n	250	250	250	220	300	250	350
	o	170	190	180	220	220	276	324
	o ₁	-	40	-	-	-	-	-
	s	20	15	25	25	25	31	32
Mass moment of inertia kg m ²	J ^a side	1.186	2.208	1.205	3.268	2.952	7.748	15.850
	J _B side ²⁾	0.453	0.817	0.651	1.577	2.119	4.519	9.070
Mass kg ²⁾	66.3	86.4	79.7	126.4	149.0	228.2	379.3	

1) Dim. l can be modified by moving the connection ring within specified tolerances

2) at max. bore d

FLEXIBLE COUPLINGS

Stromag Periflex® VN Disc Coupling

Stromag Periflex® VN...S Series

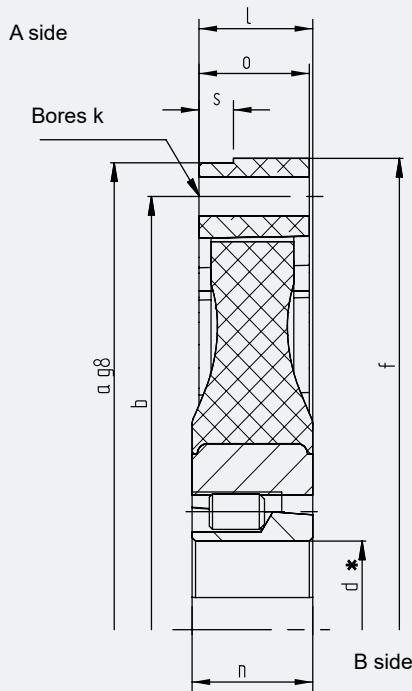

810-00010

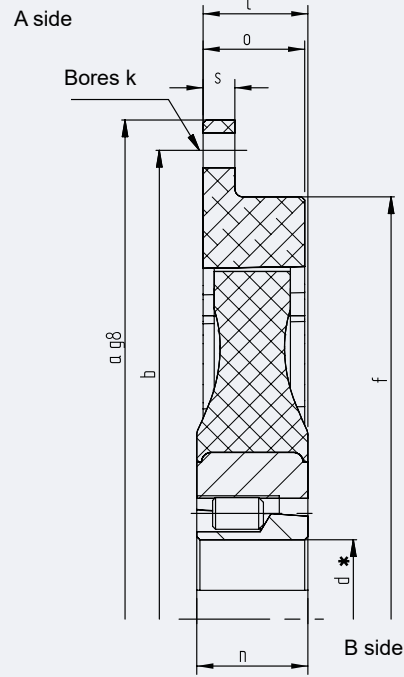

810-00011

Size	PVN 183			PVN 230		PVN 280		PVN 283		PVN 350		PVN 358		
Tire	VN 18311 VN 18331 VN 18321 VN 18341 VN 18351			VN 23011 VN 23031 VN 23021 VN 23041 VN 23051		VN 28011 VN 28031 VN 28021 VN 28041 VN 28051		VN 28311 VN 28331 VN 28321 VN 28341 VN 28351		VN 35011 VN 35031 VN 35021 VN 35041 VN 35051		VN 35811 VN 35831 VN 35821 VN 35841 VN 35851		
SAE Connection	6½"	7½"	8"	8"	10"	10"	11½"	10"	11½"	11½"	14"	11½"	14"	
Clamping bush	2012	2012	2012	2012	2012	2517	2517	3020	3020	3020	3020	3525	3525	
Diameter mm	a	215.9	241.3	263.5	263.5	314.4	314.4	352.4	314.4	352.4	352.4	466.7	352.4	466.7
	b	200	222.3	244.5	244.5	295.3	295.3	333.4	295.3	333.4	333.4	438.2	333.4	438.2
	d*	50	50	50	50	50	60	60	75	75	75	75	95	95
	f	218	218	218	266	266	316	316	316	316	355	355	355	355
Bore k mm	6x9	8x9	6x11	6x11	8x11	8x11	8x11	8x11	8x11	8x11	8x13.5	8x11	8x13.5	
Lengths mm	l ¹⁾	30	30	30	34	34	44	41.5	51	51	56.5	56.5	67	67
	n	31.8	31.8	31.8	31.8	31.8	45	45	51	51	51	51	64	64
	o	25	25	25	32	32	40	40	40	40	55	55	55	55
	s	8	8	8	10	10	10	10	10	10	10	12	10	12
Mass moment of inertia kg m ²	J _{A side}	0.0076	0.0103	0.0134	0.0203	0.0329	0.0483	0.0621	0.0485	0.0625	0.0818	0.2030	0.0842	0.2040
	J _{B side}	0.0032	0.0032	0.0032	0.0076	0.0076	0.0166	0.0166	0.0235	0.0235	0.0559	0.0559	0.1143	0.1220
Mass kg	2.29	2.59	2.78	3.97	4.97	5.67	6.1	6.6	7.2	11.2	14.2	16.4	20.3	

d* max. bore of the taper lock bushing

1) Dim. l can be modified by moving the connection ring within specified tolerances

FLEXIBLE COUPLINGS

Stromag Periflex® VN Disc Coupling

Stromag Periflex® VN...S Series

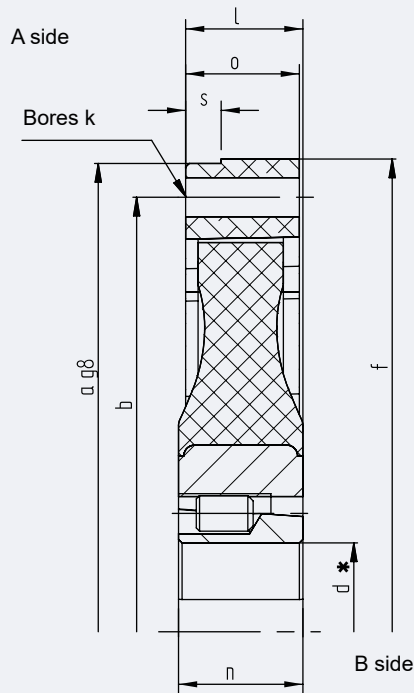

810-00010

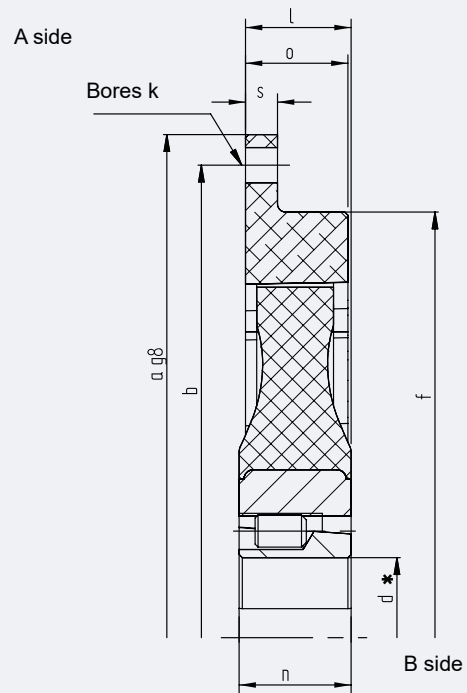

810-00011

Size	PVN 430		PVN 433		PVN 436			PVN 544		
Tire	VN 43011 VN 43031 VN 43021 VN 43041 VN 43051		VN 43311 VN 43331 VN 43321 VN 43341 VN 43351		VN 43611 VN 43631 VN 43621 VN 43641 VN 43651			VN 54411 VN 54431 VN 54421 VN 54441 VN 54451		
SAE Connection	14"	18"	14"	18"	14"	16"	18"	18"	21"	
Clamping bush	3535	3535	4030	4030	4535	4535	4535	5040	5040	
Diameter mm	a	466.7	571.5	466.7	571.5	466.7	517.5	571.5	571.5	673.1
	b	436.2	542.9	438.2	542.9	438.2	489	542.9	542.9	641.4
	d*	90	90	110	110	125	125	125	125	125
	f	468	468	468	468	468	468	468	572	572
Bore k mm	8x13.5	6x17.5	8x13.5	6x17.5	8x13.5	8x13.5	6x17.5	12x17.5	12x17.5	
Lengths mm	l ¹⁾	87.5	100	78	78	85	85	85	99.5	99.5
	n	89	89	76	76	90	90	90	102	102
	o	54	80	80	80	80	80	80	105	140
	s	15	20	15	20	15	20	20	20	25
Mass moment of inertia kg m ²	J _{A side}	0.2905	0.7205	0.419	0.747	0.442	0.579	0.753	1.235	2.254
	J _{B side}	0.1425	0.1425	0.264	0.264	0.356	0.356	0.356	1.086	1.086
Mass kg	20.7	27.7	30.6	35.5	36	38.4	40.6	73.0	84.9	

d* max. bore of the taper lock bushing

1) Dim. l can be modified by moving the connection ring within specified tolerances

FLEXIBLE COUPLINGS

Stromag Periflex® VN Disc Coupling

Stromag Periflex® VN...W Series

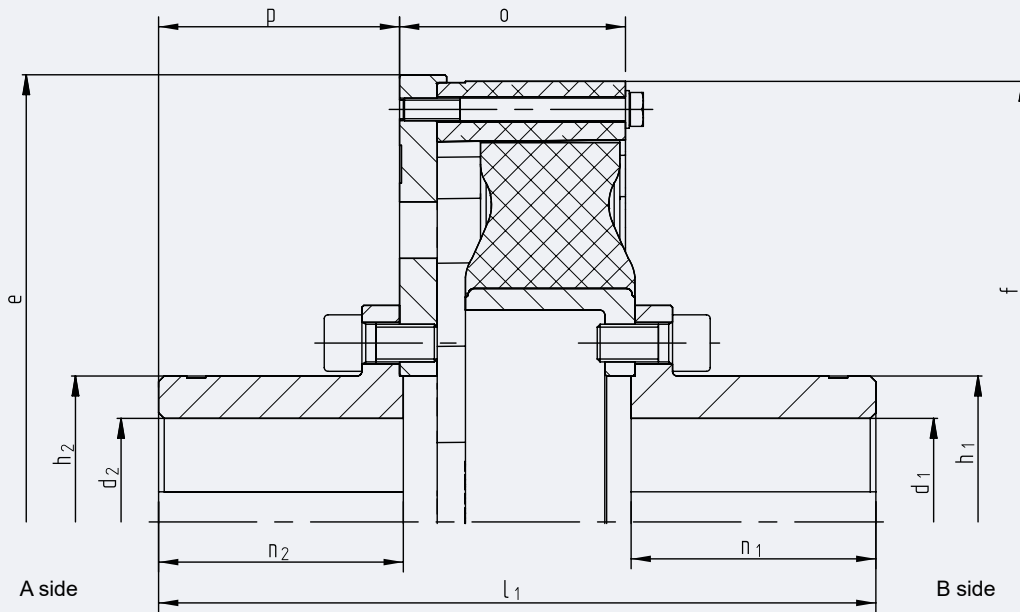

810-00012

Size	PVN 183	PVN 230	PVN 280	PVN 283	PVN 350	PVN 358
Tire	VN 18311 VN 18331 VN 18321 VN 18341 VN 18351	VN 23011 VN 23031 VN 23021 VN 23041 VN 23051	VN 28011 VN 28031 VN 28021 VN 28041 VN 28051	VN 28311 VN 28331 VN 28321 VN 28341 VN 28351	VN 35011 VN 35031 VN 35021 VN 35041 VN 35051	VN 35811 VN 35831 VN 35821 VN 35841 VN 35851
Diameter mm	d_{1max}	43	50	55	65	80
	d_{2max}	43	50	55	65	85
	e	222	271	322	322	360
	f	218	266	316	316	355
	h_1	61	70	75	90	112
	h_2	61	70	75	90	112
Lengths mm	$l^{1)}$	174	186	203	280	279
	n^1	60	65	70	105	105
	n_2	60	65	70	105	105
	o	53	58.5	65	75	71
	p	58	63	68	103	103
Mass moment of inertia $kg\ m^2$	$J_{A\ side^{2)}$	0.0282	0.0716	0.1468	0.1920	0.3190
	$J_{B\ side^{2)}$	0.0038	0.0080	0.0177	0.0275	0.0530
Mass $kg^{2)}$	6.6	9.4	15.2	22.1	30.1	33.8

1) Dim. l can be modified by moving the connection ring within specified tolerances

2) at max. bore d_1 and d_2

FLEXIBLE COUPLINGS

Stromag Periflex® VN Disc Coupling

Stromag Periflex® VN...W Series

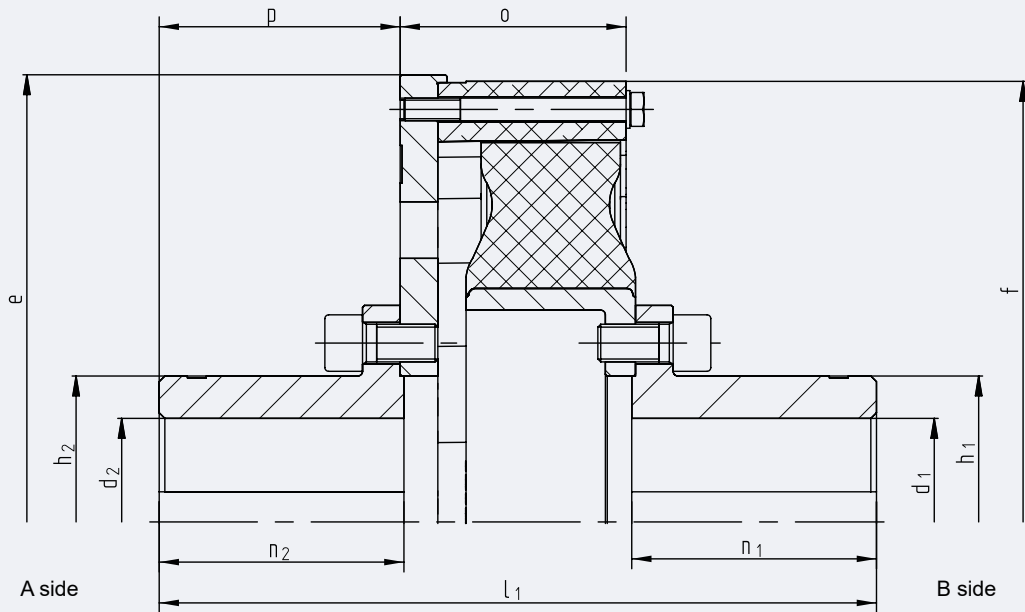

810-00012

Size	PVN 430	PVN 433	PVN 436	PVN 439	PVN 544	PVN 549	PVN 666	PVN 726
Tire	VN 43011 VN 43031 VN 43021 VN 43041 VN 43051	VN 43311 VN 43331 VN 43321 VN 43341 VN 43351	VN 43611 VN 43631 VN 43621 VN 43641 VN 43651	VN 43911 VN 43931 VN 43941 VN 43951	VN 54411 VN 54431 VN 54421 VN 54441 VN 54451	VN 54911 VN 54931 VN 54921 VN 54941 VN 54951	VN 66611 VN 66631 VN 66621 VN 66641 VN 66651	VN 72611 VN 72631 VN 72621 VN 72641 VN 72651
Diameter mm	d_{1max}	85	100	110	130	160	150	190
	d_{2max}	85	100	110	130	160	150	190
	e	475	475	475	475	584	584	683
	f	468	468	468	468	572	572	692
	h_1	120	145	155	182	225	220	270
	h_2	120	145	155	182	225	220	270
Lengths mm	$l^{1)}$	297	352	381	352	548	533	536
	n_1	105	125	130	130	210	210	190
	n_2	105	125	130	130	210	210	190
	o	86	100	120	125	140	125	169
	p	103	123	128	125	206	206	183.5
Mass moment of inertia $kg\ m^2$	J_A side ²⁾	1.015	1.271	1.350	1.385	3.648	3.486	8.985
	J_B side ²⁾	0.123	0.241	0.318	0.352	1.024	1.200	2.623
Mass $kg^{2)}$	47.8	69.3	75.7	81.6	158.0	162.6	254.8	

1) Dim. l can be modified by moving the connection ring within specified tolerances

2) at max. bore d_1 and d_2

FLEXIBLE COUPLINGS

Stromag Periflex® VN Disc Coupling

Stromag Periflex® VP..W Series

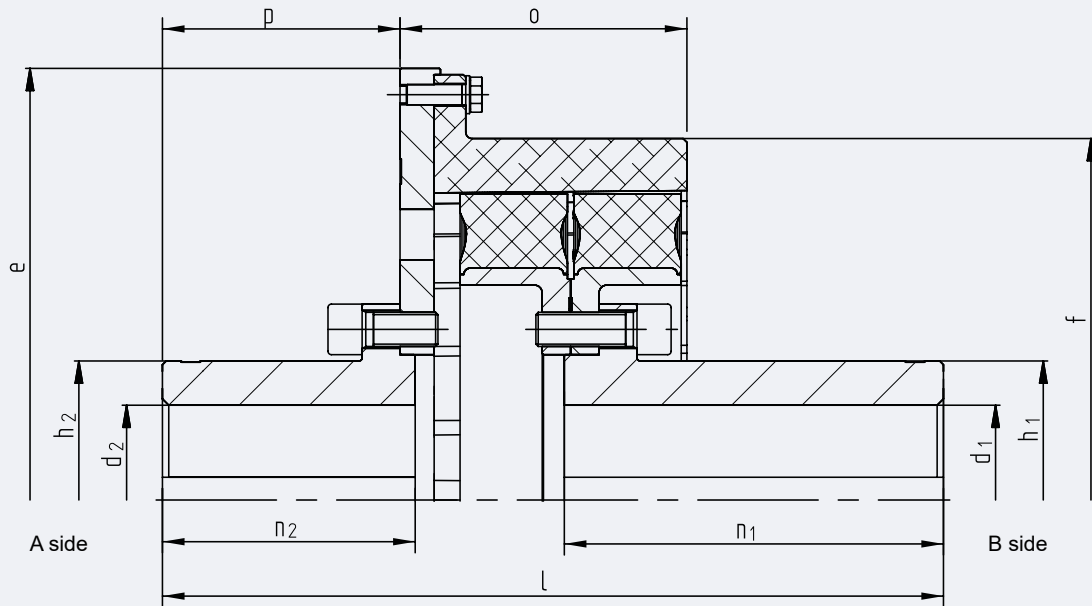

810-00015

Size	PVP 433	PVP 436	PVP 439	PVP 544	PVP 549	PVP 666	PVP 726
Tire	VN 43311 VN 43331 VN 43321 VN 43341 VN 43351	VN 43611 VN 43631 VN 43621 VN 43641 VN 43651	VN 43911 VN 43931 VN 43941 VN 43951	VN 54411 VN 54431 VN 54421 VN 54441 VN 54451	VN 54911 VN 54931 VN 54921 VN 54941 VN 54951	VN 66611 VN 66631 VN 66621 VN 66641 VN 66651	VN 72611 VN 72631 VN 72621 VN 72641 VN 72651
Diameter mm	d_{1max}	100	110	130	160	150	190
	d_{2max}	100	110	130	160	150	190
	e	475	526	526	683	683	744
	f	468	468	455	572	572	692
	h ₁	145	155	182	225	220	270
h ₂	145	155	182	225	220	270	other dimensions on request
Lengths mm	l ¹⁾	519	524	503	569	618	659
	n ₁	250	250	250	220	300	250
	n ₂	160	160	160	210	200	250
	o	190	209	175	247	227	303
	p	155	155	155	206	188	242
Mass moment of inertia kg m ²	J _{A side}	1.744	2.819	2.171	8.101	7.916	15.177
	J _{B side²⁾}	0.612	0.603	0.651	1.577	2.078	4.519
Mass kg ²⁾	102.6	128.0	98.0	234.4	255.8	378.3	

1) Dim. l can be modified by moving the connection ring within specified tolerances

2) at max. bore d_1 and d_2

FLEXIBLE COUPLINGS

Stromag Periflex® VN Disc Coupling

Characteristics

T_{KN}	
The coupling's nominal torque can be permanently transferred over the whole permitted speed range. It must be higher than the system's nominal torque T_N	$T_{KN} \geq T_N$
An application factor of 1.2 is recommended for the simple design of a drive system based exclusively on the nominal torque.	$T_{KN} \geq T_N \cdot 1,2$
T_{Kmax}	
The coupling's max torque T_{Kmax} can be endured as a peak load and may not be exceeded by peak torques T_{max1} when the system is operating in normal, nonstationary mode. A system's normal nonstationary modes are unavoidable and occur repeatedly (e.g. starting/stopping, resonance passes, switchovers, accelerations, etc.).	$T_{Kmax} \geq T_{max1}$
Overloading the Stromag Periflex®VN coupling with peak torques T_{max2} in a system's anomalous nonstationary mode shortens the service life and is tolerated in individual cases. A system's anomalous nonstationary modes are avoidable and are not part of the planned operating scheme (e.g. emergency stops, sync failure, short circuits, etc.).	$T_{Kmax} \cdot 1,5 \geq T_{max2}$
T_{Kw}	
The admissible permanent alternating torque indicates the amplitude of the admissible permanent periodic torque variation. This torque may be superimposed on a base load of T_{KN} . In this process, the maximum damping power P_{KV} must also be checked.	
Ψ	
The relative damping is a measure of the ability of the coupling to convert part of the vibration energy into heat. The data relate to a coupling torque of $0.8 \cdot T_{KN}$, an alternating torque of $0.2 \cdot T_{KN}$, and a frequency of 10 Hz on a coupling at operating temperature, with a surface temperature of about 30°C.	
P_{kv}	
The admissible damping power indicates how much damping (heat) the coupling can permanently absorb resp. dissipate. The sum of the damping power of each vibration order (i.e. ΣP_{vi}) must be less than the damping power of the coupling.	
$P_{vi} = \frac{\pi}{\sqrt{\left(\frac{2\pi}{\Psi}\right)^2 + 1}} \cdot \frac{T_{wi}^2 \cdot f_i}{C_{tdyn}}$ $P_{KV} \geq \Sigma P_{vi}$	
The stated value P_{KV60} describes the damping power which can be absorbed over the period of 1 hour. To determine the damping power which can be permanently absorbed ($P_{KV\infty}$), the value P_{KV60} has to be multiplied by the factor 0.5. With an ambient temperature T_U higher than 30°C, the admissible damping power must be reduced by the temperature factor $S_{\vartheta PKV}$	$P_{KV}(T_U) = \frac{P_{KV}}{S_{\vartheta PKV}}$

FLEXIBLE COUPLINGS

Stromag Periflex® VN Disc Coupling

Characteristics

Temperature factors S_{9PKV}

Temperature factors shall take into consideration the reduction of the physical characteristics of rubber-flexible material caused by heating.

The coupling temperature is determined by the ambient temperature plus an internal heating caused by internal material friction in the rubber volume, resulting from alternating torques and alternating loads due to shaft offsets.

With higher ambient temperatures the coupling characteristic value P_{KV} must be reduced through the corresponding temperature factor S_{9PKV} .

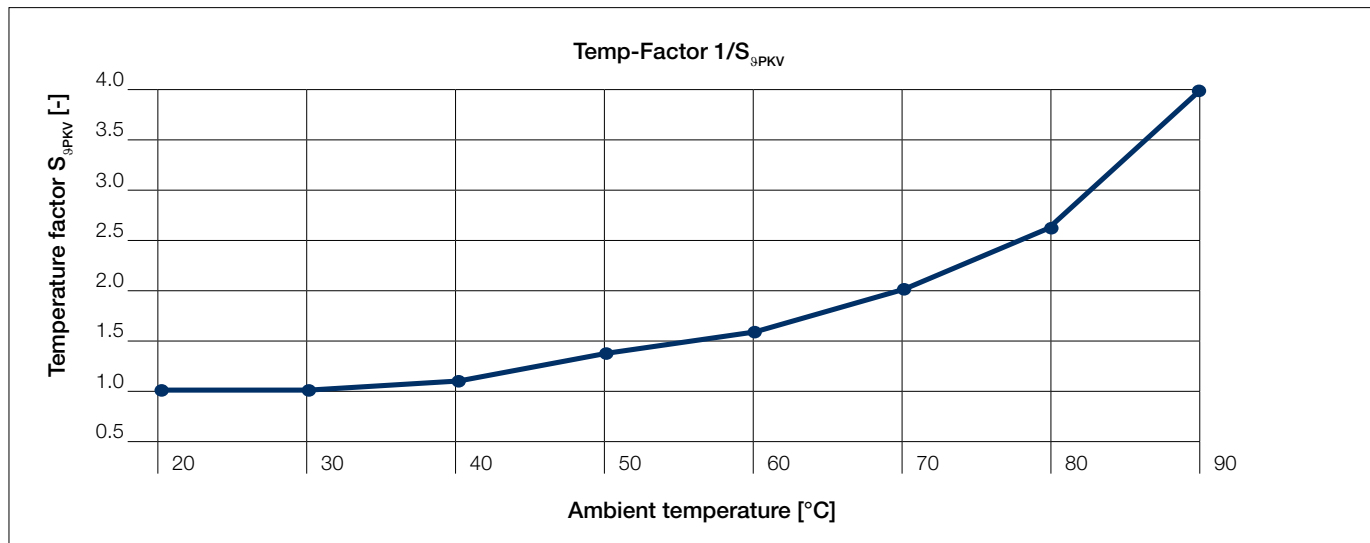

ΔK_a

Maximum axial displacement of the coupling. The shafts' axial displacement ΔW_a must be less than ΔK_a .

The axial displacement for Stromag Periflex® VN couplings depends on the installed connection ring.

The disc tire must always lie over its full width in the connection ring.

$$\Delta K_a \geq \Delta W_a$$

ΔK_r

Maximum radial displacement of the coupling.

The shafts' radial displacement ΔW_r must be less than ΔK_r .

$$\Delta K_r \geq \Delta W_r$$

ΔK_w

Maximum angular displacement of the coupling.

The shafts' angular displacement ΔW_w must be less than ΔK_w .

A ΔK_w value of 0.5° is permitted for Periflex® VN couplings. This value, however, may be utilised to the full only when there are no other options for shaft displacement.

$$\Delta K_w \geq \Delta W_w$$

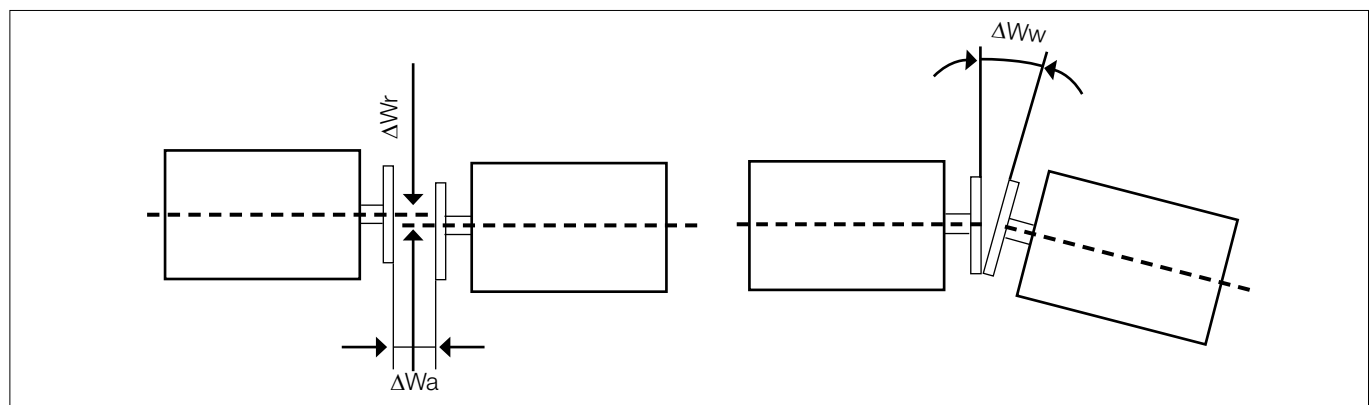

FLEXIBLE COUPLINGS

Stromag Periflex® VN Disc Coupling

Characteristics

C_a	
<p>The axial spring stiffness represents the ratio of axial reaction force to axial displacement.</p> <p>Stromag Periflex® VN couplings do not generate axial forces when the disc tire lies over its full width in the connection ring.</p>	$C_a = 0$
C_r	
<p>The radial stiffness represents the ratio of radial reaction force to radial displacement.</p> <p>The specified values apply to the coupling at operating temperature, with a surface temperature of about 30°C.</p>	
C_{Tdyn}	
<p>The dynamic torsional spring stiffness represents the ratio of torque amplitude to torque angle during an oscillation.</p> <p>The torque amplitude is superimposed on an initial load (coupling torque). The Stromag Periflex® VN coupling's C_{Tdyn} value remains constant over the coupling torque (linear characteristic curve), but changes with the amplitude, frequency, and temperature of the flexible element.</p> <p>The specified nominal values for C_{Tdyn} are based on a coupling torque of $0.8 \cdot T_{KN}$, an alternating torque of $0.2 \cdot T_{KN}$, and a frequency of 10 Hz on a coupling at operating temperature, with a surface temperature of about 30°C.</p>	
<p>C_{Tdyn warm}</p> <p>takes into account that high power dissipation causes the coupling to heat up.</p>	$C_{Tdyn\ warm} = 0.7 \cdot C_{Tdyn}$
<p>C_{Tdyn A}</p> <p>takes into account the effects of a small alternating torque amplitude.</p>	$C_{Tdyn\ A} = 1.35 \cdot C_{Tdyn}$
<p>Calculations of torsional vibrations in the system are recommended to include C_{Tdyn warm} (0.7), und C_{Tdyn A} (1.35)</p>	

FLEXIBLE COUPLINGS

Stromag Periflex® VN Disc Coupling

Coupling Design, question sheet

MAIN ENGINE		
Engine type (electric, combustion engine, etc.)		
Engine full designation		
Engine installation (rigid or flexible)		
Engine housing (SAE)		
Flywheel connection		Inch
Engine mass moment of inertia		kgm ²
Flywheel mass moment of inertia (for combustion engine)		kgm ²
Nominal power		kW
Nominal speed		rpm
Speed range (if application operates within a speed range)		rpm
Maximum torque (breakdown torque)		Nm
GEAR		
Gear ratio		
Moment of inertia		kgm ²
CARDAN SHAFT		
Type of cardan shaft deflection ("z" or "w")		
Cardan shaft type (manufacturer, size)		
Deflection angle		°
Moment of inertia		kgm ²
Length of the cardan shaft		mm
DRIVEN SIDE		
Type (generator, fan, compressor, fixed or variable pitch propeller)		
Main or auxiliary drive		
Type of construction (free-standing or flange-mounted?)		
Free-standing type (rigid or flexible installation?)		
Number of blades (in case of propeller application)		
Moment of inertia of driven side		kgm ²
Shaft length (l) and diameter (d)		mm
COUPLING		
Location in the drive train (enclose schematic diagram)		
Bore dimension for coupling hub		mm
Ambient temperature near the coupling		°C, °K
Maximum permissible coupling length		mm
Classification society		
ATEX certification		
Ice class		

FLEXIBLE COUPLINGS

Stromag Periflex® VN Disc Coupling

Use in potentially explosive environments, question sheet

Applications		<input type="radio"/>	Group II (above ground)
Potentially explosive atmosphere of air and		<input type="radio"/>	gas
		<input type="radio"/>	dust
Zone (Category)	gas	<input type="radio"/>	Zone 1 (Category 2G)
		<input type="radio"/>	Zone 2 (Category 3G)
	dust	<input type="radio"/>	Zone 22 not electrically conducting (Category 3D)
Temperature category in atmosphere with gas	gas	<input type="radio"/>	T1
		<input type="radio"/>	T2
		<input type="radio"/>	T3
		<input type="radio"/>	T4
Max surface temperature	dust	<input type="radio"/>	125 °C
		<input type="radio"/>	< 120 °C
		<input type="radio"/>	-20 °C to + 40 °C
Ambient temperature		<input type="radio"/>	other ambient temperatures only with certain restrictions



Stop seeing individual parts. Start seeing unlimited possibilities.

Regardless of your objectives or the challenges with your application, Powertrain Solutions can help you achieve your unique goals. No matter what your application looks like, it relies on many components, all working together. But not all components are made to work together reliably and efficiently. Powertrain Solutions has the insight, experience and expertise to engineer your collection of components into a fully optimized system — giving you solutions that boost efficiency, improve reliability and performance, lower costs and simplify ordering and logistics.

WHERE OTHERS SEE PARTS, WE SEE A SYSTEM



Bearings



Belt & Chain
Drives



Clutches &
Brakes



Conveying



Disc & Gear
Couplings



Motors



Speed Reducers
& Gearboxes



Monitoring &
Diagnostics

It's time to see the bigger picture.

Get started at RegalRexnord.com/Powertrain



Regal Rexnord

[regalrexnord.com](https://www.regalrexnord.com)

Stromag GmbH

Hansatraße 120

59425 Unna - Germany

+49 2303 102 - 0

[Stromag.com](https://www.stromag.com)

The proper selection and application of products and components, including assuring that the product is safe for its intended use, are the responsibility of the customer. To view our Application Considerations, please visit <https://www.regalrexnord.com/Application-Considerations>.

To view our Standard Terms and Conditions of Sale, please visit <https://www.regalrexnord.com/Terms-and-Conditions-of-Sale>.

"Regal Rexnord" is not indicative of legal entity. Refer to product purchase documentation for the applicable legal entity.

Regal Rexnord and Stromag are trademarks of Regal Rexnord Corporation or one of its affiliated companies.

©2024 Regal Rexnord Corporation, All Rights Reserved.
MCC-P-8462-SG A4-EN 08/24

