

RATO R+

TECHNISCHE DATEN TECHNICAL DATA





SCAN →



Bitte benutzen Sie Ihr Smartphone mit der entsprechenden Software, scannen Sie den QR-Code ein.

Please use your smartphone with the relevant software, scan the QR-Code.

GET INFO →



Sie erhalten die Information, ob dies die aktuellste Version ist.

You will get the information whether you have got the latest version.



07/2019

Das Handsymbol kennzeichnet Seiten, auf denen es eine Veränderung zur Vorgängerversion gibt.
The hand symbol appears on pages which differ from the previous catalogue version.

INHALT CONTENTS

Eigenschaften	04	Characteristics	04
Baureihenübersicht	06	Summary of Series	06
Technische Daten	08	Technical Data	08
Leistungsdaten	08	Performance Data	08
Geometrische Daten	10	Geometric Data	10
Baureihe 2200	10	Series 2200	10
Baureihe 2201	14	Series 2201	14
Baureihe 2400	16	Series 2400	16
Erläuterungen des Productcodes	18	Explanations of the Product Code	18
Online-Service	22	Online-Service	22
Gültigkeitsklausel	23	Validity Clause	23



DREHMOMENT TORQUE

26.5 kNm – 530.0 kNm

EINSATZGEBIETE

Flexibel aufgestellte Anlagen, starr aufgestellte Anlagen.

Mit der Einführung der RATO R+ führt VULKAN den Erfolg der ACOTEC-Serie fort. Die neuentwickelten ACOTEC-Produkte zeichnen sich durch eine gesteigerte Leistungsfähigkeit in den wesentlichen technischen Daten aus. Das bewährte Konstruktionsprinzip der Standard RATO R wurde bei ihrer ACOTEC-Variante beibehalten, Kunden können sich folglich auf eine Gleichteileverwendung mit bestehendem RATO R Programm verlassen. Die RATO R+ ist eine hochelastische Kupplung speziell für die Anwendung in Antriebsanlagen mit der Forderung nach hoher Drehnachgiebigkeit, guten Verlagerungseigenschaften und möglichst geringen rotierenden Massen entwickelt worden. Bei der Produktweiterentwicklung wurde das Augenmerk vor allem auf das Herzstück der Kupplung gelegt: das Elastomer. Innovative Compoundforschung und hochspezialisierte Vulkanisationstechnologie ermöglichten die Entwicklung eines Elastomers mit wesentlich höherer Leistungsdichte.

PRODUKTVORTEILE

- ⊕ Kleinere Kupplung mit höherer Leistungsdichte sorgt für ein gutes Preis-Leistungsverhältnis
- ⊕ Mit geringen rotierenden Massen optimiert für den Trend zu leistungsstarken und hoch drehenden Motoren
- ⊕ Thermische Beständigkeit und geringere Alterungseffekte des ACOTEC-Elastomers garantiert hohe Lebensdauer
- ⊕ Maximale Lösungsflexibilität durch sehr gute Integrierbarkeit in verschiedene Anlagen

AREAS OF APPLICATION

Flexibly mounted engines, rigidly mounted engines.

VULKAN has continued the success of the ACOTEC range with the launch of the RATO R+. The proven principle of construction of the standard RATO R was retained with the ACOTEC variant. Utilization of same parts with the proven and field-tested RATO R guarantees highest levels of functional reliability. The RATO R+ coupling has been specially designed for the use in installations requiring a high level of torsional flexibility and misalignment capacity. Inherent features of the design include high dynamic load capacity and good rotational dynamic properties due to the low rotating inertias. The area of application is primarily high-speed main/PTO systems driven by a diesel engine or electric motor.

PRODUCT BENEFITS

- ⊕ Smaller coupling with greater power density provides a good price-performance ratio
- ⊕ With low rotating masses, it is optimised for the trend towards high-performance and high-speed engines
- ⊕ Thermal resistance and lower ageing effects of the ACOTEC elastomer ensures long service life
- ⊕ Maximum flexibility in providing a solution considering that it can be easily integrated in different systems

RATO R+

BAUREIHENÜBERSICHT SUMMARY OF SERIES

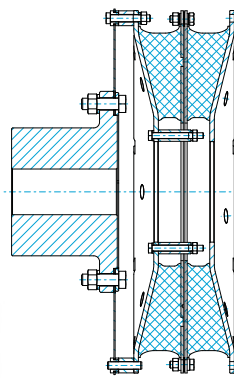

2200

BAUREIHE SERIES

Seite 10 Page 10

Zur Verbindung eines Schwungrades
mit einer Welle.

For connecting a flywheel
with a shaft.

Baugruppe Dimension Group	G 2D10 – G 5H20
Nenn Drehmoment Nominal Torque	26.50 kNm – 530.00 kNm

2200

BAUREIHE SERIES

Seite 12 Page 12

Zur Verbindung eines Schwungrades
mit einer Welle.

For connecting a flywheel
with a shaft.

Baugruppe Dimension Group	G 4EP0 – G 5HP0
Nenn Drehmoment Nominal Torque	190.00 kNm – 530.00 kNm

2201 BAUREIHE SERIES

Seite 14 Page 14

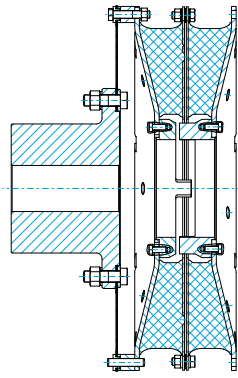

Zur Verbindung eines Schwungrades
mit einer Welle.

For connecting a flywheel
with a shaft.

Mit Durchdrehsicherung.

With torsional limit device.

Baugruppe Dimension Group

G 2D10 – G 4A20

Nenn Drehmoment Nominal Torque

26.50 kNm – 176.00 kNm

2400 BAUREIHE SERIES

Seite 18 Page 18

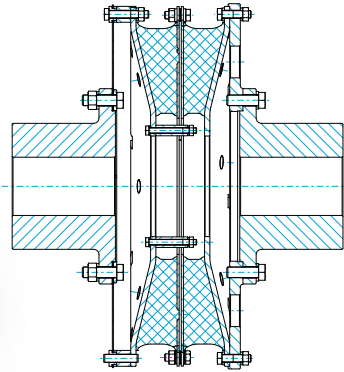
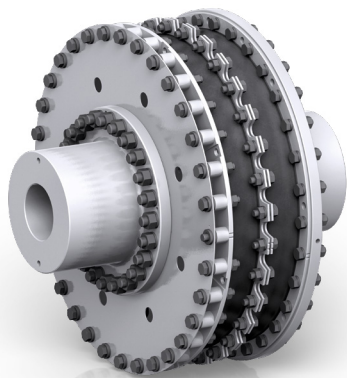

Zur Verbindung zweier Wellen.

For the connection of two shafts.

Baugruppe Dimension Group

G 2D10 – G 4A20

Nenn Drehmoment Nominal Torque

26.50 kNm – 176.00 kNm

LEISTUNGSDATEN PERFORMANCE DATA

Kupplungstyp Type of Coupling		T_{KN}	T_{Kmax1}	T_{Kmax2}	ΔT_{Kmax}	T_{KW}	P_{KV30}	$n_{Kmax}^{1)}$	$\Delta K_r^{1)}$	ΔK_a	C_{rdyn}	$C_{tdyn}^{1)2)}$	$\psi^{1)2)}$
		[kNm]	[kNm]	[kNm]	[kNm]	[kNm]	[kW]	[1/min]	[mm]	[mm]	[kN/mm]	[kNm/rad] nominal	nominal
Größe Size	Baugruppe Dimension Group	Nennmoment Nominal Torque	Max. Drehmoment ₁ Max. Torque ₁	Max. Drehmoment ₂ Max. Torque ₂	Drehmoment Bereich Torque Range	Wechsel- drehmoment Vibratory Torque	Verlustleistung Power Loss	Drehzahl Rotational Speed	Radialer Kupplungsversatz Radial Coupling Displacement	Axialer Kupplungsversatz Axial Coupling Displacement	Radiale Federsteife Radial Stiffness	Dynamische Drehfedersteife Dynamic Torsional Stiffness	Verhältnismäßige Dämpfung Relative Damping
G 2D1S	G2D10	26,5	40,0	120,0	29,5	6,6	0,60	2350	5,9	5,5	3,6	144	0,75
G 2D1M	G2D10	28,5	43,0	128,0	33,5	7,0	0,60	2350	4,6	5,5	5,0	204	0,90
G 2D1H	G2D10	31,5	47,0	142,0	40,0	8,0	0,60	2350	3,6	5,5	6,4	261	1,13
G 2D2S	G2D20	26,5	40,0	120,0	29,5	6,6	1,20	2350	11,8	5,5	1,8	72	0,75
G 2D2M	G2D20	28,5	43,0	128,0	33,5	7,0	1,20	2350	9,2	5,5	2,5	102	0,90
G 2D2H	G2D20	31,5	47,0	142,0	40,0	8,0	1,20	2350	7,2	5,5	3,2	131	1,13
G 2F1S	G2F10	34,0	51,0	153,0	37,5	8,5	0,65	2125	6,3	6,0	3,8	176	0,75
G 2F1M	G2F10	36,0	54,0	162,0	42,0	9,0	0,65	2125	5,2	6,0	4,6	220	0,90
G 2F1H	G2F10	40,0	60,0	180,0	50,5	10,0	0,65	2125	4,0	6,0	6,2	300	1,13
G 2F2S	G2F20	34,0	51,0	153,0	37,5	8,5	1,31	2125	12,6	6,0	1,9	88	0,75
G 2F2M	G2F20	36,0	54,0	162,0	42,0	9,0	1,31	2125	10,4	6,0	2,3	110	0,90
G 2F2H	G2F20	40,0	60,0	180,0	50,5	10,0	1,31	2125	8,0	6,0	3,1	150	1,13
G 2G1S	G2G10	41,5	62,0	187,0	47,5	10,0	0,71	2000	6,3	6,0	4,4	246	0,75
G 2G1M	G2G10	44,0	66,0	198,0	53,5	11,0	0,71	2000	5,2	6,0	5,4	300	0,90
G 2G1H	G2G10	51,0	76,5	230,0	64,0	13,0	0,71	2000	4,1	6,0	7,0	390	1,13
G 2G2S	G2G20	41,5	62,0	187,0	47,5	10,0	1,41	2000	12,6	6,0	2,2	123	0,75
G 2G2M	G2G20	44,0	66,0	198,0	53,5	11,0	1,41	2000	10,4	6,0	2,7	150	0,90
G 2G2H	G2G20	51,0	76,5	230,0	64,0	13,0	1,41	2000	8,2	6,0	3,5	195	1,13
G 3B1S	G3B10	66,5	100,0	300,0	75,0	17,0	0,80	1675	7,8	7,0	4,8	360	0,75
G 3B1M	G3B10	70,0	105,0	315,0	84,0	17,5	0,80	1675	5,6	7,0	6,6	504	0,90
G 3B1H	G3B10	80,0	120,0	360,0	100,5	20,0	0,80	1675	4,5	7,0	8,8	658	1,13
G 3B2S	G3B20	66,5	100,0	300,0	75,0	17,0	1,60	1675	15,6	7,0	2,4	180	0,75
G 3B2M	G3B20	70,0	105,0	315,0	84,0	17,5	1,60	1675	11,2	7,0	3,3	252	0,90
G 3B2H	G3B20	80,0	120,0	360,0	100,5	20,0	1,60	1675	9,0	7,0	4,4	329	1,13
G 3C1S	G3C10	83,0	125,0	374,0	95,0	21,0	0,83	1100	9,1	5,5	5,2	450	0,65
G 3C1M	G3C10	90,0	135,0	405,0	97,0	22,5	0,83	1100	6,7	5,5	7,2	640	0,85
G 3C1H	G3C10	100,0	150,0	450,0	116,5	25,0	0,83	1100	5,5	5,5	9,2	810	1,00
G 3C2S	G3C20	83,0	125,0	374,0	95,0	21,0	1,65	1100	18,2	5,5	2,6	225	0,65
G 3C2M	G3C20	90,0	135,0	405,0	97,0	22,5	1,65	1100	13,4	5,5	3,6	320	0,85
G 3C2H	G3C20	100,0	150,0	450,0	116,5	25,0	1,65	1100	11,0	5,5	4,6	405	1,00
G 3E1S	G3E10	100,0	150,0	450,0	121,5	25,0	1,12	1545	7,1	7,0	8,2	860	0,65
G 3E1M	G3E10	110,0	165,0	495,0	142,5	27,5	1,12	1545	5,2	7,0	11,4	1200	0,85
G 3E1H	G3E10	125,0	188,0	560,0	171,0	31,0	1,12	1545	4,5	7,0	13,0	1350	1,00
G 3E1X	G3E10	125,0	188,0	560,0	171,0	31,0	1,12	1545	3,9	7,0	16,2	1700	1,10
G 3E2S	G3E20	100,0	150,0	450,0	121,5	25,0	2,24	1545	14,2	7,0	4,1	430	0,65
G 3E2M	G3E20	110,0	165,0	495,0	142,5	27,5	2,24	1545	10,4	7,0	5,7	600	0,85
G 3E2H	G3E20	125,0	188,0	560,0	171,0	31,0	2,24	1545	9,0	7,0	6,5	675	1,00
G 3E2X	G3E20	125,0	188,0	560,0	171,0	31,0	2,24	1545	7,8	7,0	8,1	850	1,10
G 4A1S	G4A10	137,0	205,0	616,0	190,0	34,0	1,07	900	10,8	9,0	5,8	800	0,65
G 4A1M	G4A10	154,0	231,0	693,0	212,0	38,0	1,07	900	7,8	9,0	8,4	1150	0,85
G 4A1H	G4A10	176,0	264,0	792,0	247,0	44,0	1,07	900	6,4	9,0	10,8	1500	1,00
G 4A1X	G4A10	198,0	297,0	891,0	278,0	49,5	1,07	900	5,3	9,0	14,0	1950	1,10
G 4A2S	G4A20	137,0	205,0	616,0	190,0	34,0	2,13	900	21,6	9,0	2,9	400	0,65
G 4A2M	G4A20	154,0	231,0	693,0	212,0	38,0	2,13	900	15,6	9,0	4,2	575	0,85
G 4A2H	G4A20	176,0	264,0	792,0	247,0	44,0	2,13	900	12,8	9,0	5,4	750	1,00
G 4A2X	G4A20	198,0	297,0	891,0	278,0	49,5	2,13	900	10,6	9,0	7,0	975	1,10

LEISTUNGSDATEN PERFORMANCE DATA

Kupplungstyp Type of Coupling		T_{KN}	T_{Kmax1}	T_{Kmax2}	ΔT_{Kmax}	T_{KW}	P_{KV30}	$n_{Kmax}^{1)}$	$\Delta K_r^{1)}$	ΔK_a	C_{rdyn}	$C_{Tdyn}^{1)2)}$	$\psi^{1)2)}$
		[kNm]	[kNm]	[kNm]	[kNm]	[kNm]	[kW]	[1/min]	[mm]	[mm]	[kN/mm]	[kNm/rad] nominal	nominal
Größe Size	Baugruppe Dimension Group	Nenn Drehmoment Nominal Torque	Max. Drehmoment ₁ Max. Torque ₁	Max. Drehmoment ₂ Max. Torque ₂	Drehmoment Bereich Torque Range	Wechsel-drehmoment Vibratory Torque	Verlustleistung Power Loss	Drehzahl Rotational Speed	Radialer Kupplungsversatz Radial Coupling Displacement	Axialer Kupplungsversatz Axial Coupling Displacement	Radiale Federsteife Radial Stiffness	Dynamische Drehfedersteife Dynamic Torsional Stiffness	Verhältnismäßige Dämpfung Relative Damping
G 4E1S	G4E10	190,0	285,0	855,0	380,0	47,5	1,13	880	10,8	17,7	6,8	1140	0,60
G 4E1M	G4E10	210,0	315,0	945,0	420,0	52,5	1,13	880	8,9	17,7	8,6	1470	0,70
G 4E1H	G4E10	230,0	345,0	1035,0	460,0	57,5	1,13	880	7,4	17,7	10,8	1840	0,80
G 4E1X	G4E10	250,0	375,0	1125,0	500,0	62,5	1,13	880	6,3	17,7	13,2	2250	0,90
G 4E2S	G4E20	190,0	285,0	855,0	380,0	47,5	2,27	880	21,6	17,7	3,4	570	0,60
G 4E2M	G4E20	210,0	315,0	945,0	420,0	52,5	2,27	880	17,8	17,7	4,3	735	0,70
G 4E2H	G4E20	230,0	345,0	1035,0	460,0	57,5	2,27	880	14,8	17,7	5,4	920	0,80
G 4E2X	G4E20	250,0	375,0	1125,0	500,0	62,5	2,27	880	12,6	17,7	6,6	1125	0,90
G 4EPS	G4EPO	190,0	285,0	855,0	380,0	66,5	2,26	880	6,4	8,4	28,6	4750	0,80
G 4EPM	G4EPO	210,0	315,0	945,0	420,0	73,5	2,26	880	5,6	8,4	34,1	5670	0,90
G 4EPH	G4EPO	230,0	345,0	1035,0	460,0	80,5	2,26	880	4,9	8,4	40,1	6670	1,00
G 4EPX	G4EPO	250,0	375,0	1125,0	500,0	87,5	2,26	880	4,3	8,4	46,6	7750	1,10
G 5B1S	G5B10	290,0	435,0	1305,0	580,0	72,5	1,39	710	12,6	20,8	7,6	1740	0,60
G 5B1M	G5B10	320,0	480,0	1440,0	640,0	80,0	1,39	710	10,2	20,8	9,8	2240	0,70
G 5B1H	G5B10	350,0	525,0	1575,0	700,0	87,5	1,39	710	8,4	20,8	12,6	2800	0,80
G 5B1X	G5B10	380,0	570,0	1710,0	760,0	95,0	1,39	710	7,3	20,8	15,0	3420	0,90
G 5B2S	G5B20	290,0	435,0	1305,0	580,0	72,5	2,77	710	25,2	20,8	3,8	870	0,60
G 5B2M	G5B20	320,0	480,0	1440,0	640,0	80,0	2,77	710	20,4	20,8	4,9	1120	0,70
G 5B2H	G5B20	350,0	525,0	1575,0	700,0	87,5	2,77	710	16,8	20,8	6,3	1400	0,80
G 5B2X	G5B20	380,0	570,0	1710,0	760,0	95,0	2,77	710	14,6	20,8	7,5	1710	0,90
G 5BPS	G5BPO	290,0	435,0	1305,0	580,0	101,5	2,72	710	7,4	9,7	32,4	7250	0,80
G 5BPM	G5BPO	320,0	480,0	1440,0	640,0	112,0	2,72	710	6,4	9,7	38,6	8640	0,90
G 5BPH	G5BPO	350,0	525,0	1575,0	700,0	122,5	2,72	710	5,6	9,7	45,4	10150	1,00
G 5BPX	G5BPO	380,0	570,0	1710,0	760,0	133,0	2,72	710	4,9	9,7	52,7	11780	1,10
G 5H1S	G5H10	400,0	600,0	1800,0	800,0	100,0	1,51	710	12,3	23,3	8,6	2400	0,60
G 5H1M	G5H10	440,0	660,0	1980,0	880,0	110,0	1,51	710	10,1	23,3	11,0	3080	0,70
G 5H1H	G5H10	480,0	720,0	2160,0	960,0	120,0	1,51	710	8,5	23,3	13,6	3840	0,80
G 5H1X	G5H10	530,0	795,0	2385,0	1060,0	132,5	1,51	710	7,1	23,3	17,0	4770	0,90
G 5H2S	G5H20	400,0	600,0	1800,0	800,0	100,0	3,01	710	24,6	23,3	4,3	1200	0,60
G 5H2M	G5H20	440,0	660,0	1980,0	880,0	110,0	3,01	710	20,2	23,3	5,5	1540	0,70
G 5H2H	G5H20	480,0	720,0	2160,0	960,0	120,0	3,01	710	17,0	23,3	6,8	1920	0,80
G 5H2X	G5H20	530,0	795,0	2385,0	1060,0	132,5	3,01	710	14,2	23,3	8,5	2385	0,90
G 5HPS	G5HPO	400,0	600,0	1800,0	800,0	140,0	2,95	710	7,2	10,7	36,6	10000	0,80
G 5HPM	G5HPO	440,0	660,0	1980,0	880,0	154,0	2,95	710	6,3	10,7	43,4	11880	0,90
G 5HPH	G5HPO	480,0	720,0	2160,0	960,0	168,0	2,95	710	5,5	10,7	50,9	13920	1,00
G 5HPX	G5HPO	530,0	795,0	2385,0	1060,0	185,5	2,95	710	4,8	10,7	60,1	16430	1,10

Siehe Erläuterung der Technischen Daten. Andere Steifigkeiten auf Anfrage.

- 1) Der Betriebszustand der Anlage kann eine Korrektur der gegebenen Werte notwendig machen.
- 2) Materialbedingte Toleranzen von +/-15 % möglich.

See Explanation of the Technical Data. Different stiffnesses on request.

- 1) The operating state of the system can make it necessary to correct the values given.
- 2) Material caused tolerances of +/-15 % possible



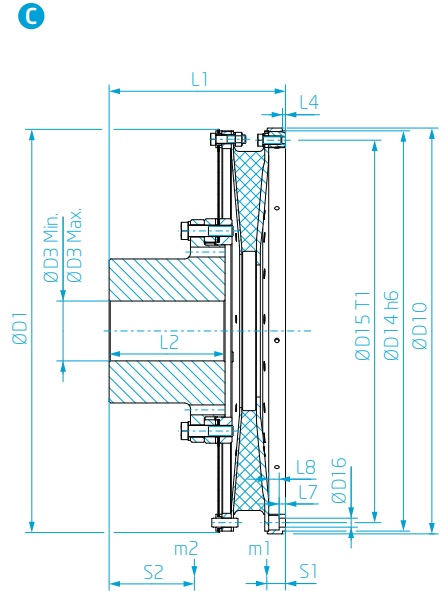
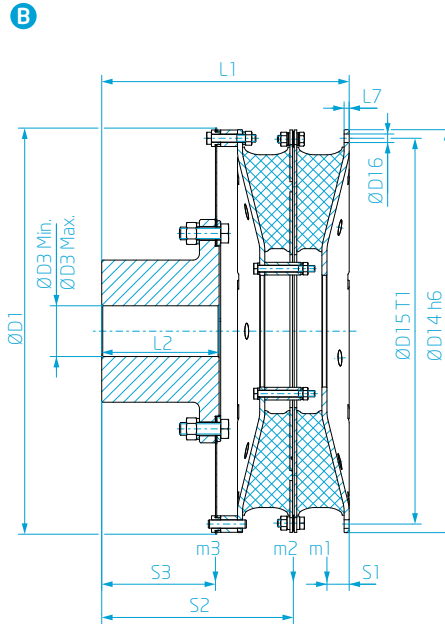
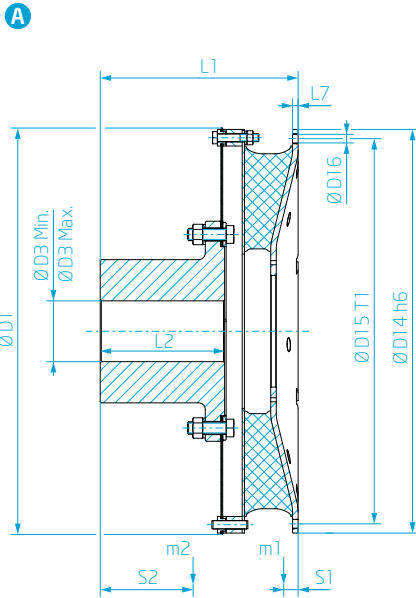

GEOMETRISCHE DATEN GEOMETRIC DATA

Baugruppe Dimension Group	Abbildung Figure	Abmessungen Dimension												
		D ₁ [mm]	D ₃ [mm] Min. Max.		D ₁₀ [mm]	D ₁₄ [mm]	D ₁₅ [mm]	T ₁ [-] Teilung / holes	D ₁₆ [mm]	L ₁ [mm]	L ₂ [mm]	L ₄ [mm]	L ₇ [mm]	L ₈ [mm]
G 2D10	A	685,0	110,0	170,0	-	680,0	650,0	32	15,5	315,5	195,0	-	10,0	-
G 2D20	B	685,0	110,0	170,0	-	680,0	650,0	32	15,5	411,0	195,0	-	10,0	-
G 2F10	A	735,0	110,0	185,0	-	730,0	700,0	32	15,5	357,9	225,0	-	10,0	-
G 2F20	B	735,0	110,0	185,0	-	730,0	700,0	32	15,5	463,0	225,0	-	10,0	-
G 2G10	A	793,0	100,0	200,0	-	790,0	755,0	32	17,5	376,0	235,0	-	10,0	-
G 2G20	B	793,0	100,0	200,0	-	790,0	755,0	32	17,5	488,0	235,0	-	10,0	-
G 3B10	A	925,0	115,0	235,0	-	920,0	880,0	32	20,0	452,2	285,0	-	12,0	-
G 3B20	B	925,0	115,0	235,0	-	920,0	880,0	32	20,0	586,0	285,0	-	12,0	-
G 3C10	E	1000,0	150,0	255,0	-	995,0	950,0	32	22,0	497,5	300,0	-	12,5	-
G 3C20	F	1000,0	150,0	255,0	-	995,0	950,0	32	22,0	656,0	300,0	-	12,5	-
G 3E10	C	1085,0	160,0	275,0	1085,0	1070,0	1025,0	32	24,0	471,7	310,0	8,0	17,0	28,0
G 3E20	D	1085,0	160,0	275,0	1085,0	1070,0	1025,0	32	24,0	574,7	310,0	8,0	17,0	28,0
G 4A10	E	1250,0	200,0	320,0	-	1240,0	1190,0	32	26,0	626,0	385,0	-	14,0	-
G 4A20	F	1250,0	200,0	320,0	-	1240,0	1190,0	32	26,0	821,5	385,0	-	14,0	-

D

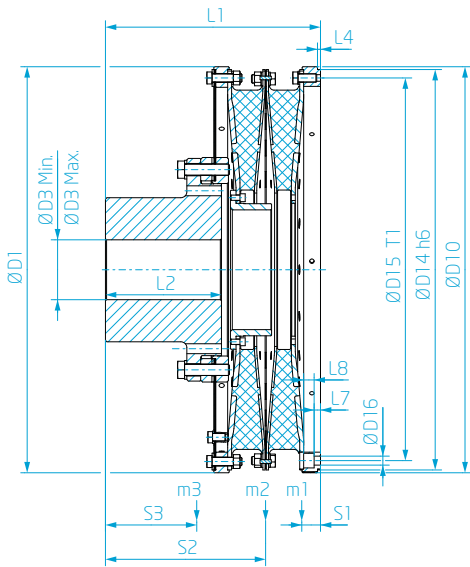

E

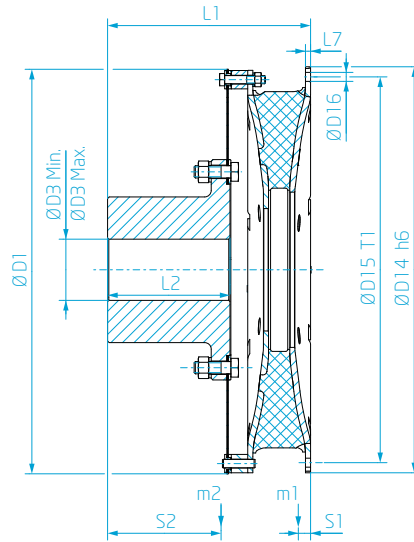

F

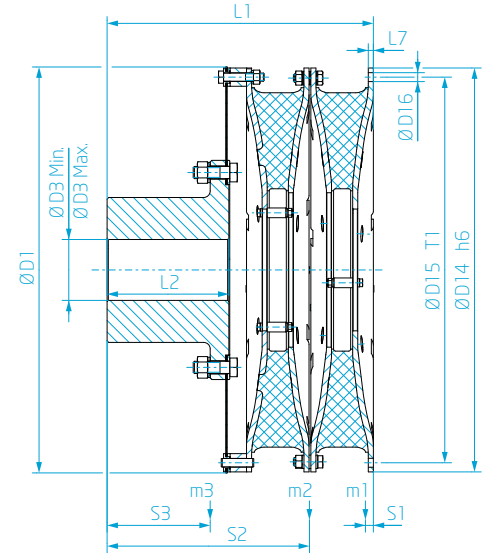

Massenträgheitsmomente
Mass moments of inertia

Masse
Mass

Schwerpunktsabstand
Distance to center of gravity

Anmerkungen
Notes

J_1	J_2	J_3	m_1	m_2	m_3	S_1	S_2	S_3
[kgm ²]	[kgm ²]	[kgm ²]	[kg]	[kg]	[kg]	[mm]	[mm]	[mm]
2,0	3,3	-	33,3	105,1	-	24,5	149,0	-
2,0	2,5	4,4	33,3	37,7	123,0	24,5	317,0	166,0
2,8	4,9	-	398	142,0	-	25,0	168,0	-
2,8	3,4	6,2	398	46,0	162,1	25,0	360,0	185,0
3,9	7,2	-	47,4	182,2	-	28,0	174,0	-
3,9	4,8	9,1	47,4	55,2	206,6	28,0	378,0	191,0
8,5	15,5	-	77,0	295,0	-	34,0	209,0	-
8,5	10,6	19,5	77,0	91,0	332,0	34,0	454,0	228,0
12,9	29,1	-	96,0	403,0	-	30,0	243,0	-
12,9	28,3	29,1	100,0	203,0	404,0	31,0	500,0	243,0
29,2	41,8	-	150,5	504,0	-	50,0	230,0	-
29,2	21,3	48,2	150,5	127,0	564,0	50,0	428,0	244,0
35,0	80,0	-	172,0	743,0	-	37,0	302,0	-
35,0	76,0	80,0	172,0	350,0	749,0	37,0	628,0	303,0

Alle Massen, Schwerpunkte und Massenträgheitsmomente beziehen sich auf min. hub diameter.

All masses, focal points and mass moments of inertia refer to min. hub diameter.



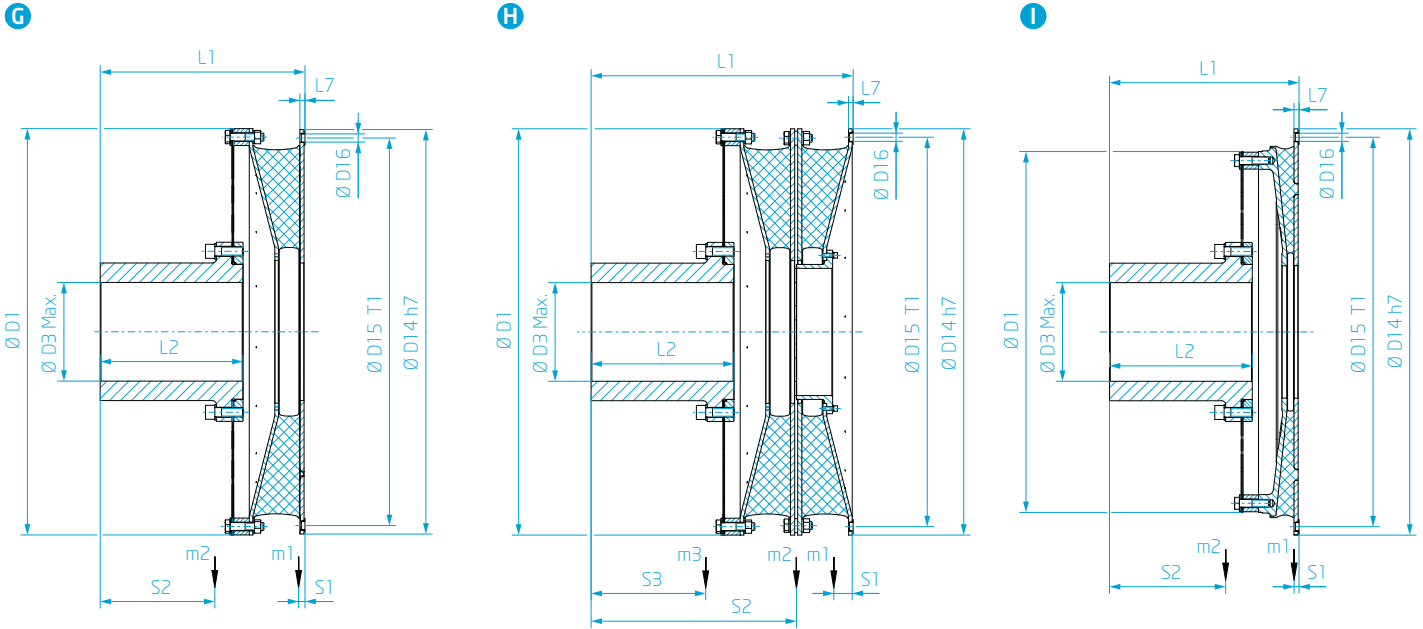

GEOMETRISCHE DATEN GEOMETRIC DATA

Baugruppe Dimension Group	Abbildung Figure	Abmessungen Dimension								
		D ₁ [mm]	D ₃ [mm]	D ₁₄ [mm]	D ₁₅ [mm]	T ₁ [-] <small>Teilung / holes</small>	D ₁₆ [mm]	L ₁ [mm]	L ₂ [mm]	L ₇ [mm]
G 4E10	G	1355,0	330,0	1355,0	1295,0	32	28,6	601,9	385,0	16,5
G 4E20	H	1355,0	330,0	1355,0	1295,0	32	28,6	796,9	385,0	14,5
G 4EPO	I	1204,0	330,0	1355,0	1295,0	32	28,6	547,2	385,0	16,5
G 5B10	G	1565,0	380,0	1565,0	1500,0	32	31,6	788,8	550,0	19,5
G 5B20	H	1565,0	380,0	1565,0	1500,0	32	31,6	1009,3	550,0	17,5
G 5BPO	I	1390,0	380,0	1565,0	1500,0	32	31,6	730,2	550,0	19,5
G 5H10	G	1745,0	420,0	1738,0	1675,0	32	34,6	849,1	570,0	19,5
G 5H20	H	1745,0	420,0	1738,0	1675,0	32	34,6	1091,6	570,0	19,5
G 5HPO	I	1543,0	420,0	1738,0	1675,0	32	34,6	773,8	570,0	20,5

Massenträgheitsmomente Mass moments of inertia			Masse Mass			Schwerpunktsabstand Distance to center of gravity			Anmerkungen Notes
J_1	J_2	J_3	m_1	m_2	m_3	S_1	S_2	S_3	
[kgm ²]	[kgm ²]	[kgm ²]	[kg]	[kg]	[kg]	[mm]	[mm]	[mm]	
50,0	102,0	-	200,0	635,0	-	22,0	323,0	-	<p>Alle Massen, Schwerpunkte und Massenträgheitsmomente beziehen sich auf min. Nabendurchmesser.</p> <p>All masses, focal points and mass moments of inertia refer to min. hub diameter.</p>
47,0	112,0	102,0	210,0	428,0	635,0	62,0	604,0	323,0	
41,0	100,0	-	163,0	652,0	-	12,0	329,0	-	
102,0	203,0	-	303,0	1033,0	-	25,0	439,0	-	
96,0	225,0	203,0	321,0	644,0	1033,0	71,0	790,0	439,0	
83,0	200,0	-	248,0	1061,0	-	15,0	447,0	-	
161,0	361,0	-	389,0	1442,0	-	28,0	467,0	-	
165,0	354,0	361,0	441,0	824,0	1442,0	77,0	851,0	467,0	
129,0	336,0	-	313,0	1451,0	-	16,0	468,0	-	



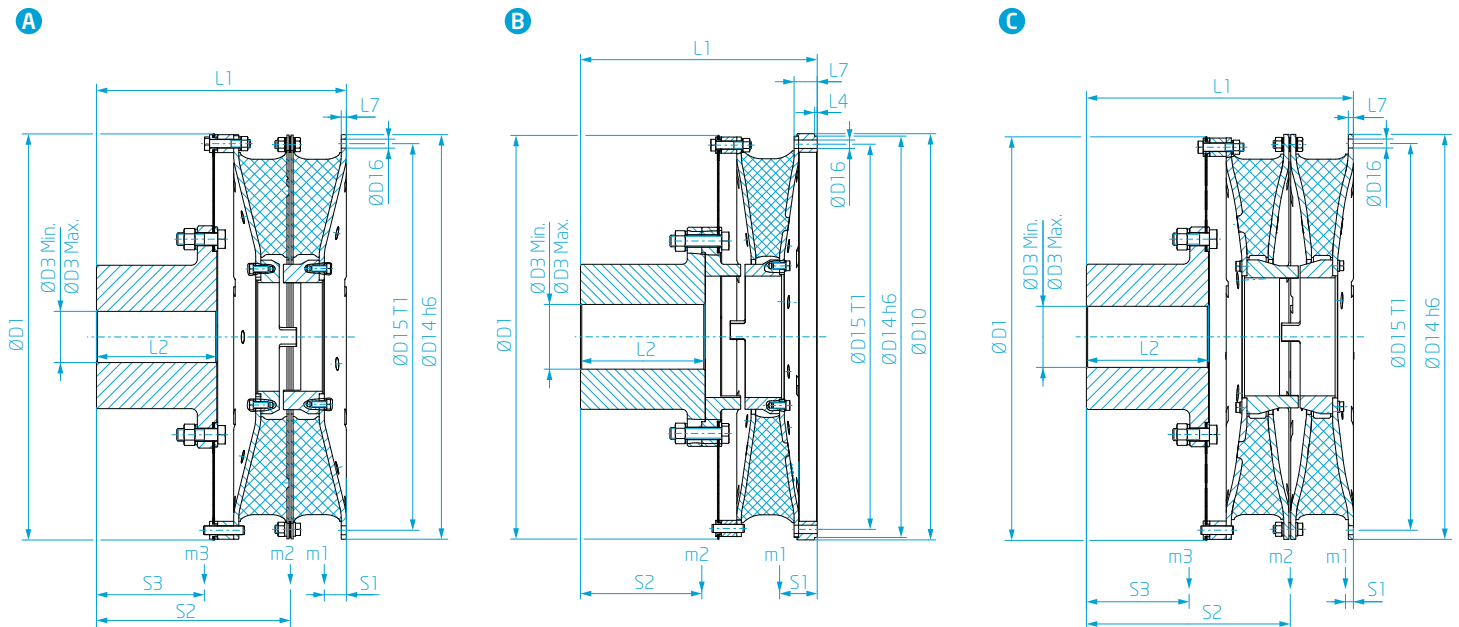

GEOMETRISCHE DATEN GEOMETRIC DATA

Baugruppe Dimension Group	Abbildung Figure	Abmessungen Dimension												
		D ₁ [mm]	D ₃ [mm] Min. Max.		D ₁₀ [mm]	D ₁₄ [mm]	D ₁₅ [mm]	T ₁ [-] Teilung / holes	D ₁₆ [mm]	L ₁ [mm]	L ₂ [mm]	L ₄ [mm]	L ₇ [mm]	L ₈ [mm]
G 2D10	D	685,0	110,0	170,0	690,0	680,0	650,0	32	15,5	337,5	195,0	6,0	37,0	-
G 2D20	A	685,0	110,0	170,0	-	680,0	650,0	32	15,5	411,0	195,0	-	10,0	-
G 2F10	D	735,0	110,0	185,0	740,0	730,0	700,0	32	15,5	406,9	225,0	6,0	37,0	-
G 2F20	A	735,0	110,0	185,0	-	730,0	700,0	32	15,5	463,0	225,0	-	10,0	-
G 2G10	D	793,0	100,0	200,0	800,0	790,0	755,0	32	17,5	438,0	235,0	6,0	42,0	-
G 2G20	A	793,0	100,0	200,0	-	790,0	755,0	32	17,5	488,0	235,0	-	10,0	-
G 3B10	D	925,0	115,0	235,0	935,0	920,0	880,0	32	20,0	520,2	285,0	8,0	48,0	-
G 3B20	A	925,0	115,0	235,0	-	920,0	880,0	32	20,0	586,0	285,0	-	12,0	-
G 3C10	B	1000,0	150,0	255,0	1010,0	995,0	950,0	32	22,0	563,5	300,0	8,0	46,5	-
G 3C20	C	1000,0	150,0	255,0	-	995,0	950,0	32	22,0	656,0	300,0	-	12,5	-
G 3E10					auf Anfrage / on request									
G 3E20	E	1085,0	160,0	275,0	1085,0	1070,0	1025,0	32	24,0	574,7	310,0	8,0	17,0	28,0
G 4A10	B	1250,0	200,0	320,0	1255,0	1240,0	1190,0	32	26,0	732,0	385,0	8,0	72,0	-
G 4A20	C	1250,0	200,0	320,0	-	1240,0	1190,0	32	26,0	821,5	385,0	-	14,0	-

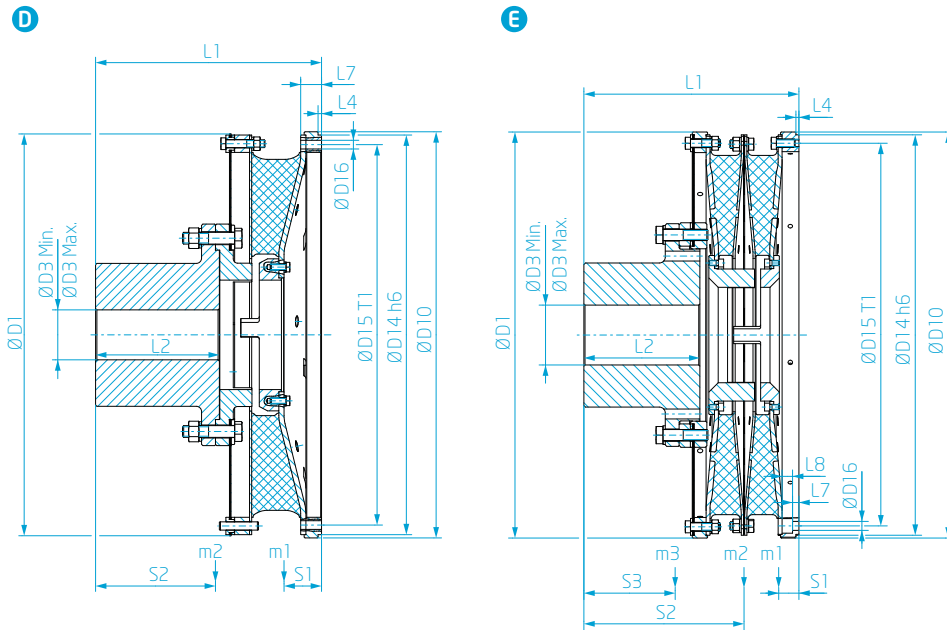

Massenträgheitsmomente Mass moments of inertia			Masse Mass			Schwerpunktsabstand Distance to center of gravity			Anmerkungen Notes
J_1	J_2	J_3	m_1	m_2	m_3	S_1	S_2	S_3	
[kgm ²]	[kgm ²]	[kgm ²]	[kg]	[kg]	[kg]	[mm]	[mm]	[mm]	
4,6	5,7	-	62,0	163,0	-	26,0	167,0	-	Alle Massen, Schwerpunkte und Massenträgheitsmomente beziehen sich auf min. Nabdurchmesser. Werte für die Größen 4E / 5B / 5H auf Anfrage.
2,1	2,5	4,4	39,6	37,7	128,8	30,0	317,0	172,0	
4,7	5,4	-	63,8	162,7	-	23,3	184,7	-	
2,9	3,4	6,3	49,0	46,0	170,0	34,0	360,0	191,0	
7,2	7,9	-	80,7	209,2	-	55,0	191,0	-	
4,1	4,8	9,3	60,0	55,2	216,0	38,0	378,0	197,0	
15,6	17,0	-	129,0	335,0	-	64,0	228,0	-	
9,0	10,6	19,9	95,2	91,0	348,5	43,0	454,0	236,0	
22,5	31,0	-	166,0	441,0	-	63,0	260,0	-	
13,8	28,1	30,0	128,0	202,0	432,0	43,0	500,0	255,0	
auf Anfrage / on request									
29,9	21,3	48,2	175,0	127,0	567,0	54,0	428,0	244,0	All masses, focal points and mass moments of inertia refer to min. hub diameter. Values for sizes 4E / 5B / 5H on request.
69,0	87,0	-	308,0	839,0	-	86,0	329,0	-	
37,6	76,6	82,2	222,0	351,0	799,0	53,0	628,0	318,0	



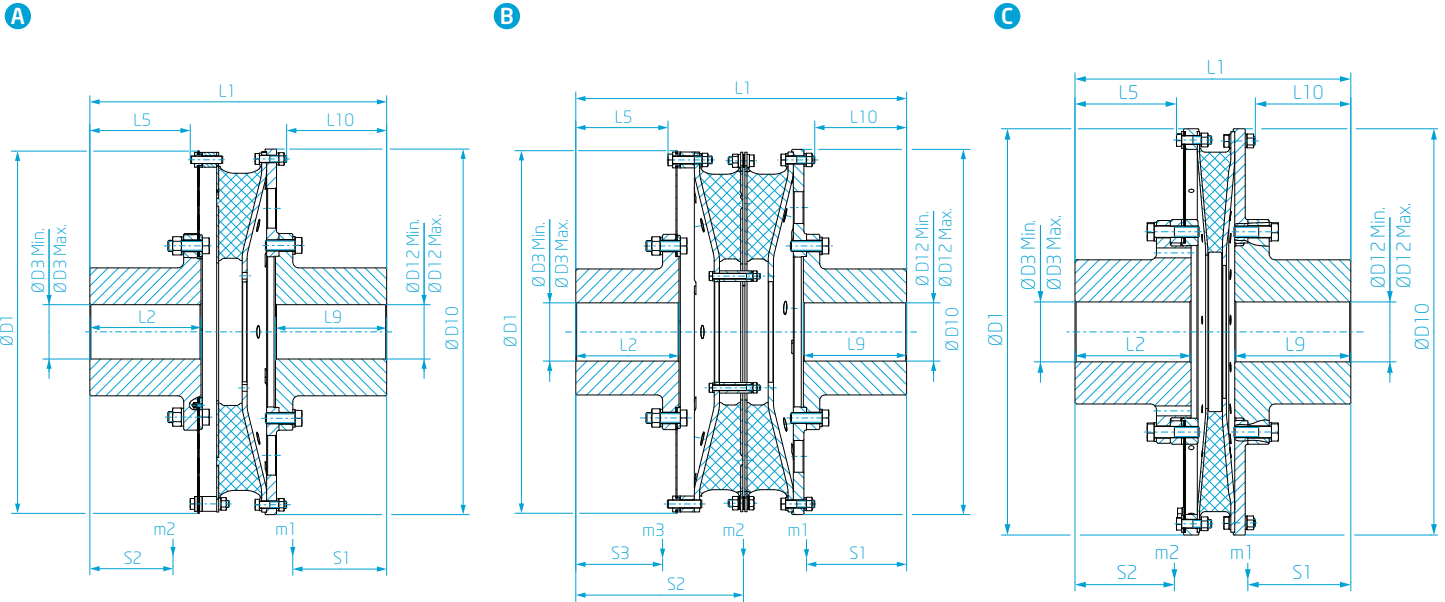

GEOMETRISCHE DATEN GEOMETRIC DATA

Baugruppe Dimension Group	Abbildung Figure	Abmessungen Dimension										
		D ₁ [mm]	D ₃ [mm] Min. Max.		D ₁₀ [mm]	D ₁₂ [mm] Min. Max.		L ₁ [mm]	L ₂ [mm]	L ₅ [mm]	L ₉ [mm]	L ₁₀ [mm]
G 2D10	A	685,0	110,0	170,0	690,0	110,0	170,0	529,5	195,0	174,2	195,0	173,5
G 2D20	B	685,0	110,0	170,0	690,0	110,0	170,0	625,0	195,0	174,2	195,0	173,5
G 2F10	A	735,0	110,0	185,0	740,0	110,0	185,0	600,9	225,0	203,2	225,0	202,5
G 2F20	B	735,0	110,0	185,0	740,0	110,0	185,0	706,0	225,0	203,2	225,0	202,5
G 2G10	A	793,0	100,0	200,0	800,0	100,0	200,0	633,0	235,0	211,0	235,0	211,5
G 2G20	B	793,0	100,0	200,0	800,0	100,0	200,0	745,0	235,0	211,0	235,0	211,5
G 3B10	A	925,0	115,0	235,0	935,0	115,0	235,0	758,2	285,0	256,5	285,0	252,5
G 3B20	B	925,0	115,0	235,0	935,0	115,0	235,0	892,0	285,0	256,5	285,0	252,5
G 3C10	E	1000,0	150,0	255,0	1010,0	150,0	255,0	824,5	300,0	274,5	300,0	264,0
G 3C20	F	1000,0	150,0	255,0	1010,0	150,0	255,0	983,0	300,0	274,5	300,0	264,0
G 3E10	C	1085,0	160,0	275,0	1085,0	160,0	275,0	736,7	310,0	271,0	310,0	255,0
G 3E20	D	1085,0	160,0	275,0	1085,0	160,0	275,0	839,7	310,0	271,0	310,0	255,0
G 4A10	E	1250,0	200,0	320,0	1255,0	200,0	320,0	1041,0	385,0	355,0	385,0	348,5
G 4A20	F	1250,0	200,0	320,0	1255,0	200,0	320,0	1236,5	385,0	355,0	385,0	348,5

RATO R+

ERLÄUTERUNGEN DES PRODUKT-CODES EXPLANATIONS OF THE PRODUCT CODE

Alle VULKAN Couplings Produkte sind mit einem Produktcode gekennzeichnet. Dieser Code setzt sich aus verschiedenen Parameter-Angaben zusammen und ermöglicht es, unsere Produkte eindeutig zu identifizieren.

All VULKAN Couplings products are identified by a product code. This code consists of several parameters and it enables the clear identification of all products.

PRODUKT-CODE BEISPIEL RATO R+

Hier haben wir den Code am Beispiel einer RATO R+ (G 3B1M), Größe 3B, 1-reihig, Elementsteifigkeit M, Baureihe 2200 entschlüsselt dargestellt.

LEISTUNGSDATEN PERFORMANCE DATA			
Kupplungstyp Type of Coupling		T_{KN}	T_{Kmax1}
		[kNm]	[kNm]
Größe Size	Baugruppe Dimension Group	Nenn-dreh-moment Nominal Torque	Max. Drehmoment ₁ Max. Torque ₁
G 3B1M	G 3B10	70,00	105,00

PRODUCT CODE EXAMPLE RATO R+

We have decoded here the product code of a RATO R+ (G 3B1M), Size 3B, 1 row, Element stiffness M, Series 2200.

Auszug aus den Leistungsdaten. Für vollständige Daten siehe Seite 08 ff.
Excerpt from performance data. Complete data see page 08 ff.

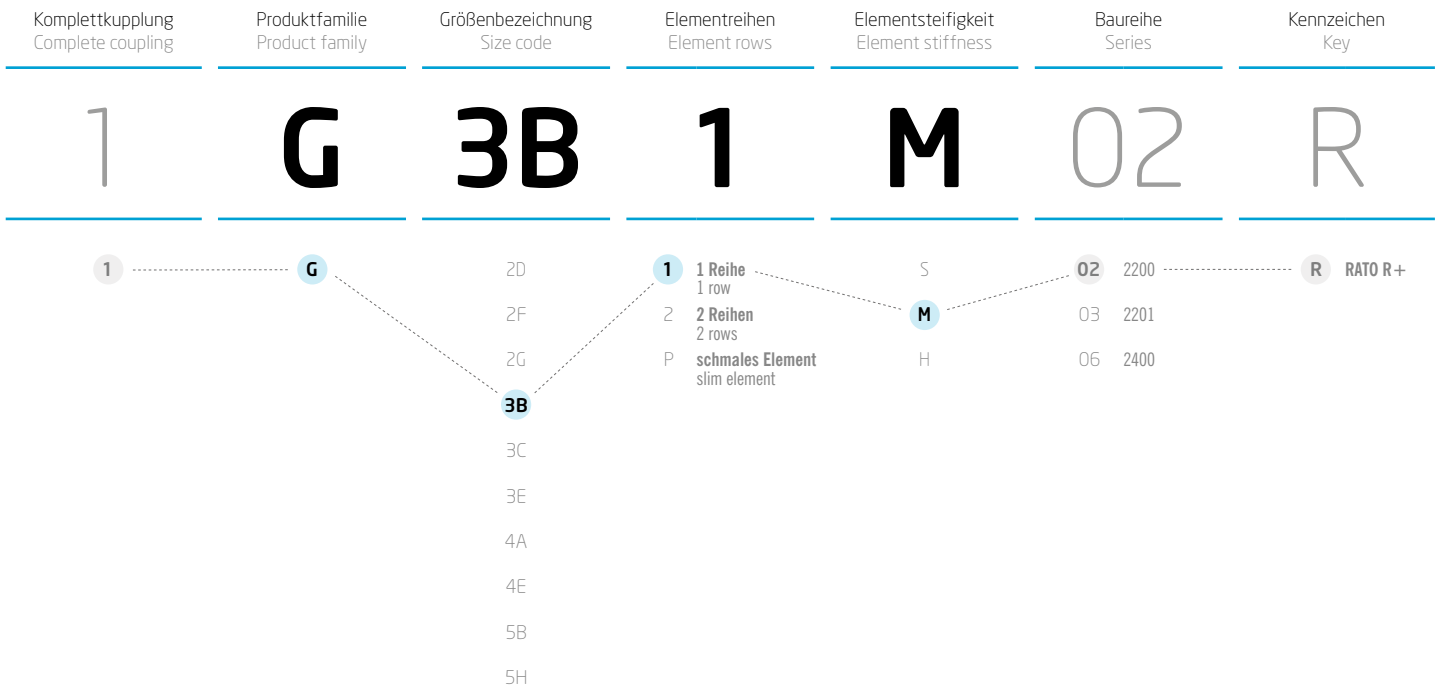

NOTIZEN NOTICE

The image shows a technical drawing grid. The grid is composed of small squares, each containing a diagonal cross. A central rectangular area is defined by a double-line border and contains four horizontal lines for writing. On the right side, there is a vertical scale from 0 to 220 with tick marks every 10 units.

RATO R

NOTIZEN NOTICE

The drawing area is a grid of squares, each divided into four triangles by a diagonal line. A central rectangular area is defined by four horizontal lines, intended for handwritten notes. The grid extends to the right edge of the page, where a vertical scale is marked from 0 to 220 in increments of 10.

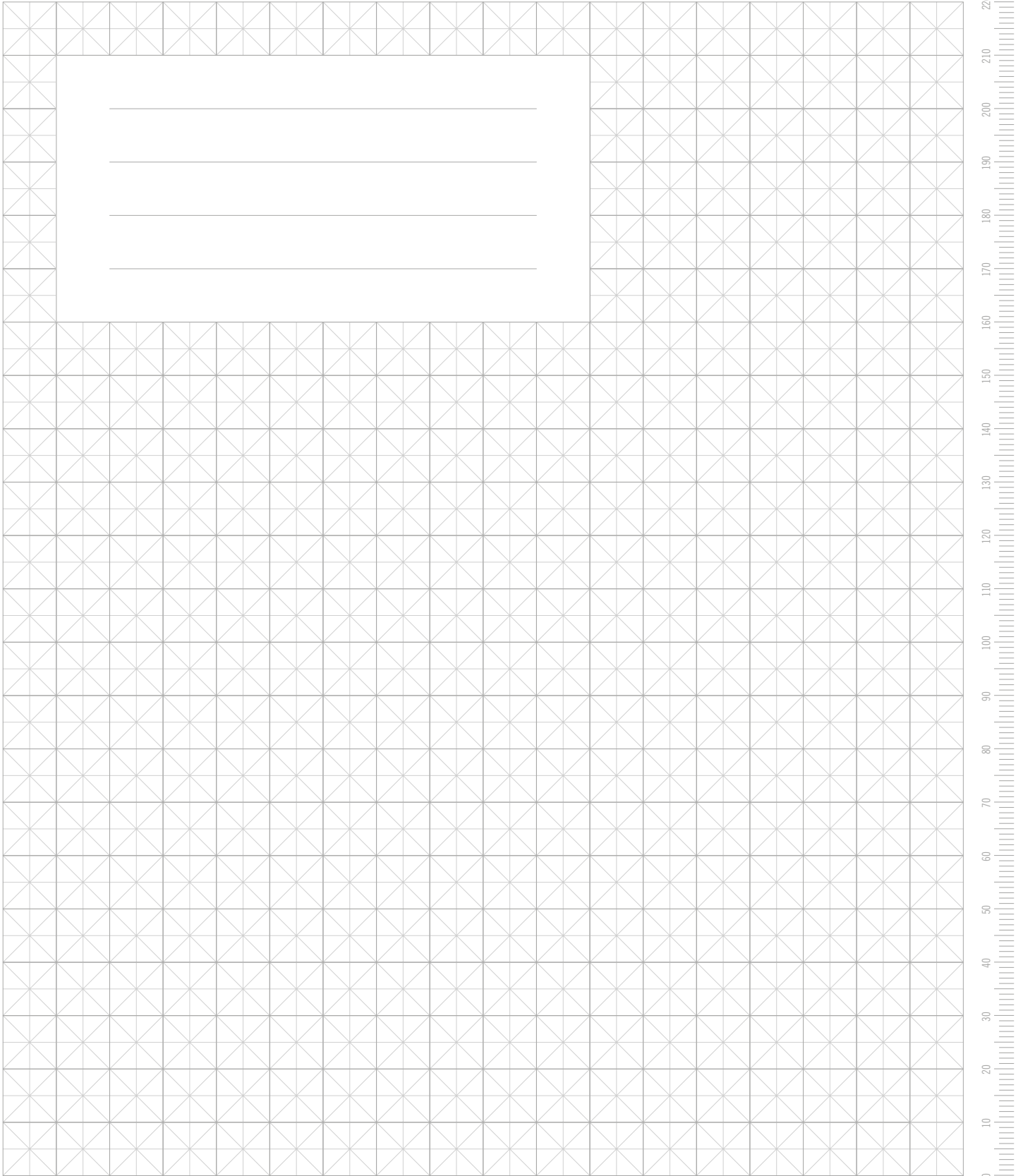

ONLINE-SERVICE

WEITERE INFORMATIONEN FINDEN SIE AUF WWW.VULKAN.COM FOR FURTHER INFORMATION, PLEASE REFER TO OUR WEBSITE WWW.VULKAN.COM

RATO R+

www.vulkan.com/de-de/couplings/produkte/hochelastische-kupplungen/rato-r+



RATO R+

www.vulkan.com/en-us/couplings/products/highly-flexible-couplings/rato-r+

KATALOGE & BROSCHÜREN

www.vulkan.com/de-de/couplings/downloads-videos



CATALOGUES & BROCHURES

www.vulkan.com/en-us/couplings/downloads-videos

VULKAN ENGINEERING PORTAL

www.vulkan.com/de-de/couplings/service/vulkan-engineering-portal



VULKAN ENGINEERING PORTAL

www.vulkan.com/en-us/couplings/service/vulkan-engineering-portal

PRODUKTSELEKTOR

www.vulkan.com/de-de/couplings/service/produktselektor



PRODUCT SELECTOR

www.vulkan.com/en-us/couplings/service/product-selector

AUTORISIERTE HÄNDLER

www.vulkan.com/de-de/couplings/kontakt



AUTHORISED DISTRIBUTORS

www.vulkan.com/en-us/couplings/contact

VIDEOS

www.vulkan.com/de-de/couplings/downloads-videos/videos



VIDEOS

www.vulkan.com/en-us/couplings/downloads-videos/videos

GÜLTIGKEITSKLAUSEL

Die enthaltenen technischen Daten sind nur gültig bei Einsatz in definierten Anwendungsgebieten. Diese umfassen:

- ⌚ Haupt- und Nebenantriebe auf Schiffen
- ⌚ Generatorsätze auf Schiffen
- ⌚ Antriebe für stationäre Energieerzeugung mit Diesel- oder Gasmotoren

Abweichende Anwendungen bedürfen einer individuellen Betrachtung. Bitte kontaktieren Sie hierzu ihren lokalen VULKAN Vertreter.

Die vorliegende Broschüre ersetzt alle vorherigen Ausgaben, ältere Drucke verlieren ihre Gültigkeit. VULKAN ist berechtigt, aufgrund neuerer Entwicklungen die in dieser Broschüre enthaltenen Daten entsprechend anzupassen und zu verändern. Die neuen Daten gelten nur für nach der Änderung bestellte Kupplungen. Es liegt im Verantwortungsbereich des Anwenders dafür zu sorgen, dass ausschließlich die aktuelle Katalogversion verwendet wird. Der jeweils aktuelle Stand ist auf der Webseite von VULKAN unter www.vulkan.com jederzeit abrufbar.

Die Angaben in dieser Broschüre beziehen sich auf den technischen Standard gültig im Hause VULKAN und stehen unter den in den Erläuterungen definierten Bedingungen. Es liegt allein im Entscheidungs- und Verantwortungsrahmen des Systemverantwortlichen für die Antriebslinie, entsprechende Rückschlüsse auf das Systemverhalten zu ziehen.

VULKAN Drehschwingungsanalysen berücksichtigen in der Regel nur das rein mechanische Schwingungssystem. Als reiner Komponentenhersteller übernimmt VULKAN mit der Analyse des Drehschwingungssystems (stationär, transient) nicht die Systemverantwortung! Die Genauigkeit der Analyse hängt von der Genauigkeit der verwendeten bzw. der VULKAN zur Verfügung gestellten Daten ab.

Änderungen aufgrund des technischen Fortschritts sind vorbehalten. Bei Unklarheiten bzw. Rückfragen kontaktieren Sie bitte VULKAN.

Stand: 07/2019

Das Recht auf Vervielfältigung, Nachdruck und Übersetzungen behalten wir uns vor. Maß- und Konstruktionsänderungen vorbehalten.

VALIDITY CLAUSE

The containing technical data is valid only for defined areas of applications. These includes:

- ⌚ Main propulsion and auxiliary drives on ships
- ⌚ Generator sets on ships
- ⌚ Drives for stationary energy production with diesel or gas engines

For other than the named applications please contact your local VULKAN supplier for further consideration.

The present catalogue shall replace all previous editions, any previous printings shall no longer be valid. Based on new developments, VULKAN reserves the right to amend and change any details contained in this catalogue respectively. The new data shall only apply with respect to couplings that were ordered after said amendment or change. It shall be the responsibility of the user to ensure that only the latest catalogue issue will be used. The respective latest issue can be seen on the website of VULKAN on www.vulkan.com.

The data contained in this catalogue refer to the technical standard as presently used by VULKAN with defined conditions according to the explanations. It shall be the sole responsibility and decision of the system administrator for the drive line to draw conclusions about the system behaviour.

VULKAN torsional vibration analysis usually only consider the pure mechanical mass-elastic system. Being a component manufacturer exclusively, VULKAN assumes no system responsibility with the analysis of the torsional vibration system (stationary, transiently)! The accuracy of the analysis depends on the exactness of the used data and the data VULKAN is provided with, respectively.

Any changes due to the technological progress are reserved. For questions or queries please contact VULKAN.

Status: 07/2019

All duplication, reprinting and translation rights are reserved. We reserve the right to modify dimensions and constructions without prior notice.

PUBLISHER:

VULKAN Couplings

CONCEPT AND DESIGN:

Hackforth Holding GmbH & Co. KG
VULKAN Marketing
Heerstraße 66, 44653 Herne / Germany
E-mail: marketing@vulkan.com

STATUS: 07/2019

All duplication, reprinting and translation rights are reserved. Any changes due to the technological progress are reserved. For questions or queries please contact VULKAN.