

TOYOTA FT86 - SCION FR-S - SUBARU BRZ FIA APPENDIX J COMPLIANT FIA JOINT TYPE ROLLCAGE

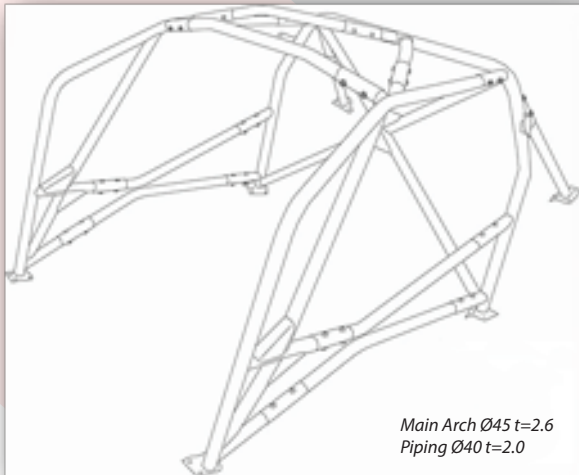

Fabricated in compliance to the FIA Appendix J Article 8 under safety cages, the new joint design enables participation in rally series regulated by the FIA and JAF.



- Removable member (dismountable joints) approved by FIA specifications
- Reinforcement gusset (junction or bend) approved by FIA specifications
- Rollcage mounting foot (base plates) are bolt-in type however may be welded to the bodyshell/chassis in addition to the bolts.
- Main arch (hoop) configured at 45mm OD t=2.6mm, all other piping at 40mm OD t=2.0mm
- Windscreen pillar reinforcement fitted on A pillar to meet with FIA specifications

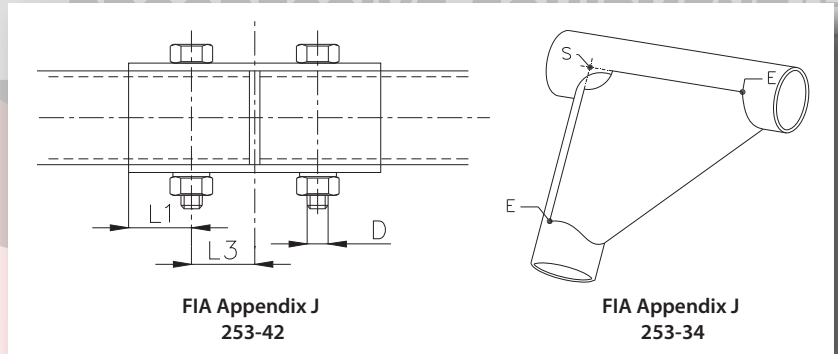

Part Number: 965 295 W
MSRP: \$3,267.00 (USD)

Federation Internationale de l'Automobile. FIA Regulations: Appendix J. Article 253-2013 Safety Equipment (Groups N, A).
By FIA Sport Technical Department. Paris France: FIA Headquarters, November 2012. (Gusset Drawing 253-34).

Federation Internationale de l'Automobile. FIA Regulations: Appendix J. Article 253-2013 Safety Equipment (Groups N, A).
By FIA Sport Technical Department. Paris France: FIA Headquarters, November 2012. (Removable Member Drawing 253-42).



*Proton Satria Neo FIA Joint Rollcage shown



Our objective is to develop your enjoyment of driving through motor sports



CARROSSER Co. Ltd
1664-1 Shinbo-cho Takasaki-shi
Gunma-ken 370-0018 JAPAN

Tel: (+81) 27-352-3578 • Fax: (+81) 27-352-1919
<http://www.cusco.co.jp>
oversea@cusco.co.jp

CUSCO USA Inc.
16631 Gemini Lane

Huntington Beach, CA 92647 USA
Tel: (714) 907-0033 • Fax: (714) 369-8142
<http://www.cuscousainc.com>
info@cuscosainc.com



*CUSCO PRODUCTS ARE FOR OFFROAD & COMPETITION USE ONLY
*Genuine 100% Made in Japan

