

CUSCO Rear Sway Bar for 2020- Toyota Supra (A90)

[CUSCO Part #] 1C2-311-B22

[Application] **2019- Toyota GR Supra, 3.0L Turbo (A90)**
Compatible Toyota Genuine Part #: 48812-WAA02

[Included] CUSCO Rear Sway bar x1
Bushing x2
Bracket x2
Spacer x2

[Preparation] All bolts and nuts are **NOT reusable**. Please prepare following Toyota Genuine parts **BEFORE** start installing our product.

- 90118-WA289: Nut, Rear Suspension Arm Cover x8 pcs.
- 90118-WA344: Bolt, Rear Shock Absorber Lower x2 pcs.
- 90118-WA197: Nut, Rear Shock Absorber Lower x2 pcs.
- 90118-WA291: Bolt, Rear Lower Arm/Knuckle x2 pcs.
- 90118-WA259: Nut, Rear Lower Arm/Knuckle x2 pcs.
- 90118-WA504: Bolt, Rear Cross Member Brace x8 pcs.
- 90118-WA280: Bolt, Rear Cross Member Assy x4 pcs.
- 90118-WA201: Nut, Rear Sway Bar Linkage x2 pcs.
- 90118-WA343: Bolt, Rear Sway Bar Bracket x4 pcs.

[Instruction]

1. Remove tires from the vehicle
2. Remove #2 under covers

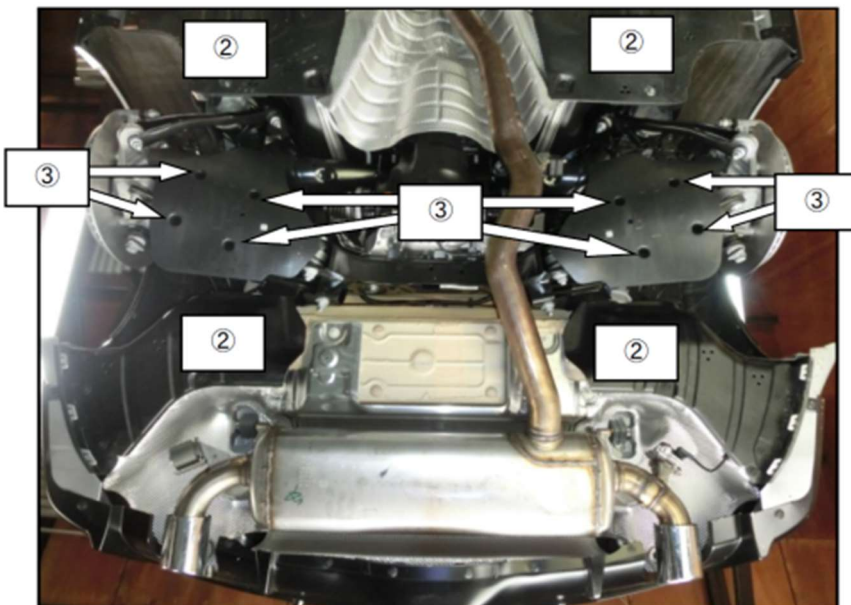

3. Remove #3 Rear Suspension Arm Covers. All removed nuts (x8) are not Re-Usable.

#3 Nut: Toyota Part # 90118-WA289, Torque Spec 6.0 Nm/4.4 ft-lbs.

4. Remove OE Aluminum Brace

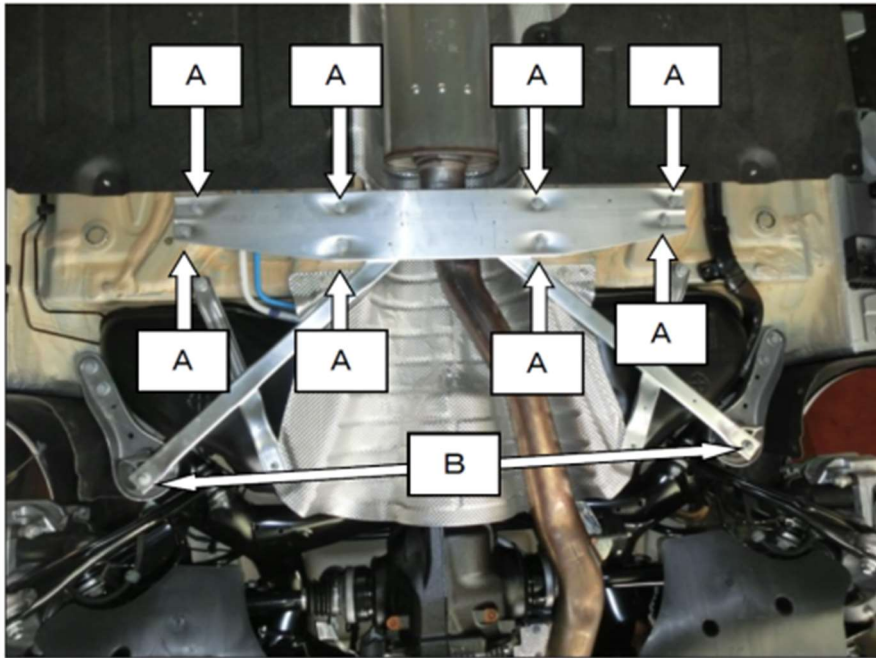

Torque Spec: "A" Bolt (x8): 26 Nm/19 ft-lbs. / "B" Bolt: 56 Nm/41 ft-lbs.

5. Remove Wheel Speed sensors and disconnect the shock damper e-control connectors from rear shock absorbers.

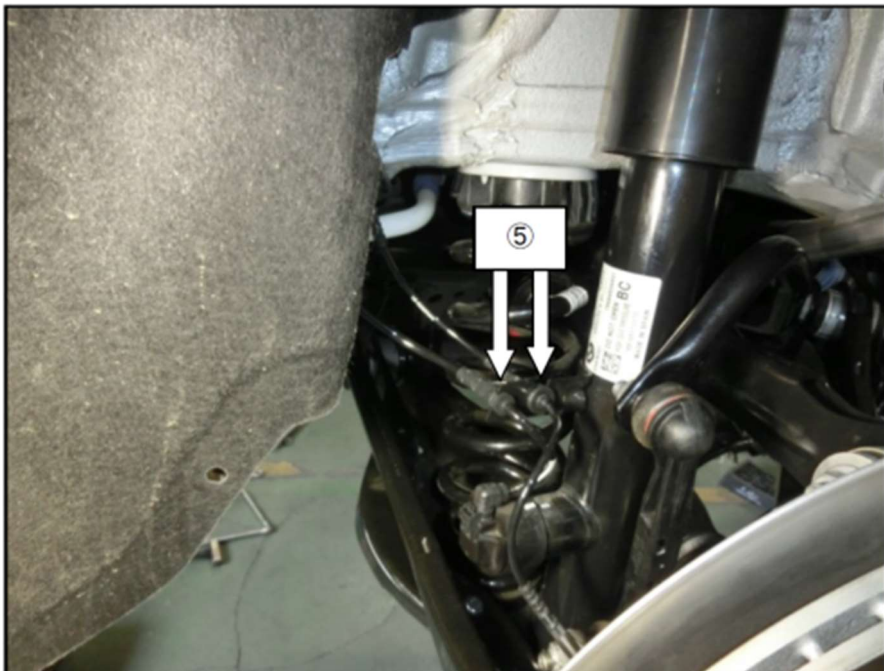

6. Disconnect Ground Wire from the body (#6).
7. Remove bolts and clips and take AFS unit out from rear member (#7).

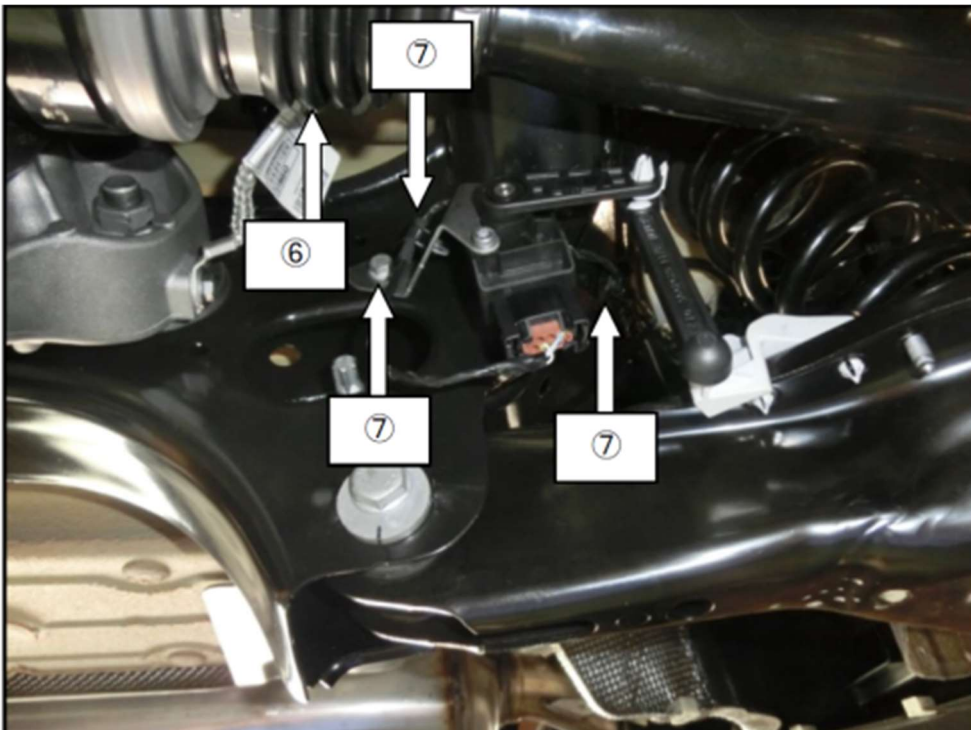

8. Remove x2 harnesses (to Brake Caliper) and hoses (#8) for free moving.

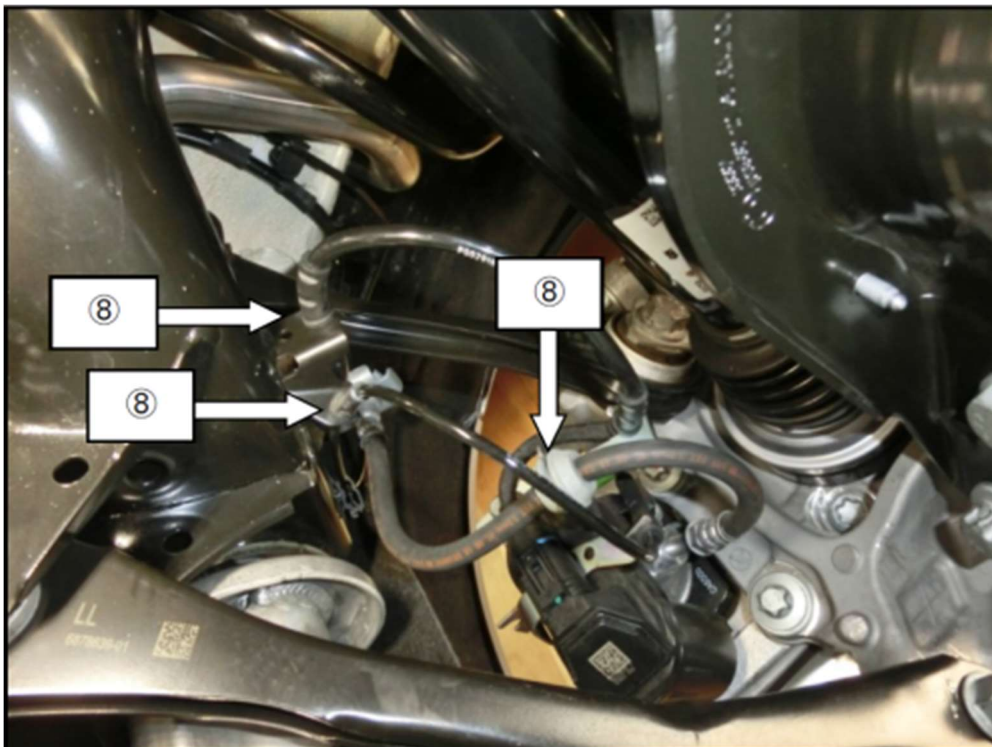

9. Support lower arm by using jack and loosen bolt (A) and (B). Then remove coil spring out from the suspension arm.

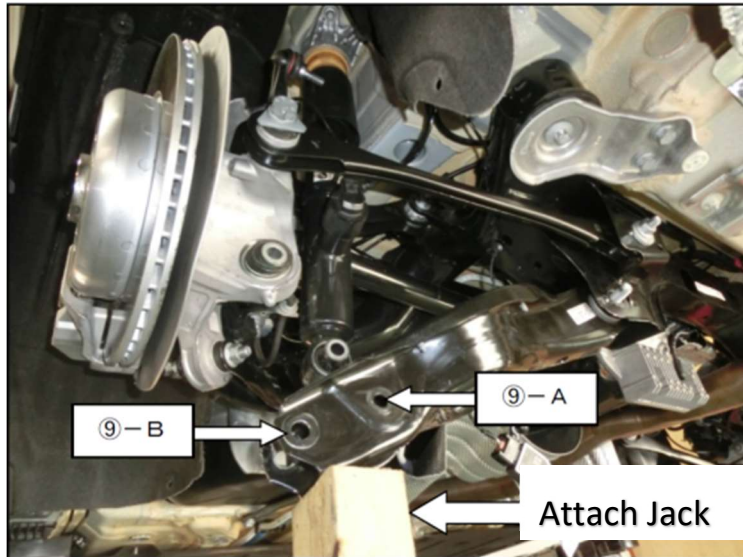

All bolts and nuts cannot be re-used. Please have following bolts and nuts at Toyota Dealer first.

Toyota Genuine Part # Bolt (A): 90118-WA291 x2 pcs.

- Torque Spec: 100 Nm/73 ft-lbs. (+90 deg turn)

Toyota Genuine Part # Nut (B): 90118-WA259 x2 pcs.

- Torque Spec: 165 Nm/121 ft-lbs. (+90 deg turn)

10. Hold exhaust muffler first and remove x3 #10 exhaust rubber muffler hangers. Then Drop approx. 100mm (4 inch) down to make more work space to remove OE sway bar.

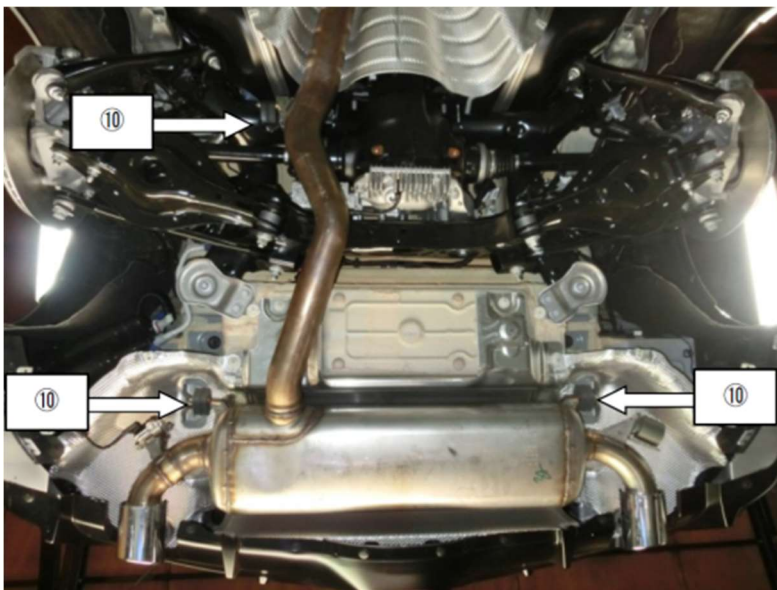

11. MUST hold the rear differential case by jack or proper tool first. Remove x8 #11 Support plates bolts.
12. Remove x4 #12 bolts/plates from Rear Cross Member (Rear sub-frame). Then slowly drop Rear Cross Member (Rear sub-frame) approx. 60mm down by using jack.

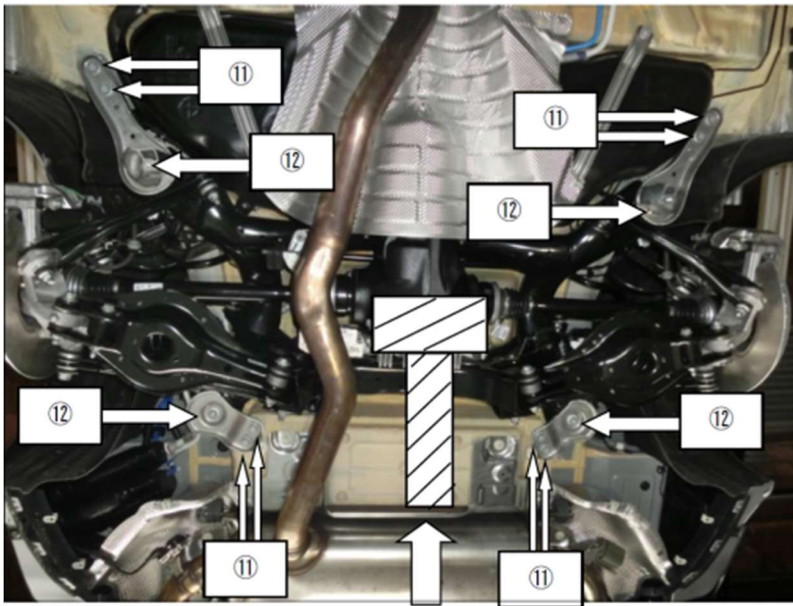

All bolts and nuts cannot be re-used. Please have following bolts and nuts at Toyota Dealer first.

Toyota Genuine Part # Bolt (#11): 90118-WA504 x8 pcs.

- Torque Spec: 47 Nm/34 ft-lbs. +45 deg turn

Toyota Genuine Part # Nut (#12): 90118-WA280 x4 pcs.

- Torque Spec: 108 Nm/79 ft-lbs.

13. Disconnect sway bar Links from OE Sway bar.

All removed nuts cannot be re-used.

Toyota Genuine Part #: 90118-WA201 x2

- Torque Spec: 56 Nm/41 ft-lbs.

14. Remove #14 sway brackets and bushings from the body.

All removed bolts cannot be re-used.

Toyota Genuine Part #: 90118-WA343 x4

- Torque Spec 21.4 Nm/15 ft-lbs.

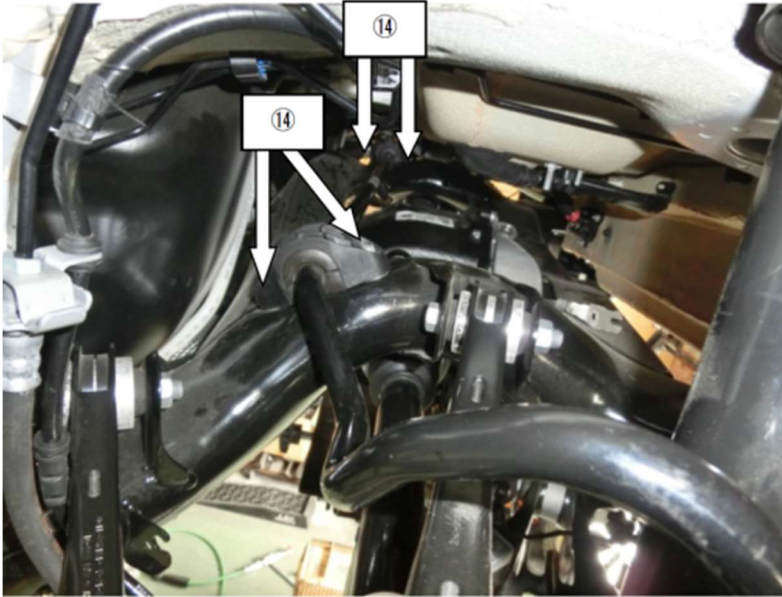

15. Remove OE rear sway bar from side.

16. Set CUSCO rear sway bar as following. Bracket/Bushing/Spacer

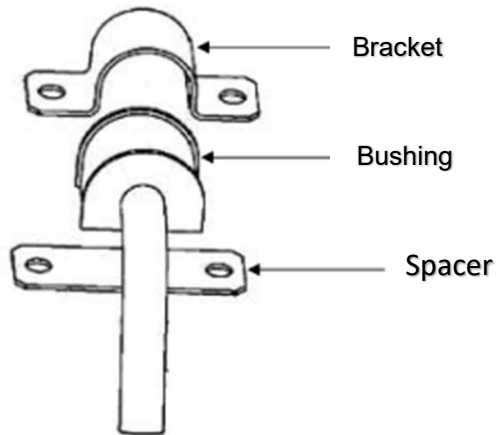

17. Install CUSCO Sway Bar in reverse order of removal.

18. Check if the nuts are loosened periodically.

CUSCO USA Inc.

16635 Gemini Lane, Huntington Beach, CA 92647

Tel: (714) 907-0033, E-Mail: info@cuscouusainc.com

www.cuscousainc.com