

Business Procedure

Guarding of Workshop Equipment Document Number – OHS-PROC-167

This document applies to the following site(s):

Brisbane Office	<input type="checkbox"/>	Meandu Mine	<input type="checkbox"/>	Stanwell PS	<input checked="" type="checkbox"/>
Tarong Site	<input checked="" type="checkbox"/>	Wivenhoe Pipeline	<input checked="" type="checkbox"/>		

Table of Contents

1.0	Purpose.....	3
2.0	Scope	3
3.0	Guarding Preventative Controls.....	3
3.1	Selection Criteria of Guards	3
3.1.1	Risk Assessment	3
3.1.2	The Intended Use of the Machine	3
3.1.3	The Nature and Frequency of Access to the Danger Zone.....	4
3.1.4	Number and Geometry of Hazards	4
3.2	The Hierarchy of Guarding	4
3.3	Types of Guards	5
3.4	Combination of Guards.....	5
3.5	General Requirements	5
3.5.1	Guard Design Requirements	5
3.5.2	General Workshop Requirements	6
3.5.3	Emergency Stop	6
4.0	Inspection and Auditing.....	6
4.1	Periodical / Annual Inspection	7
4.2	Safety Review.....	7
4.3	Pre-start Inspection	7
5.0	Signage and Labelling	7
6.0	Supervision, Information and Training	8
6.1	Supervision	8
6.2	Information.....	8
6.3	Training.....	8
6.4	Recognition of prior learning	9
6.5	Specialised workshop plant.....	9
6.6	Training Records	9
7.0	Operational & Maintenance Documentation.....	9
8.0	Hiring & Purchasing of Workshop Plant & Equipment.....	9
9.0	Responsibilities	9

WRITTEN BY: L. Lucke

ENDORSED/CHECKED BY: T. Hoare

APPROVED BY: L. Lucke

Guarding of Workshop Equipment

9.1	Site Manager	9
9.2	Managers / Superintendents (Workshop owners).....	9
9.3	Workshop Plant and Equipment Operator.....	9
9.4	Workshop Responsible Person	10
10.0	Review, Consultation and Communication	10
11.0	References.....	10
12.0	Definitions	11
13.0	Revision History	11
14.0	Appendices	12
14.1	Appendix A – Mechanical Hazards of Workshop Machinery	12
14.1.1	Drawing-in or Trapping Hazards	12
14.1.2	Entanglement Hazard.....	13
14.1.3	Shearing Hazards.....	13
14.1.4	Cutting Hazards.....	14
14.1.5	Impact Hazards	14
14.1.6	Stabbing and Puncturing Hazards.....	15
14.1.7	Crushing Hazards.....	15
14.1.8	Friction Abrasion Hazards	15
14.1.9	Other Hazards	15
14.2	Appendix B – Types of Guards	16
14.2.1	Permanently Fixed Physical Barrier	16
14.2.2	Securely Fixed Physical Barrier (Fixed Guard)	16
14.2.3	Distance Guard.....	16
14.2.4	Interlocking Physical Barriers (Control Guard).....	16
14.2.5	Presence Sensing Equipment	17
14.2.6	Self-Closing Guards	18
14.2.7	Two-Hand Control Device	19
14.3	Appendix C Emergency Stop Push buttons	19
14.4	Appendix D Machine Inspection Checklist	20
14.5	Appendix E Machine Safety Review Tool	21

Guarding of Workshop Equipment

1.0 Purpose

The purpose of this document is to define the Stanwell requirements for the guarding of plant, equipment and machinery and the personnel who interact with them.

It is intended that this document form the central point of reference for all key aspects of machine guarding and reference will be made to Australian Standards, Procedures and Specifications where additional and more detailed information is required.

2.0 Scope

This document will apply to all Stanwell controlled operations. It covers the minimum requirements for the selection, technical design, construction, installation, operation and maintenance of machine guarding of workshop plant and equipment at sites owned and operated by Stanwell Corporation Limited.

The information contained in this document is intended to assist personnel identify and control hazards encountered at Stanwell operations, there may be additional hazards and subsequent risks at your site which have not been specifically addressed. You are still required under State Legislation to identify and assess these risks and ensure that appropriate control measures are implemented and reviewed to prevent or minimise exposure to these risks.

3.0 Guarding Preventative Controls

The use of complementary guards (guarding and protective devices) is required where a machine's inherently safe design does not sufficiently minimize the risks resulting from machinery to the health and safety of workers and others.

Guarding depending on the application can either be considered isolation and/or an engineering control (eg. distance guard will be considered isolation whilst a presence sensing device may be considered an engineering control).

The introduction of and any modifications to workshop plant and equipment and associated guarding should be managed through the Plant Modification Request (PMR) process and should comply with the requirements of this procedure, the relevant legislation and Australian Standards.

3.1 Selection Criteria of Guards

Where the plant or equipment risk assessment has established a requirement for guards they shall be selected based on the following criteria:

3.1.1 Risk Assessment

In all instances the exact choice of guarding for a particular machine must be made based on the outcome of the risk assessment for that particular machine and the hazards present. For the detailed list of machine hazards see **Appendix A**.

For example, a fixed mesh guard may be very effective for controlling mechanical hazards such as drawing-in when located at a sufficient distance from the hazard zone, however this type of guarding presents very little protection against hazards such as noise, radiation and hazardous substances.

3.1.2 The Intended Use of the Machine

The selection of an appropriate safeguarding device must be based on the intended use of the machine. That is the use for which the machine is suited according to the information provided by the manufacturer or which is deemed usual according to its design, construction and function.

Guarding of Workshop Equipment

3.1.3 The Nature and Frequency of Access to the Danger Zone

When guarding is used as a measure to control risk in relation to plant or equipment, the hierarchy of guarding is applied.

3.1.4 Number and Geometry of Hazards

When selecting guards the following should be taken into account: the dimensions of the line of fire area, the angle and energy of projectiles, the relative position of personnel from the source of the hazard and the reaching distances with different part of body.

3.2 The Hierarchy of Guarding

The hierarchy to be used for the selection of new or modified guards is outlined below:

- If a person would not need either complete or partial access to the dangerous area during normal operation, maintenance or cleaning of the plant, the guarding is to be a **permanently fixed physical barrier**;
- If a person may require complete or partial access to the dangerous area during normal operation, maintenance or cleaning of the plant, the guarding is to be an **interlocked physical barrier**. The interlocked physical barrier allows access to the area being guarded at times when that area does not present a risk and prevents access to that area at any other time;
- If it is not reasonably practicable to use a permanently fixed physical barrier or an interlocked physical barrier, the guarding used is to be a **physical barrier securely fixed** in position by means of fasteners or other suitable devices sufficient to ensure that the guard cannot be altered or removed without the aid of a tool or key;

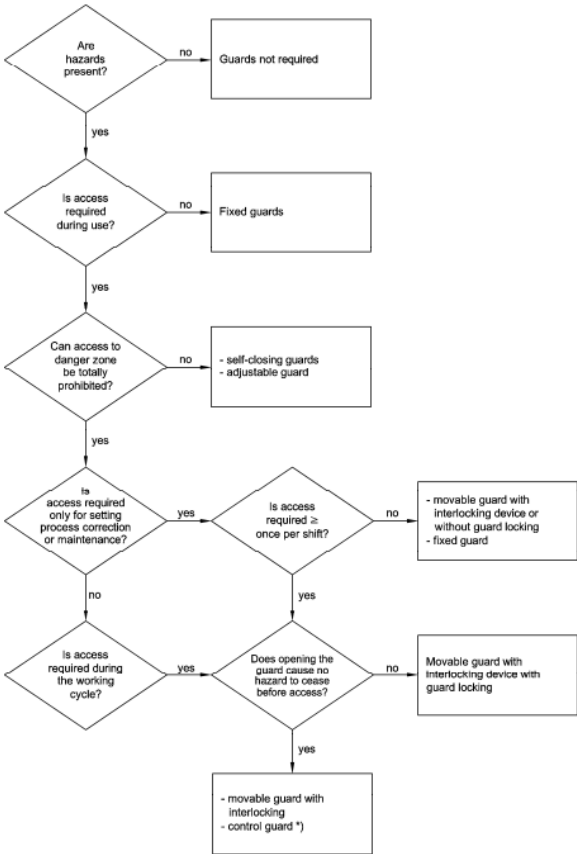

Figure 1: Selection Process of Guards

- If it is not reasonably practical to use any of the above guards a **presence-sensing guarding system** is to be used.

Guarding of Workshop Equipment

Where guarding of any moving part of the machinery or plant does not eliminate the risk or it is not practicable to guard it, the employer must ensure that workers or other people do not operate or pass close to the moving part **unless a safe system of work is in place** to reduce the risks as far as practicable.

3.3 Types of Guards

There are a number of different types of physical guarding and protective devices available for the guarding of machinery. Each have different operating principles and therefore are far from being equally suitable for safety applications. Using the machine hazards outlined in **Appendix A**, a risk assessment based approach must be utilised to decide which guarding device or combination of guards is the most suitable for a specific application.

The range of safeguarding devices includes

- permanently and securely fixed physical barriers,
- distance barriers,
- interlocked physical barriers,
- presence sensing equipment,
- self closing guards and
- two-hand control devices.

See **Appendix B** for the detail of the different types of guarding options.

3.4 Combination of Guards

It may be often appropriate to use a combination of different guards to ensure the safe operation of plant or machinery. This may be the case if a machine has several different danger zones and access is required to one or more of them during the operating phase. An industrial robot is good example of this, generally requiring fixed physical barriers due to the size of the danger zone, presence sensing devices such as light curtains to allow stock movement and interlocked doors (e.g. captive key) to allow operator access.



Figure 2 – Combination of guards

3.5 General Requirements

3.5.1 Guard Design Requirements

Manufacturers and designers of plant must provide equipment which is safe for its intended use.

Details of these safety requirements should be part of the original equipment manufacturer manual (OEM). Where Stanwell designs or manufactures plant and equipment further action must be taken to align with the relevant requirements of the Workplace Health and Safety Act 2011.

Regardless of the type of guard it must be suitable for its intended use taking into account the hazards associated with the machinery and the work environment. As far as practically possible, guards shall pose a minimal interference with normal operating activities of the machinery to reduce any incentive to by-pass or defeat them.

In addition to guarding posing minimal interference guards must also:

- Be of a robust construction;
- Not give rise to any additional hazards;
- Not be easy to by-pass or render non-operational;

Guarding of Workshop Equipment

- Be located at an adequate distance from the danger zone;
- Cause minimal obstruction to the view of the production process; and also
- Where practical, enable essential maintenance and housekeeping work to be carried out without the guard or protective device having to be removed.

3.5.2 General Workshop Requirements

All plant and equipment used in workshops shall comply with the relevant Australian and Stanwell standards.

The guarding requirements for plant and equipment for a workshop are many and varied but generally fall under the requirements of AS4024.1 series of standards. Safety requirements are, but not limited to;

- Guarding shall be designed into the machine and its process relative to the risk associated with its operation.
- All “Original Equipment Manufacturers” (OEM) supplied safety devices shall be installed and maintained as part of the safe operation of the machine.
- Plant and equipment shall be designed so that inspection, service and maintenance, set-up tasks and other required operations can be conducted in a safe manner.
- All hazards and risks associated with the maintenance and use of the plant shall be identified and addressed in a manner appropriate to the risk level. For the risk assessment of workshop plant and equipment, use the SCL Risk Evaluation Matrix GOV-STD-11 as a reference.
- Guarding and other identified controls shall be present and maintained to eliminate contact with the identified hazards.
- The workspace around a machine work-zone shall be kept clean, tidy and free of obstacles, slip, trip and fall hazards, rubbish and the like.
- Plant and equipment shall be fitted with an emergency stop push button.
- Plant and equipment shall have a method for full isolation and stored energy dispersal.
- Plant and equipment that requires PPE for its operation shall have the appropriate signs on or around the machine.
- Plant and equipment shall be subjected to scheduled audits and inspections.
- Operations, service manuals and other documentation shall be in English and made readily available (hard copy or online).
- Safety related devices such as emergency stops, light curtains, guard interlocks shall be periodically tested and the results recorded.

3.5.3 Emergency Stop

An emergency stop shall be fitted to all machines which are part of an electrical installation.

All personnel have the authority to stop equipment in the event of an emergency using the “Emergency Stop” devices provided. The type of emergency presented, the initial action and the follow-up action will depend on the circumstances surrounding the emergency.

There are two main types of emergency stop devices and these take the form of

- An emergency stop push button (see detailed requirements in **Appendix C**)
- An emergency stop pull-wire also known as a lanyard (These are typically found running along side conveyors).

4.0 Inspection

Periodical and pre-start inspections will be carried-out in order to ensure that the plant and equipment is maintained to the required standard. All inspections shall be addressed through the standard work order process in Ellipse, with records filed in TRIM.

Guarding of Workshop Equipment

4.1 Periodical / Annual Inspection

Workshop plant and equipment shall be periodically inspected to ensure that their condition remains safe and serviceable. The inspection process will be conducted on an annual basis, and will address serviceability of operational and safety components.

After each shut-down of plant and equipment, where the plant or equipment was taken out of service for any reason (maintenance, repair, safety issues, etc.), a return to service (RTS) inspection shall be conducted. This inspection is conducted to ensure that the plant and equipment has been returned to safe condition prior to starting the equipment. E.g have all guard been replaced.

The table used for the periodical / annual or RTS inspection is found in Appendix D Machine Inspection Checklist

4.2 Safety Review

Every five years a safety review will be conducted to verify the inspection process, establish contemporary compliance of safety features, re-establish details of plant owners and rationalise the number of persons recognised as being familiarised in that item of plant.

The Workshop Responsible Person will coordinate the process with the involvement of the site Health and Safety Department if required. The Workshop Responsible Person is responsible to ensure the routines are established in the sites Maintenance Management System (e.g. Ellipse).

The table used for the five yearly review is found in Appendix E Machine Safety Review Tool.

4.3 Pre-start Inspection

In addition to the formal inspection processes all workers have to inspect the workshop plant equipment before commencing their work to ensure that the plant and equipment is in a safe condition. See the related Stay Safe documents for the machine specific requirements covering the following workshop equipment including but not limited to the following:

- Lathes;
- Band saws;
- Cold saws;
- Pedestal and radial drills;
- Guillotines;
- Abrasive cut-off saws;
- Hydraulic presses;
- Milling machines;
- Linishing sanders; and
- Fixed grinders.

5.0 Signage and Labelling

Signs and labels must be suitable for the intended purpose. Signage and labelling should consider the use of universal symbols - in addition to the written message - where the sign needs instant recognition in a critical situation.

Where symbols are used for signs, they must follow AS1319 Safety signs for the occupational environment.

The minimum required safety signage is determined in the machine specific field posters.

When new signs are introduced or existing signs are changed, employees should be advised beforehand such as in pre-start meetings, toolbox talks, inductions and by other suitable means.

Guarding of Workshop Equipment

6.0 Supervision, Information and Training

Supervision, information and training will be provided for workers on site to ensure that workshop plant and equipment use is conducted in a way which is safe.

6.1 Supervision

All work areas which contain workshop plant and equipment will have a person nominated (Workshop Responsible Person) to be in control of that area or of the workgroup primarily using that area.

The Workshop Responsible Person should be appointed by the relevant Manager (e.g. Maintenance Manager) who is responsible for the Workshop.

The Workshop Responsible Person will have responsibility for the upkeep of that equipment, ensure that annual inspections of equipment is undertaken, action requirements from safety audits and record details of annual inspections.

The Workshop Responsible Person will control the familiarisation process in a manner that they will know who is familiarised in the workshop plant and equipment and under what conditions the plant and equipment's use may occur and records maintained in the Learning Management System.

The level of supervision at any point in time will consider the following factors:

- the type of work being conducted,
- the level of experience of the worker i.e.
 - Documented qualifications that demonstrate experience, ability and competency in the safe use of the plant / equipment;
 - Specific knowledge of the safe and correct use of the plant / equipment;
 - Area specific familiarisation;
 - Experience (i.e. previous involvement and familiarity) in the safe use of the plant / equipment
 - Familiarisation with the specific plant and equipment (when safe use of the plant or equipment is not covered by the Area Specific Familiarisation);
- Trainees, apprentices and personnel without formal and accepted trade qualifications can use workshop plant and equipment if:
 - Completed the relevant Area Specific Familiarisation and
 - Works under the direct supervision of an appropriately qualified worker.

6.2 Information

The new employee induction and familiarisation process shall include information relating to the guards used around the site that are relative to their position.

Key items of plant and their specific hazards will be addressed within Area Specific Familiarisations and Stay Safes.

Re-inductions / familiarisations will be required in accordance with sites access and training policies and procedures or when new or significant changes are made to a workplace or task.

6.3 Training

It is anticipated that persons who will use general workshop machinery have experience, ability and competency in the safe use of the plant / equipment.

Area / machine specific familiarisation shall be provided to all personnel who work on or around plant and equipment in workshops. The familiarisation shall cover specific elements of the safe and correct use of the plant / equipment in the area covered by the familiarisation.

Guarding of Workshop Equipment

6.4 Recognition of prior learning

Persons using general workshop equipment should have industry level trade qualifications in the plant used and undergone familiarisation.

Non-trade personnel can use workshop plant and equipment if demonstrating qualification / experience equivalent with the accepted trade qualifications and undergone the area / machine specific familiarisation.

6.5 Specialised workshop plant

Persons conducting unsupervised work using specialised plant for precision work, for example milling machines or lathes, must be familiarised and have held trade based competencies equivalent but not limited to:

- MEM18003C: Use tools for precision work
- MEM07011B: Perform complex milling operations
- MEM07021B: Perform complex lathe operations

6.6 Training Records

Training records will be held in the Learning Management System.

7.0 Operational & Maintenance Documentation

All documentation of the Periodical / Annual Inspection and the Safety Audit will be recorded in TRIM and managed through Ellipse as well as the records of familiarisations.

OEM operational manuals will be accessible in the workshops where the covered plant and equipment are (hard copy or online).

All maintenance records should be kept in in TRIM and managed through Ellipse.

All workshop plant and equipment related records should contain the available identification of the plant / equipment (make, model, serial, year of manufacture, asset number) to allow traceability and identification.

8.0 Hiring & Purchasing of Workshop Plant & Equipment

All hired and newly purchased plant and equipment must be inspected by a site responsible person prior to being used or operated on site, to ensure it complies with all relevant Australian Standards, Stanwell standards and relevant codes of practice.

9.0 Responsibilities

9.1 Site Manager

Ensures that the procedure is implemented on the site. Delegates the tasks and responsibilities coming from this procedure to the relevant managers.

9.2 Managers / Superintendents (Workshop owners)

Appoints the Workshop Responsible Persons and provides them adequate resources to manage the workshops and fulfil their duties coming from this procedure.

Have overarching responsibility over the workshops(s) in their area.

9.3 Workshop Plant and Equipment Operator

Guarding of Workshop Equipment

Responsible for the safe use of workshop plant / equipment.

Responsible for the Pre-start Inspection on workshop plant / equipment to ensure it is safe to use. Initiate actions and take the plant / equipment out of service if any fault / non-conformance is identified.

Responsible to ensure they have been familiarised on the workshop equipment item before they operate the apparatus.

9.4 Workshop Responsible Person

The Workshop Responsible Person will coordinate the periodical / annual / RTS inspection and review process as well as the 5 yearly Safety Auditing and is responsible to ensure the routines are established in the sites Maintenance Management System (e.g. Ellipse).

Responsible for the management of records and corrective actions related to the above inspections and audits as well as the record management of maintenance activities.

Responsible for the record management of workshop plant and equipment familiarisation.

10.0 Review, Consultation and Communication

Review:

This document is required to be reviewed, as a minimum, every 3 years.

Consultation:

Changes to this document require consultation with the Corrective Action Review board.

Refer to Business Procedure: Health, Safety and Environment Consultation and Participation HSE-PROC-13 for further information.

Communication/Requirements after Update:

Communication following updates to this document requires coordination by the Corporate Safe Work Systems Committee.

11.0 References

- Workplace Health & Safety Act 2011 & Regulation 2011
- AS4024.1 – 2006 2014 – (Series) – Safety of Machinery
- AS1657 - 1992 2018 – Fixed platforms, Walkways, Stairways & and Ladders
- AS4024.3610- 2000 2015 –Safety of Machinery - Conveyors
- AS1319-1994- Safety Signs for the Occupational Environment

Guarding of Workshop Equipment

12.0 Definitions

Item	Definition
Emergency Stop	A manual or automatically operated system designed to stop plant or equipment (including conveyor) in the shortest practicable time in an emergency. (AS4024.3610 – 1.6.6)
Emergency Stop - Pull-wire (Conveyor emergency stop device)	A wire connected to a device, normally provided for emergency stop control which, when pulled, activated the device. (AS4024.3610 – clause 1.6.17)
Guard	Part of a machine specifically used to provide protection by means of a physical barrier. Depending on its construction, a guard may be called Casing, Cover, Screen, Door, Enclosing guard etc.
Guard - Temporary Guarding	A shield, fence, enclosure, cover, casing, mesh and other similar enclosing device that is used in place of the original guarding which may have been removed to facilitate access. The safe provisions of a temporary guard shall be the same as the original guard and is set in place for a defined period. Note: Temporary guarding is not to permanently replace the original guard.
Workshop Responsible Person	Persons in control of a work area – refers to a Superintendent or other works responsible person who has direct control over the delegation and management of work which occurs on workshop plant and equipment

13.0 Revision History

Rev. No.	Rev. Date	Revision Description	Author	Endorse/Check	Approved By
0	09.05.2019	Document created	Balazs Bagyinszki	Owen Bevan	James Oliver
1	22.03.2022	Document updated with Appendix D & E that were previously controlled forms. Review of content in procedure not undertaken.	Natasha Harding	Natasha Harding (for consolidation group)	Letitia Lucke
2	28.06.2022	Periodic review completed. Updated with new procedure references (HSE). No changes to relevant AS's. No material changes to content	Letitia Lucke	Trent Hoare	Letitia Lucke

Guarding of Workshop Equipment

14.0 Appendices

14.1 Appendix A – Mechanical Hazards of Workshop Machinery

The critical controls and performance standards in this procedure apply to hazardous equipment (i.e. mobile, fixed, large or portable) at Stanwell operations where people could be seriously injured if they come into contact with moving parts of machine workshop plant or equipment.

This applies for exposure to equipment during operation, maintenance and troubleshooting, with the primary exposure areas being:

- Parts which move or transmit power
- Parts that do the work

ILLUSTRATION NOTE:

Please note the below items of plant have been illustrated below without guarding to demonstrate the hazards and danger zones.



Hazard Point



Rotation/Linear Motion

14.1.1 Drawing-in or Trapping Hazards

Drawing-in and trapping hazards are created by a rotating surface and another adjacent surface which create a 'nip point'. A nip point may be formed;

- Two counter-rotating parts, for example meshing gears.

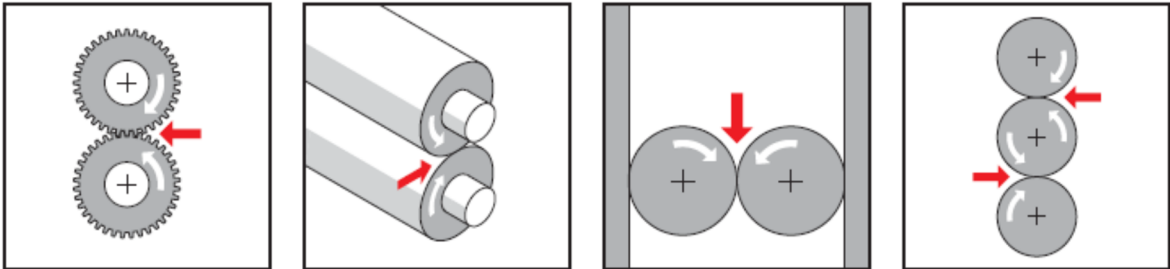

Figure 1 – Drawing hazards diagrams

- A rotating surface and tangentially moving surfaces, for example a power transmission belt and its pulley, a chain and sprocket, and a rack and pinion.

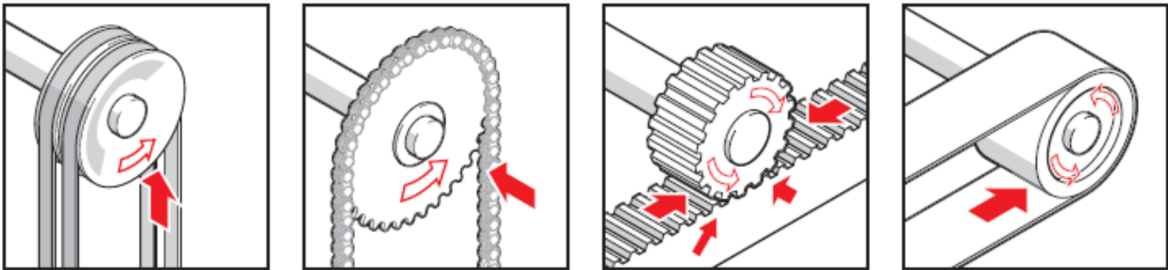

Figure 2 – Trapping hazards diagram

- Rotating and fixed parts which create a shearing, crushing or abrading action, for example flywheels and screw conveyors.

Guarding of Workshop Equipment

14.1.2 Entanglement Hazard

Entanglement hazards are created by a rotating piece of machinery. Injury is caused by the entanglement of body parts, items of clothing, jewellery, rags, hair with the rotating part, including:

- Contact with a single rotating surface, for example a smooth shaft, couplings, spindles, chucks, mandrels or rotating work pieces.

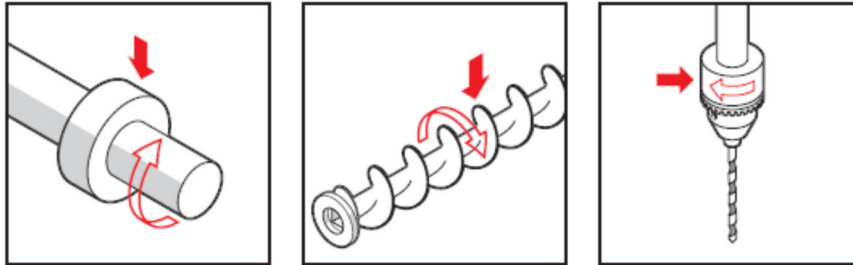

Figure 3 – Entangling hazards diagram

- Being caught on projections or in gaps, for example projection hazards such as belt fasteners and set screws, or gap related hazards such as fan blades, spoken pulleys and gear wheels.

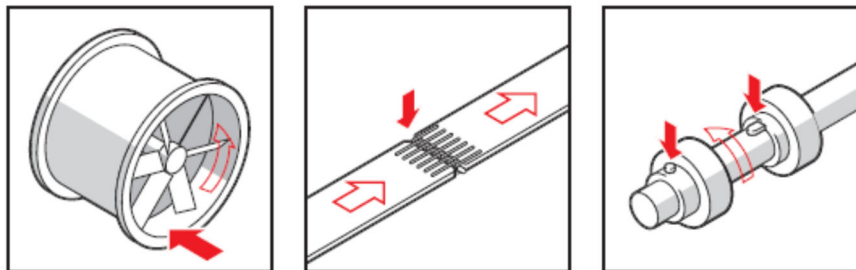

Figure 4 – trapping hazards diagram

- Contact between rotating and fixed parts, for examples screw conveyors and their casings, the periphery and abrasive wheel and incorrectly adjusted work rest.

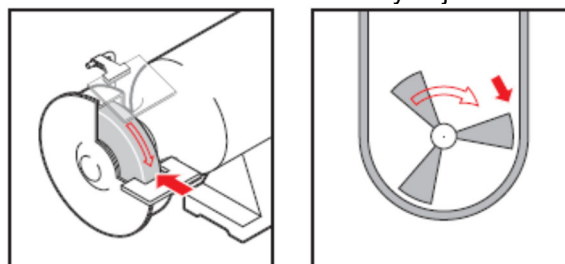

Figure 5 – Rotating part hazards diagram

- Contact between counter rotating parts, (see Drawing-in Hazards).
- Contact between rotating and tangentially moving parts, (see Drawing-in Hazards).

14.1.3 Shearing Hazards

Shearing hazards are created by two linear moving objects with a thin geometry moving in close proximity to each other or also rotating objects adjacent to stationary object. Some examples of shearing hazards include;

- Between two machine parts, for example connecting links and rotating wheels or parts that oscillate.

Guarding of Workshop Equipment

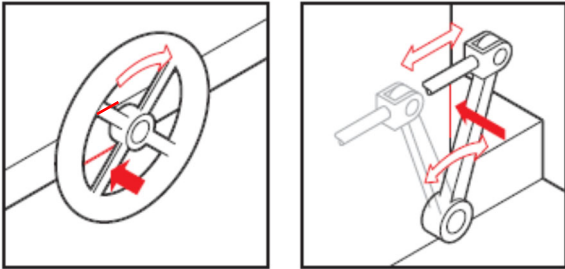

Figure 6 – Shearing hazards diagram

- Between a machine part and work piece, for example a sampler and surrounding transfer equipment or casing.

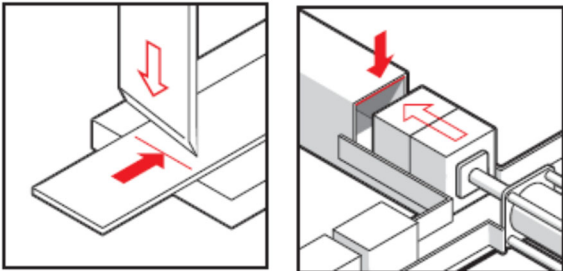

Figure 7 – Sliding hazards diagram

14.1.4 Cutting Hazards

Cutting hazards are created at the point of operation of a cutting tool and a work piece. Cutting tools can take various forms including cutting, boring, drilling, planing, water jet cutting and laser cutting.

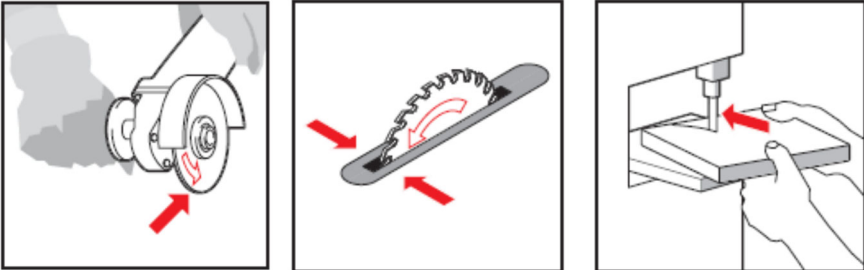

Figure 8 – Cutting hazards diagram

14.1.5 Impact Hazards

Impact hazards related to plant or machinery that strikes the human body, but does not however penetrate, for example rotating robot arm. Impact hazards differs from crushing hazards in that impact hazards operate against the inertia of the body whereas crushing involves the trapping of the body between two moving parts of a moving and a stationary part. Below are two illustrations of impact hazards.

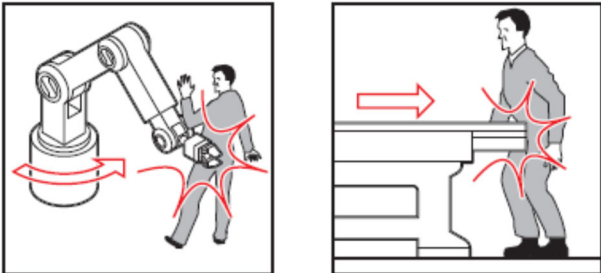

Figure 9 – Impact hazards diagram

Guarding of Workshop Equipment

14.1.6 Stabbing and Puncturing Hazards

The human body can be penetrated by fast moving objects such as ejected debris of machine components or rapidly moving parts of machinery for example a drill bit.

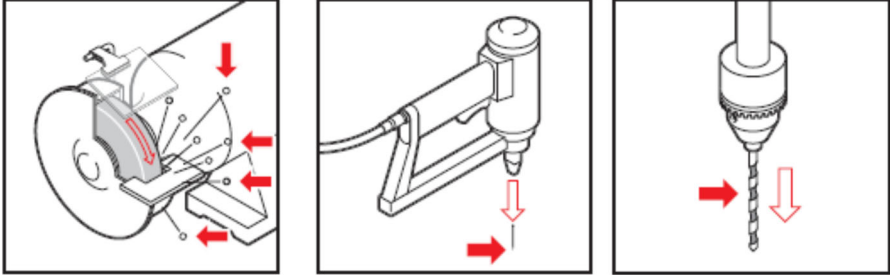

Figure 10 – Puncturing hazards diagram

14.1.7 Crushing Hazards

Crushing is caused by the movement of two objects moving closer in proximity to each other, trapping part of the human body. It differs from shearing hazards as the part of the human body is not severed. Crushing occurs when the human body is trapped, either between a moving object and a stationary object or two moving objects;

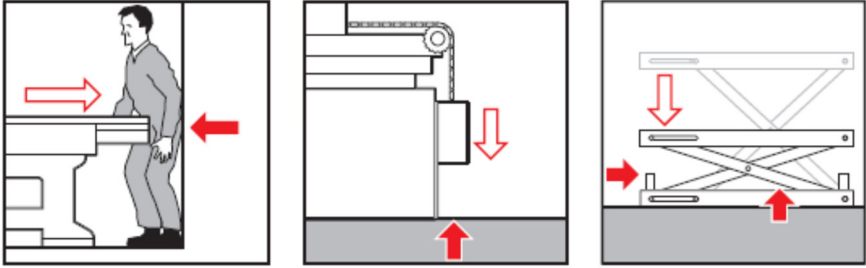

Figure 11 – Crushing hazards diagram

MINIMUM GAP TO PREVENT CRUSHING HAZARD

AS4024.1803 establishes values for the minimum gap to prevent crushing hazards. This information can assist assessors in the identification of crushing hazards.

14.1.8 Friction Abrasion Hazards

Friction burns can be caused by smooth parts moving at high speed as well as rough parts, for example the wheel of a grinding machine, a conveyor belt and pulleys, and a fast moving rope or cable.

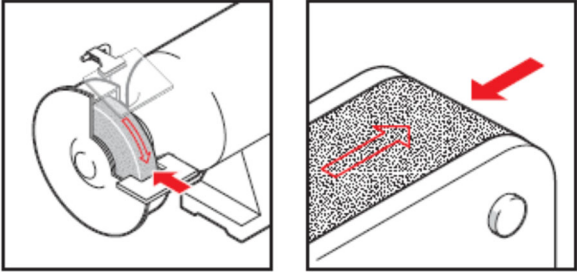

Figure 12 – Friction hazards diagram

14.1.9 Other Hazards

It is important that Stanwell also identifies the less obvious hazards that originate from energy sources other than that of mechanical hazards. These energies are clearly outlined as part of the SafeStart booklet. The SafeStart should be utilised prior to starting work as a minimum.

Guarding of Workshop Equipment

14.2 Appendix B – Types of Guards

14.2.1 Permanently Fixed Physical Barrier

A permanently fixed barrier is a physical barrier that is either welded or incorporated into the body of the machine so that it cannot be removed by the use of hand tools. It is only used for machinery or equipment in which, during normal operation, maintenance or cleaning, no person would need complete or partial access to the dangerous area.

14.2.2 Securely Fixed Physical Barrier (Fixed Guard)

A 'securely fixed guard' is a physical barrier securely held in position by the use of fasteners (bolts, screws, etc) making removal without the use a tool impossible. Its primarily function is to prevent access to the space enclosed by the guard however it also may be used to contain materials, tools, or liquids ejected by machinery and/or reduce emissions such as noise, dust, fumes emitted by machinery.

In reference to fixed guarding, a tool is considered to be a key or wrench designed to operate a fastener. Improvised tools such as coins or scrap metal are not considered to be a tool. Also fasteners such as wing nuts and wedge inserts can be operated by fingers thus do not satisfy the requirements of guarding fasteners.

This type of guarding should be easy to remove and install, however it should not remain closed with the fasteners removed.

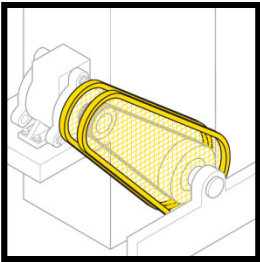

Figure 1 – Illustration of a belt and pulley safeguarded through implementation of a fixed guard

Fixed guarding must only be removed once the machine is isolated and the stored energy of the machine is released. Conversely, the machine must only be de-isolated after the guard has been repositioned in the closed position and the fasteners reinstated.

14.2.3 Distance Guard

A distance guard is a fixed physical barrier which does not completely enclose a danger zone, yet prevents access by virtue of its dimensions and the distance between the guard and hazard zone. Any access points through the barrier, including doors and gates, must be secured with a lock or interlocking system.

14.2.4 Interlocking Physical Barriers (Control Guard)

Interlocking guards are a type of movable guard. Movable guards are physical barriers that are generally connected by mechanical means such as slides and can be opened without the use of tools. This movable physical barrier is also interconnected with the power or control system of the machine. Interconnections are usually electrical, mechanical, hydraulic or pneumatic and provide an effective safeguard where access to the hazard point is required between each machine cycles or where regular access is needed.

The interconnection prevents the machinery from operating unless the guard is closed and if the guard is opened while hazardous machine function are operating a stop signal is given to the control system. These should not replace effective isolation. Closing the guard again will enable

Guarding of Workshop Equipment

the operation of the hazardous machine functions however it does not automatically initiate the operation.

Interlocking guards can be differentiated into two separate groups:

- **Interlocked guard with guard locking**
The movable physical barrier is secured by a locking device that does not allow the machine to be operated without closing and locking the guard and does not allow the opening of guard until the hazardous machine functions have ceased.
- **Interlocked guard without guard locking**
The movable physical barrier is able to be opened at any time. The safeguarding of the system is based on the machines ability to cease the hazardous machine functions before a person or part of a person can move into hazard zone.

14.2.5 Presence Sensing Equipment

Presence sensing devices do not rely on physical barriers to segregate persons from a hazard zone instead using sensing mechanisms to detecting parts of the human body or persons approaching a hazard zone. Once the body part or person goes beyond the predetermined limit a signal is generated to the control system to reduce the risk to the person detected. The system relies on the machine being able to stop quickly (which may be brake assisted) to ensure that the machine stops before a person moves into a position where they could be injured.

Presence sensing equipment requires selection of a sensing mechanism appropriate for the work being done, and the correct mounting location taking into account speed and distance of entry and machine stopping time.

The range of sensitive protective equipment includes but is not exclusive to:

- Light curtains;
- Scanning devices (eg. Laser scanners); and
- Pressure sensitive mats;

These devices are far from equal in their ability to prevent or minimise the risk associated with certain types of machinery and their implementation must be in accordance with Australian Standards. These technologies are also precluded from a number of machinery applications, where there is:

- A tendency for the machinery to eject materials or component parts
- Necessity to guard against emissions (eg. dust, radiation, noise, etc)
- Erratic or excessive machine stopping time
- Inability for the machine to stop midway through the cycle.
- Work areas with high levels of air borne dust (does not preclude pressure sensitive devices)

Guarding of Workshop Equipment

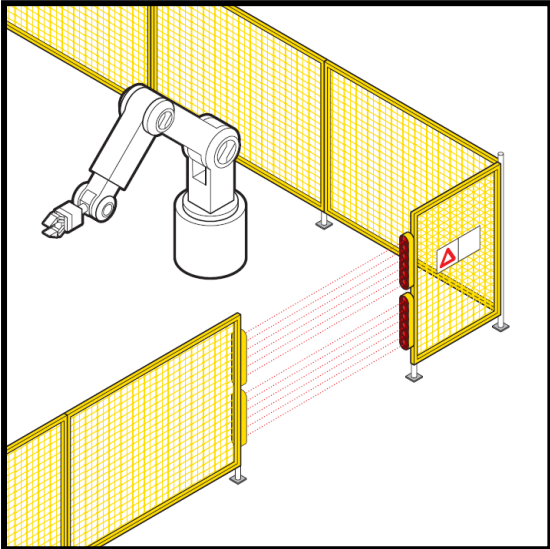

Figure 2 – Presence Sensing Equipment

Presence sensing equipment shall be integrated into operative part and associated with the control system of the machine so that –

- A command is given as soon as the person or part of the human body is detected;
- The withdrawal of the person or part of the person detected does not, by itself, restart the hazardous machine function(s); therefore, the command given by the sensitive protective equipment shall be maintained by the control system until a new command is given;
- Restarting the hazardous machine function(s) results from the voluntary actuation, by the operator, of a control device placed outside the hazard zone, where this zone can be observed by the operator;
- While the detection function of the sensitive protective equipment is interrupted the machine cannot operate, except during muting phase (see AS 4024.1501);
- The position and the shape of the detection field prevents, possibly together with fixed guards, a person or part of a person from entering the hazard zone, from being present in it without being detected.

14.2.6 Self-Closing Guards

Self-closing guards are movable guards that are operated by a machine element, work piece or machining jig, so that it allows the work piece to pass and then automatically returns to the closed position. This returning to the closed position may be influenced by means of gravity, spring force, external power.

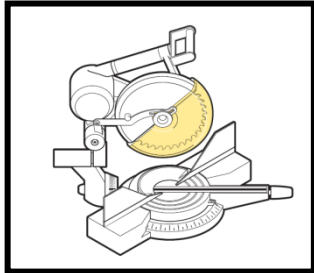

Figure 3 – Self closing guard

Self-closing guards are most commonly encountered in workshop environment; however some laboratory and processing equipment may be fitted with this type of guarding device. All plant and equipment originally fitted with self closing guards must only be operated with the guard fitting in place, unless determined otherwise by risk assessment.

Guarding of Workshop Equipment

14.2.7 Two-Hand Control Device

Two-handed control devices require the operator of a machine to simultaneously activate the machine with both hands; this two-hand activation is required to be maintained throughout the hazardous condition cycle. Although two-handed devices can be an effective protection measure for the individual operator of the machinery, they can in some instances be easily defeated. They also do not afford protection to any other person inside or near the danger zone.

Two hand control devices are frequently found in laboratories and machining workshops. Two hand control devices shall be designed and arranged in such a way that the protective effect of the two-hand control device cannot be easily defeated and the probability of accidental actuation is minimised.



Figure 4 – Two hand control device

The design and implementation of two-hand control devices is outside the scope of this guarding guidance document, design requirements can be found in: AS4024.2601 “Design and controls, interlocks and guarding – Two-hand control devices – Functional aspects and design principles”.

14.3 Appendix C Emergency Stop Push buttons

For general plant and equipment typically push buttons emergency stops are used.

An emergency stop device shall be located at each operator control station, except where the risk assessment indicates that this is not necessary, as well as at other locations, as determined by the risk assessment. It shall be positioned such that it is readily accessible and capable of non-hazardous actuation by the operator and others who could need to actuate it. Measures against inadvertent actuation should not impair its accessibility.

When determining the exact location of the emergency stop device, take into account the location and the nature of the hazards identified in the risk assessment and ensure that the emergency stop device can be operated easily even if the operator is entangled by the machine (i.e. if the hazard is the entanglement of the arm of the operator, install the emergency stop device in knee height in the location where the entangled operator can actuate it).

Push buttons shall;

- Have a red mushroom head that is quite large and easy to access
- The switch shall be a pushbutton
- When the push button is pressed then it shall lock in the “Off” (depressed) position
- It will need to be manually released to allow the button back into the “ready” position
- The switch shall have a sign on it stating that it is an emergency stop
- Be periodically tested to ensure that it works or use effective isolation and reactivation.



Figure 5 – Emergency Stop Switch

Business Procedure

14.4 Appendix D Machine Inspection Checklist

MACHINE INSPECTION CHECKLIST for Periodical / Annual / Return to Service Inspections of Workshop plant / equipment					
Make		Model		Serial number	
Asset number		Short description		Location	
Year manufactured		Inspected by		Inspection date	

If any action is required, raise a Hazard in EARS and control the actions through event management

Item #	Criteria	Yes/No/ N/A	Is control action needed? If yes, provide detail	Comments / Notes
1	Are records of plant maintenance and inspections available?			
2	Is access restricted to plant for unauthorised personnel?			
3	User manual for the plant available in English?			
4	Are controls labelled properly, in good condition and in English?			
5	Are guards provided as per the original design for moving parts of the machine?			
6	Are PPE requirements for the plant other than minimum site PPE determined and signed at the plant?			
7	Are there emergency stops installed and works adequately on the machine?			
8	Are emergency stops in a suitable location for operator emergency use?			
9	Is the machine fixed/secured in place correctly?			
10	Are electrical cables and fixtures in undamaged condition?			

WRITTEN BY: L. Lucke

ENDORSED/CHECKED BY: T. Hoare

APPROVED BY: L. Lucke

Guarding of Workshop Equipment

14.5 Appendix E Machine Safety Review Tool

MACHINE SAFETY REVIEW TOOL				
for the conducting of safety auditing of workshop plant / equipment				
Make		Model		Serial number
Asset number		Short description		Location / Workshop
Year manufactured		Audited by		Audit date

If any action is required, raise a Hazard in EARS and control the actions through event management

Item #	Criteria	Yes/ No/ N/A	Is control action needed? If yes, provide detail	Comments / Notes
1	Minimum Control Requirements			
1.1	Is Operators Manual available?			
1.2	Are equipment maintenance records available?			
1.3	Is there a process for recording area / machine specific familiarisation?			
1.4	All guards are in place & in good working order for this plant / equipment			
1.5	Safe working zones are defined for this plant / equipment (e.g. yellow lines and / or appropriate signage)			
1.6	Suitable personal protective equipment (PPE) and appropriate signage is available			
1.7	This plant / equipment complies with relevant safety standards			

Guarding of Workshop Equipment

Item #	Criteria	Yes/ No/ N/A	Is control action needed? If yes, provide detail	Comments / Notes
2	Exposure to rotating or moving parts			
2.1	Entanglement & Entrapment Could hair, clothing, jewellery or other materials become entangled with moving parts of plant or materials in motion?			
2.2	Striking Could anyone be struck by moving objects such as the workpiece being ejected, or by the unexpected or uncontrolled movement of the plant or workpiece?			
2.3	Crushing & Piercing Could anyone be crushed or pinched due to falling, uncontrolled movement of plant or its load tipping or rolling over, or contact with moving parts?			
2.4	Shearing Can body parts be cut off between two parts of the plant, or between a part of the plant & the workpiece or structure?			
2.5	Cutting, Stabbing & Punctuating Can anyone be cut, stabbed or punctured by coming into contact with moving plant or parts, or objects such as ejected workpiece or waste?			
3	Slips, Trips & Falls Can anyone using the plant or in the vicinity of the plant, slip, trip or fall due to the working environment or other factors?			
4	Environmental			
4.1	Noise Is it likely that the normal operation of this plant will produce excessive noise levels?			
4.2	Dust, Fumes & Vapours Is it likely there will be airborne dust particles, toxic fumes or volatile vapours produced & therefore be present in the workspace?			

Guarding of Workshop Equipment

Item #	Criteria	Yes/ No/ N/A	Is control action needed? If yes, provide detail	Comments / Notes
4.3	Lighting Is there insufficient lighting to operate this plant in a safe manner? Is there a possible strobe lighting effect caused by faulty fluorescent tubes in the workspace?			
4.4	Temperature Is the ambient room temperature too extreme & therefore likely to cause the operator discomfort or lack of concentration?			
5	Electrical Can the operator be injured by electrical shock due to working near or contacting with damaged or poorly maintained live electrical conductors such as power outlets, extension leads, safety switches, starters & isolators or casual water on the floor near plant & machinery?			
6	Hazardous Substances Is it likely that the plant operator or others nearby in the workspace could be exposed to hazardous or toxic chemicals?			
7	Ergonomics & Handling Can the plant be safely operated, in a suitable location, providing clear & unobstructed access? Poorly designed work stations often necessitate workers performing manual tasks involving heavy lifting & lowering, pushing, pulling or carrying, etc. Such tasks then contribute to a range of musculoskeletal sprains & strains for workers.			
8	Explosion & Fire As a consequence of using this particular item of plant & equipment, could anyone be injured by the release of stored energy triggered by volatile, explosive substances such as stored gasses, vapours or liquids?			
9	Other Hazards			