

DRUM LOUVER PLENUM-DIFFUSER

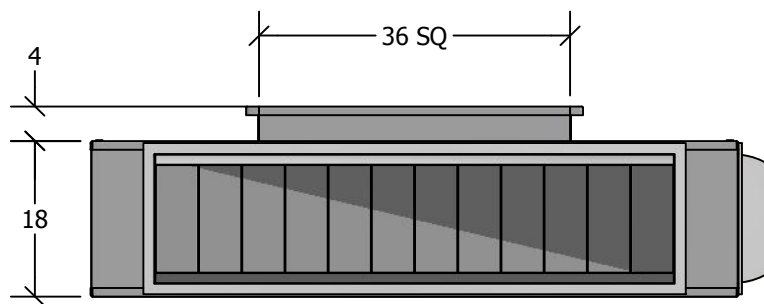

STANDARD FEATURES

1. G-90 Galvanized Steel Construction.
2. Turning Vanes in Each Quadrant.
3. 1" 1-1/2 lb. Duct Liner.
4. Vertical and Horizontal Adjustable Drum Louver.
5. Fully Assembled
6. TDC Duct Connections Provided.
7. 3/8" Threaded Inserts for Mounting.
8. Engineered Curb and Duct Packages Available.

NOM CFM 10,000	MODEL NO DLPD2C 6015-25	WEIGHT 173'
0° DEFLECTION		
THROW 89'-154'	P.D. .115"	NC 38
30° DEFLECTION		
THROW 61'-106'	P.D. .21"	NC 46

QTY TAG

JOB NAME

CURBS PLUS, INC.
www.curbs-plus.com