

## Concentric Diffuser System

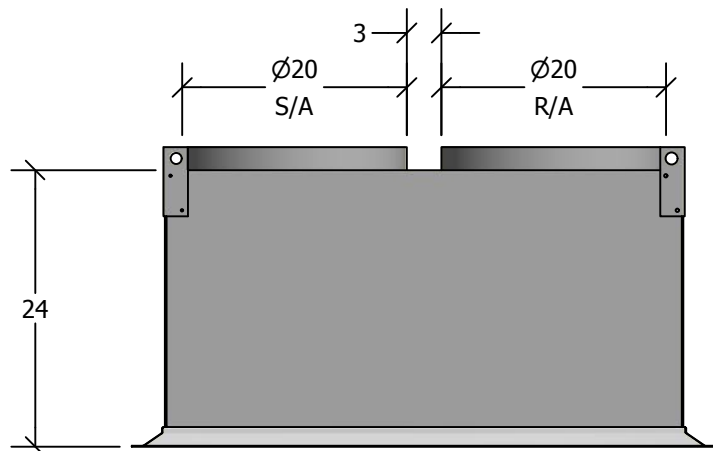

ENGINEERING DATA				
CFM	THROW	P.D.	NC	NECK VEL
3,000	15'-25'	.11	32	1,375
3,400	17'-28'	.13	37	1,558

### STANDARD FEATURES

1. G-90 Galvanized Steel Construction.
2. 1" 1-1/2 lb. Duct Liner.
3. Aluminum Louverd Face Grille with Egg Crate Return.
4. Exposed Surfaces Painted Off White Enamel.
5. Fully Assembled.
6. Designed for Lay In Ceiling Installation.
7. Engineered Curb and Duct Packages Available.

QTY TAG

JOB NAME

**CURBS PLUS, INC.**  
www.curbs-plus.com

MODEL NO  
CFR7.5-8.5

WEIGHT  
105 LBS.