

## SLANT FACE PLENUM DIFFUSER

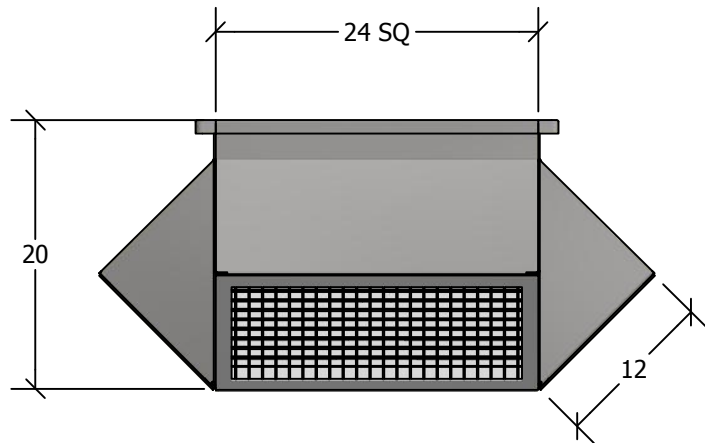

### STANDARD FEATURES

1. G-90 Galvanized Steel Construction.
2. Turning Vanes in Each Quadrant.
3. 1" 1-1/2 lb. Duct Liner.
4. Vertical and Horizontal Adjustable Deflection Grilles.
5. Fully Assembled
6. TDC Duct Connections Provided.
7. Engineered Curb and Duct Packages Available.

NOM CFM 4,000	MODEL NO SFPD 2210-10	WEIGHT 56 LBS
0° DEFLECTION		
THROW 56'	P.D. .12	NC 29
22 1/2° DEFLECTION		
THROW 43'	P.D. .13	NC 30
45° DEFLECTION		
THROW 25'	P.D. .20	NC 36

QTY TAG

JOB NAME

  
**CURBS PLUS, INC.**  
[www.curbs-plus.com](http://www.curbs-plus.com)