

SLANT FACE PLENUM DIFFUSER

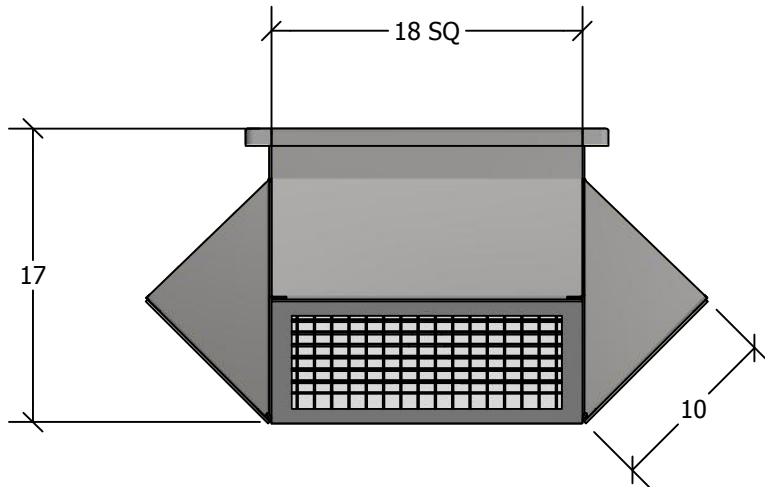

STANDARD FEATURES

1. G-90 Galvanized Steel Construction.
2. Turning Vanes in Each Quadrant.
3. 1" 1-1/2 lb. Duct Liner.
4. Vertical and Horizontal Adjustable Deflection Grilles.
5. Fully Assembled
6. TDC Duct Connections Provided.
7. Engineered Curb and Duct Packages Available.

NOM CFM 2,400	MODEL NO SFPD 1608-6	WEIGHT 36 LBS
0° DEFLECTION		
THROW 45'	P.D. .13	NC 30
22 1/2° DEFLECTION		
THROW 35'	P.D. .14	NC 31
45° DEFLECTION		
THROW 21'	P.D. .21	NC 37

QTY TAG

JOB NAME

CURBS PLUS, INC.
www.curbs-plus.com