

DRUM LOUVER PLENUM-DIFFUSER

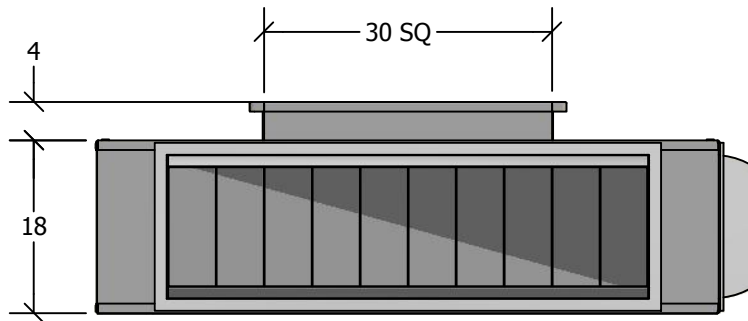

STANDARD FEATURES

1. G-90 Galvanized Steel Construction.
2. Turning Vanes in Each Quadrant.
3. 1" 1-1/2 lb. Duct Liner.
4. Vertical and Horizontal Adjustable Drum Louver.
5. Fully Assembled
6. TDC Duct Connections Provided.
7. 3/8" Threaded Inserts for Mounting.
8. Engineered Curb and Duct Packages Available.

NOM CFM	MODEL NO	WEIGHT
7,000/8,000	DLPD2C5015-17.5/20	143 LBS

0° DEFLECTION

THROW	P.D.	NC
77'-142'	.09"/.12"	32/37

30° DEFLECTION

THROW	P.D.	NC
53'-97'	.16"/.21"	40/45

QTY TAG

JOB NAME

CURBS PLUS, INC.
www.curbs-plus.com