

SLANT FACE PLENUM DIFFUSER

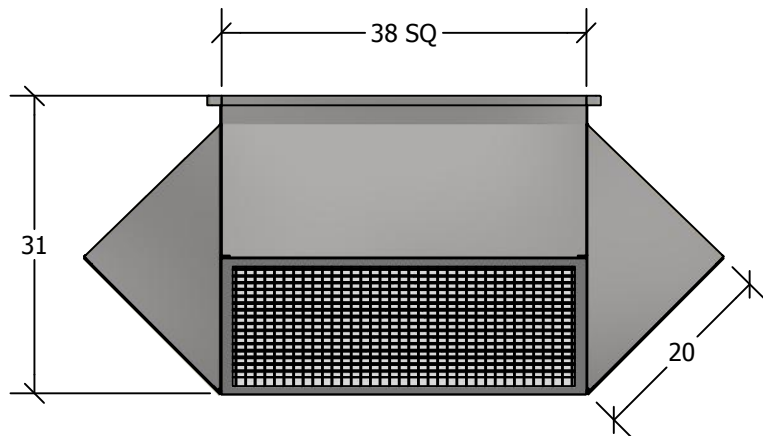

STANDARD FEATURES

1. G-90 Galvanized Steel Construction.
2. Turning Vanes in Each Quadrant.
3. 1" 1-1/2 lb. Duct Liner.
4. Vertical and Horizontal Adjustable Deflection Grilles.
5. Fully Assembled
6. TDC Duct Connections Provided.
7. Engineered Curb and Duct Packages Available.

NOM CFM 12,000	MODEL NO SFPD 3618-30	WEIGHT 181 lbs
0° DEFLECTION		
THROW 101'	P.D. .11	NC 34
22 1/2° DEFLECTION		
THROW 78'	P.D. .12	NC 35
45° DEFLECTION		
THROW 46'	P.D. .17	NC 41

QTY TAG

JOB NAME

CURBS PLUS, INC.
www.curbs-plus.com