

DRUM LOUVER PLENUM-DIFFUSER

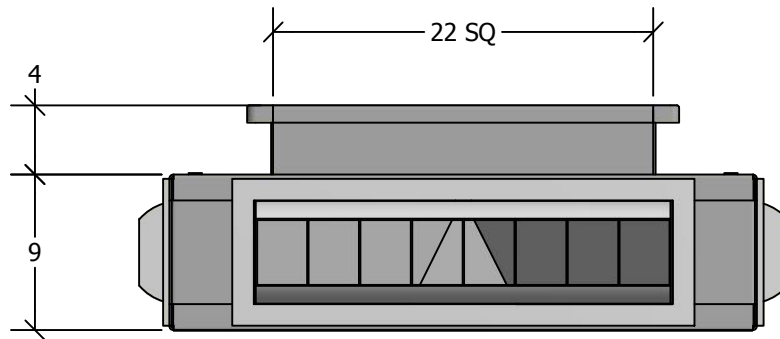

STANDARD FEATURES

1. G-90 Galvanized Steel Construction.
2. Turning Vanes in Each Quadrant.
3. 1" 1-1/2 lb. Duct Liner.
4. Vertical and Horizontal Adjustable Drum Louver.
5. Fully Assembled
6. TDC Duct Connections Provided.
7. 3/8" Threaded Inserts for Mounting.
8. Engineered Curb and Duct Packages Available.

NOM CFM 3,000/3,400	MODEL NO DLPD 2406-7.5/8.5	WEIGHT 87 LBS
------------------------	-------------------------------	------------------

0° DEFLECTION

THROW 78'/86'	P.D. .158/.2	NC 25/28
------------------	-----------------	-------------

30° DEFLECTION

THROW 55'/60'	P.D. .285/.366	NC 34/38
------------------	-------------------	-------------

QTY TAG

JOB NAME

CURBS PLUS, INC.
www.curbs-plus.com