



Installation and Operation Instructions

LED PriZm II Perimeter Lights

IMPORTANT! Read all instructions before installing and using. Installer: This manual must be delivered to the end user.

WARNING!
 Failure to install or use this product according to manufacturer's recommendations may result in property damage, serious injury, and/or death to those you are seeking to protect!

 **Do not install and/or operate this safety product unless you have read and understood the safety information contained in this manual.**

1. Proper installation combined with operator training in the use, care, and maintenance of emergency warning devices are essential to ensure the safety of emergency personnel and the public.
2. Emergency warning devices often require high electrical voltages and/or currents. Exercise caution when working with live electrical connections.
3. This product must be properly grounded. Inadequate grounding and/or shorting of electrical connections can cause high current arcing, which can cause personal injury and/or severe vehicle damage, including fire.
4. Proper placement and installation is vital to the performance of this warning device. Install this product so that output performance of the system is maximized and the controls are placed within convenient reach of the operator so that they can operate the system without losing eye contact with the roadway.
5. Do not install this product or route any wires in the deployment area of an air bag. Equipment mounted or located in an air bag deployment area may reduce the effectiveness of the air bag or become a projectile that could cause serious personal injury or death. Refer to the vehicle owner's manual for the air bag deployment area. It is the responsibility of the user/operator to determine a suitable mounting location ensuring the safety of all passengers inside the vehicle particularly avoiding areas of potential head impact.
6. It is the responsibility of the vehicle operator to ensure daily that all features of this product work correctly. In use, the vehicle operator should ensure the projection of the warning signal is not blocked by vehicle components (i.e., open trunks or compartment doors), people, vehicles or other obstructions.
7. The use of this or any other warning device does not ensure all drivers can or will observe or react to an emergency warning signal. Never take the right-of-way for granted. It is the vehicle operator's responsibility to be sure they can proceed safely before entering an intersection, drive against traffic, respond at a high rate of speed, or walk on or around traffic lanes.
8. This equipment is intended for use by authorized personnel only. The user is responsible for understanding and obeying all laws regarding emergency warning devices. Therefore, the user should check all applicable city, state, and federal laws and regulations. The manufacturer assumes no liability for any loss resulting from the use of this warning device.

Specifications:

	3x7	4x6	7x9
Size	1.5" x 4.75" x 9.0" (w/ bezel)	1.5" x 6.0" x 8.5" (w/ bezel)	1.5" x 9.0" x 11.0" (w/ bezel)
Weight	1.0 lbs	1.1 lbs	2.25 lbs
Operating Voltage	12 VDC		
Peak Current Draw ²	1.3 (8 LEDs), 1.6 (12 LEDs)		3.8 (24 LEDs), 4.6 (36 LEDs)



The use of this or any warning device does not ensure that all drivers can or will observe or react to an emergency warning signal. Never take the right-of-way for granted. It is your responsibility to be sure you can proceed safely before entering an intersection, driving against traffic, responding at a high rate of speed, or walking on or around traffic lanes.

The effectiveness of this warning device is highly dependent upon correct mounting and wiring. Read and follow the manufacturer's instructions before installing or using this device. The vehicle operator should insure daily that all features of the device operate correctly. In use, the vehicle operator should insure the projection of the warning signal is not blocked by vehicle components (i.e.: open trunks or compartment doors), people, vehicles, or other obstructions.

This equipment is intended for use by authorized personnel only. It is the user's responsibility to understand and obey all laws regarding emergency warning devices. The user should check all applicable city, state and federal laws and regulations.

Code 3, Inc., assumes no liability for any loss resulting from the use of this warning device. Proper installation is vital to the performance of this warning device and the safe operation of the

emergency vehicle. It is important to recognize that the operator of the emergency vehicle is under psychological and physiological stress caused by the emergency situation. The warning device should be installed in such a manner as to: A) Not reduce the output performance of the system, B) Place the controls within convenient reach of the operator so that he can operate the system without losing eye contact with the roadway.

Emergency warning devices often require high electrical voltages and/or currents. Properly protect and use caution around live electrical connections. Grounding or shorting of electrical connections can cause high current arcing, which can cause personal injury and/or severe vehicle damage, including fire.

PROPER INSTALLATION COMBINED WITH OPERATOR TRAINING IN THE PROPER USE OF EMERGENCY WARNING DEVICES IS ESSENTIAL TO INSURE THE SAFETY OF EMERGENCY PERSONNEL AND THE PUBLIC.

Unpacking and Pre-installation:

Carefully remove the light head from its protective packaging. Inspect the unit for transit damage. Report any damage to the carrier and keep the shipping carton. Verify the contents of the package (refer to Table 3 and Figures 2 and 3). Test the lights before installation. To test, touch the black wire to ground and the red wire to 12 VDC. If a problem occurs, contact the factory.

Installation and Mounting:

Step 1. Mark off and drill four ¼" diameter mounting holes and the 1" wire hole on the vehicles mounting surface using the dimensions shown for the appropriate light (refer to Figures 4, 5 & 6). Verify free clearance exists behind the mounting surface for wires and fasteners before drilling.

Step 2. Install customer supplied grommet in the 1" diameter wire hole. Install the four plastic grommets in the mounting holes (Code 3 supplied).

Step 3. Route the vehicle power wires and allow a minimum of 3" of slack to protrude from the center opening at each light head location. Use 18 AWG for wires up to 40' length, 16 AWG for wires up to 70' length.

Step 4. Refer to the section "Device Operation" prior to finalizing the electrical connections. Prepare the vehicle power wires and the light heads wires with terminations of the customer's choice (not supplied) as follows: Red: +12 VDC, Black: Ground, White: Program, Purple: Dim, Yellow: Sync, Green: Cutoff (refer to Figure 1). Waterproof connectors are recommended.

Step 5. Route the power wires through the center opening of the light gasket or bezel and bezel gasket (refer to Figures 2 and 3). Connect light head red (+12VDC) power wires and Black ground wires to the vehicle power system. Seal or cap the end of the white wire and other unused wires to prevent inadvertent changes to the flash pattern or unexpected operation of the device.

Step 6. Verify proper light head operation by supplying electrical power to the system wires.

Step 7. Push the assembled electrical connectors through the center opening and into the vehicle.

Step 8. Install the lens gasket over the light head.

Step 9. Place the light head onto the light gasket or bezel and bezel gasket. The bezel and all gaskets are marked with the word "Top". The light head is not, but should be installed such that the wire harness is located directly across from the hole in the vehicle body.

Step 10. Install onto the light head the outer lens and secure to the vehicle using the four supplied #6 x 1 ¼" screws.

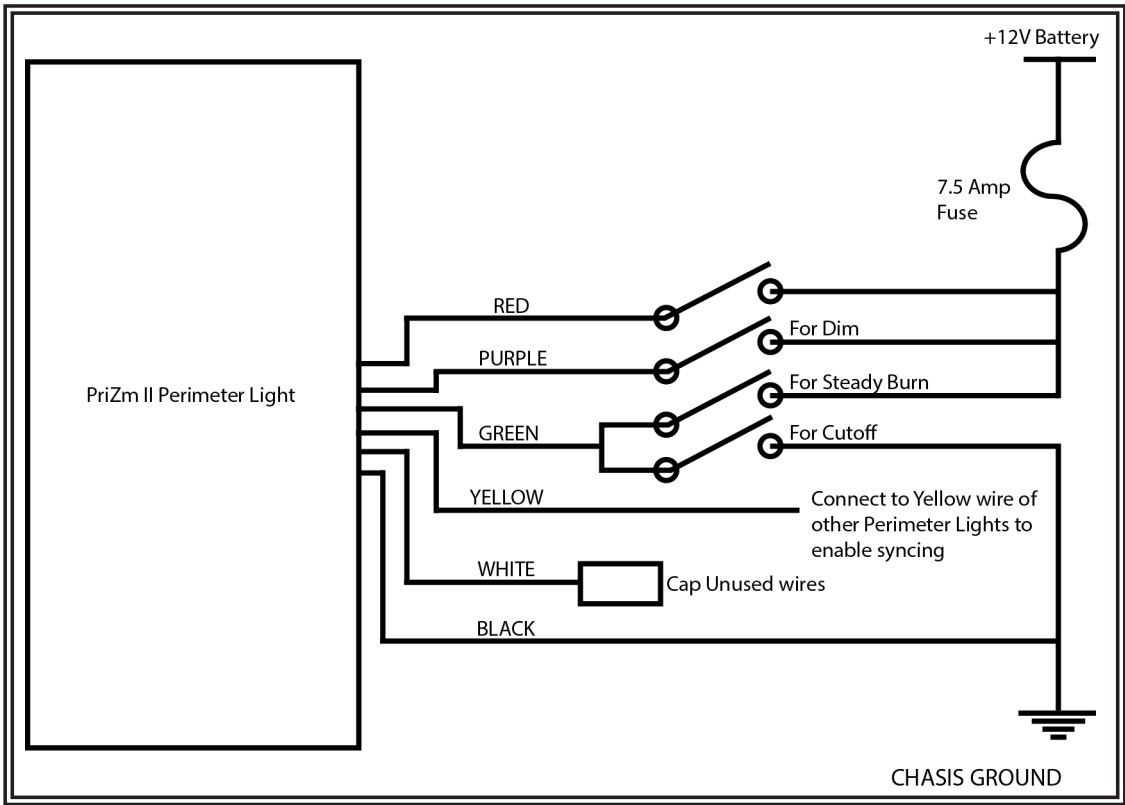

Figure 1

Device Operation:

Flash Pattern Selection - To select a different flash pattern, apply +12 VDC to the red wire and connect the black wire to the power supply ground. Touching the white wire to power supply ground for less than 1 second will change to the next pattern, for 1-2 seconds will change to the previous pattern, and over 2 seconds will reset to the default pattern (Pattern #1). During the programming process, the light head will turn certain lights on to indicate if it will go to the next, previous, or default pattern upon release of the white wire, See Table 2 for details. Cycle through the various patterns until the desired pattern is selected, Table 1 contains the available flash patterns. The unit will retain this pattern even when power is removed. For units that are flashed with an external control system such as a multiplexer or a flasher unit, the heads should be set to steady burn. It is suggested that all heads be set to the desired pattern at a workbench prior to installation.

Flash Patterns									
Pattern	Solid Color	Split Color	SAE J595				CA T13		
			Amber	Blue	Red	White	Amber	Blue	Red
1	CYCLE Ph1	CYCLE L/R	N/C	N/C	N/C	N/C	N/C	N/C	N/C
2	80 FPM NFPA QUAD Ph1	80 FPM NFPA QUAD L/R	Class 1/2*	Class 1	Class 1	Class 1	Class E	Class B	Class B
3	STEADY	STEADY	N/C	N/C	N/C	N/C	N/C	N/C	N/C
4	75 FPM SINGLE Ph1	75 FPM SINGLE L/R	Class 1/2*	Class 1	Class 1	Class 1	Class E	Class B	Class B
5	150 FPM SINGLE Ph1	150 FPM SINGLE L/R	Class 1/2*	Class 1	Class 1	Class 1	N/C	N/C	N/C
6	250 FPM SINGLE Ph1	250 FPM SINGLE L/R	N/C	N/C	N/C	N/C	N/C	N/C	N/C
7	75 FPM DOUBLE Ph1	75 FPM DOUBLE L/R	Class 1/2*	Class 1	Class 1	Class 1	Class E	Class B	Class B
8	150 FPM DOUBLE Ph1	150 FPM DOUBLE L/R	Class 1/2*	Class 1	Class 1	Class 1	N/C	N/C	N/C
9	75 FPM TRIPLE Ph1	75 FPM TRIPLE POP L/R	Class 1/2*	Class 1	Class 1	Class 1	Class E	Class B	Class B
10	150 FPM TRIPLE Ph1	150 FPM TRIPLE L/R	Class 1/2*	Class 1	Class 1	Class 1	N/C	N/C	N/C
11	75 FPM QUAD POP Ph1	75 FPM QUAD POP L/R	Class 1/2*	Class 1	Class 1	Class 1	Class E	Class B	Class B
12	150 FPM QUAD POP Ph1	150 FPM QUAD POP L/R	Class 1/2*	Class 1	Class 1	Class 1	N/C	N/C	N/C
13	70 FPM Five Ph1	70 FPM Five L/R	Class 1/2*	Class 1	Class 1	Class 1	Class E	Class B	Class B
14	150 FPM Five Ph1	150 FPM Five L/R	Class 1/2*	Class 1	Class 1	Class 1	N/C	N/C	N/C
15	MOD FLASH Ph1	MOD FLASH L/R	N/C	N/C	N/C	N/C	N/C	N/C	N/C
16	CYCLE Ph2	CYCLE Solid	N/C	N/C	N/C	N/C	N/C	N/C	N/C
17	80 FPM NFPA QUAD Ph2	80 FPM NFPA QUAD Solid	Class 1/2*	Class 1	Class 1	Class 1	Class E	Class B	Class B
18	STEADY	STEADY	N/C	N/C	N/C	N/C	N/C	N/C	N/C
19	75 FPM SINGLE Ph2	75 FPM SINGLE Solid	Class 1/2*	Class 1	Class 1	Class 1	Class E	Class B	Class B
20	150 FPM SINGLE Ph2	150 FPM SINGLE Solid	Class 1/2*	Class 1	Class 1	Class 1	N/C	N/C	N/C
21	250 FPM SINGLE Ph2	250 FPM SINGLE Solid	N/C	N/C	N/C	N/C	N/C	N/C	N/C
22	75 FPM DOUBLE Ph2	75 FPM DOUBLE Solid	Class 1/2*	Class 1	Class 1	Class 1	Class E	Class B	Class B
23	150 FPM DOUBLE Ph2	150 FPM DOUBLE Solid	Class 1/2*	Class 1	Class 1	Class 1	N/C	N/C	N/C
24	75 FPM TRIPLE Ph2	75 FPM TRIPLE POP Solid	Class 1/2*	Class 1	Class 1	Class 1	Class E	Class B	Class B
25	150 FPM TRIPLE Ph2	150 FPM TRIPLE Solid	Class 1/2*	Class 1	Class 1	Class 1	N/C	N/C	N/C
26	75 FPM QUAD POP Ph2	75 FPM QUAD POP Solid	Class 1/2*	Class 1	Class 1	Class 1	Class E	Class B	Class B
27	150 FPM QUAD POP Ph2	150 FPM QUAD POP Solid	Class 1/2*	Class 1	Class 1	Class 1	N/C	N/C	N/C
28	70 FPM Five Ph2	70 FPM Five Solid	Class 1/2*	Class 1	Class 1	Class 1	Class E	Class B	Class B
29	150 FPM Five Ph2	150 FPM Five Solid	Class 1/2*	Class 1	Class 1	Class 1	N/C	N/C	N/C
30	MOD FLASH Ph2	MOD FLASH Solid	N/C	N/C	N/C	N/C	N/C	N/C	N/C

* Solid Color Amber - Class 1, Split Color Amber - Class 2

Pattern Change Indication			
Light Head	Next Pattern Indication	Previous Pattern Indication	Default Pattern Indication
Solid Color (All sizes)	No lights on	All lights on	All lights flash once
Split Color (All sizes)	Right side on	Left side on	All lights flash twice

Flash Pattern Syncing - The flash patterns of multiple light heads may be synced together by simply connecting the yellow wires of all light heads to be synced. Up to 20 light heads may be synced in this fashion. All flash patterns that share the same flash rate may be synced together. For example, any 75 FPM flash pattern may be synced with any other 75 FPM flash pattern, etc. If this feature is not desired, the end of the yellow wire must be sealed or capped.

Flash Pattern Dimming - Flash patterns are dimmed when the purple wire is given a +12VDC signal. It is up to the installer to determine how to integrate this feature into their system. If this feature is not desired, the end of the purple wire must be sealed or capped.

Cutoff and Steady Burn Override - The green wire supports two different features, but only one may be used for a given light head. The green wire's default mode is Cutoff. To toggle between the two modes, connect the black and white wires to ground. Apply +12VDC to the red wire. The light head will flash once and remain off until the white wire is removed from ground. This indicates that the mode has been successfully changed.

NOTE: These two features require a different signal to activate them. Cutoff is activated by a ground signal, and Steady Burn Override is activated by a +12VDC signal.

Cutoff - Allows a ground input signal to the green wire to cut off the whole light on solid-color 3x7, 4x6 and 7x9 light heads, or the right side of the light head on left/right spit color light heads. This is useful for NFPA vehicles that need to cut off their white lights when blocking right-of-way. Upon removal of the ground signal, the current flash pattern will resume.

Maintenance:

The lens is field removable for cleaning and replacement. Remove the lens by unscrewing the four mounting screws. Use mild detergent, warm water and a soft cloth to clean both surfaces of the lens. Use of any other chemicals may void product warranty. Thoroughly dry before reinstalling.

Replacement Parts:

3X7		4X6		7X9	
LENS & LENS GASKET		LENS & LENS GASKET		LENS & LENS GASKET	
CR0005	RED	CR0014	RED	CR0023	RED
CR0006	AMBER	CR0015	AMBER	CR0024	AMBER
CR0007	BLUE	CR0016	BLUE	CR0025	BLUE
CR0008	CLEAR	CR0017	CLEAR	CR0026	CLEAR
LENS		LENS		LENS	
CR0009	RED	CR0018	RED	CR0027	RED
CR0010	AMBER	CR0019	AMBER	CR0028	AMBER
CR0011	BLUE	CR0020	BLUE	CR0029	BLUE
CR0012	CLEAR	CR0021	CLEAR	CR0030	CLEAR
LENS GASKET		LENS GASKET		LENS GASKET	
CR0013		CR0022		CR0031	
T07919		T07920		T07921	

Installation Dimensions:

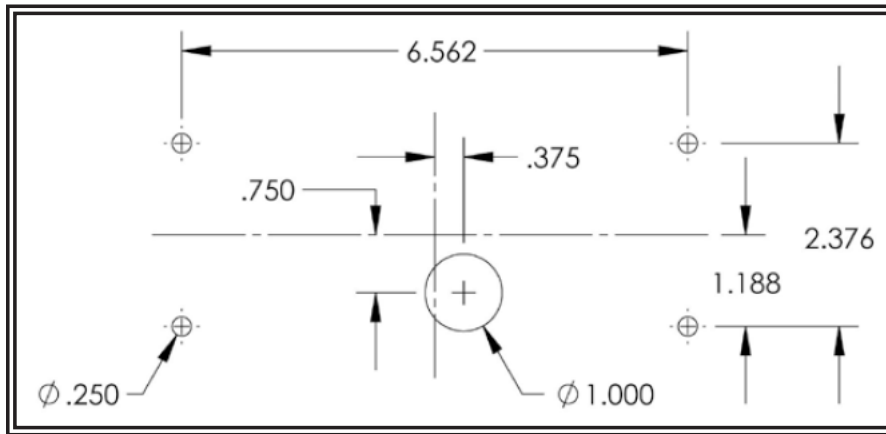

Figure 2

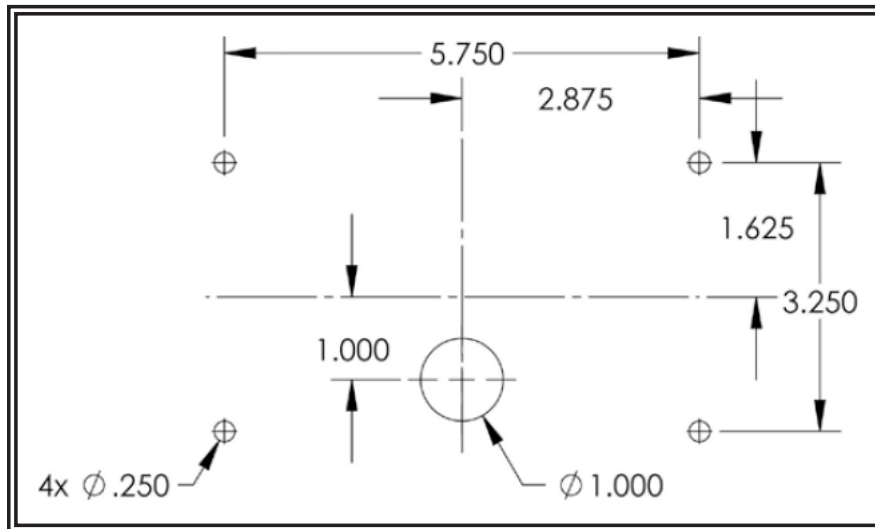

Figure 3

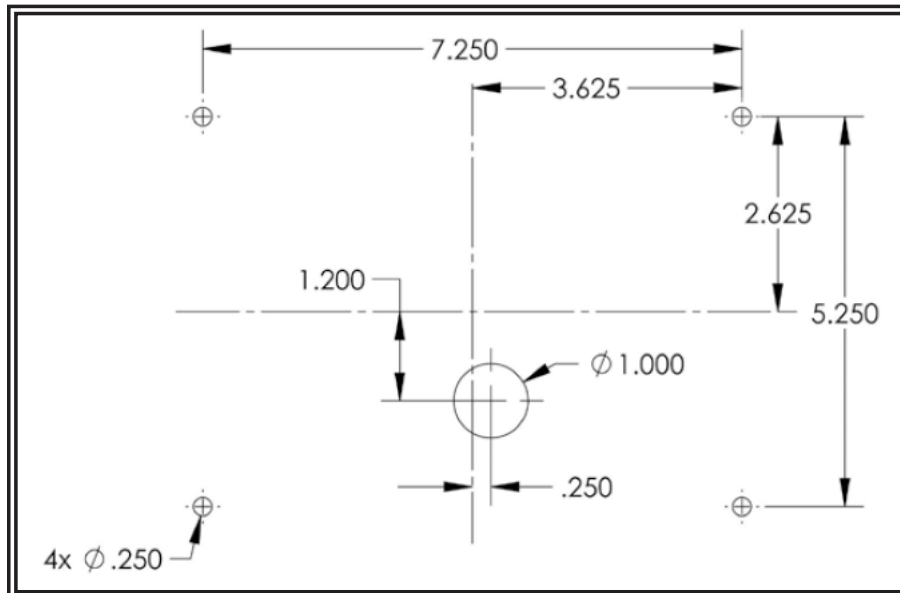

Figure 4

Notes:

Warranty:

Manufacturer Limited Warranty Policy:

Manufacturer warrants that on the date of purchase this product will conform to Manufacturer's specifications for this product (which are available from the Manufacturer upon request). This Limited Warranty extends for Sixty (60) months from the date of purchase.

DAMAGE TO PARTS OR PRODUCTS RESULTING FROM TAMPERING, ACCIDENT, ABUSE, MISUSE, NEGLIGENCE, UNAPPROVED MODIFICATIONS, FIRE OR OTHER HAZARD; IMPROPER INSTALLATION OR OPERATION; OR NOT BEING MAINTAINED IN ACCORDANCE WITH THE MAINTENANCE PROCEDURES SET FORTH IN MANUFACTURER'S INSTALLATION AND OPERATING INSTRUCTIONS VOIDS THIS LIMITED WARRANTY.

Exclusion of Other Warranties:

MANUFACTURER MAKES NO OTHER WARRANTIES, EXPRESS OR IMPLIED. THE IMPLIED WARRANTIES FOR MERCHANTABILITY, QUALITY OR FITNESS FOR A PARTICULAR PURPOSE, OR ARISING FROM A COURSE OF DEALING, USAGE OR TRADE PRACTICE ARE HEREBY EXCLUDED AND SHALL NOT APPLY TO THE PRODUCT AND ARE HEREBY DISCLAIMED, EXCEPT TO THE EXTENT PROHIBITED BY APPLICABLE LAW. ORAL STATEMENTS OR REPRESENTATIONS ABOUT THE PRODUCT DO NOT CONSTITUTE WARRANTIES.

Remedies and Limitation of Liability:

MANUFACTURER'S SOLE LIABILITY AND BUYER'S EXCLUSIVE REMEDY IN CONTRACT, TORT (INCLUDING NEGLIGENCE), OR UNDER ANY OTHER THEORY AGAINST MANUFACTURER REGARDING THE PRODUCT AND ITS USE SHALL BE, AT MANUFACTURER'S DISCRETION, THE REPLACEMENT OR REPAIR OF THE PRODUCT, OR THE REFUND OF THE PURCHASE PRICE PAID BY BUYER FOR NON-CONFORMING PRODUCT. IN NO EVENT SHALL MANUFACTURER'S LIABILITY ARISING OUT OF THIS LIMITED WARRANTY OR ANY OTHER CLAIM RELATED TO THE MANUFACTURER'S PRODUCTS EXCEED THE AMOUNT PAID FOR THE PRODUCT BY BUYER AT THE TIME OF THE ORIGINAL PURCHASE. IN NO EVENT SHALL MANUFACTURER BE LIABLE FOR LOST PROFITS, THE COST OF SUBSTITUTE EQUIPMENT OR LABOR, PROPERTY DAMAGE, OR OTHER SPECIAL, CONSEQUENTIAL, OR INCIDENTAL DAMAGES BASED UPON ANY CLAIM FOR BREACH OF CONTRACT, IMPROPER INSTALLATION, NEGLIGENCE, OR OTHER CLAIM, EVEN IF MANUFACTURER OR A MANUFACTURER'S REPRESENTATIVE HAS BEEN ADVISED OF THE POSSIBILITY OF SUCH DAMAGES. MANUFACTURER SHALL HAVE NO FURTHER OBLIGATION OR LIABILITY WITH RESPECT TO THE PRODUCT OR ITS SALE, OPERATION AND USE, AND MANUFACTURER NEITHER ASSUMES NOR AUTHORIZES THE ASSUMPTION OF ANY OTHER OBLIGATION OR LIABILITY IN CONNECTION WITH SUCH PRODUCT.

This Limited Warranty defines specific legal rights. You may have other legal rights which vary from jurisdiction to jurisdiction. Some jurisdictions do not allow the exclusion or limitation of incidental or consequential damages.

Product Returns:

If a product must be returned for repair or replacement*, please contact our factory to obtain a Return Goods Authorization Number (RGA number) before you ship the product to Code 3®, Inc. Write the RGA number clearly on the package near the mailing label. Be sure you use sufficient packing materials to avoid damage to the product being returned while in transit.

*Code 3®, Inc. reserves the right to repair or replace at its discretion. Code 3®, Inc. assumes no responsibility or liability for expenses incurred for the removal and /or reinstallation of products requiring service and/or repair.; nor for the packaging, handling, and shipping; nor for the handling of products returned to sender after the service has been rendered.



10986 North Warson Road, St. Louis, MO 63114 USA
Technical Service USA (314) 996-2800
c3_tech_support@code3esg.com
CODE3ESG.com