

FLOYD

Sofa

Components

6x Legs

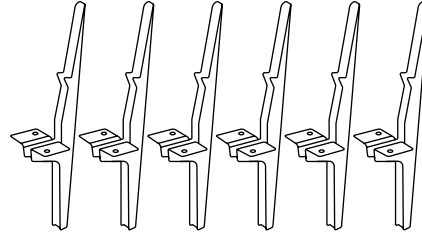

1x Floyd Tool

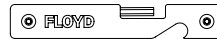

12x Knobs



A

12x Pins



B

12x Bolts



C

Components Cont.

Three-Seater

1x Back Panel

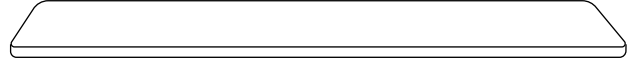

1x Back Panel

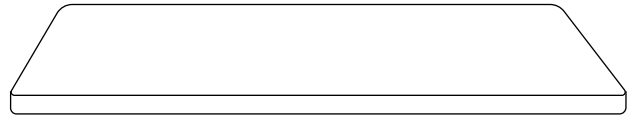

Two-Seater

1x Back Panel



1x Seat Panel

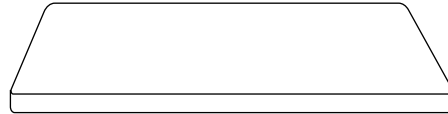

2x Arm Panels

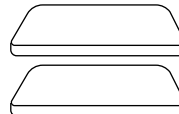

Components Cont.

Cushions

Seat Cushions

3x

Three-Seater



2x

Two-Seater



Arm Cushions

2x

Three-Seater



2x

Two-Seater



Back Cushions

3x

Three-Seater



2x

Two-Seater



Components Cont.

Chaise

4x Chaise Legs

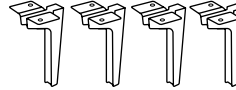

12x Knobs



A

2x Connector Plates



1x Chaise Panel

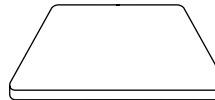

1x Chaise Cushion



1

Align the legs

Begin with the main seat panel. Flip the panel up onto its front edge (We recommend doing this on a rug or the packaging it came in to protect the edge & your floor). **We also recommend to have a friend help hold up the panel while you attach the legs.**

Slide a leg onto the end of each crossbar on the bottom of the seat panel. Insert two of the pins (B), one from each side, into the holes on the leg, all the way through the crossbar.

Note: The pins should click into place – make sure they go all the way through both sides of the leg.

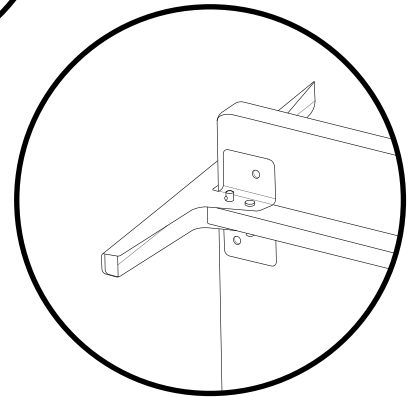
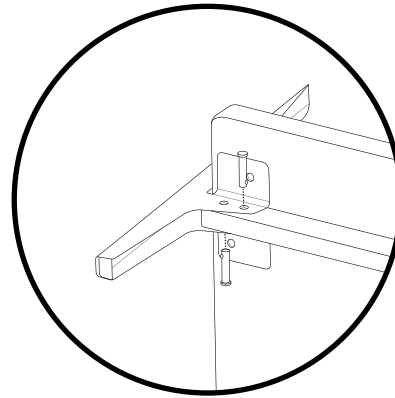
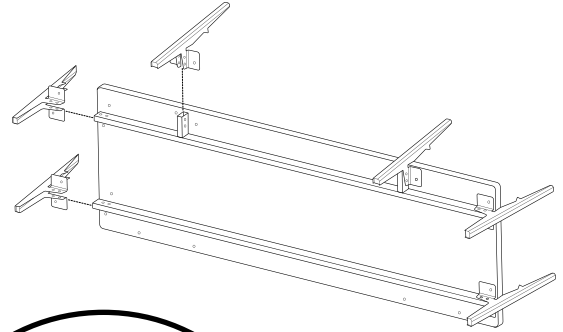

2

Secure the legs

On the same leg, insert two knobs (A) into the holes on the bottom of the plate, and turn to the right to tighten.

Repeat the last two steps for the remaining 5 legs in the same order – pins first, then fasteners.

After all six legs are securely attached with both the pins and knobs, have your friend help flip the seat panel onto its legs.

Take one of the arm panels and place it on the small ledges of the side legs.

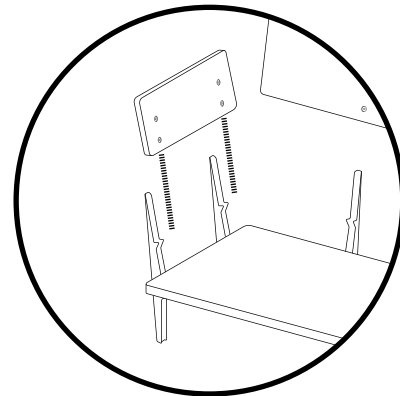
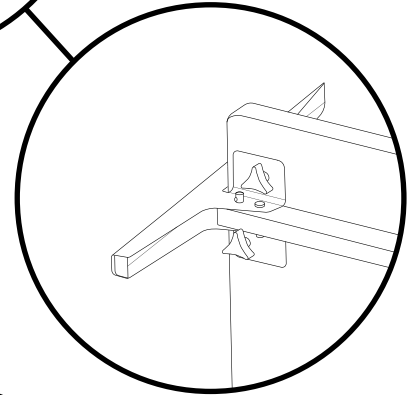
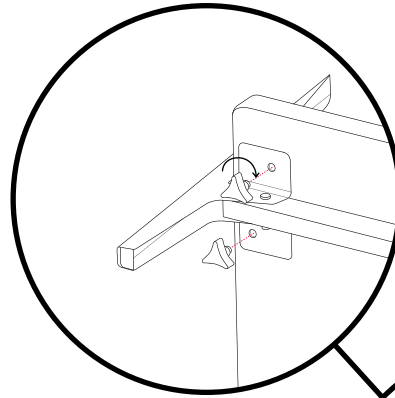

3

Secure the panels

Once resting on the ledge, align the holes in the panel with the holes in the legs. Insert a bolt (C) through each hole in the panel into the hole in the leg. Begin turning by hand to make sure the bolt is tightening. Then use the hex key on the Floyd Tool to fully tighten the bolt.

Attach the other arm panel and the back panel in the same way. Make sure all panels are securely attached before adding cushions.

When all panels are attached your sofa should look like this. Now you're ready for cushions!

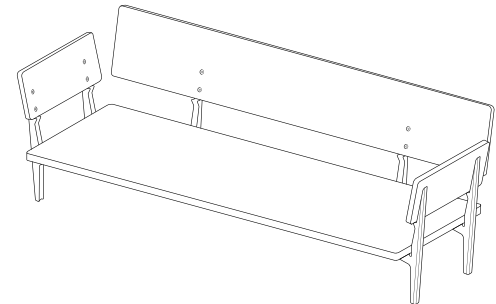
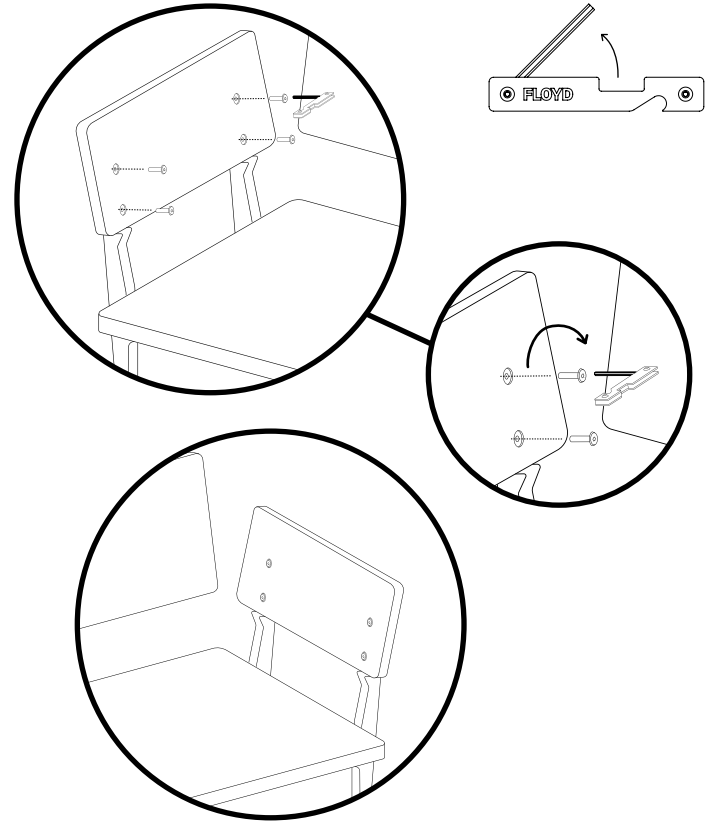

4

Insert the cushions

Put the cushions on the frame like this. The largest cushions are for the seat, and the slightly smaller, for the back. The smallest two cushions are for the arms.

Note: The zipper on the seat cushions should face the back.

If you don't have a chaise, that's it - you're done!

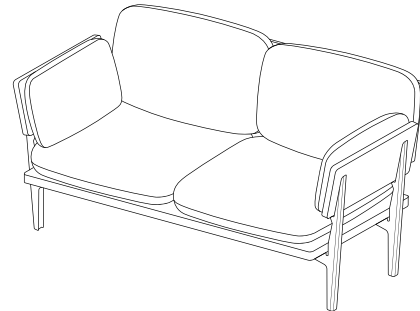
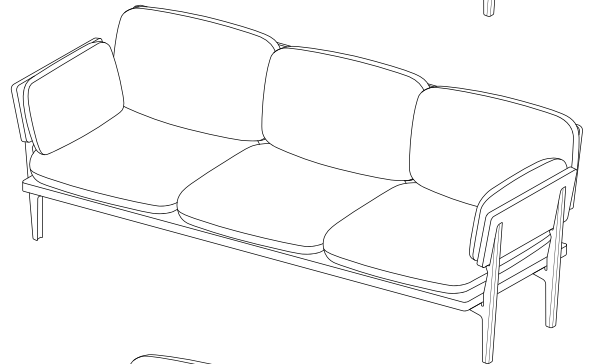
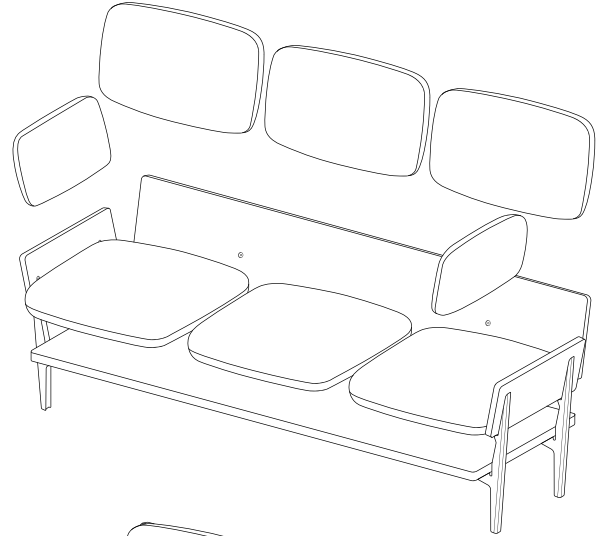

5

Assemble the chaise

If you do have a chaise, here's how to set it up.

Begin by attaching the four legs to the bottom of the chaise panel with the knobs (We recommend doing this on a rug or the packaging it came in to protect the surface of the panel).

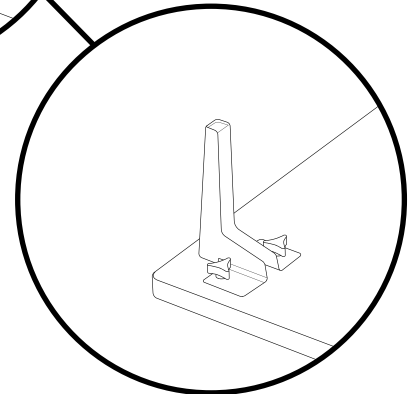
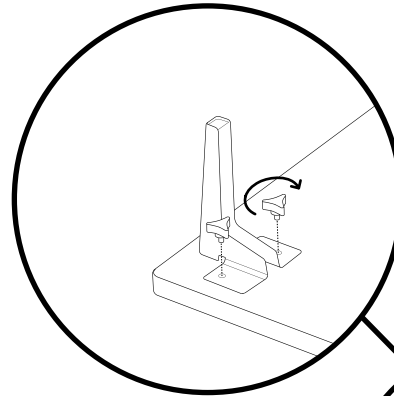
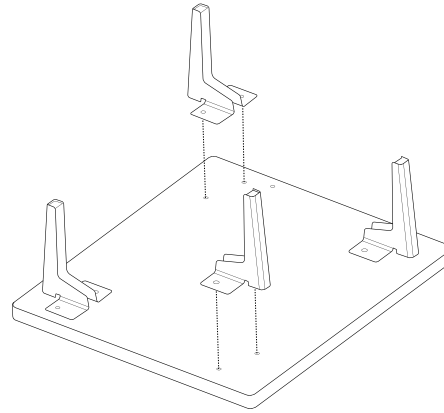

6

Attach the chaise

When all four legs are attached, flip over the chaise panel.

Place the chaise panel on the side of the sofa where you want to attach it (it can go on either the left or right side, and you can always switch it later!)

Take the two chaise connector plates and attach them to the bottom of chaise panel with two knobs.

The side of the plate with the longer slotted hole should attach to the bottom of the main sofa seat panel. Use the last two knobs to fasten the chaise connector plates to the main seat panel.

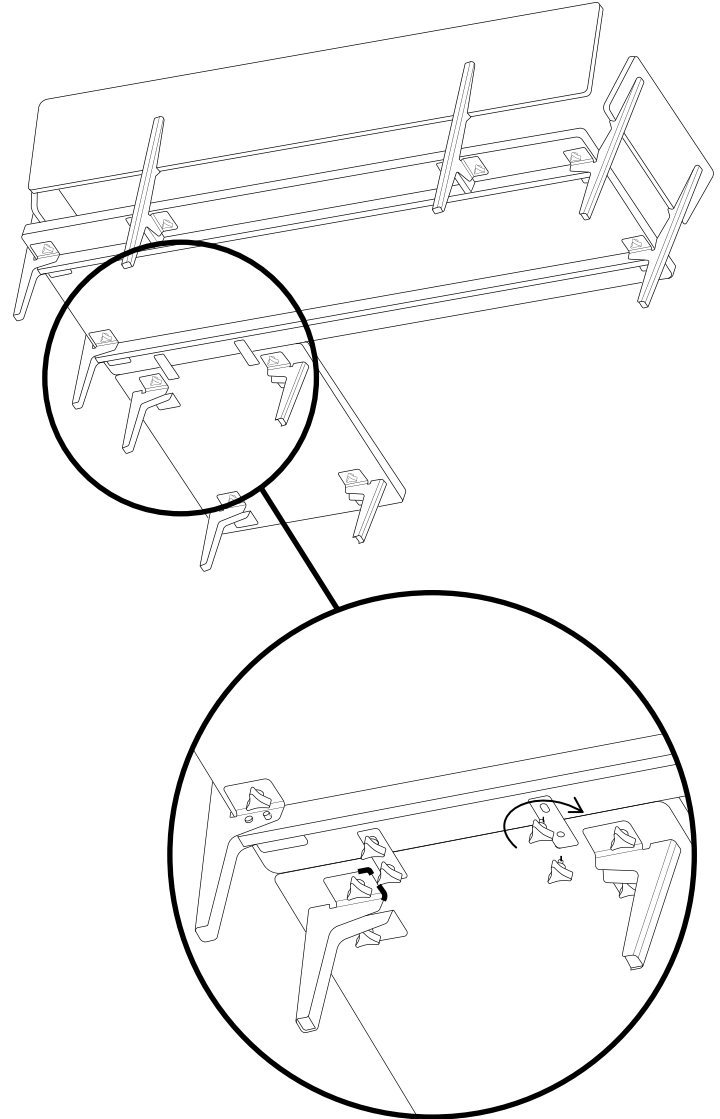

7

All done!

If you have the chaise, place the longer chaise cushion on that side of your sofa.

Note: The chaise cushion should be placed so that the zipper pull is at the front of the sofa.

**Now, don't be shy—
we'd love to see your
sofa's new home!**

**@floyddetroit
#thefloydsofa**

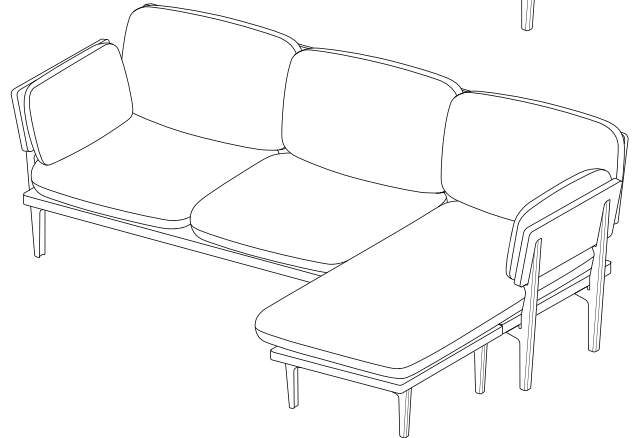
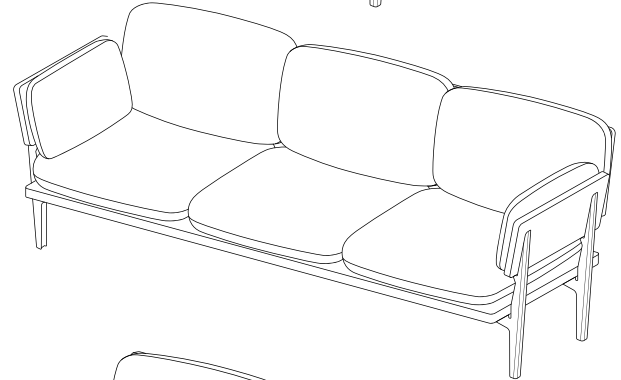
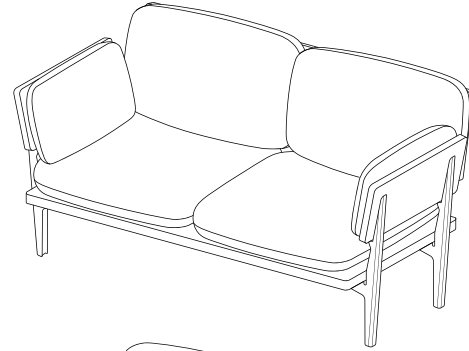

⚠ WARNING

ASSEMBLY:

Use extra caution when assembling and have someone assist you. Do not change the specifications or modify this product or use for any other purpose beyond its intended use as a sofa. Incorrect assembly can cause product to fail and cause personal injury. Double check that all fasteners are tightened and all pins are securely in place before use. Ensure that the back and arm panels are securely fastened to the legs and cushions are in place before using. Use caution and have someone assist you when assembling and flipping over the sofa during assembly.

USAGE:

Remove all packaging before first use. Check periodically that all fasteners and pins are securely tightened and in place. Be aware that fasteners may become loose with prolonged use. The legs, panels, cushions, and hardware components are only intended as shown for use with the Floyd Sofa. The sofa is only meant for use indoors. The sofa has a tested capacity of 300lbs per seat. Loading it with more than this can cause personal risk and injury. Standing on, jumping on, or sitting on the arm or back panels may cause personal risk or injury.

CHILDREN:

Exercise caution when children are near or sitting on sofa. Do not allow children to play under sofa or jump on sofa. There is a risk of injury from not following these warnings. Keep all packaging and parts away from children. There is a risk of choking and suffocation.

CARE:

GENERAL SPILLS:

For mild spills, blot with a paper towel. For tougher spills, use a mild soap and water mix. To make the soap and water mixture, take 1 teaspoon of a liquid detergent such as Tide and mix it with 16 oz. of water in a bowl or plastic container – do not over wet the material. Cushion covers should not be removed and laundered – doing so could negate the stain-resistant technology.

CONTACT

Have a question,
comment, or suggestion?
Just want to say hi?

hello@floydhome.com

FLOYDHOME.COM

Visit the Floyd Shop

The Floyd Shop
1948 Division St. Suite 101
Detroit, MI 48207

FLOYD

FLOYDHOME.COM