

Large working plane

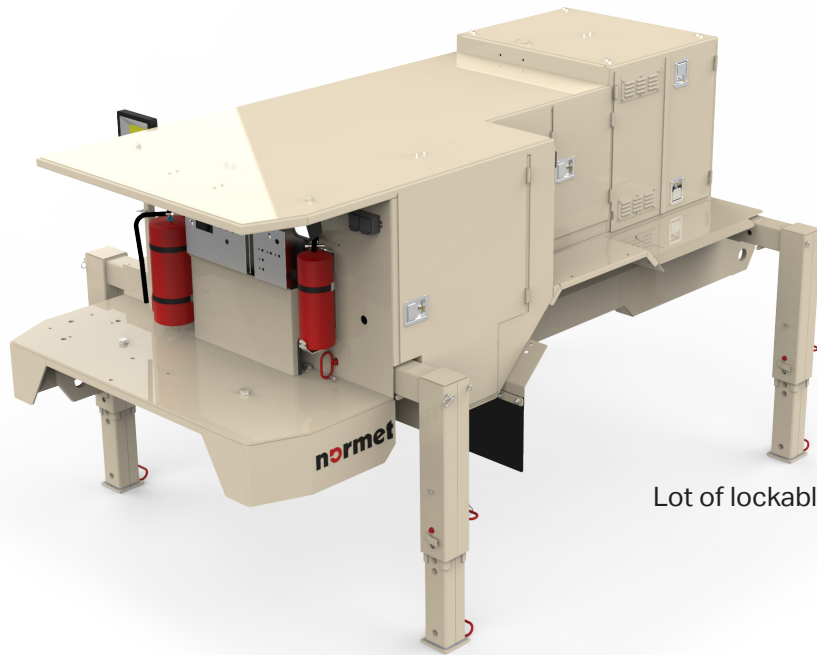

Portable workshop
Can be used individually

Lot of lockable storage room

TECHNICAL SPECIFICATION

Arc welding equipment with welding rods

Working space with bench vice

Standard toolset including:

- Spanner set with ring spanners (mm and inch)
- Socket wrench set (mm and inch)
- Screw driver set
- Drill and drill bit set
- Other tools such as hammers, cutters, pliers, saws, knives, gauges, lubrication gun and bottle jack
- Power tools with extra grinding wheels
- Pressurized air bottle and reel

ADDITIONAL EQUIPMENT

- Aggregate for power tools
- Gas welding & cutting equipment
- Gas bottles (country specific safety regulations have to be checked case by case)

DIMENSIONS

Length	3700 mm
Width	2010 mm
Height	1670 mm
Height with SF 060 / MF 100	2000 mm / 2100 mm
Weight	2100 kg

DIMENSIONAL DRAWINGS

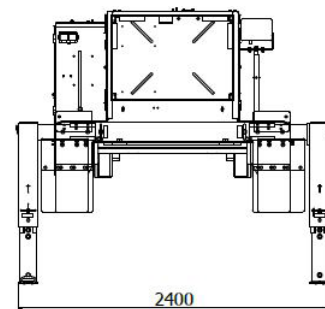
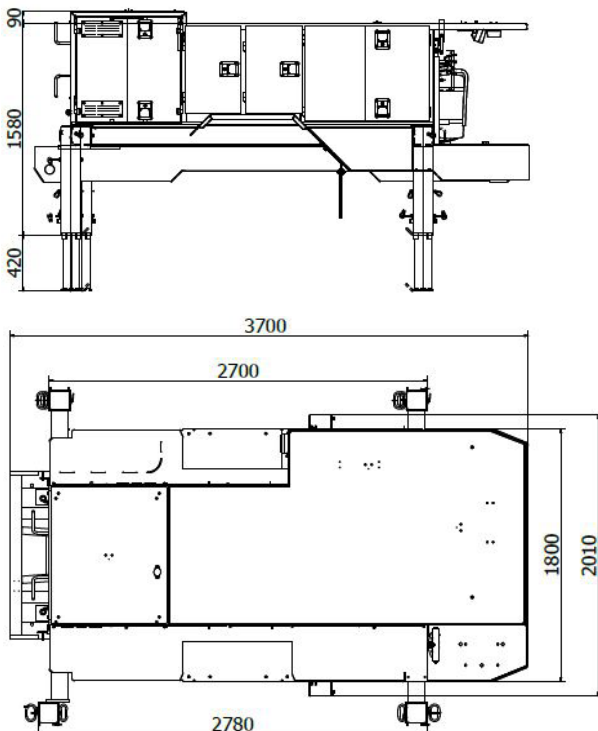

Normet reserves the right to change this specification without further notice.