



# Charmec MF 605 D(V) SE&LE



Normet reserves the right to change  
this specification without further notice

Pictures may include options and additional equipment.

## INTRODUCTION

Charmec MF 605 D(V) SE&LE are sister models having both 6-tons payload for center mounted underground bulk emulsion kits.



Short End version is agile and can perform well both in development and production charging.

Long End version has more room to utilize maximum payload which means up to 4-tons of bulk emulsion brought to site at once.



This considerably reduces the need for driving back and forth to explosives warehouse, which increases the process efficiency whilst keeping machine fit as constant driving is experienced to be the main reason for charging equipment break downs. Less driving, higher productivity, and less machine breakdowns like basket boom wall contacts.

Capable mine proof NBB3S-series basket boom has reach and coverage from 4x4 m to 8x8 m tunnel envelope covering bulk of development tunnel needs in mining.

Normet reserves the right to change this specification without further notice

### POWER TRAIN

M-series units have powerful 4-cylinder liquid cooled turbo-charged engines, which power range is between 110-121 kW, depending of the selected engine model. Available emission standards are Tier 3 / Stage IIIA and Stage V that provide clean and efficient operation.

Machine is equipped with Dana hydrodynamic transmission and planetary type axles which have hydraulically powered dual-circuit oil immersed multidisc service brakes. Moreover, axles have spring applied hydraulically released fail-safe -type parking/safety brake.

### SAFETY AND USABILITY

Vehicle has an optional front axle suspension system, which improve safety, driving comfort and increases component lifetime.

Normet's FOPS and ROPS approved safety cabin provides superior visibility and comfortable compartment for the driver and the passenger. Cabin controls are easy and ergonomic to use, and the multifunctional display (MID) provides driving information (speed, RPM, temperatures, safety warnings & alarms etc.), which can be recorded for further analysis. Enclosed cabin provides low noise level ensuring safe and comfortable driving.



Pictures may include options and additional equipment.

Emulsion charging system is designed to be safest possible having given extra care to electric current groundings, fire safety and safety when working in vicinity of face wall.

Two handheld fire extinguishers are standard and fire suppression system for diesel engine is automatic or manual having actuating points in all operating places.



Person lifting basket has latest safety features like design according to prevailing standards and safety roofs tested through FOPS level II criteria.

Electric system is designed for harsh underground environment. System consists of self-extinguishing wire harnesses with tinned wires, water tight conduits and all exposed components are minimum IP65 protection class. In addition, vehicle layout allows easy access to all service points, all daily checks can be done from the ground level.

## PRODUCTIVITY



Power hose pusher with Normet emulsion charging hoses provides excellent reach to vertical production charging holes.

Direct hydraulic operated hose handling system is simple and reliable and in case exact hose retraction speed is required electrically controlled system can be provided.

Development charging can be mechanized by using face charging hose reel which will extract and retract charging hose mechanically with extreme speed accuracy.



Installation of external emulsion unit can be provided as a service which makes possible customer to receive unit ready to work.

## TECHNICAL SPECIFICATION

### CHARGING SYSTEM

Process platform on middle of unit

Max. load 6000 kg

Center of gravity shown in the dimensional picture

Process platform size:

- Short end, 800 x 2000 mm
- Long end, 1600 x 2000 mm
- Readiness for external emulsion unit:
  - Basic upfit for external emulsion charging system  
18 x 1,5 mm<sup>2</sup> cable between charging system and basket
  - Hydraulic hoses for charging system:  
pressure 3/4", tank 1", leak 1/4", LS 1/4"
  - 24 VDC supply for charging system
  - Readiness according customer specification

Detonator box lining:

- Antistatic rubber lining
- IME SLP 22 lining

### NBB3S BASKET BOOM

2-operator basket

Lifting capacity (without optional equipment) 500 kg

Max. lifting height and wall coverage specified in dimensional drawing

Automatic levelling of basket

Start/stop from basket

Battery operated emergency lowering system

Basket installation position:

- Regular
- Hanging (reduce max. lifting height 500 mm)

Basket:

- Standard 2-operator basket
- Front gate 2-operator basket
- Short 2-operator square tube basket
- Short 2-operator open profile basket

Person lifter safety system:

- Dangerous movement preventing system (mandatory in NAP, NAS, CE area)
- Dangerous movement warning system with overload monitoring
- Dangerous movement warning system without overload monitoring

### ENGINE AND TRANSMISSION

- **Deutz TCD 2013 L4, 120 kW/2300 rpm, Tier 3 / Stage IIIA approved**

Exhaust system for Deutz engine:

- Catalytic exhaust gas purifier and muffler
- Diesel particulate filter (DPF)

Fuel tank capacity 110 l

#### **Dana 24000 series powershift transmission**

3 speeds forward and reverse

4-wheel drive

Manual gear selector

- **Mercedes-Benz OM 904 LA, 110 kW/2200 rpm, with engine & exhaust brakes, Tier 3 / Stage IIIA approved**

Exhaust system for MB engine:

- Catalytic exhaust gas purifier and muffler
- Diesel particulate filter (DPF)

Fuel tank capacity 110 l

#### **Dana 24000 series powershift transmission with lock-up**

3 speeds forward and reverse

4-wheel drive

Gear selector:

- Manual
- Automatic

- **Cummins B4.5, 121 kW/2500 rpm with exhaust brake, Stage V approved**

Requires diesel exhaust fluid (DEF) and Ultra-low sulphur diesel (ULSD)

Diesel particulate filter (DPF)

Selective catalytic reduction (SCR)

DEF tank capacity: 19 l

Fuel tank capacity: 105 l

#### **Dana 24000 series powershift transmission with lock-up**

3 speeds forward and reverse

4-wheel drive

Gear selector:

- Manual
- Automatic

## PERFORMANCE

Tramming speed (horizontal):	
Deutz	26 km/h
Mercedes-Benz	26 km/h
Cummins	26 km/h
Lateral gradient for tramming (continuous)	4°
Longitudinal gradient for tramming (continuous)	9°
Lateral gradient for operation	3°

## AXLES AND BRAKES

- Load end axle:  
Dana 123 series fixed
- Engine end axle:  
Dana 123 series
- +/- 8° oscillation
    - Hydro-pneumatic suspension and +/- 8° oscillation
- Service brake: hydraulically powered dual-circuit oil immersed multidisc brakes in both axles
- Safety/Parking brake: spring applied hydraulically released fail-safe -type brake

## TYRES AND RIMS

- Tyres:
- Nokian Tyres 12.00–20”
    - Bridgestone 12.00–20”
- Rims:
- Standard rims
    - NDT inspected rims

## STEERING

Orbitrol type hydraulic frame steering

Frame articulation +/- 40°

## HYDRAULIC SYSTEM

- Variable displacement pump system 190 bar at 2200 rpm:
- Single pump for carrier and process 135 l/min
    - Separated pumps for carrier 95 l/min and for process 135 l/min
- Hydraulic oil tank capacity 110 l

## 24 VDC ELECTRICAL SYSTEM

- Mechanical main switch in battery box
- LED driving and indicator lights
- LED work lights on cabin
- LED work lights in basket
- LED side lights (left/right):
- White / White
    - Green / Red
    - Red / Green
- Warning LED light:
- Color
- Amber
    - Blue
    - Red
    - Green (n/a with rotating light pattern)
    - White (n/a with rotating light pattern)
- Light pattern
- Strobe
    - Rotating

## DRIVER'S COMPARTMENT

- Cabin type:
- Open cabin FOPS/ROPS approved
    - Enclosed cabin FOPS/ROPS approved with sliding rear window
- Driver's seat and seat belt:
- Air suspended T-back seat with 3-point seat belt
    - Air suspended heavy duty seat with 3-point seat belt
- Seat belt safety interlock for driver:
- Warning indicator in display
  - Safety brake application
- Cabin door interlock switches with safety brake application
- Passenger's seat:
- T-back seat with 3-point seat belt
    - Heavy duty seat with 3-point seat belt
    - 2 person seat with fixed lap seat belts
- Throttle and brake pedal layout:
- Front and side facing pedals with seat swivel
    - Front facing pedals
- Gear lever side:
- On right side of the steering wheel
    - On left side of the steering wheel

## MACHINE CONNECTIVITY

- Machine connectivity hardware (WLAN/3G/4G/LTE)
- Data lifetime license (Include connectivity hardware)
- Analytics lifetime license  
(Include connectivity hardware and data lifetime license)

## TECHNICAL DOCUMENTATION

Standard documents:

Instruction manuals, hard copy 2 pcs:

- English
- Russian
- One of destination EU languages

Spare parts manuals, hard copy 2 pcs:

- English
- Russian

PDF manuals on USB-stick 2 pcs, includes instruction and spare parts manuals

Additional documentation:

- Extra hard copies of manuals
- Extra PDF manuals
- LinkOne WebView electronic manuals
- Other than standard language manuals

## OTHER

Powder extinguisher:

- 12 kg
- Ansul Sentry

Number of extinguishers:

- 2
- 3

Painting and taping:

- Standard painting and taping
- Painting and taping according to customer specifications

Extendable support legs at the load end

Front and rear grounding straps:

- Flat cable
- Chain

Text labels in:

- En/Ru/One of destination EU languages
- Other language

Measurements:

- Noise
- Vibration
- Emissions

## ACCESSORIES

### PROCESS PRODUCTIVITY

- Engine end support legs
  - Installation service for external emulsion charging system
    - CE-marking for installation of external emulsion charging system
  - Compressed air inlets with water separator on carrier
  - Compressed air outlet and oil lubrication unit in basket
  - Water inlet with filter and pressure regulator
  - Electrically controlled face charging reel and valve with face charging hose 25 x 20 mm, 15 m (n/a with production charging and hanging basket)
  - Production charging (n/a with face charging reel and hanging basket)
    - Direct hydraulic controlled hose pusher
    - Electrically controlled hose pusher and valve
- Hose diameter and length (includes 4 pcs of groove pulleys)
- Without hose
  - 32 x 23 mm, 50 m
  - 40 x 31 mm, 50 m
- Additional groove pulleys, 4 pcs
- 28 mm
  - 32 mm
  - 40 mm
- Hose guides
- Hose guide for upward production charging
  - Extension for hose upward hose pusher
  - Diverting pulley for downward production charging
- Charging hose reel material
- Steel
  - Stainless steel
- Production charging reel coupling size
- 1 ½" rotary coupling and tube
  - 1" rotary coupling and tube
- Onboard compressor
    - 2.6 m<sup>3</sup>/min
    - 0.45 m<sup>3</sup>/min
  - 230 l water tank above the cabin (Increased machine height 200 mm)
  - Hydraulically driven pressure washer with hose reel:
- |                      |          |
|----------------------|----------|
| Water pressure, max. | 180 bar  |
| Water flow, max.     | 30 l/min |
| Hose length          | 20 m     |
- Standard pressure washer
  - Stainless steel reel and rod
  - Extra oil cooler

- Electrical system:

#### Main supply voltage

##### Power supply for the electrical functions

- 50 Hz
  - 380 V (IEC)
  - 400 V (IEC)
  - 415 V (IEC)
  - 525 V (IEC)
  - 690 V (IEC)
  - 1000 V (IEC)
  - 1000 V (AS/NZS)
- 60 Hz
  - 440 V (UL/CSA)
  - 440 V (IEC)
  - 480 V, (460 V) (UL/CSA)
  - 600 V, (575 V) (UL/CSA)
  - 1000 V (UL/CSA)

Robust and abrasion-resistant mains voltage supply cable with PUR outer sheath:

Hydraulically driven reel with spooling device

Cable in / out reeling function from the cabin and near the reel

- With supply cable (excluding plug)
- Without supply cable (must be sourced and installed locally)

#### Pilot circuit

- No
- Yes

Hydraulic power pack 22 kW:

Single pump for carrier and process 90 l/min at 1500 rpm

Socket supply voltage:

- 220/230/240 V (no UL/CSA or AN/NZS approval)
- 110/120 V

### CARRIER PRODUCTIVITY

- Accessories for open cabin:
  - Protective grids
  - Windshield with wipers
- Accessories for enclosed cabin:
  - Audio system
  - Air conditioning with heating
  - Heated mirrors
  - 12 V, 18 A power supply in cabin with socket and connector
  - Deutch connector for 24 V, 10 A for external power supply
  - Auto engine shutdown during idling
  - Engine shutdown delay
  - Inlet plug for jump start
  - Block heater with interior heater and battery charger 230 V (Interior heater available with enclosed cabin)

- Block heater with interior heater, battery charger, hydraulic oil and filter heaters 400 V  
(Interior heater available with enclosed cabin)
- Fuel operated pre-heater
- Fast fuel filling system
- Hand pump for filling of hydraulic tank
- Fluid evacuation panel with sampling points
- Automatic lubrication system
- Reversing camera:
  - 1 camera, 1 display
  - 3 cameras, 2 displays
  - 4 cameras, 3 displays.
 OACR/VCR system with recording device with 72 hour memory
- Spare rim and tyre
- Toolbox and maintenance tools
- Stainless steel box for equipments  
(n/a with electrical system)
- Interior cooling fan
- Wax tape for electric connectors

## SAFETY

- Cabin door puddle lights
- Extra warning LED light (From the options below it is possible to choose 1-2 combinations)
  - Color
    - Amber
    - Blue
    - Red
    - Green (n/a with rotating light pattern)
    - White (n/a with rotating light pattern)
  - Light pattern
    - Strobe
    - Rotating
- Fire extinguisher system, 3 point activation  
(basket, cabin, rear frame)
  - Dry chemical  
Ansul A-101
    - Manual
    - Automatic, Checkfire 110
  - Liquid agent  
Fogmaker (Automatic)
- Gear lockout for third gear
- Engine end safety rails and ladder  
(n/a with electrical system)
- Pump for brake release
  - Electric pump
  - Hand pump
- Redundant brake monitoring system
- Hydraulic pressure monitoring kit
- Methane monitoring system
- Protection guards for tunnel curtains
- Tyre pressure indicators
- Additional wide angle mirrors (n/a with heated mirrors)
- Warning triangles
- Flashlight with charger
- Hearing protectors
- Wheel chocks with brackets

## SAFETY BASKET BOOM

- Safety roof or bar on basket
  - Safety bar
  - Safety bar with hydraulic lift  
Reduces lifting capacity 60 kg
  - Safety roof with hydraulic lift  
Reduces lifting capacity 100 kg
  - Safety roof with hydraulic lift and slide  
Reduces lifting capacity 200 kg

**NOTE:** safety roofs and bar for the basket boom affect to the lifting capacity.

Accessories for basket boom:

- Boom suspension
- LED working lights on safety roof/bar
- Operator present: Foot pedal switch on basket
- Operator present: Spring loaded valve levers
- 24 V fan in the basket



## SERVICES

### NORMET SERVICES

Our services cover the whole life cycle of your equipment. They include start-up and commissioning, genuine spare parts, upgrades & modifications, and remanufacturing, as well as rental and leasing offerings, and field services. We also offer improvement services such as operator training and process audits.

### SPARE PARTS

Genuine parts from Normet Services ensure that you always have the highest quality parts available to keep your equipment up and running. Depending on your needs, we can offer everything from individual parts to complete parts contracts, and our professionals around the world have the experience to ensure that you have the parts you need when you need them.

#### Initial spare parts package:

Available for 1000h of use\*. Includes periodical service, most common wearing parts and most critical safety parts.

#### Spare parts packages made for customer needs:

Available based on hours of use\*. Includes periodical service, most common wearing parts and most critical safety parts.

\* Recommendations are based on average hours – can vary a lot depending on work site conditions.

### UPGRADES AND MODIFICATIONS

Our Upgrades and Modifications services are designed to ensure the economical, efficient and purposeful performance of your equipment over its entire life cycle. A service provided by a reliable OEM like Normet ensures the safety and performance of your equipment. Normet Upgrades and Modifications save you both time and money, while delivering the high quality you expect from us.

### SERVICE CONTRACTS



With a service agreement, Normet manages your fleet with guaranteed availability and agreed costs, giving you transparency for your life cycle costs, annual operational budget and fleet uptime. This lets you focus on your core operations. Each service agreement is built and customized to meet the individual customer's needs from our portfolio of services. Depending on the level of service agreement you need, you can choose anything from basic technical support for an individual machine all the way up to services for your entire fleet, as well as process performance. The service levels we offer are:

- Parts Availability
- Fleet Support
- Fleet Availability
- Process Performance

The content of a service level can be tailored to meet your particular requirements.

### TRAINING SERVICE

Our Training Services are available for you and your operators throughout the equipment lifecycle and they include:

				
	Operation & Maintenance	Spraying	Charging	Scaling
ADVANCED	Advanced fault diagnostics & troubleshooting	Concrete chemicals, testing and preparing for EFNARC-certificate test		
INTERMEDIATE	Troubleshooting training Foundations of electrics, hydraulics and mechanics NorSmart	Advanced training in concrete spraying Economics of concrete spraying	Advanced training in explosives Economics of charging	Advanced training in scaling Economics of scaling
BASIC	Operation and Maintenance Training Basic Product Training	Basic understanding of concrete spraying	Basic understanding of charging	Basic understanding of scaling
LEVEL	SERVICE	PROCESS KNOWLEDGE		

# START-UP AND COMMISSIONING

## 1. OPERATOR TRAINING

	Start-up training	Commissioning
<b>1.1 Classroom training</b>		
General introduction and operation of machine	Basic	No classroom training included in commissioning
Safety instructions	Basic	
Use of manuals	Basic	
Technical introduction of equipment	Basic	
Hands-on service and pre-operation checks	Basic	
Controls and driving (starting, driving, stopping, parking)	Basic	
<b>1.2 Practical training</b>		
Pre-operation checks	Basic	Introduction
Driving, starting, stopping, parking	Basic	Introduction
Preparing the machine for specific operation conditions	Basic	Not covered
Operation	Basic	Introduction
Washing the machine	Basic	Introduction
Troubleshooting	Basic	Basic

## 2. MAINTENANCE AND REPAIR TRAINING

General operation of machines	Basic	Introduction
Symbols of drawings and codes	Basic	Not covered
Understanding hydraulic and electric schematics	Basic	Introduction
Control systems	Basic	Introduction
Function of main components (depending on equipment)	Basic	Introduction
Locations of components in the machine	Basic	Not covered
Periodical maintenance	Basic	Introduction
Troubleshooting	Basic	Not covered
Use of manuals	Basic	Introduction
Connection of hydraulic and electrical equipment	Basic	Not covered

## DIMENSIONS

	SE	LE		SE	LE
Length	10 910 mm	11 710 mm	Ground clearance	370 mm	370 mm
Width	2000 mm	2000 mm	Turning radius outer	7820 mm	8750 mm
Height	2360 mm	2360 mm	Turning radius (with boom turned 10°)	7200 mm	8080 mm
Wheel base	3650 mm	4450 mm	Turning radius inner	4480 mm	5610 mm
Track	1670 mm	1670 mm			

### SIDE VIEW – BASIC MACHINE

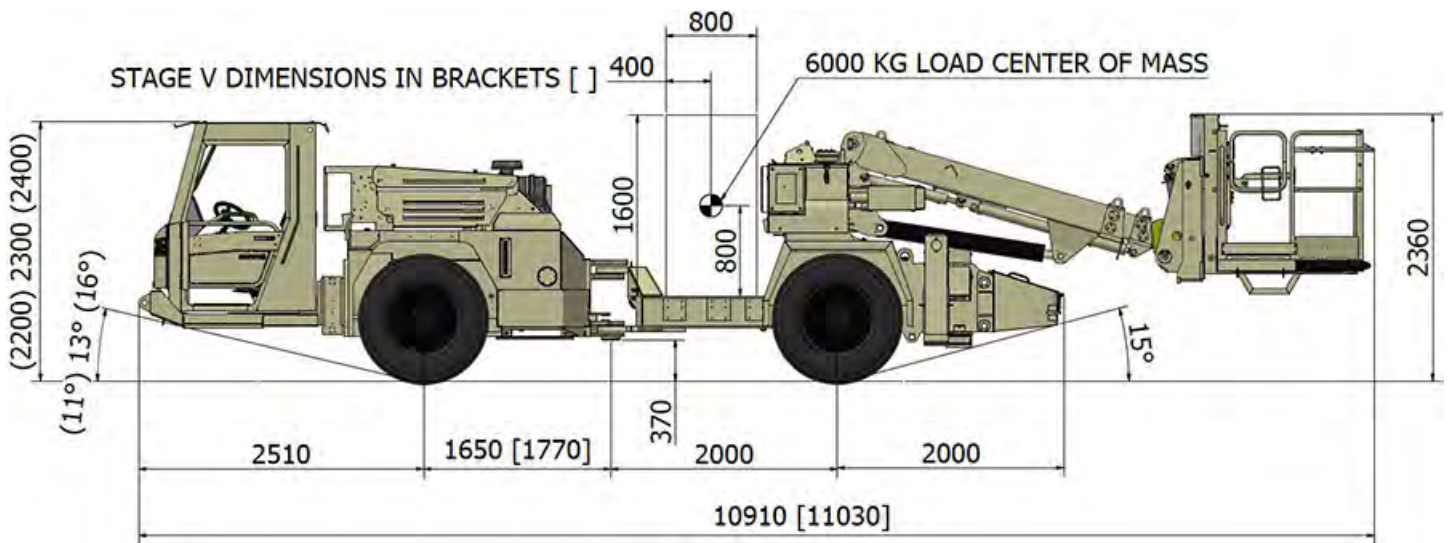

Charmec MF 605 D(V) SE

### SIDE VIEW – BASIC MACHINE

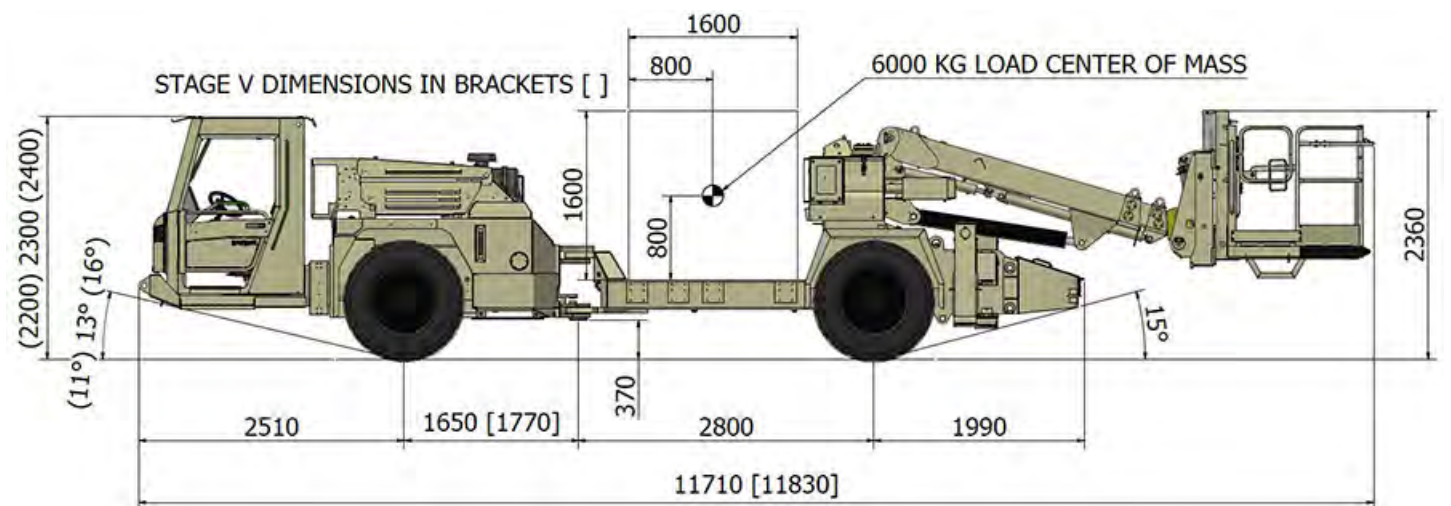

Charmec MF 605 D(V) LE

## SIDE VIEW – MACHINE WITH OPTIONS

STAGE V DIMENSIONS IN BRACKETS [ ]

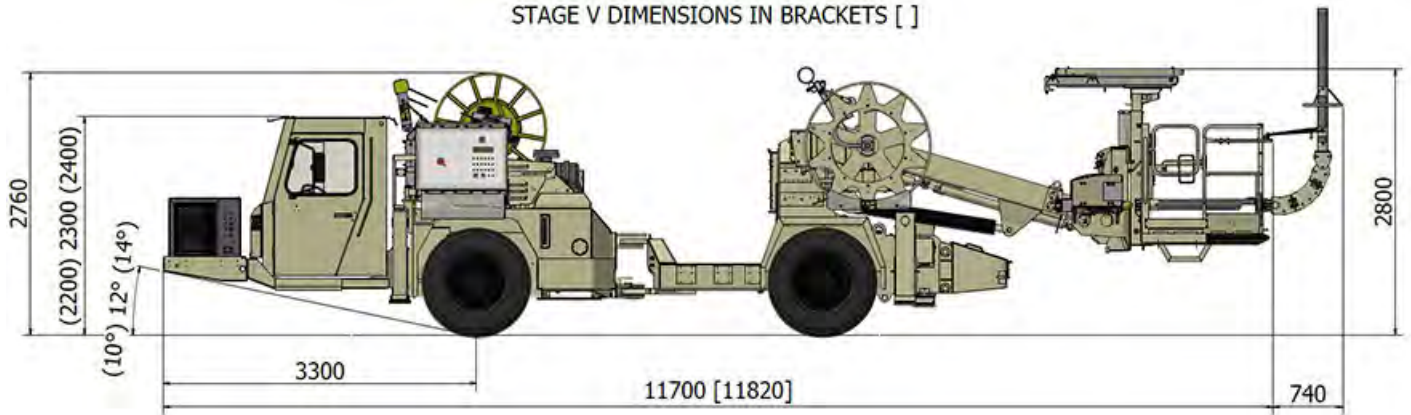

Charmec MF 605 D(V) SE

## SIDE VIEW – MACHINE WITH OPTIONS

STAGE V DIMENSIONS IN BRACKETS [ ]

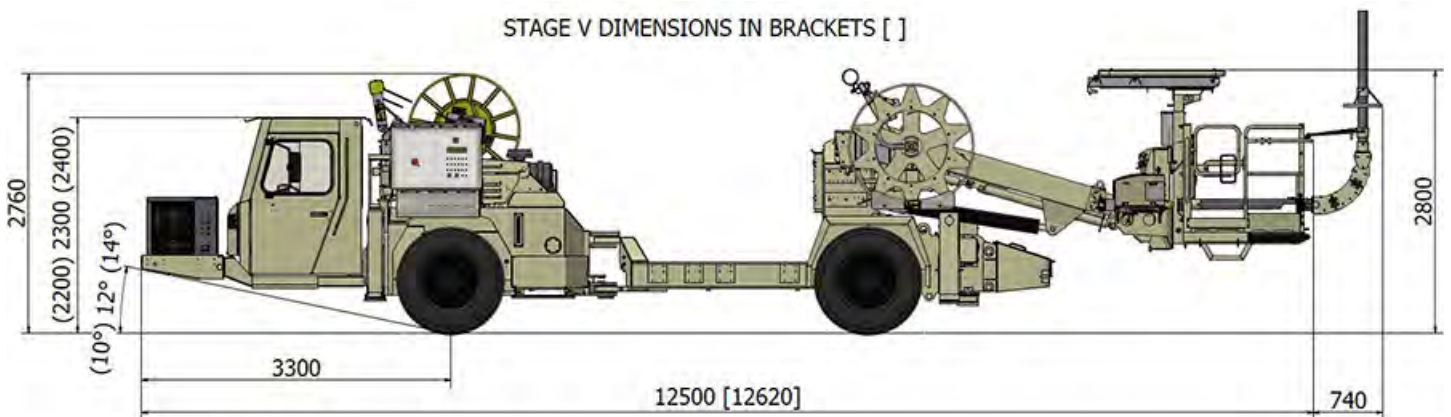

Charmec MF 605 D(V) LE

## TOP VIEW

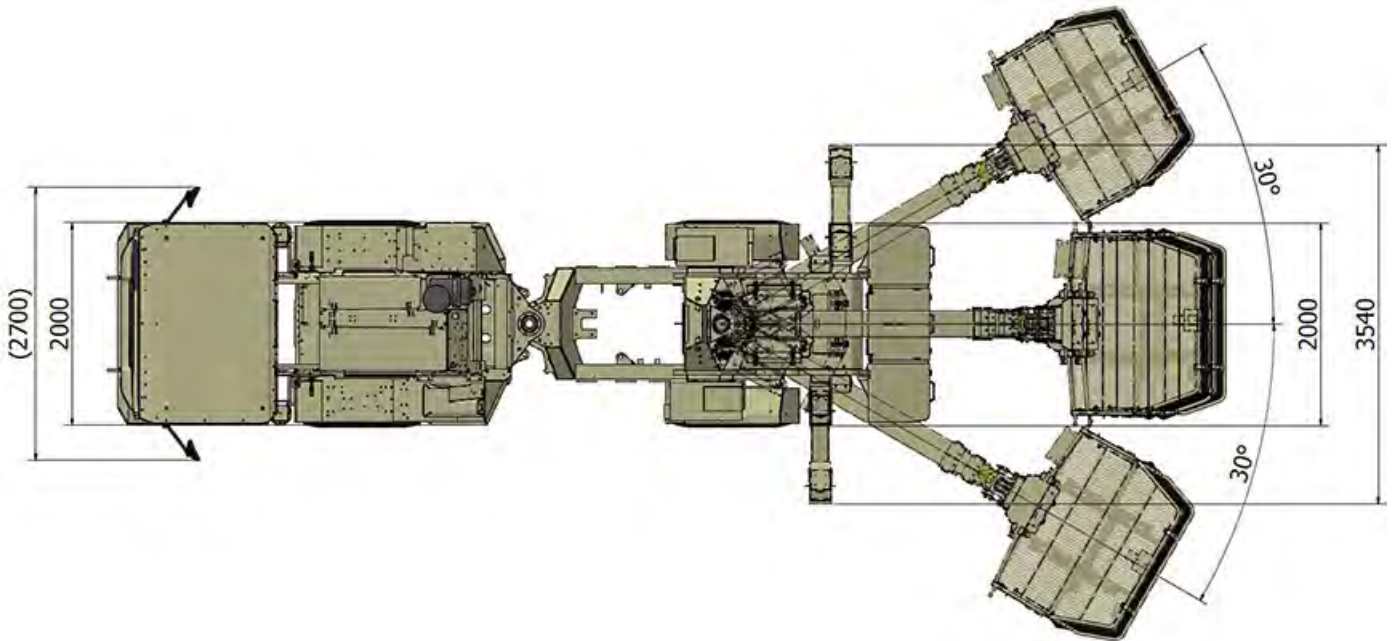

Charmec MF 605 SE

## TOP VIEW

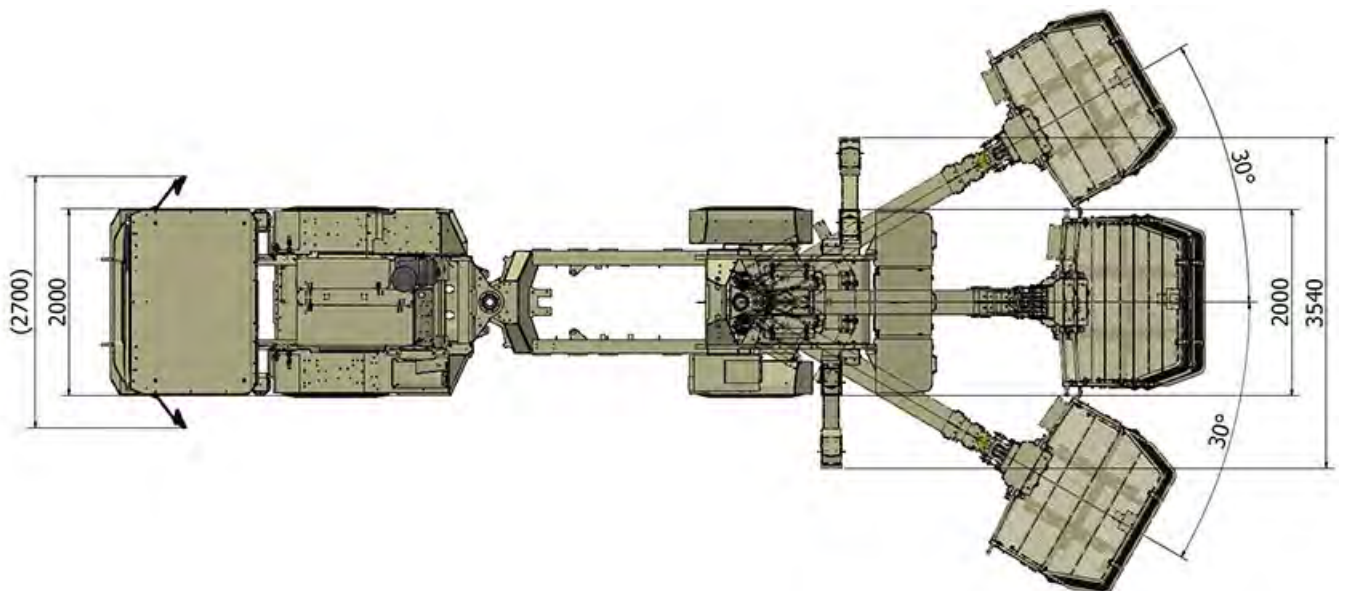

Charmec MF 605 LE

## TURNING RADIUS

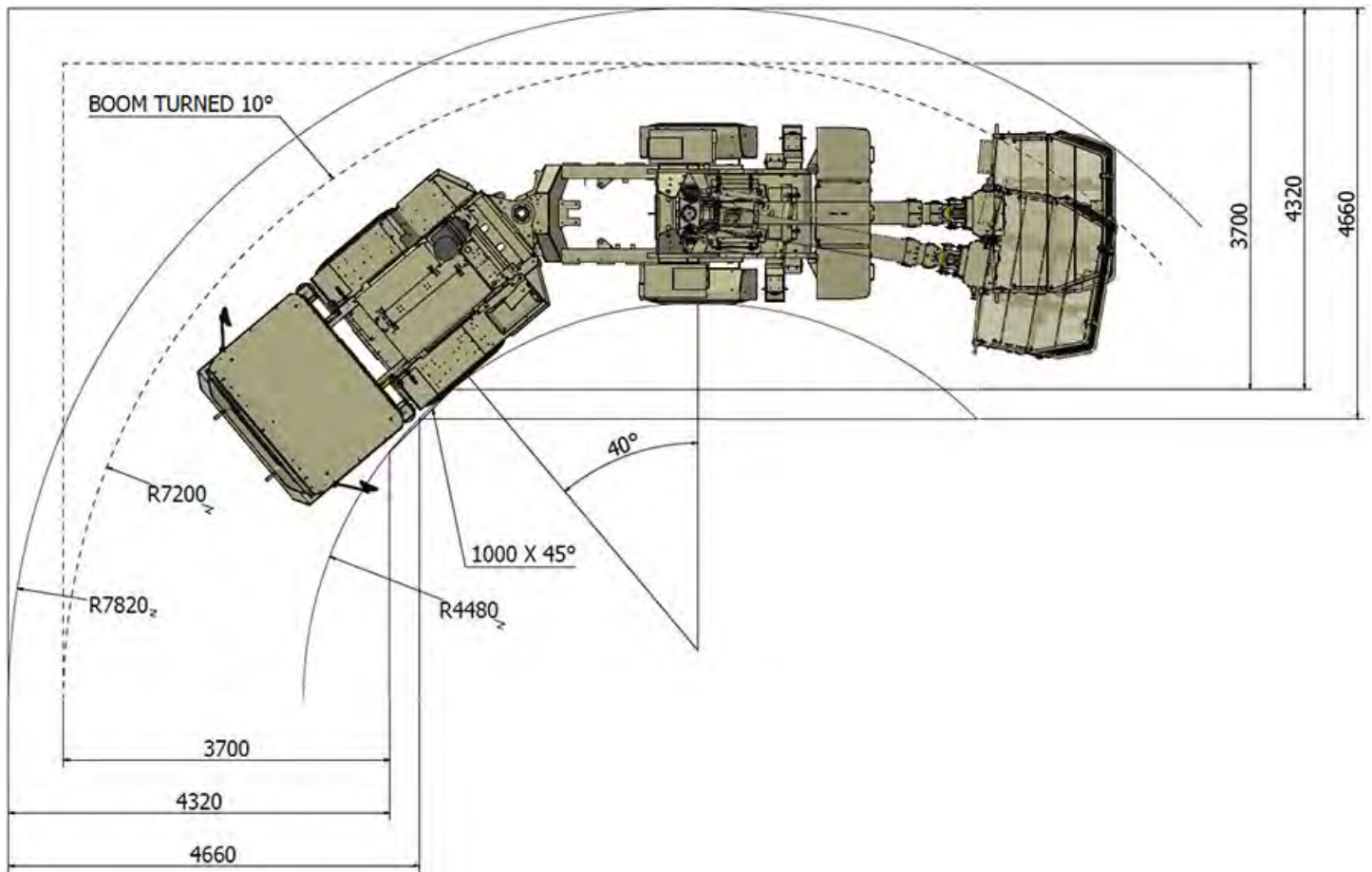

Charmec MF 605 D(V) SE

## TURNING RADIUS

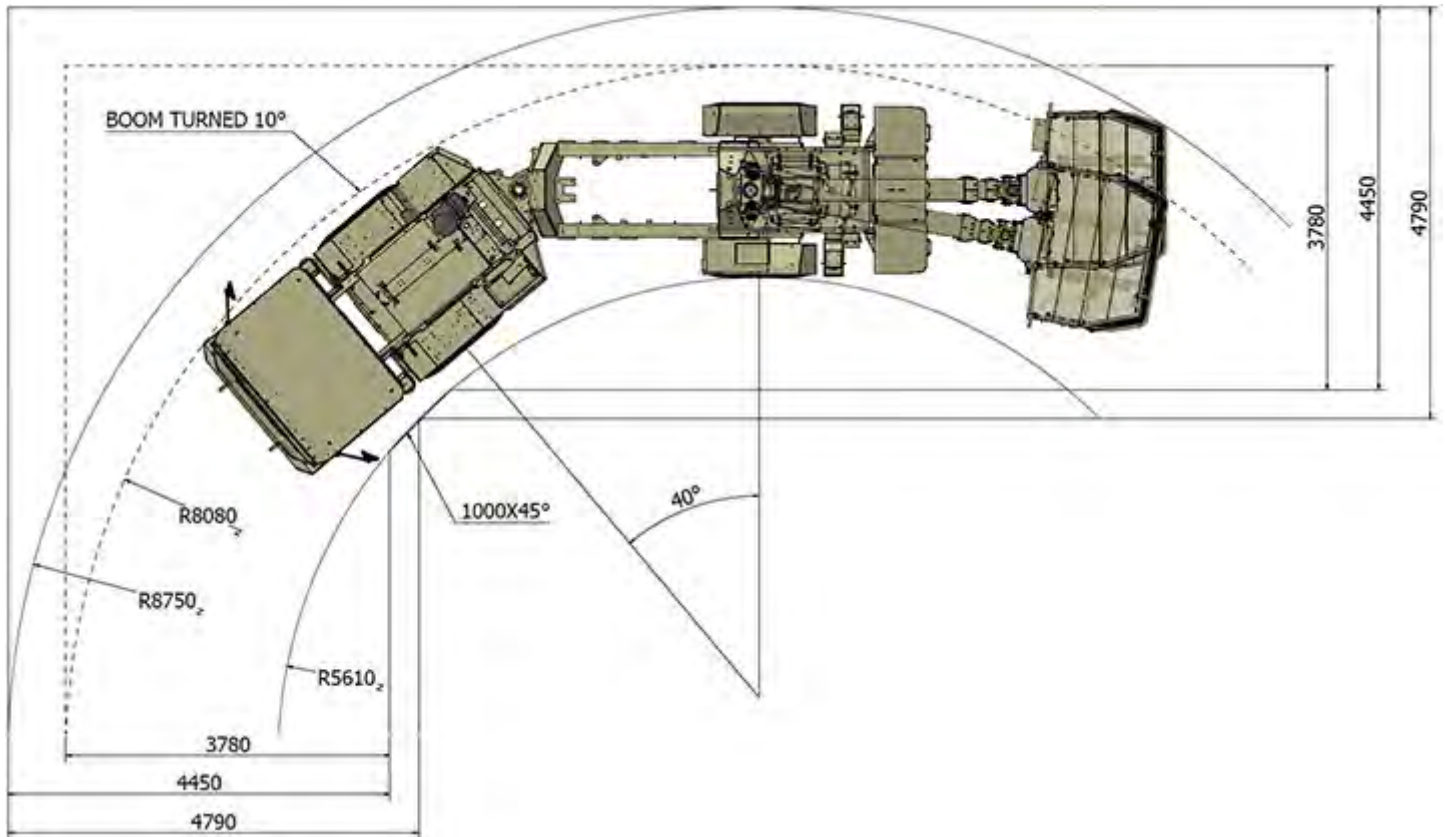

Charmec MF 605 D(V) LE

## FRONT VIEW

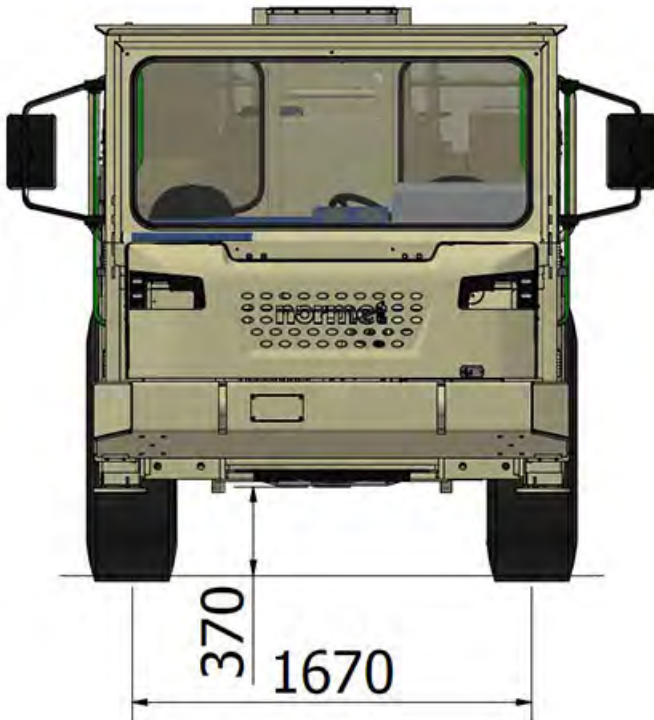



## BOOM REACH

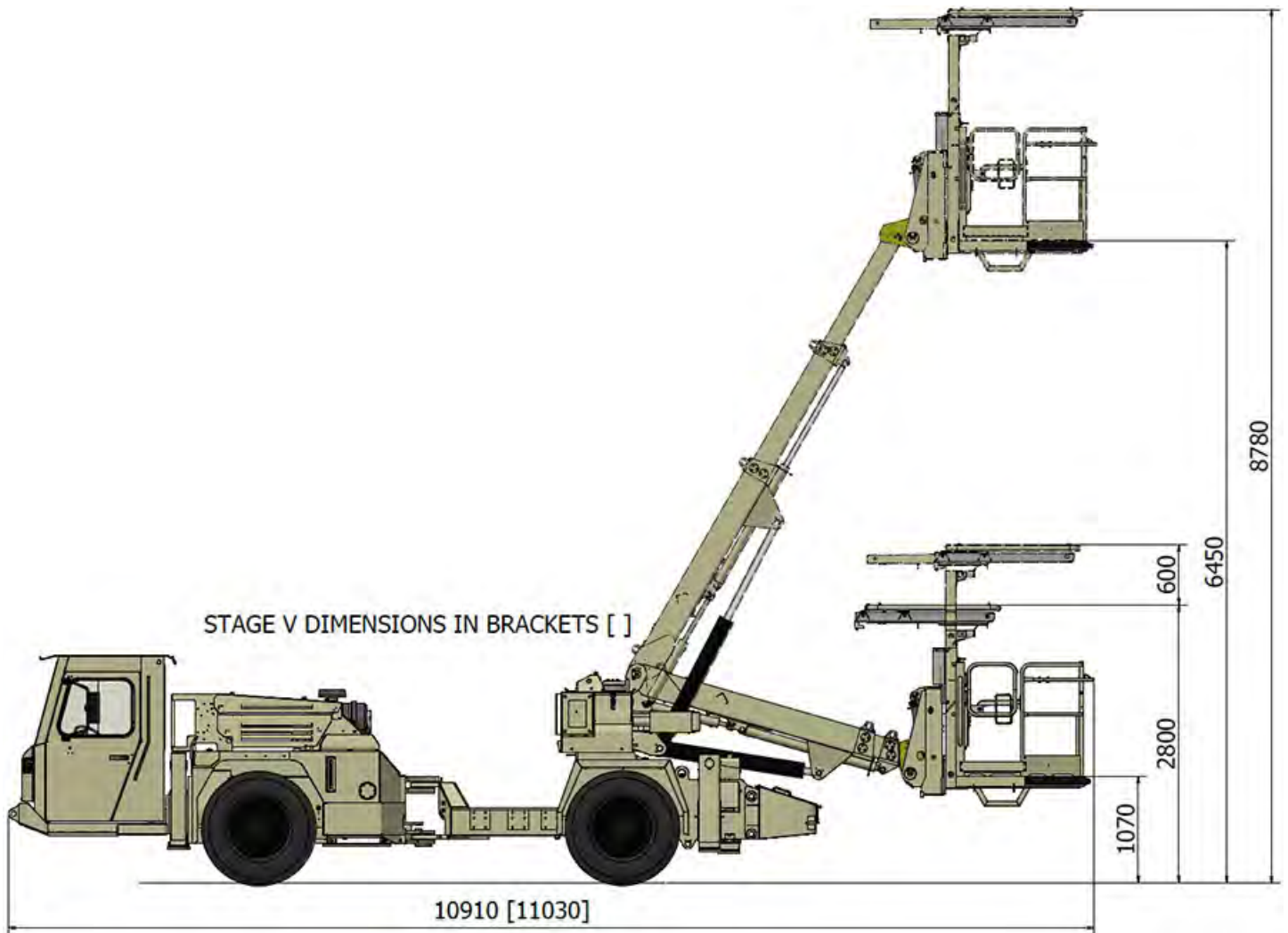

Charmec MF 605 D(V) SE

## BOOM REACH

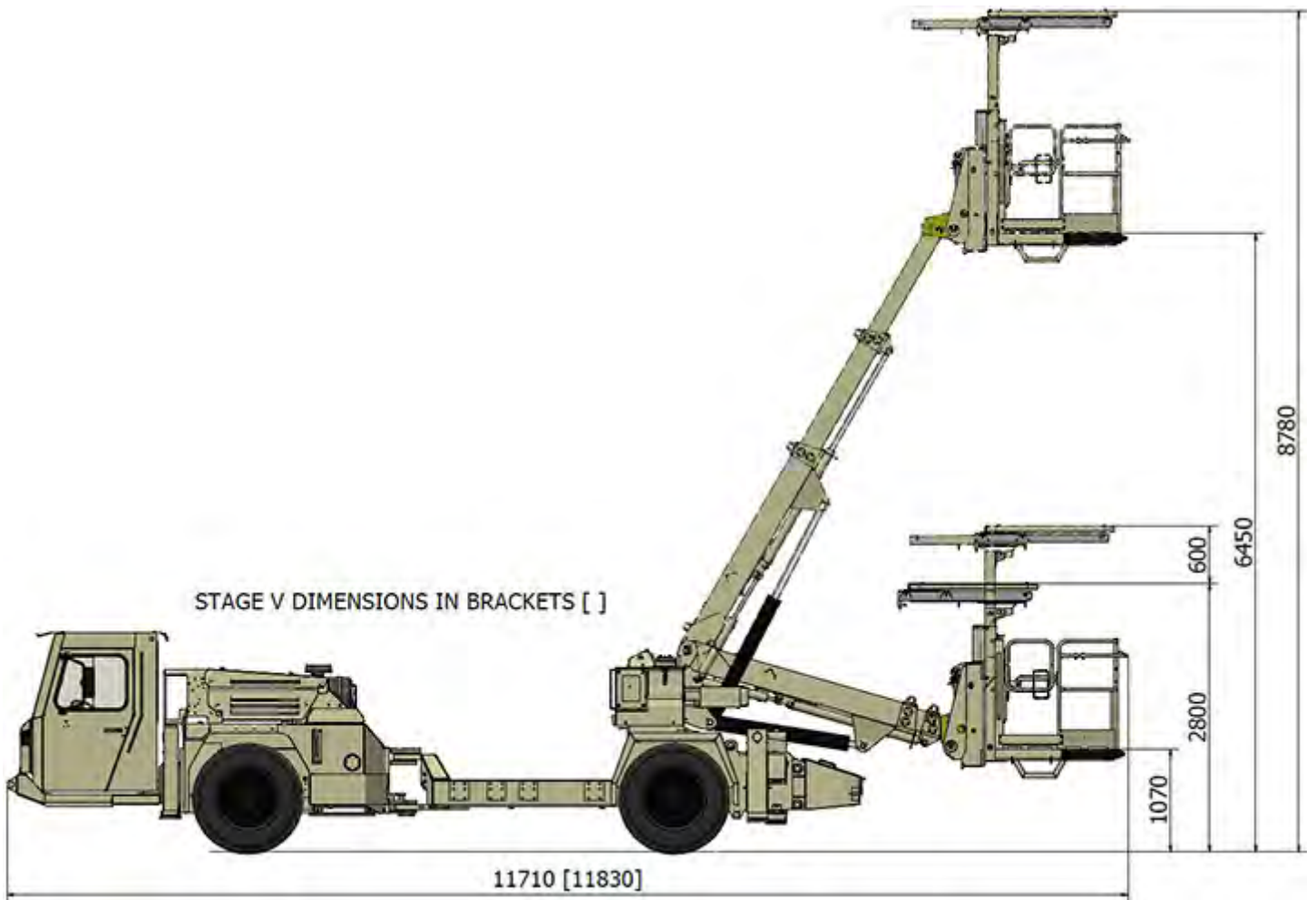

Charmec MF 605 D(V) LE

## BOOM REACH - NBB3S WITH 30° TURN

Maximized face coverage with single position of machine

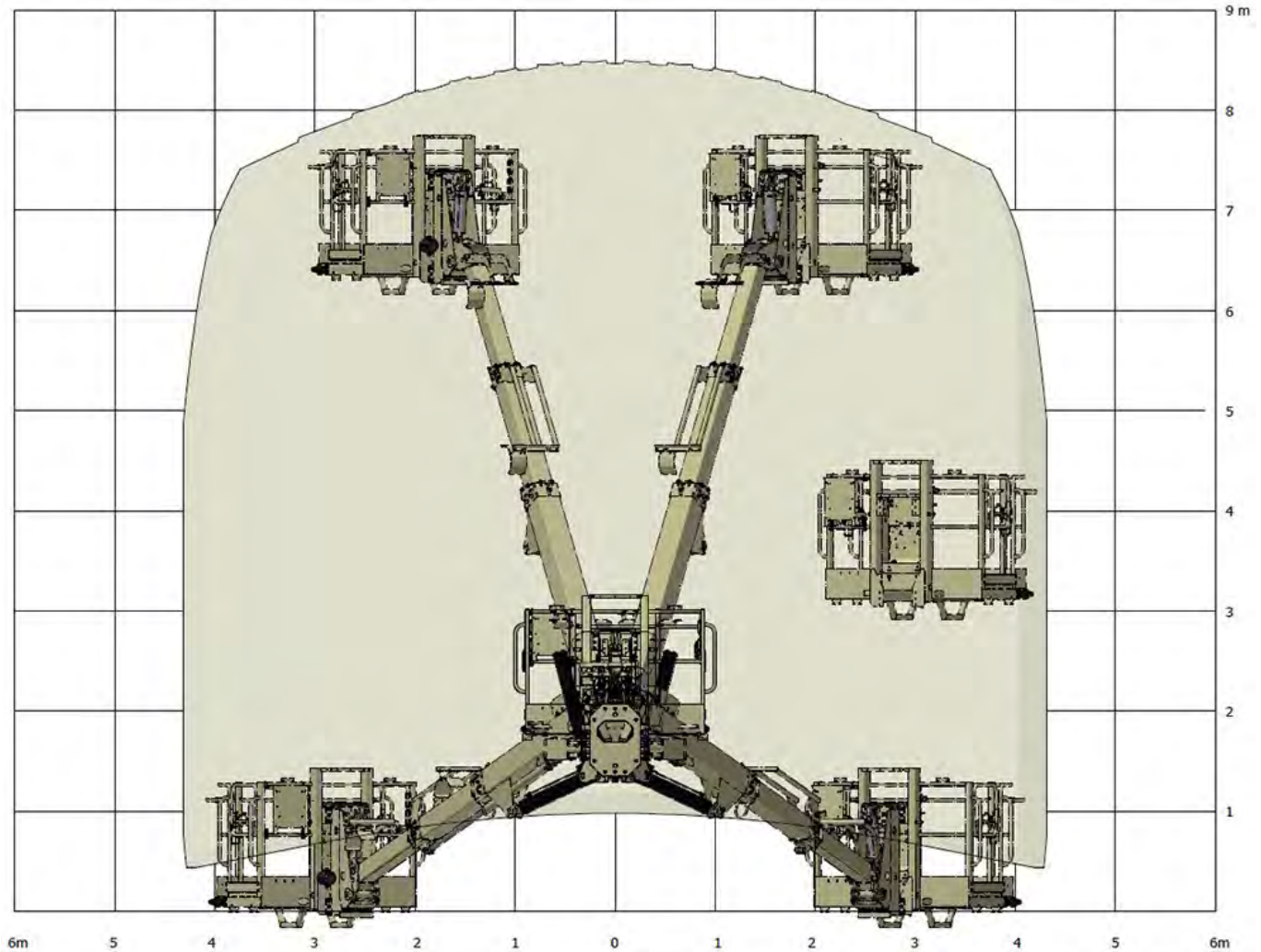

Normet reserves the right to change this specification without further notice

Pictures may include options and additional equipment.

## BOOM REACH - NBB3S WITH 30° TURN

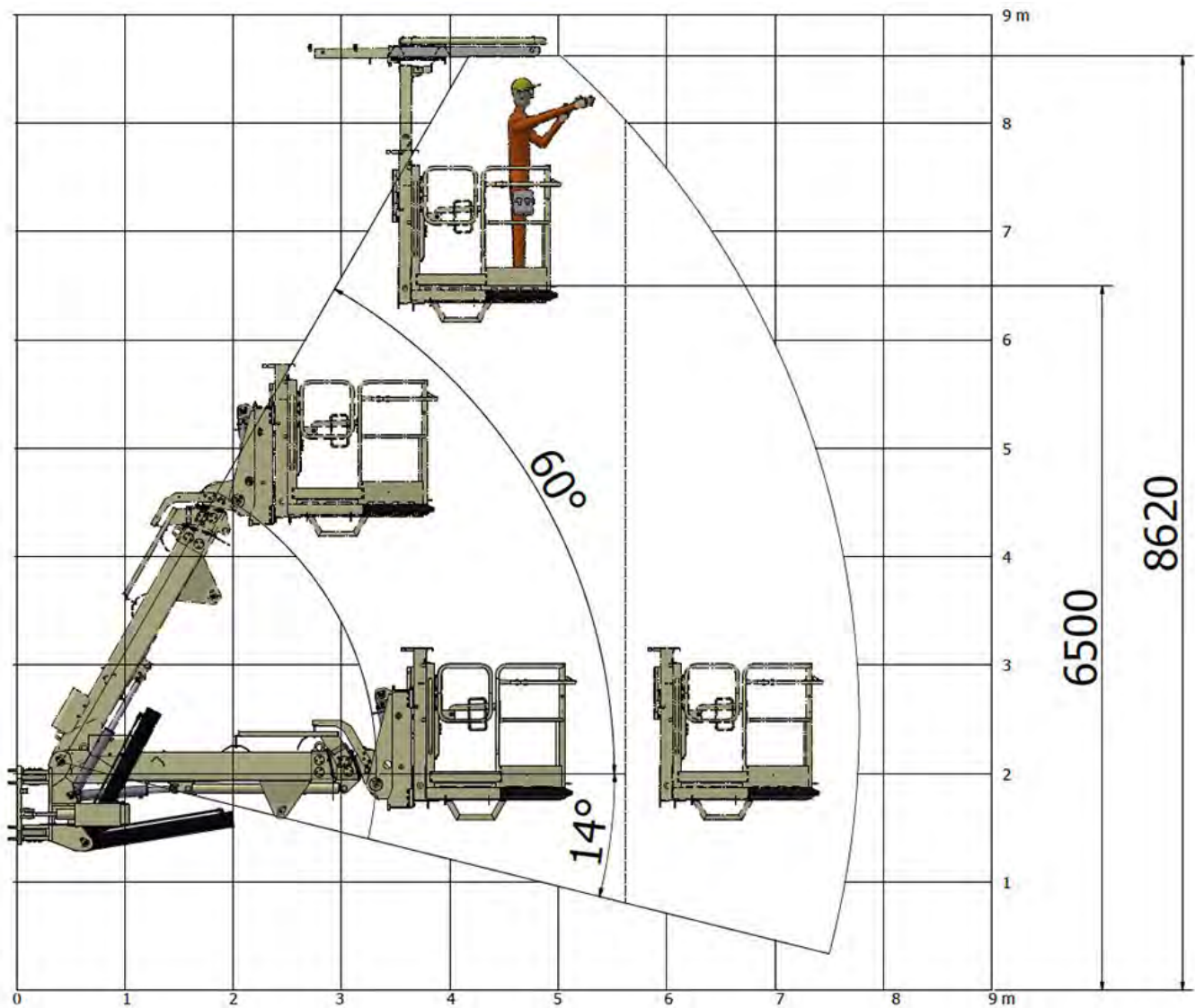

## TRACTIVE EFFORTS

### OPERATING WEIGHT

Empty	15 000 kg
Fully loaded	22 000 kg

### DEUTZ TCD 2013 L4, 120 KW

Performance curve DOC060005

#### Conversion chart

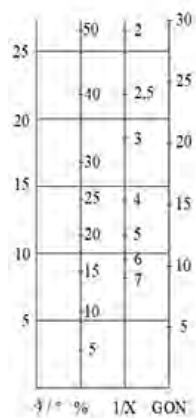

#### Gradeability kN

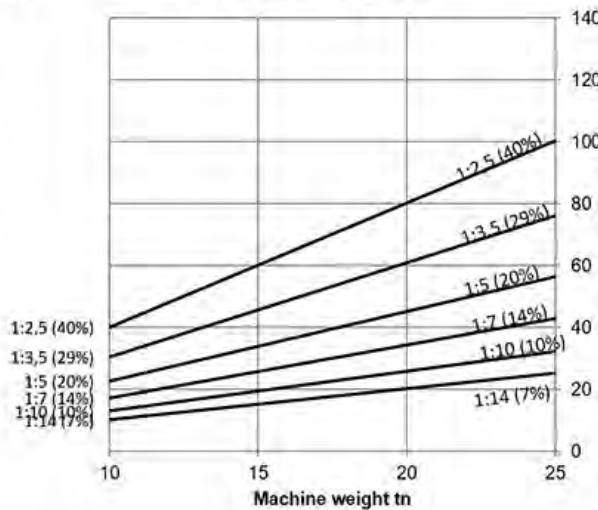

#### Tractive effort kN

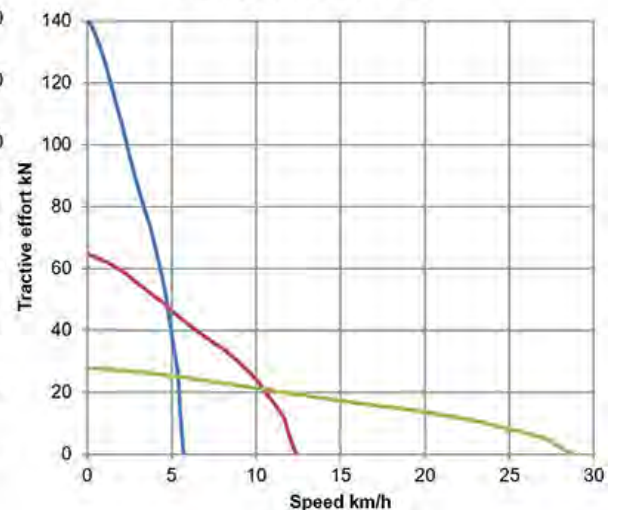

### MERCEDES-BENZ OM 904 LA 110 KW

Performance curve with lock-up 100006272

#### CONVERSION CHART

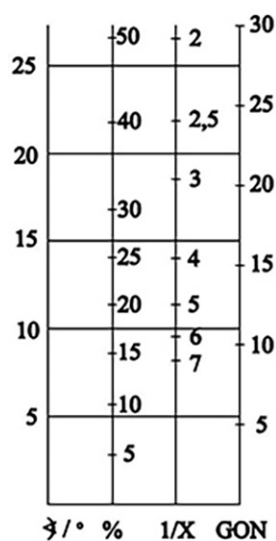

#### GRADIENT

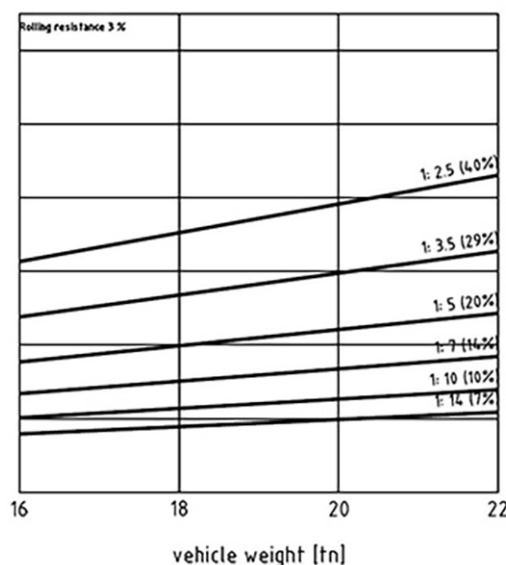

#### TRACTIVE EFFORT

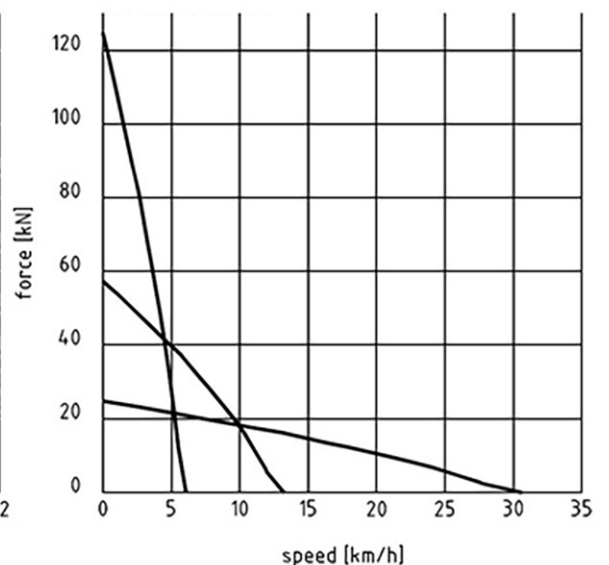

Normet reserves the right to change this specification without further notice

Pictures may include options and additional equipment.

## CUMMINS B 4.5 121 KW

Performance curve with lock-up DOC028557

### Conversion chart

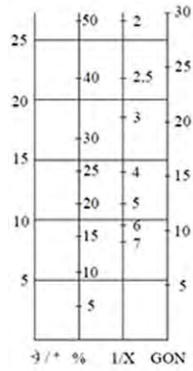

### Gradeability kN

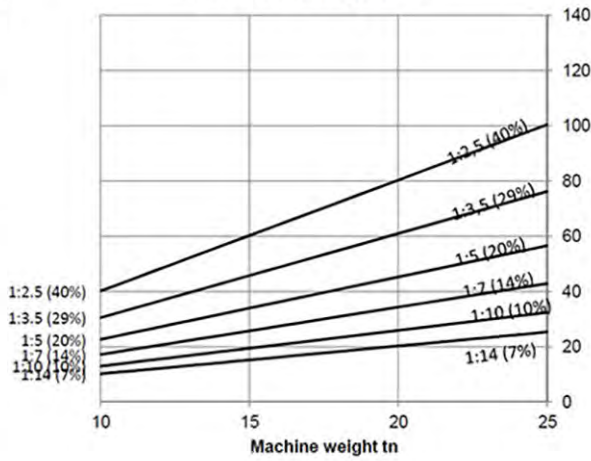

### Tractive effort kN

