



# Hydraulic Breakers L-Range



Normet reserves the right to change this specification without further notice

Pictures may include options and additional equipment.

## INTRODUCTION

**Normet Xrock Breakers** are made for professional use for excavators from 4 ton up to 100 ton. Breakers can be used on all common applications and tailored for special applications such as underwater jobs and extreme, hot applications. A diverse selection of breakers with small weight differences between 330 kg and 7200 kg ensure perfect match on every carrier.

### L-RANGE

L-range is the biggest range in Normet Xrock breaker offering, consisting of seven breakers designed for applications such as quarrying and mining, urban and infrastructure works, tunnelling and demolition. Their working weights vary from 1980 kg to 7200 kg, meant for excavators from 22 ton up to 100 ton. All L-range hammers have a wide selection of tools available. They are vibration and noise dampened, and they have membrane type accumulator, heavy duty hammer housing with extra Har-dox wear parts, durable polyurethane buffers, and advanced idle blow protection as a standard. Automatic greasing device can be selected as an option. Additionally, for special applications we offer optional hot and underwater kits.

**normet**  
**XROCK®**

# TECHNICAL SPECIFICATION

## HYDRAULIC BREAKERS

### XB27

Impact rate	360-550 bpm
Tool diameter	135 mm
Noise level	129 dB

### XB32

Impact rate	370-490 bpm
Tool diameter	145 mm
Noise level	135 dB

### XB36

Impact rate	390-540 bpm
Tool diameter	150 mm
Noise level	132 dB

### XB45

Impact rate	380-480 bpm
Tool diameter	160 mm
Noise level	130 dB

### XB56

Impact rate	370-450 bpm
Tool diameter	175 mm
Noise level	129 dB

### XB66

Impact rate	330-440 bpm
Tool diameter	190 mm
Noise level	130 dB

### XB102

Impact rate	250-350 bpm
Tool diameter	210 mm
Noise level	128 dB

Pressure hose

- Left side
- Right side

## HYDRAULIC SYSTEM

### XB27

Oil flow	120-180 l/min
Operating pressure	130-140 bar
Relief pressure	200 bar
Back pressure max.	10 bar

### XB32

Oil flow	160-210 l/min
Operating pressure	135-145 bar
Relief pressure	210 bar
Back pressure max.	10 bar

### XB36

Oil flow	190-240 l/min
Operating pressure	135-145 bar
Relief pressure	210 bar
Back pressure max.	10 bar

### XB45

Oil flow	210-260 l/min
Operating pressure	135-145 bar
Relief pressure	210 bar
Back pressure max.	10 bar

### XB56

Oil flow	220-270 l/min
Operating pressure	140-150 bar
Relief pressure	210 bar
Back pressure max.	10 bar

### XB66

Oil flow	230-300 l/min
Operating pressure	145-155 bar
Relief pressure	210 bar
Back pressure max.	10 bar

### XB102

Oil flow	250-350 l/min
Operating pressure	150-160 bar
Relief pressure	220 bar
Back pressure max.	10 bar

## HOSES

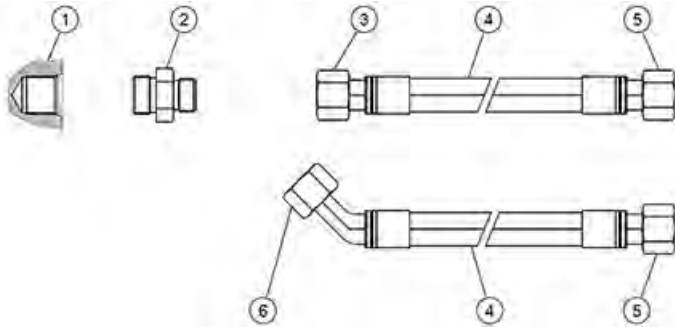

- 1 Breaker port
- 2 Breaker port to hose head (nipple size)
- 3 Head of hose (breaker side)
- 4 Hose
- 5 Head of hose (excavator side)
- 6 Head of hose (breaker side)

IN HOSES						
	XB27 & 32	XB36	XB45	XB56	XB66	XB102
1	1"	1"	1"	1-1/4"	1-1/4"	1-1/2"
2	1" - 42x2"	1" - 42x2"	1" - 42x2"	1-1/4" - 42x2"	1-1/4" - 42x2"	1-1/2" - 1-1/2"
3	42x2"	42x2" (45°) (6)	42x2"	42x2"	42x2"	1-1/2"
4	1"	1"	1"	1"	1"	1-1/2"
5	*	*	*	*	*	*

OUT HOSES						
	XB27 & 32	XB36	XB45	XB56	XB66	XB102
1	1-1/4"	1-1/4"	1-1/4"	1-1/4"	1-1/4"	2"
2	1-1/4" - 42x2"	1-1/4" - 42x2"	1-1/4" - 42x2"	1-1/4" - 42x2"	1-1/4" - 42x2"	2"-2"
3	42x2"	42x2" (45°) (6)	42x2"	42x2"	42x2"	2"
4	1" (for 27) & 1-1/4" (for 32)	1-1/4"	1-1/4"	1-1/4"	1-1/4"	2"
5	*	*	*	*	*	*

\*) The measurement depends on the excavator model

## TECHNICAL DOCUMENTATION

Standard documents:

Instruction manuals, hard copy 1 pcs:

- English
- Russian
- One of destination EU languages

Spare parts manuals, hard copy 1 pcs:

- English

PDF manuals on USB-stick 1 pcs, includes instruction and spare parts manuals

Additional documentation:

- Extra hard copies of manuals
- Extra PDF manuals
- LinkOne WebView electronic manuals
- Other than standard language manuals
- Dimensional (G.A.) drawings

# ACCESSORIES

## MAIN ACCESSORIES

- Underwater use kit
- Hot application kit

## PROCESS PRODUCTIVITY

- Tools
  - Blunt
  - Moil point
  - Chisel
- Automatic lubrication system

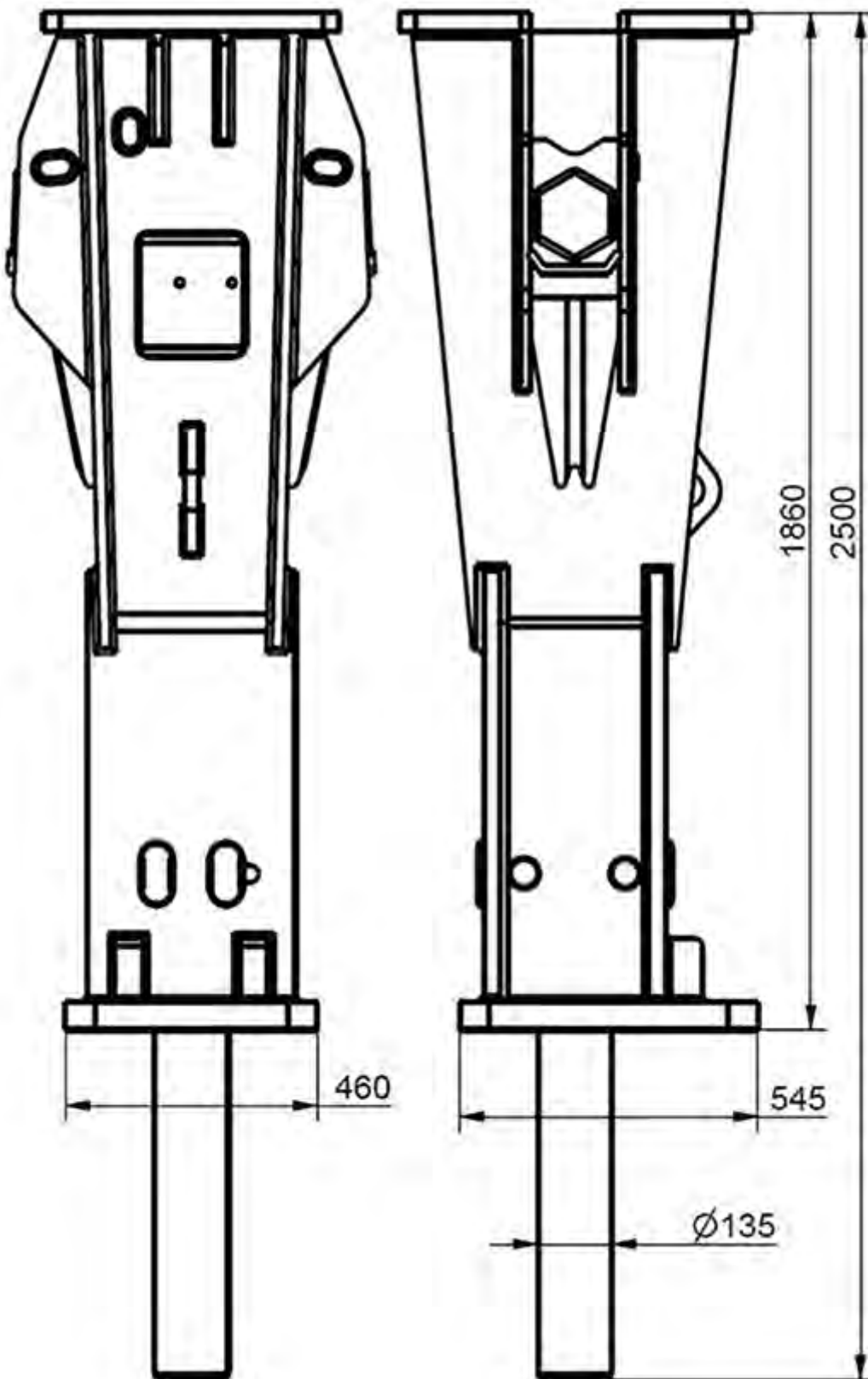
**DIMENSIONS****SIDE VIEW XB27**

Normet reserves the right to change this specification without further notice

Pictures may include options and additional equipment.

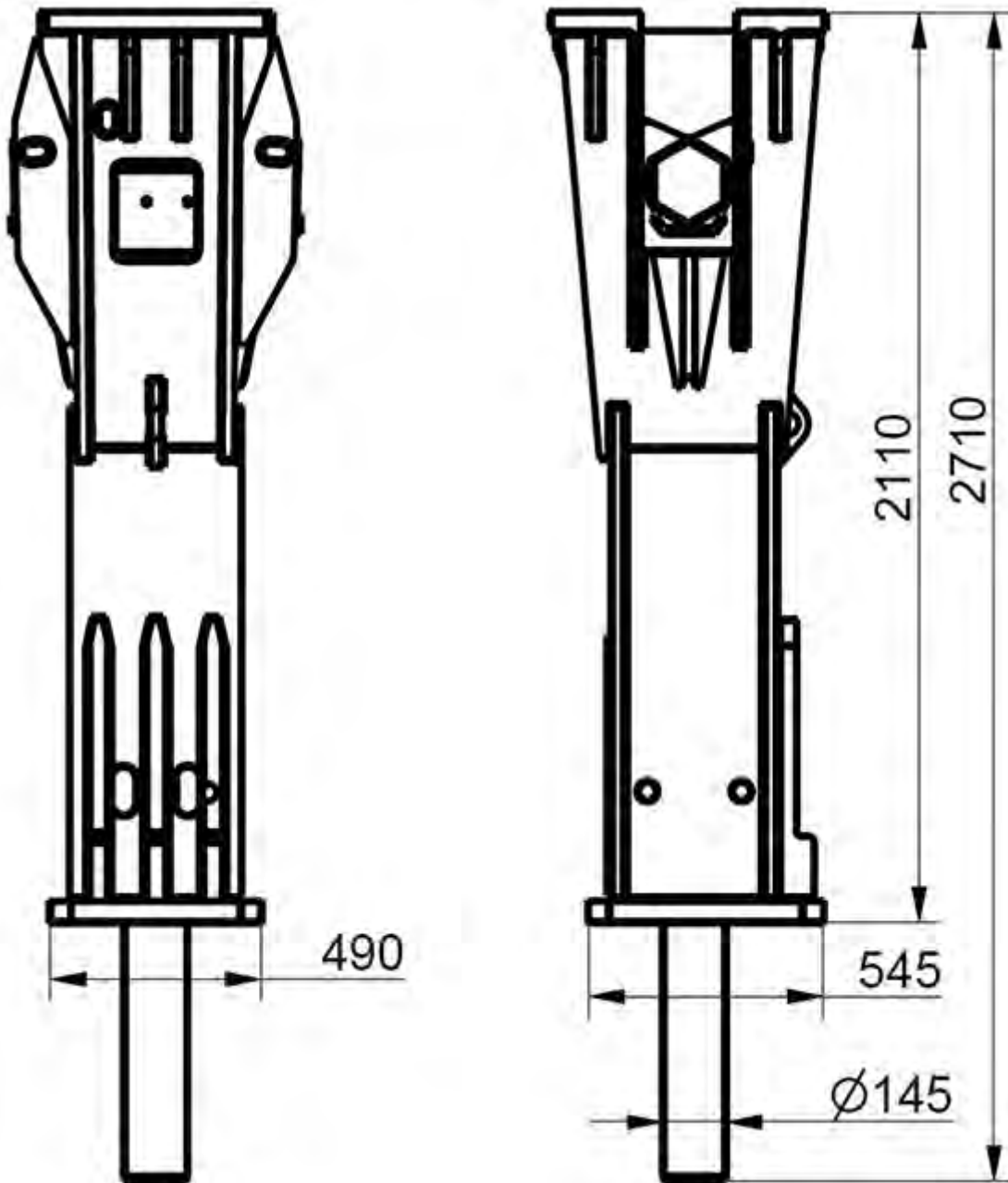

**SIDE VIEW XB32**

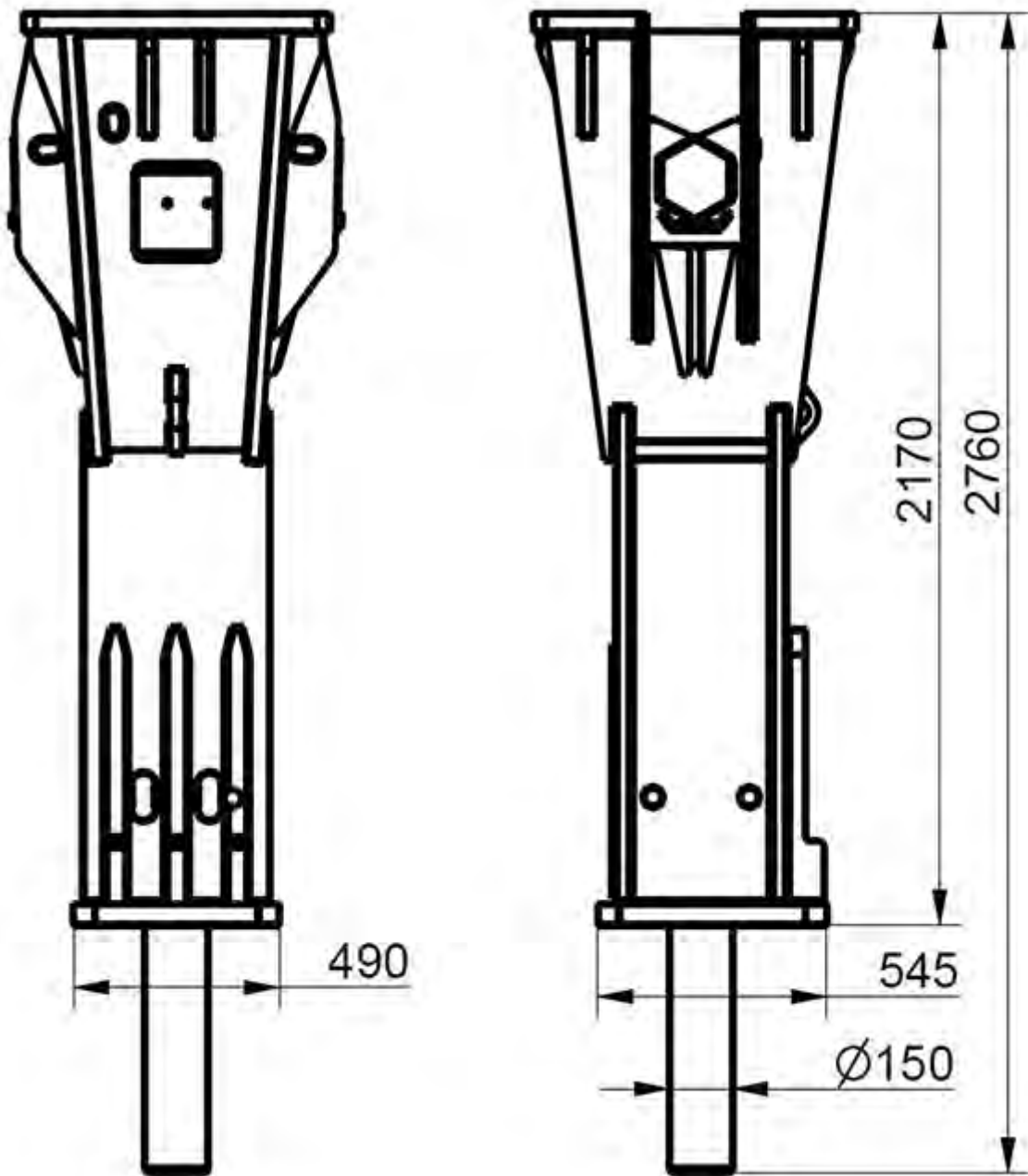
**SIDE VIEW XB36**

Normet reserves the right to change this specification without further notice

Pictures may include options and additional equipment.

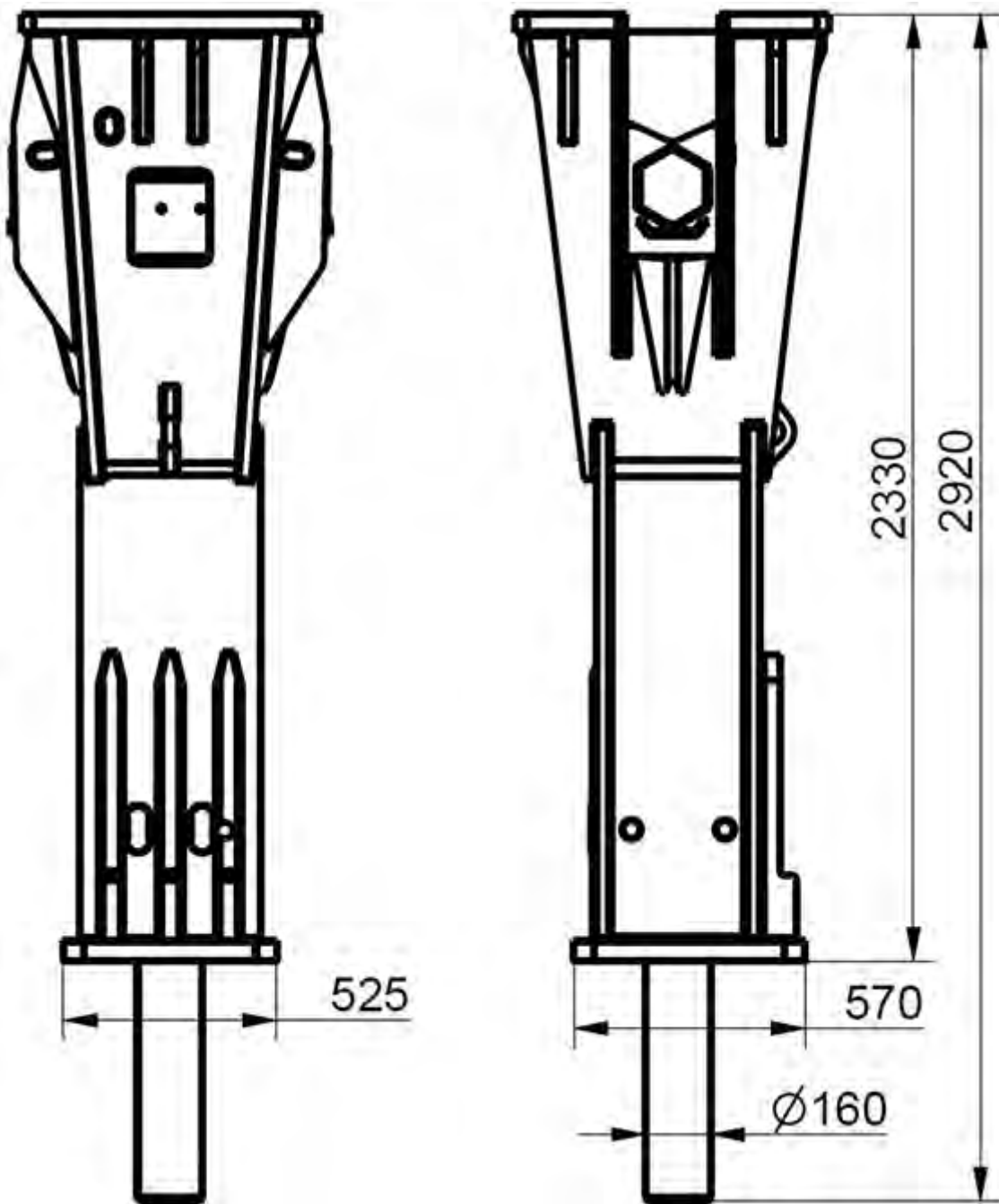

**SIDE VIEW XB45**

## SIDE VIEW XB56

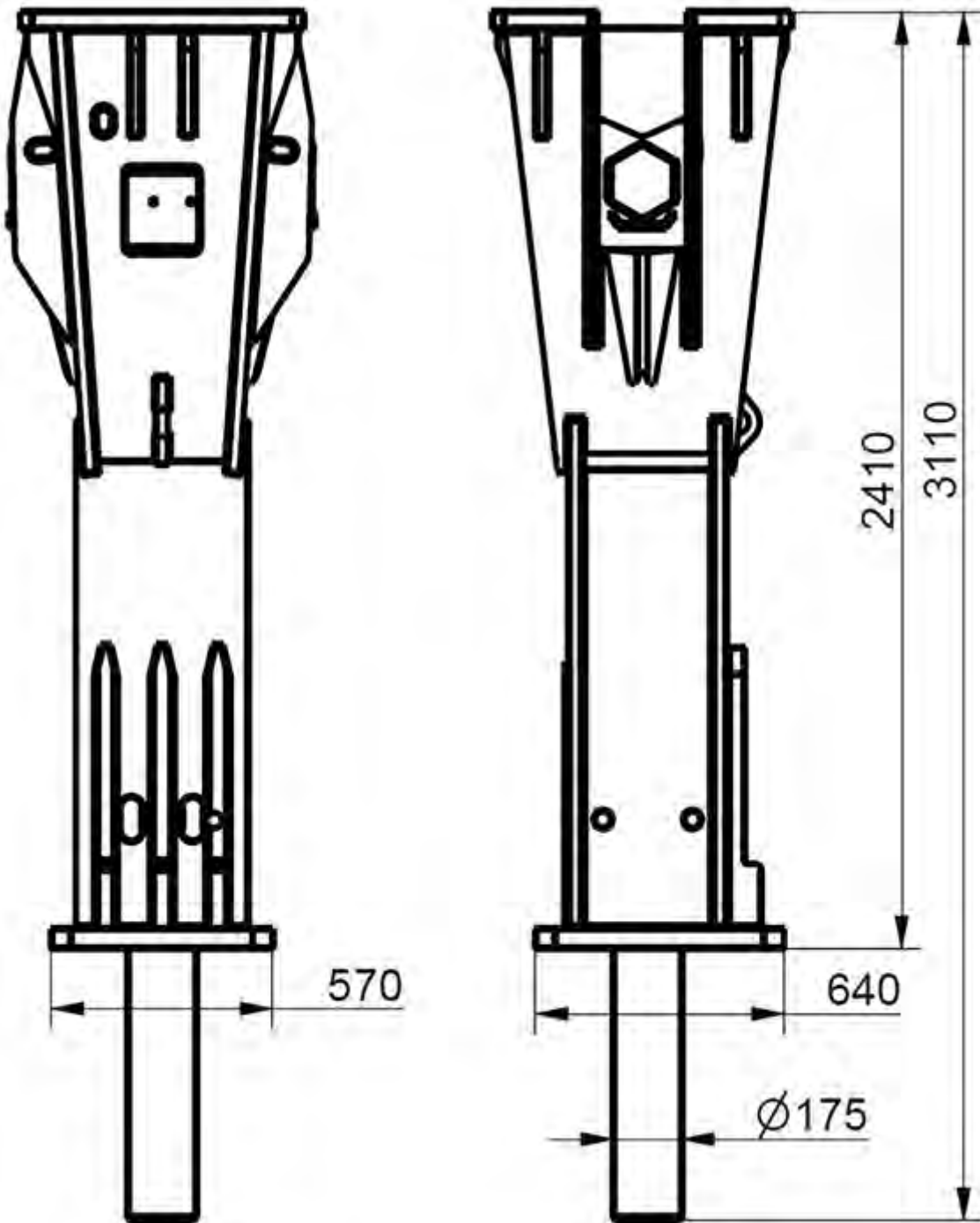

Normet reserves the right to change this specification without further notice

Pictures may include options and additional equipment.

## SIDE VIEW XB66

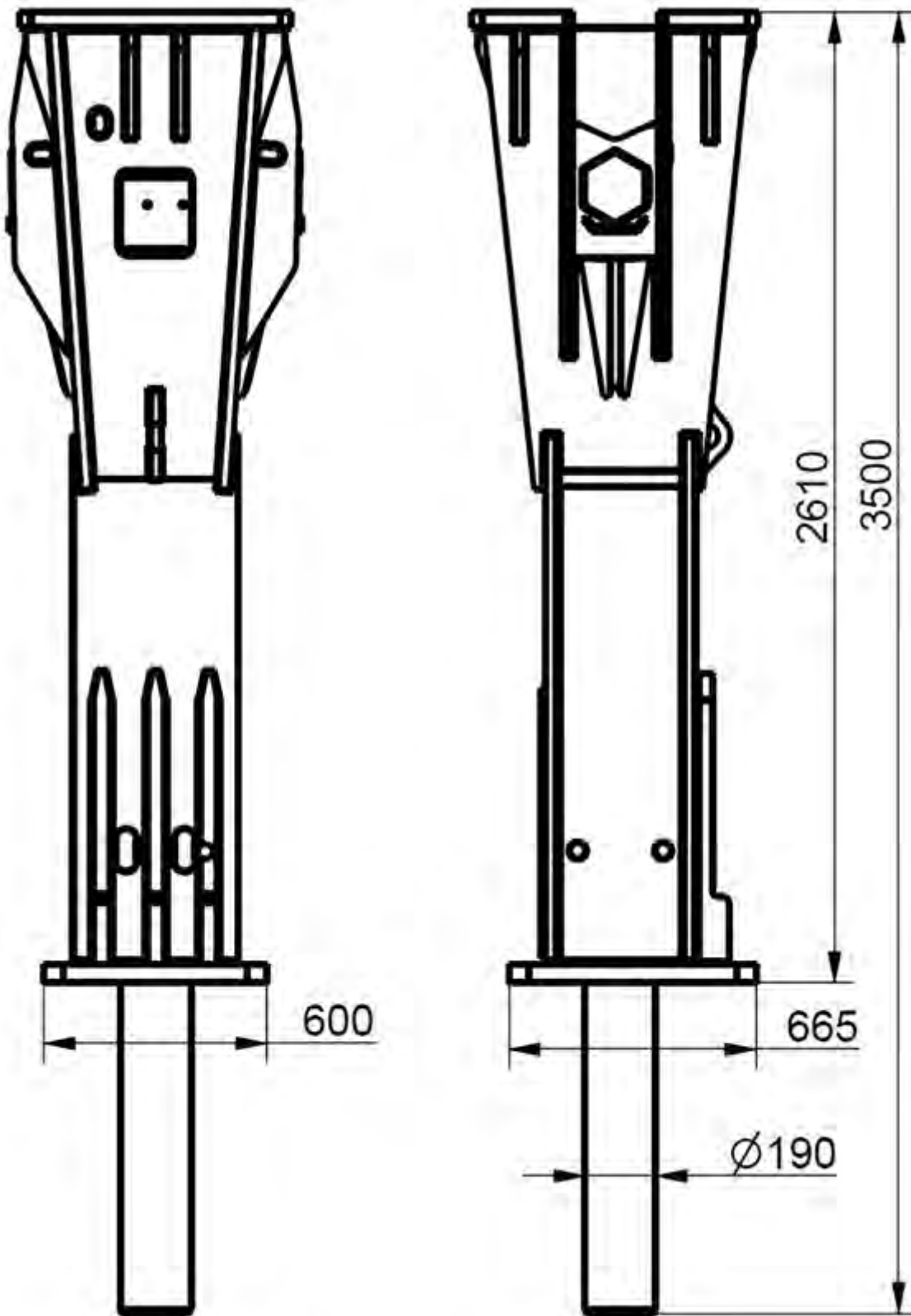

Normet reserves the right to change this specification without further notice

Pictures may include options and additional equipment.

## SIDE VIEW XB102

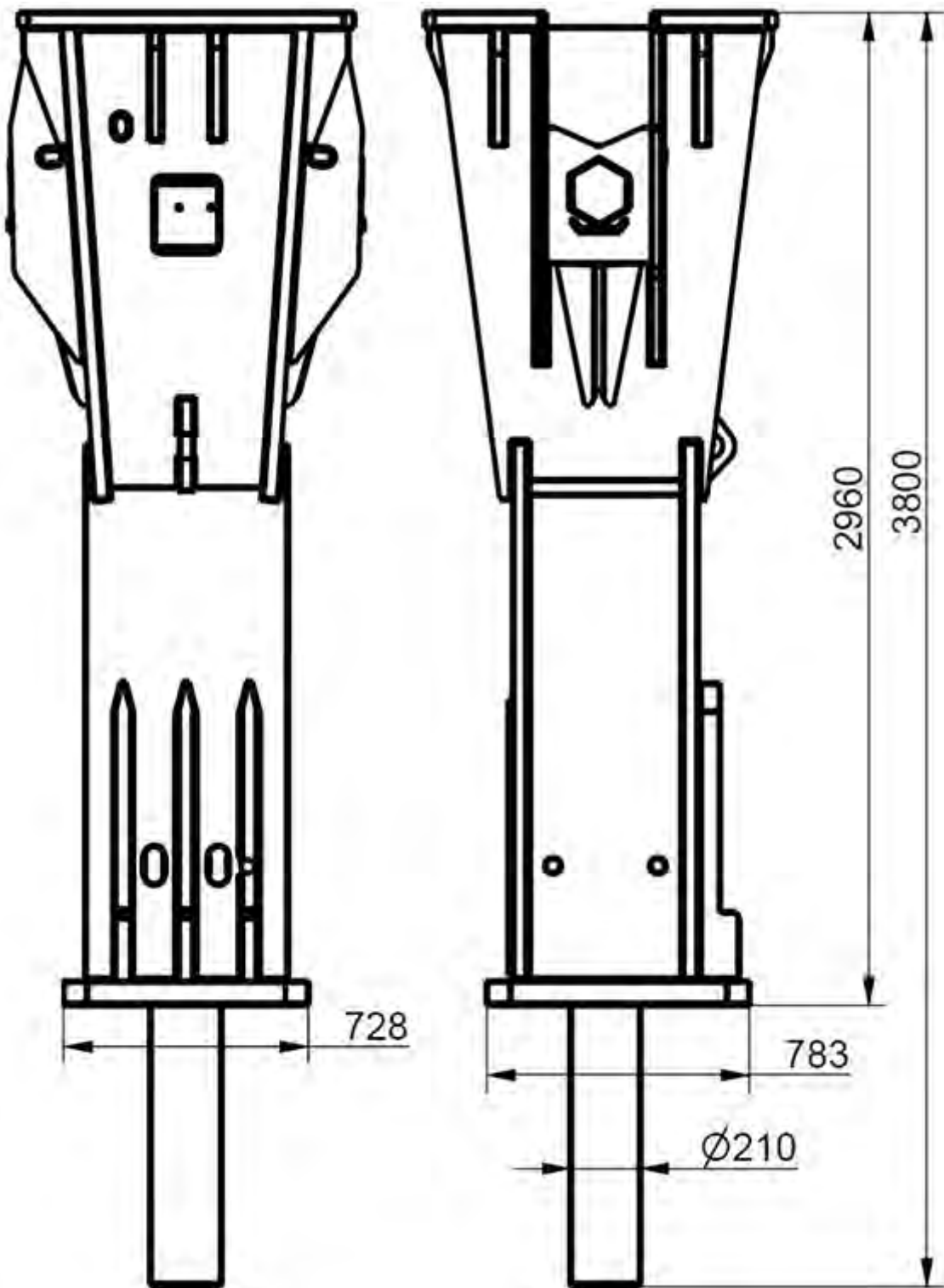

Normet reserves the right to change this specification without further notice

Pictures may include options and additional equipment.

## TOP VIEW XB27

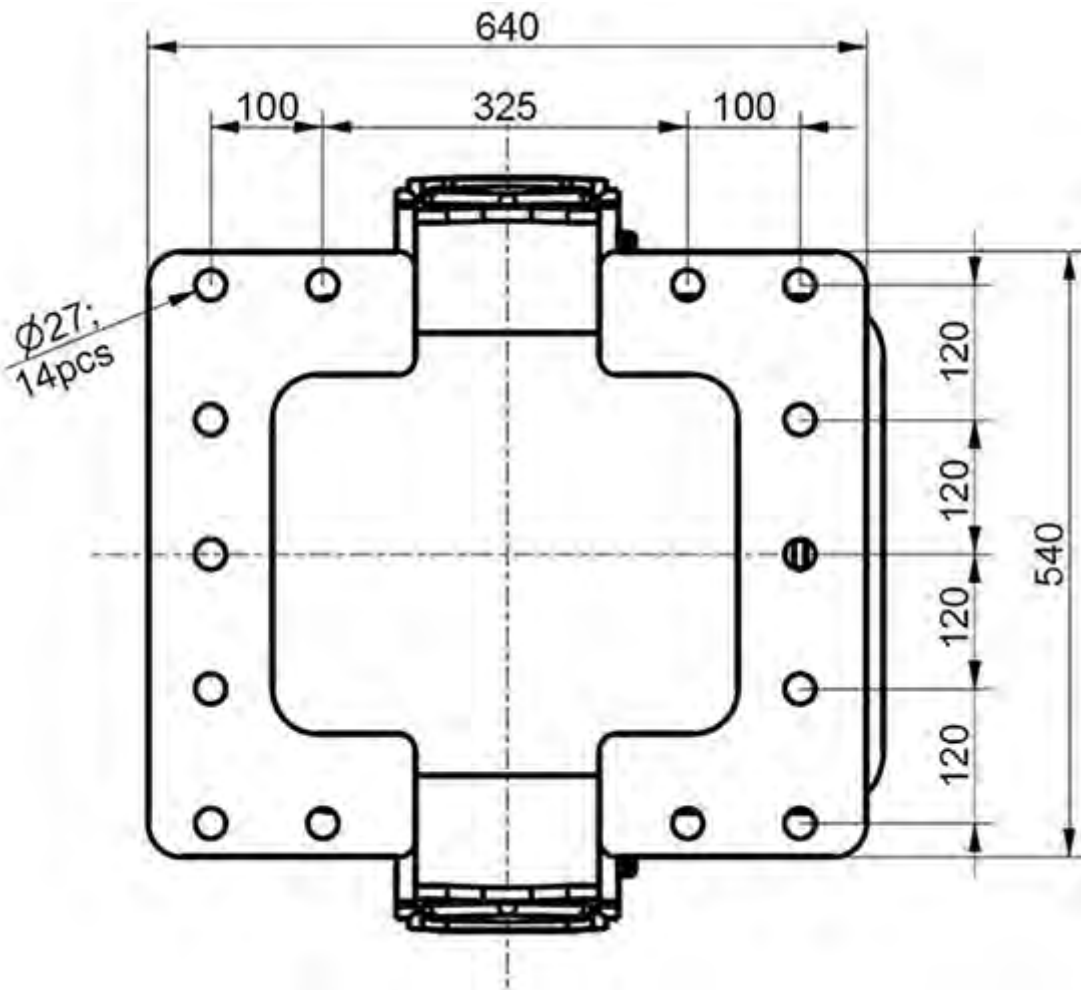

## TOP VIEW XB32

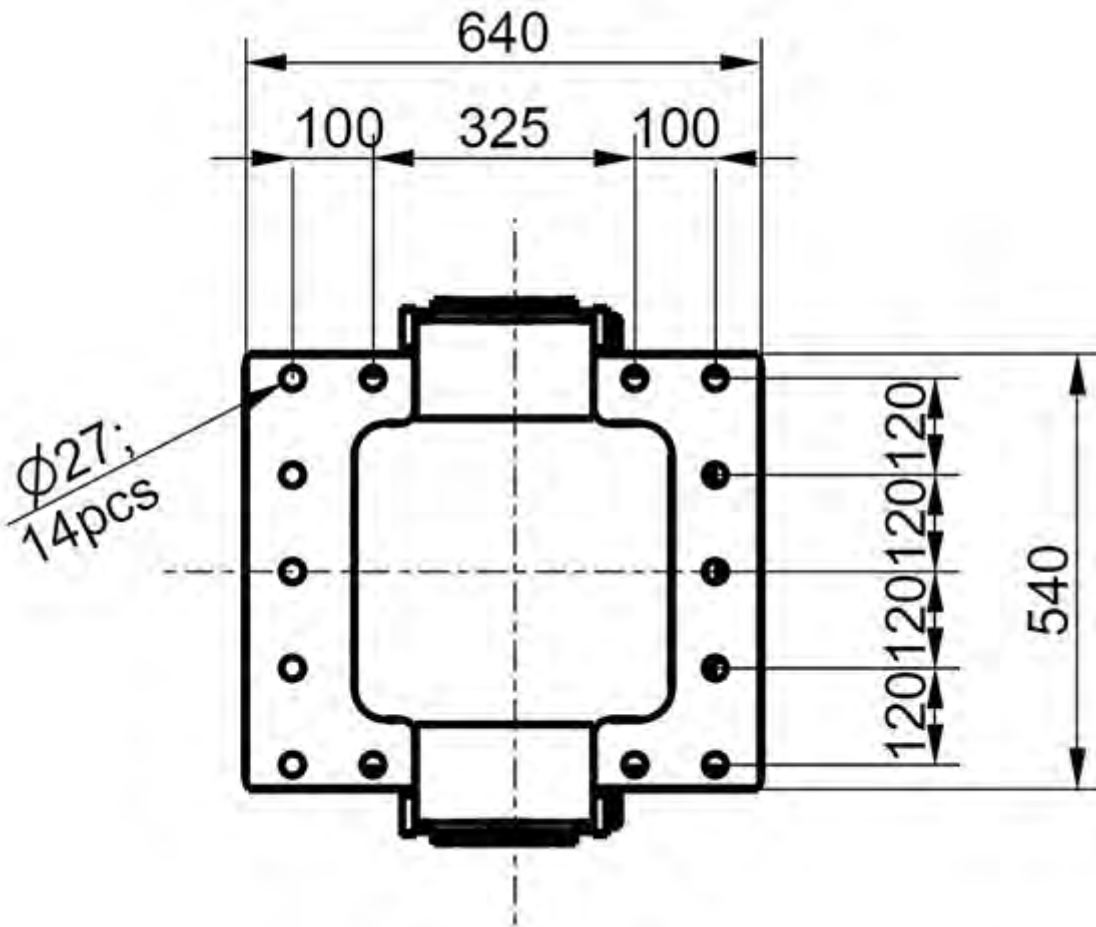

## TOP VIEW XB36

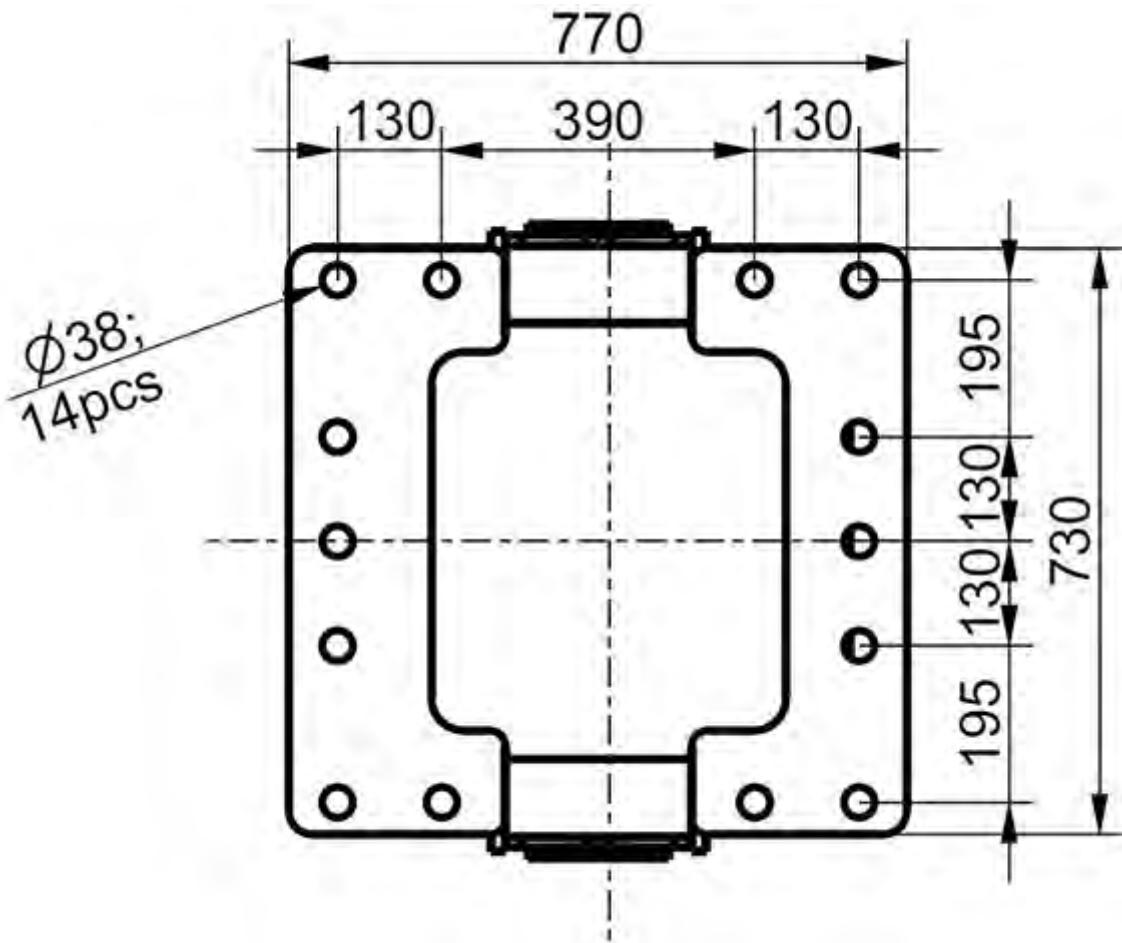



## TOP VIEW XB45

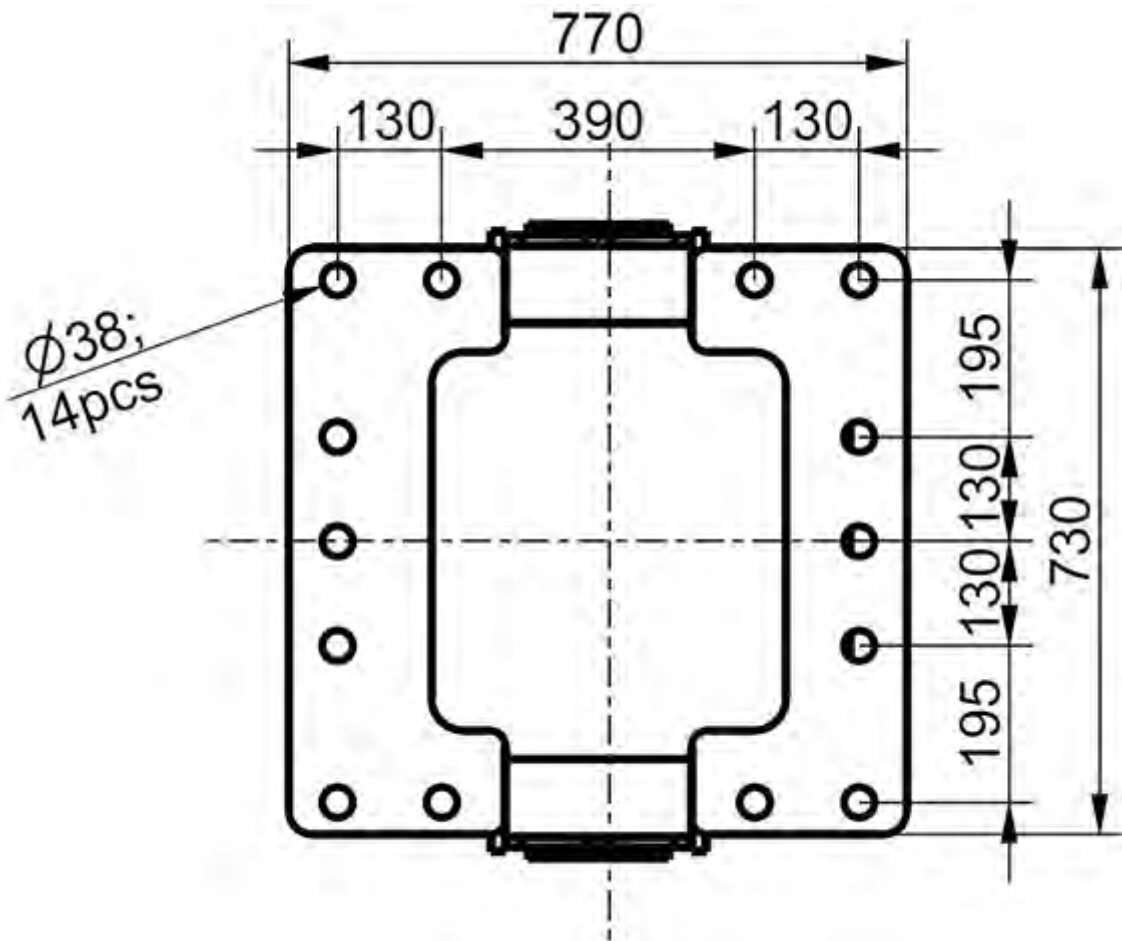

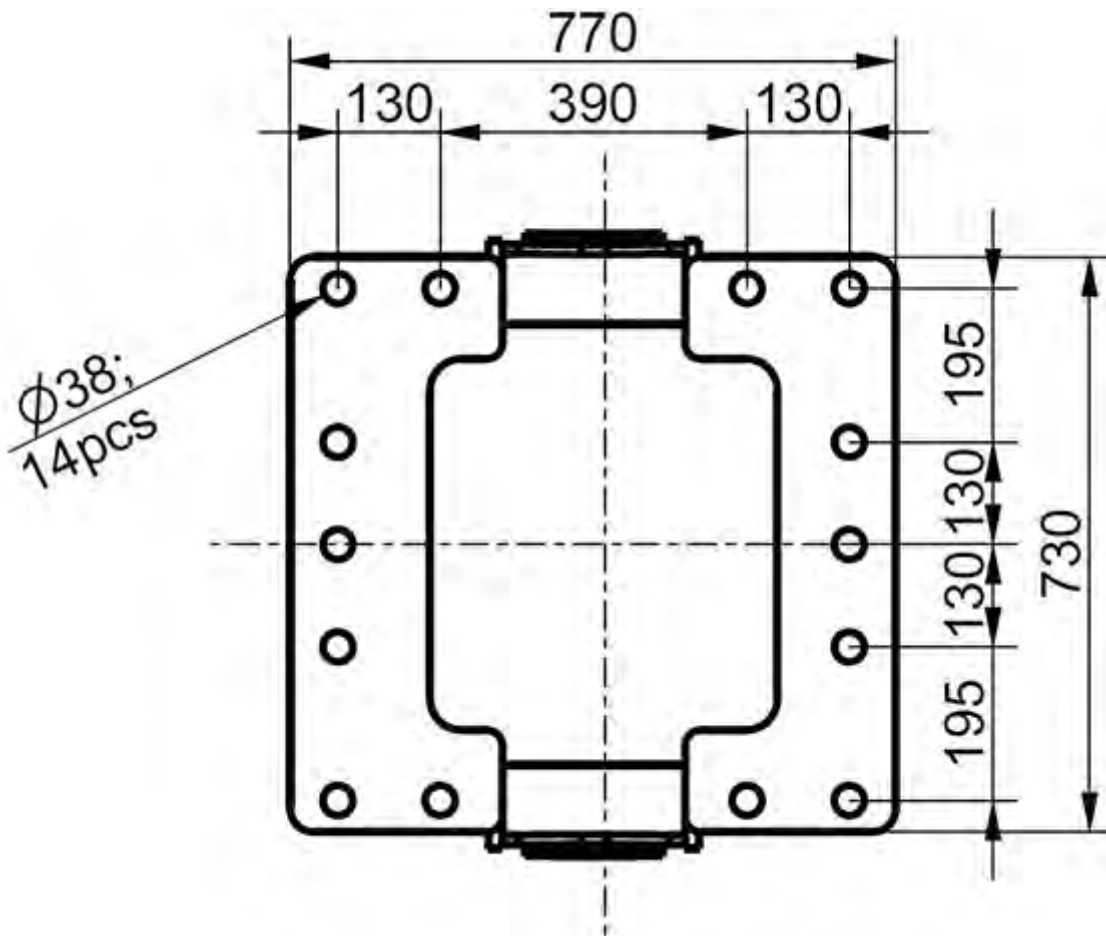
**TOP VIEW XB56**



## TOP VIEW XB102

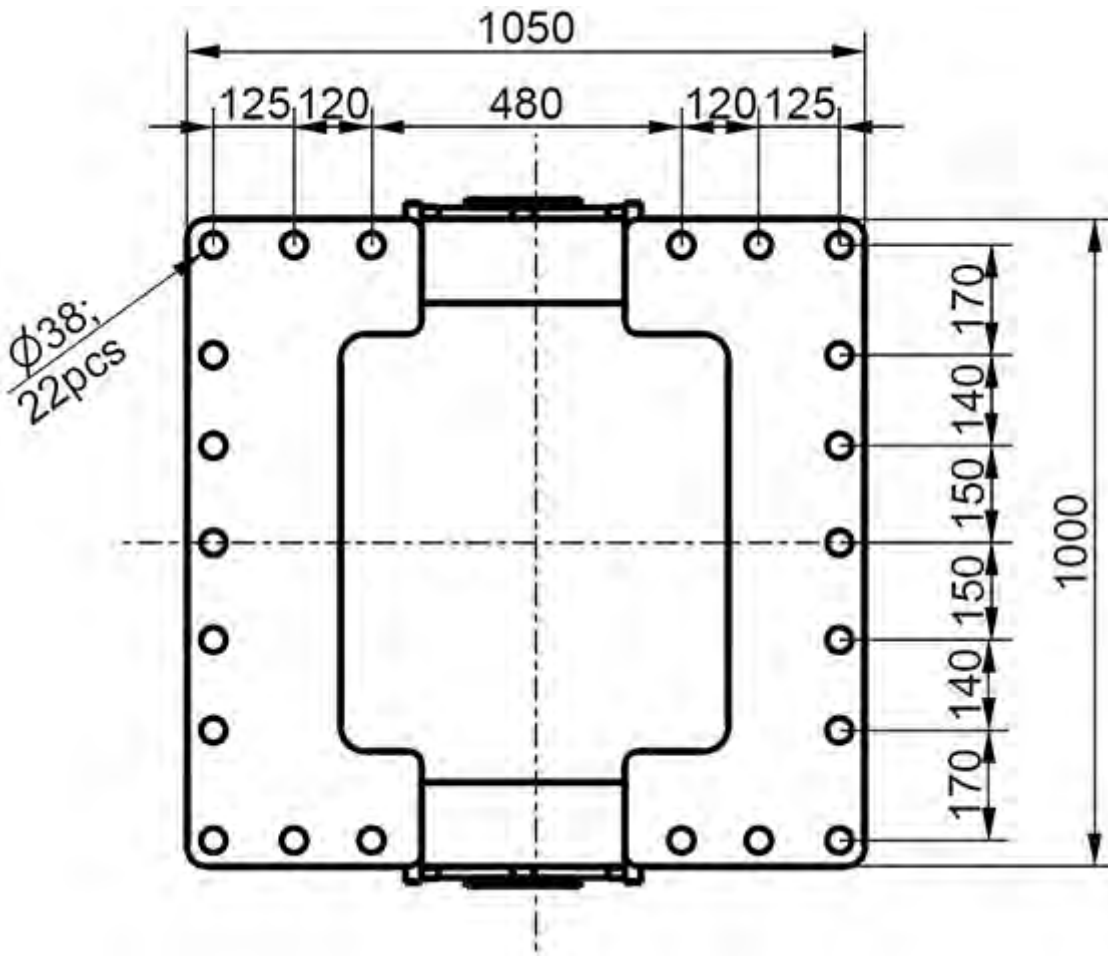

**OPERATING WEIGHT**

XB27 weight	1980 kg
Excavator weight	22 000 - 29 000 kg
XB32 weight	2350 kg
Excavator weight	26 000 - 32 000 kg
XB36 weight	2650 kg
Excavator weight	32 000 - 39 000 kg
XB45 weight	3150 kg
Excavator weight	35 000 - 45 000 kg
XB56 weight	4050 kg
Excavator weight	45 000 - 55 000 kg
XB66 weight	4750 kg
Excavator weight	50 000 - 65 000 kg
XB102 weight	7200 kg
Excavator weight	65 000 - 100 000 kg

final machine weight variate in agree with selected options

## SERVICES

### NORMET SERVICES

Normet is committed to servicing its customers all over the world. We provide service from a single machine to an entire fleet. The Normet service offering consists of many different products from delivery of parts and training to fleet performance agreements.

More information check [normet.com](https://www.normet.com):

<https://www.normet.com/en/products-and-services>

**For any questions about Normet Services contact local Normet.**

<https://www.normet.com/en/contact/>

### SPARE PARTS

As a leading global Original Equipment Manufacturer, we are committed to providing a complete solution to your spare parts needs. All of Normet's spare parts are manufactured to the highest possible standards to help maintain the safety and profitability of your projects. Our spare parts improve efficiency and total cost of ownership throughout your operations.

**Spare part recommendation / Start-up Spare Part package:** Normet Xrock products have service kits available for commissioning, 2-year and 4-year operation and most critical parts.

### SERVICE AGREEMENTS

Service agreements are always customized to meet our customer needs, consisting of various Normet service products. The service solution is created together with the customer and the level of an agreement can vary with different support agreements (including e.g. parts, periodical maintenance, on-call services, and audits) up to guaranteed fleet availability or process performance (including e.g. parts, all maintenance activities, operator trainings and process audits).

Note that we can provide Digital solutions with connected equipment.

More information check [normet.com](https://www.normet.com).

### TRAININGS

Range from equipment service training to process application training.

We offer a sustainable training path from the beginning of your operation to the execution stage of your project.

More information check [normet.com](https://www.normet.com).

### COMMISSIONING

Equipment commissioning concerns **equipment familiarization**. This is included as part of Normet vehicle delivery. Safety introduction and operating basics for Normet Equipment. Review of Normet user and spare parts manuals. Hands-on equipment safety device operational training. Ensure product quality and customer satisfaction during handover.

**Commissioning includes machinery handover to customers and safety operating principles** without technical insights or process application training.

### EXTENDED COMMISSIONING

We offer an extended training package on top of standard commissioning. Normet provides extended commissioning services that offer basic insights into maintenance manuals, periodical and daily maintenance, as well as modern operating perspectives to maximize handling efficiency. Safety-oriented training ensures reliable operations for Battery Electric Vehicles and Diesel-Driven based on your vehicle fleet. This cost-effective solution covers the essential aspects of equipment operation, safety, and maintenance schedules.

To ensure continuous and maximized safe operations with your new equipment and to expand your knowledge scale of operations, this option is the most suitable and recommended option for extending your new equipment training. This cost-effective solution covers the essential aspects of equipment operation, safety, and maintenance schedules.

### UPGRADES AND MODIFICATIONS

We build our machines to last. We also understand that your needs on the ground can change - and reacting to that change makes a big difference in your productivity. Normet Upgrades & Modifications provide you with access to product improvements that meet your evolving requirements and let you stay one step ahead of the curve.

Contact your local Normet office for Upgrade offering to your fleet.

More information check [normet.com](https://www.normet.com).

