



Breaker Boom X86-340R



Normet reserves the right to change
this specification without further notice

Pictures may include options and additional equipment.

INTRODUCTION

Xrock X86-340R is specified for low profile applications where the size matters. Horizontally arranged stick boom and tailored boom motion gives good reach in a small package.

The boom structures are designed for heavy duty in grizzly applications. The maximum reach for the boom is 3.3 m in breaker vertical position.

Xrock X86-340R boom is designed to carry hydraulic breakers from 280 kg to 610 kg and especially tailored for Normet Xrock XB5 and XB6 breakers. The system is powered by Normet Xrock Hydraulic power units which are streamlined to fit for the Normet Xrock breaker and the boom.

SLEW RING WITH ROBUST PEDESTAL

X86-340R is a 360 deg slew ring boom. The pedestal area is protected to provide high utilization even in very harsh conditions.

The pedestal size has been optimized to meet the tight space conditions without compromising the boom performance.



normet

XROCK®

POWER UNITS

All Normet Xrock power units offer a streamlined power resource for breaker booms and breakers to maximize the performance. The Power units are modular systems with wide access points for service. Power unit motor control panels are PLC controlled. All electric connections and panels are IP65 rated.

Power units have minimum 110 % capacity integrated trip drays for hydraulic oil to meet environmental regulations and avoid oil leakages. The system can be equipped with an automatic fire extinguisher.



RELIABLE CONTROL SYSTEM AND ELECTRONICS

The boom is controlled by accessorial radio remote control.

All exposed control components are IP65 rated. Cables and connections between boom, radio controller and power unit are designed for harsh mining environment.



AVAILABILITY FOR STATE-OF-THE-ART AUTOMATION



All Normet Xrock breaker booms have availability for Xrock® Automation platform. Xrock® Automation system optimizes the mine's processes in a responsible way and gives you the time to focus on anticipating and developing your business.

Xrock® Automation lets operators' control everything ergonomically from the safety of a control room. The Xrock® Automation system itself is specifically designed to be user-friendly: it's easy to learn and intuitive to use, so users will quickly get acquainted with productive work. Boom operation, management and diagnostics are available straight from the control station.

All Xrock® Automation platforms are made flexible and scalable to the mine's current and future demands. As your business grows and develops, we'll deliver you readily available solutions straight from the shelf.

CONTROL STAND

The X86-340R boom system is also available with hydraulic control stand. The hydraulic controls provide economical and reliable solution in operation from single standing position.

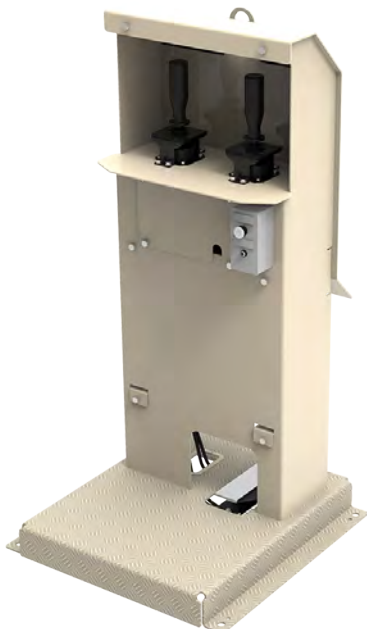

TECHNICAL SPECIFICATION

BOOM

Maximum reach (incl. nominal breaker), m	4.4
Horizontal reach, max (breaker vertical), m	3.2
Vertical reach, max (incl. nominal breaker), m	1.6
Nominal breaker length, m	1.7
Lift boom length, m	1.25
Dipper boom length, m	2.05
Welded high tensile steel plate structure	
Reinforced swivel points	
Heat treated multi alloy steel pins	
Special bronze bushings with grease depots	

PEDESTAL

Welded steel plate structure	
Slewing ring with internal gear	
High torque hydraulic motors (2 pcs.)	
Slew angle	360°
Foundation plate width	0.8 m
Foundation plate length	0.8 m

BREAKER

With boom specified configuration	
Recommended Normet Breakers:	
XB5	
XB6	
Boom installed breakers includes 1 pcs. blunt tool, Idle blow protection standard on XB11 and above breaker models.	
Recommended weight	280 - 610 kg

CONTROL SYSTEM

Control valve with 4 proportional sections and 1 on/off section to control:	
Boom movements	
Breaker	
Five mechanical control levers on the main control valve.	
Can be equipped with a Radio control unit sold as an accessory.	

Normet reserves the right to change this specification without further notice

HYDRAULIC SYSTEM

Power unit PU18

Cylinders:

Double acting cylinders with self-aligning maintenance-free bearings

Easily replaceable seals

Max. pressure 25.0 MPa

X86-340R

Hoist	100/56-400 mm
Dipper	100/56-590 mm
Breaker tilt	80/45-340 mm
Hydraulic lifting force	10 kN

POWER UNIT

Constant displacement gear pump	
Tank with 110% drip tray, service hatch and oil level indicator	
Oil filtration	10 µm
Pressure line filter clogging indicator	
Electric oil level switch	
Thermostat controlled air cooler for oil with 0.25 kW fan	
Oil pressure gauge	0-25.0 MPa
Pressure relief valve	23.0 MPa

PU18-34

Pump displacement	43 cc
Pump capacity at 1500 rpm	65 l/min
Pump capacity at 1800 rpm	78 l/min
Oil tank	250 l

REMOTE CONTROL SYSTEM

Wireless remote control with 2 joysticks and cable support

The following machine components can be controlled by radio remote control:

- Boom slew left/right
- Boom lift up/down
- Boom stick in/out
- Breaker tilt in/out
- Breaker on/off
- Power unit start/stop

Pictures may include options and additional equipment.

ELECTRICAL SYSTEM

Mains supply voltage:

- 50 Hz
 - 380 V (IEC)
 - 400 V (IEC)
 - 415 V (IEC)
 - 420 V (IEC)
 - 525 V (IEC)
 - Special voltage
- 60 Hz
 - 440 V (IEC)
 - 460 V (IEC)
 - 480 V (IEC)
 - 480 V (cULus)
 - 575 V (IEC)
 - 575 V (cULus)
 - Special voltage

Flange mounted squirrel cage electric motor:

	1500 rpm (50 Hz)	1800 rpm (60 Hz)
PU18-43	18 kW	22 kW

TECHNICAL DOCUMENTATION

Standard documents:

Instruction manuals, hard copy 1 pcs:

- English
- Russian
- One of destination EU languages

Spare parts manuals, hard copy 1 pcs:

- English

PDF manuals on USB-stick 1 pcs, includes instruction and spare parts manuals

Boom placement drawing superimposed customer's plant lay-out drawing

Dimensional (G.A.) drawings

Coverage drawing

Pedestal load data table

Foundation plate drawing

Additional documentation:

- Other than standard language manuals

ACCESSORIES

MAIN ACCESSORIES

- PU18-43 Power unit
- XB5 (X5LB) Hydraulic Breaker
- XB6 (XB6LB) Hydraulic Breaker
- Wireless remote control
 - 434 MHz
 - 458 MHz (US, Canada, Mexico)
- Hydraulic control unit

One Power unit and one Breaker can be selected for the boom.

Wireless and Hydraulic control can not be selected together.

Boom installed breakers include 1 pcs. blunt tool. Idle blow protection standard on XB11 and above breaker models.

PROCESS PRODUCTIVITY

- Automatic lubrication system
- Manual lubrication system
- Automatic breaker lubrication system
- Off-line oil filtering system

Automatic and Manual lubrication cannot be selected together.

SAFETY (BOOM)

- Slew limiter kit
- Boom limiter kit

SAFETY (POWER UNIT)

- Fire extinguisher system

COLD CLIMATE ACCESSORIES (POWER UNIT)

- Oil heater
- Oil circulation valve

OTHER ACCESSORIES

- Extended hydraulic hoses, 12 m
- Extended control cable, 20 m
- Extended valve control cable, 12 m
- Special voltage
- Special motor

Tropical motor, special insulation, above 2000 m M.A.S.L. etc..

DIMENSIONS

SIDE VIEW & REACH AREA X86-340R

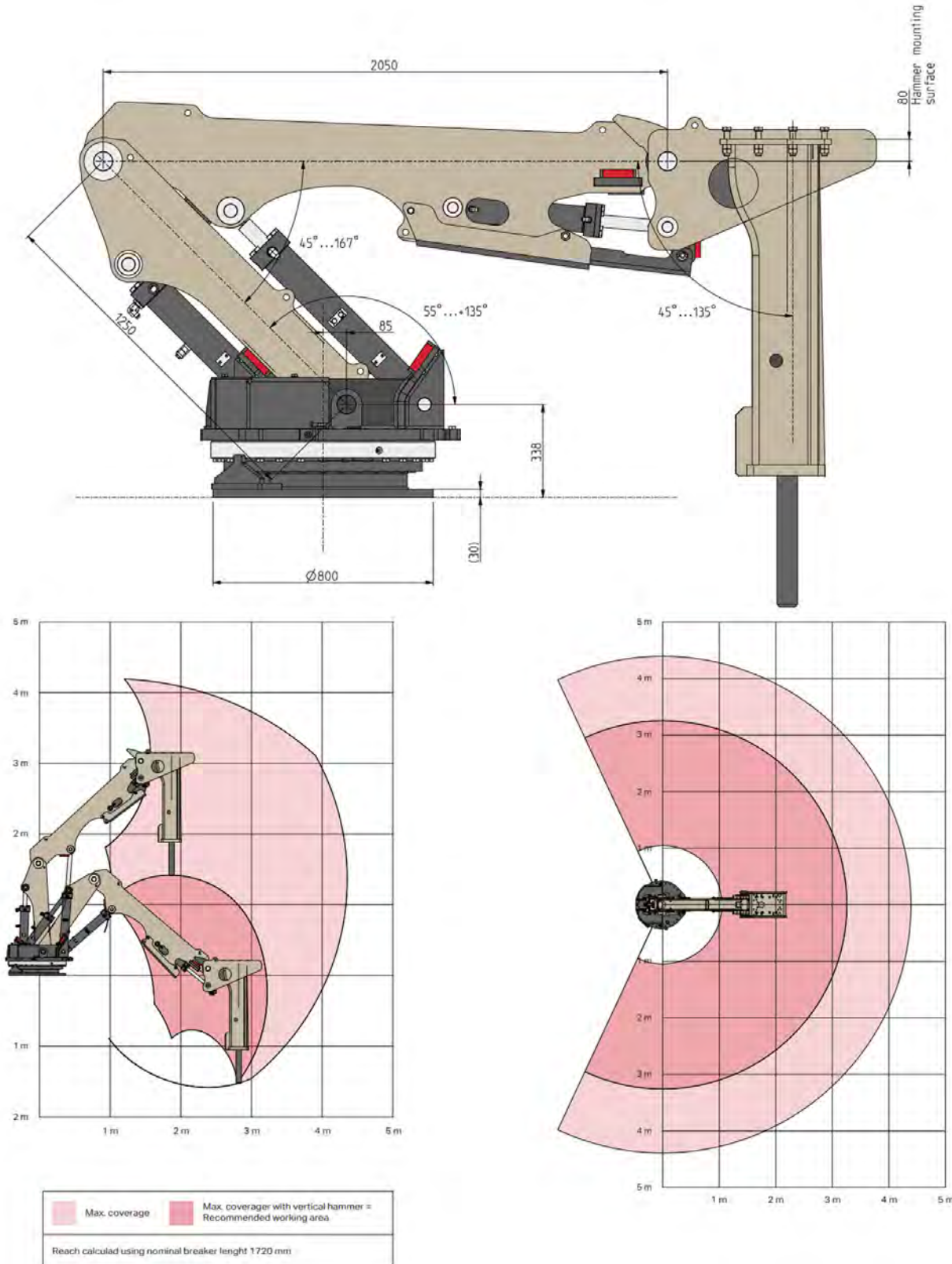

Normet reserves the right to change this specification without further notice

Pictures may include options and additional equipment.

SIDE VIEW POWER UNIT

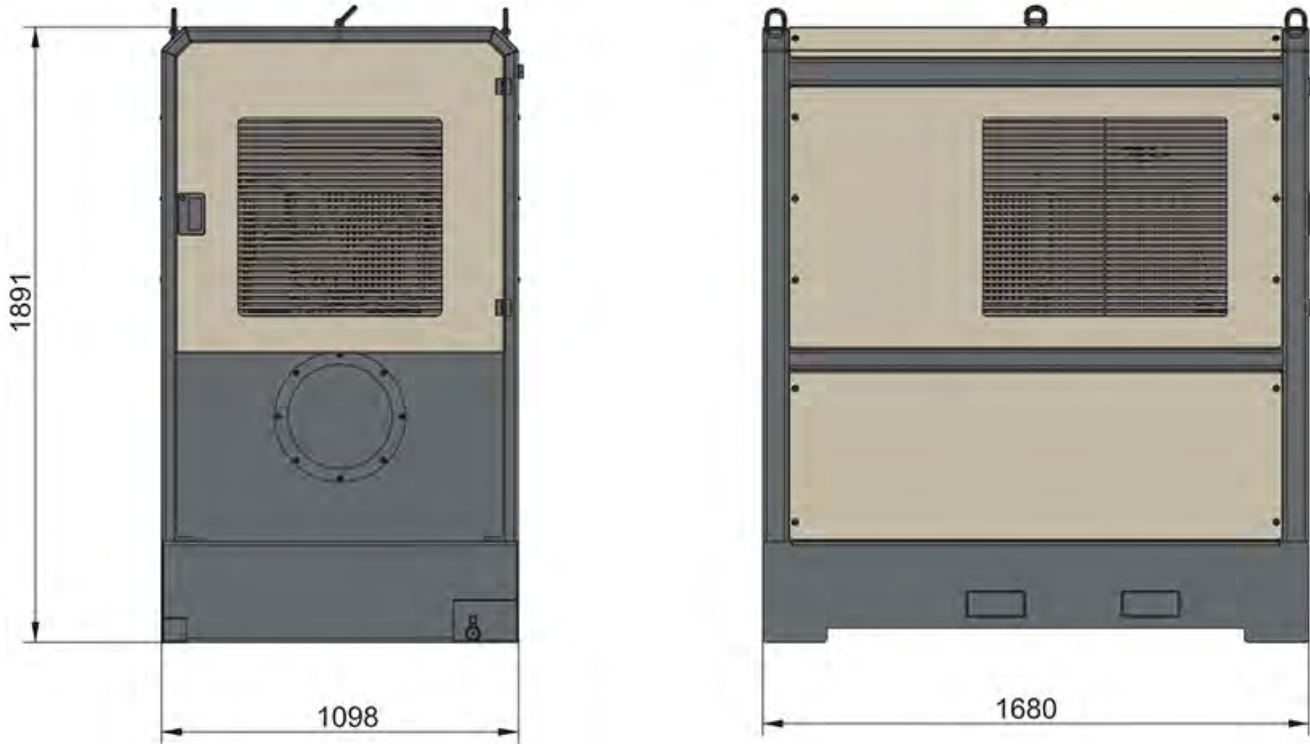

TOP VIEW POWER UNIT

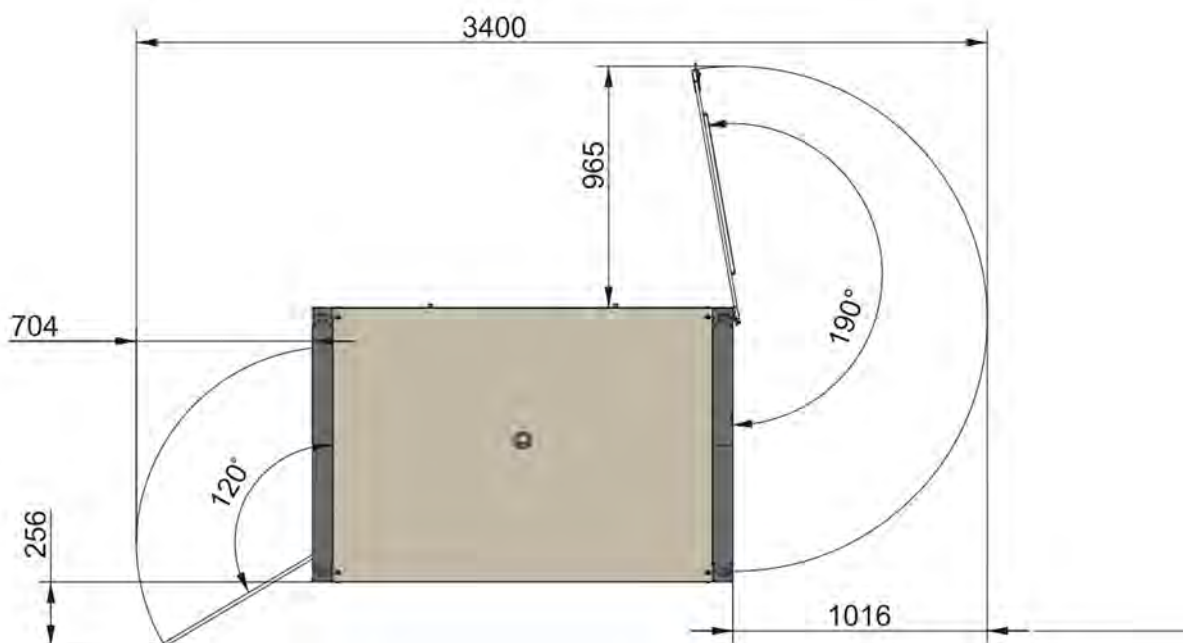

Normet reserves the right to change this specification without further notice

Pictures may include options and additional equipment.

BOTTOM VIEW POWER UNIT

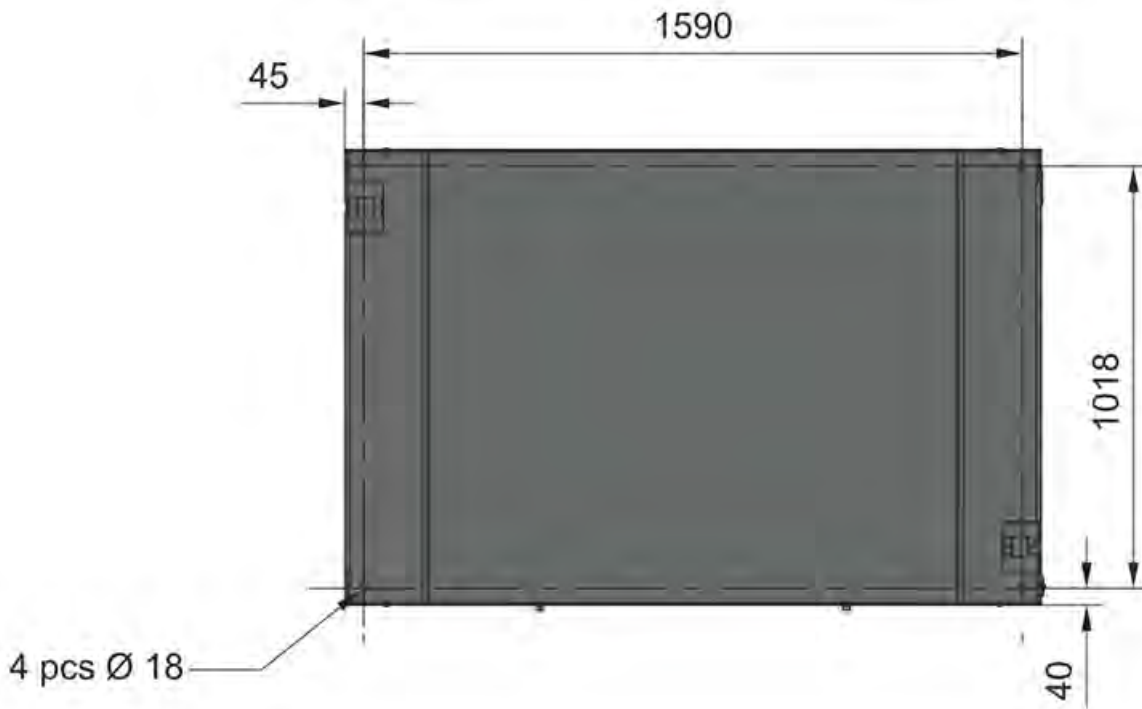

OPERATING WEIGHT (WITHOUT BREAKER)

Base machine X86-340R 1310 kg

Power unit (without oil):

Base machine PU18-43 800 kg

final machine weight variate in agree with selected options

SERVICES

NORMET SERVICES

Normet is committed to servicing its customers all over the world. We provide service from a single machine to an entire fleet. The Normet service offering consists of many different products from delivery of parts and training to fleet performance agreements.

More information check [normet.com](https://www.normet.com):

<https://www.normet.com/en/products-and-services>

For any questions about Normet Services contact local Normet.

<https://www.normet.com/en/contact/>

SPARE PARTS

As a leading global Original Equipment Manufacturer, we are committed to providing a complete solution to your spare parts needs. All of Normet's spare parts are manufactured to the highest possible standards to help maintain the safety and profitability of your projects. Our spare parts improve efficiency and total cost of ownership throughout your operations.

Spare part recommendation / Start-up Spare Part package

Normet Xrock products have service kits available for commissioning, 2-year and 4-year operation and most critical parts.

SERVICE AGREEMENTS

Service agreements are always customized to meet our customer needs, consisting of various Normet service products. The service solution is created together with the customer and the level of an agreement can vary with different support agreements (including e.g. parts, periodical maintenance, on-call services, and audits) up to guaranteed fleet availability or process performance (including e.g. parts, all maintenance activities, operator trainings and process audits).

Note that we can provide Digital solutions with connected equipment.

More information check [normet.com](https://www.normet.com).

TRAININGS

Range from equipment service training to process application training.

We offer a sustainable training path from the beginning of your operation to the execution stage of your project.

More information check [normet.com](https://www.normet.com).

COMMISSIONING

Equipment commissioning concerns **equipment familiarization**. This is included as part of Normet vehicle delivery. Safety introduction and operating basics for Normet Equipment. Review of Normet user and spare parts manuals. Hands-on equipment safety device operational training. Ensure product quality and customer satisfaction during handover.

Commissioning includes machinery handover to customers and safety operating principles without technical insights or process application training.

EXTENDED COMMISSIONING

We offer an extended training package on top of standard commissioning. Normet provides extended commissioning services that offer basic insights into maintenance manuals, periodical and daily maintenance, as well as modern operating perspectives to maximize handling efficiency. Safety-oriented training ensures reliable operations for Battery Electric Vehicles and Diesel-Driven based on your vehicle fleet. This cost-effective solution covers the essential aspects of equipment operation, safety, and maintenance schedules.

To ensure continuous and maximized safe operations with your new equipment and to expand your knowledge scale of operations, this option is the most suitable and recommended option for extending your new equipment training. This cost-effective solution covers the essential aspects of equipment operation, safety, and maintenance schedules.

UPGRADES AND MODIFICATIONS

We build our machines to last. We also understand that your needs on the ground can change - and reacting to that change makes a big difference in your productivity. Normet Upgrades & Modifications provide you with access to product improvements that meet your evolving requirements and let you stay one step ahead of the curve.

Contact your local Normet office for Upgrade offering to your fleet.

More information check [normet.com](https://www.normet.com).

