



# Variomec XS 035 Crew



Normet reserves the right to change  
this specification without further notice

Pictures may include options and additional equipment.

## INTRODUCTION



**Variomec XS 035 Crew** is a purpose-built and agile vehicle for material and people transportation in 3.5 m x 3.5 m or bigger tunnels. Vehicle has 3.5 tn material carrying capacity and personnel compartment up to 3 passengers. Variomec XS offers roomy platform with low loading height and it is possible to equip with several different optional equipment to increase machine versatility.

XS-series is designed to operate small size tunnels with bigger load capacity compared to current light vehicles commonly used in underground mines. XS-series offers totally new level of safety, ergonomic and total cost of ownership while retain good performance, payload capacity and mobility of the existing fleet.

**Versatile XS-carrier** have unique fast connecting load end structure, which enables to utilize one carrier for multiple processes, like:

- Material deck with optional crane
- Crew application with material deck and compartment up to 3-persons
- Personnel compartment up to 11 passenger

Basic carrier have readiness for all load end applications and changing the application takes couple hours.

Normet XS series have powerful Deutz Tier 3 approved diesel engine and reliable Linde hydrostatic transmission.

Vehicle has a full chassis suspension system that improves driving safety, comfort and reduces fatigue. The suspension system gives efficiency and speed to vehicle usage, with safety and comfort for the driver and the passenger.

Normet FOPS and ROPS approved safety cabin provides superior visibility and comfortable compartment for the driver and the passenger. Cabin is designed for safe and easy entry and exit. Door openings are wide and handrails and non-slip step are correctly positioned. Dashboard is easy and simple to use and the multi-informational display (MID) provides all necessary information for operator, like speed, operating hours, temperatures, safety alarms and warnings. All the information can be recorded for further analysis.

NorSmart 3 electric and control system is designed for harsh underground environment. Electric system consist self-extinguishing wire harnesses with tinned and water tight conduits. In addition, all exposed components are rated at least IP65 class.

Vehicle layout allows easy access to all service points and all daily checks can be done from the ground level.

# TECHNICAL SPECIFICATION

## MATERIAL PLATFORM

Carrying capacity	3500 kg
Platform inner dimensions	2040 mm x 1680 mm
Loading height	1005 mm
Openable and removable edges	
Height	425 mm

## PERSONNEL COMPARTMENT

Enclosed personnel compartment FOPS/ROPS approved

- Fresh air blower
- Heating
- Air conditioning

Seats

- Suspended seats with 3 point seat belts for 3 persons
- Benches with retractable lap seat belt for 4 persons

## ENGINE AND TRANSMISSION

**Deutz TCD 2012 L4, 96 kW/2200 rpm, Tier 3 / Stage IIIA approved**

Exhaust system for Deutz engine:

- Catalytic exhaust gas purifier and muffler
- Catalytic converter (DOC) & Diesel particulate filter (DPF)

Fuel tank capacity 110 l

**Linde hydrostatic transmission**

Pump	105 cm <sup>3</sup>
Motor	210 cm <sup>3</sup>

4-wheel drive

## PERFORMANCE

Tramming speed (horizontal) 30 km/h

Lateral gradient for tramming (continuous) 4°

Longitudinal gradient for tramming (continuous) 9°

Depending of machine configuration, lateral and longitudinal tramming gradient can temporarily be higher.

## AXLES AND BRAKES

Dana 212 Planetary type axles

Hydraulically powered dual-circuit oil immersed multidisc service brakes in both axles

Spring applied hydraulically released fail-safe -type parking/safety brakes in both axles

Leaf spring suspended chassis

## TYRES AND RIMS

Tire size:

- 9.00-20
- 8.25-15 (100 mm lower machine)

## STEERING

4-wheel steering with three steering modes

Front axle steering, concentric 4 WS and crab walk

Orbitrol type

## HYDRAULIC SYSTEM

Variable displacement pump system:

190 bar, 90 l/min at 2200 rpm

Hydraulic oil tank capacity 100 l

## 24 VDC ELECTRICAL SYSTEM

LED driving and indicator lights

LED work lights

LED side lights

Warning LED light:

Color

- Amber
- Blue
- Red
- Green (n/a with rotating light pattern)
- White (n/a with rotating light pattern)

Light pattern

- Strobe
- Rotating

## DRIVER'S COMPARTMENT

Enclosed cabin, FOPS/ROPS approved

- Fresh air blower
- Heating and A/C

Driver's seat and seat belt:

Mechanically suspended T-back seat with 3-point seat belt

Cabin door interlock switches with safety brake application

Passenger's seat:

- Mechanically suspended T-back seat with 3-point seat belt
- 2 seats with 3-point seat belts

## MACHINE CONNECTIVITY

- Machine connectivity hardware (WLAN/3G/4G/LTE)
- Data lifetime license (Include connectivity hardware)
- Analytics lifetime license (Include connectivity hardware and data lifetime license)

## TECHNICAL DOCUMENTATION

Standard documents:

Instruction manuals, hard copy 2 pcs:

- English
- Russian
- One of destination EU languages

Spare parts manuals, hard copy 2 pcs:

- English
- Russian

PDF manuals on USB-stick 2 pcs, includes instruction and spare parts manuals

Additional documentation:

- Extra hard copies of manuals
- Extra PDF manuals
- LinkOne WebView electronic manuals
- Other than standard language manuals

## OTHER

6 kg hand held extinguisher

Painting and taping:

- Standard painting and taping
- Painting and taping according to customer specifications

Text labels in:

- En/Ru/One of destination EU languages
- Other language

Measurements:

- Noise
- Vibration
- Emissions

Normet reserves the right to change this specification without further notice

Pictures may include options and additional equipment.

## ACCESSORIES

### PROCESS PRODUCTIVITY

- Communication system between cabin and personnel compartment
- Guard grills for personnel compartment windows
- Door interlock switches for personnel compartment
  - Warning signal for driver
  - Safety brake application
- HEPA filter for personnel compartment
- Crane 9 kNm
- Welding generator 6 kVa
- Individual lube unit with pneumatic pump, meter and hose reel 100 l
- Hydraulic driven air compressor 0,4 m<sup>3</sup>/min
- Hydraulic driven pressure washer
  - Water tank 100 l
- Draw ball 50 mm
- Towing capacity 2000 kg
- Electric connection 24 V
- RUS hook
- Towing capacity 2000 kg

### CARRIER PRODUCTIVITY

- Audio system
- Two-piece windscreen
- HEPA filter for driver's compartment
- Heated mirrors
- 12 V 20 A power supply in cabin with socket and connector
- Reversing camera
  - 1 camera, 1 display
  - 3 cameras, 2 displays
  - 4 cameras, 1 display and OACR/VCR recording system with 72 h memory
- Spare rim and tyre
- Toolbox and maintenance tools
- Auto engine shut down during idling
- Engine shut down delay
- Block heater with interior heater and battery charger
- Fuel operated engine pre-heater
- Inlet plug for jump start
- Fast fuel filling system
- Automatic lubrication system
- Fluid evacuation panel with sampling points
- Wax tape for electric connectors
- Interior cooling fan
- Hand pump for hydraulic tank filling

### SAFETY

- Ansul A-101 fire extinguisher system
  - Manual
    - Automatic, Checkfire 110
- Extra 6 kg hand held fire extinguisher
- Seat belt interlock switch applies safety brake
- Flash light with charger
- Cabin door puddle lights
- Grounding chain
- Hearing protectors
- Warning triangles
- Pump for brake release
  - Electric pump
  - Hand pump
- Redundant brake monitoring system
- Extra warning LED light
- Color
  - Amber
  - Red
  - Blue
  - Green (n/a with rotating light pattern)
  - White (n/a with rotating light pattern)
- Light pattern
  - Strobe
  - Rotating
- Tyre pressure indicators
- Protection guards for tunnel curtains
- Methane monitoring system
- Wheel chocks with brackets
- Service isolator for starter
- Direction lights (Green/Red)



## SERVICES

### NORMET SERVICES

Our services cover the whole life cycle of your equipment. They include start-up and commissioning, genuine spare parts, upgrades & modifications, and remanufacturing, as well as rental and leasing offerings, and field services. We also offer improvement services such as operator training and process audits.

### SPARE PARTS

Genuine parts from Normet Services ensure that you always have the highest quality parts available to keep your equipment up and running. Depending on your needs, we can offer everything from individual parts to complete parts contracts, and our professionals around the world have the experience to ensure that you have the parts you need when you need them.

#### Initial spare parts package:

Available for 1000h of use\*. Includes periodical service, most common wearing parts and most critical safety parts.

#### Spare parts packages made for customer needs:

Available based on hours of use\*. Includes periodical service, most common wearing parts and most critical safety parts.

\* Recommendations are based on average hours – can vary a lot depending on work site conditions.

### UPGRADES AND MODIFICATIONS

Our Upgrades and Modifications services are designed to ensure the economical, efficient and purposeful performance of your equipment over its entire life cycle. A service provided by a reliable OEM like Normet ensures the safety and performance of your equipment. Normet Upgrades and Modifications save you both time and money, while delivering the high quality you expect from us.

### SERVICE CONTRACTS

With a service agreement, Normet manages your fleet with guaranteed availability and agreed costs, giving you transparency for your life cycle costs, annual operational budget and fleet uptime. This lets you focus on your core operations. Each service agreement is built and customized to meet the individual customer's needs from our portfolio of services. Depending on the level of service agreement you need, you can choose anything from basic technical support for an individual machine all the way up to services for your entire fleet, as well as process performance. The service levels we offer are:

- Parts Availability
- Fleet Support
- Fleet Availability
- Process Performance

The content of a service level can be tailored to meet your particular requirements.

### TRAINING SERVICE

Our Training Services are available for you and your operators throughout the equipment lifecycle and they include:

				
	Operation & Maintenance	Spraying	Charging	Scaling
ADVANCED	Advanced fault diagnostics & troubleshooting	Concrete chemicals, testing and preparing for EFNARC-certificate test		
INTERMEDIATE	Troubleshooting training Foundations of electrics, hydraulics and mechanics NorSmart	Advanced training in concrete spraying Economics of concrete spraying	Advanced training in explosives Economics of charging	Advanced training in scaling Economics of scaling
BASIC	Operation and Maintenance Training Basic Product Training	Basic understanding of concrete spraying	Basic understanding of charging	Basic understanding of scaling
LEVEL	SERVICE	PROCESS KNOWLEDGE		

# START-UP AND COMMISSIONING

## 1. OPERATOR TRAINING

	Start-up training	Commissioning
<b>1.1 Classroom training</b>		
General introduction and operation of machine	Basic	No classroom training included in commissioning
Safety instructions	Basic	
Use of manuals	Basic	
Technical introduction of equipment	Basic	
Hands-on service and pre-operation checks	Basic	
Controls and driving (starting, driving, stopping, parking)	Basic	
<b>1.2 Practical training</b>		
Pre-operation checks	Basic	Introduction
Driving, starting, stopping, parking	Basic	Introduction
Preparing the machine for specific operation conditions	Basic	Not covered
Operation	Basic	Introduction
Washing the machine	Basic	Introduction
Troubleshooting	Basic	Basic

## 2. MAINTENANCE AND REPAIR TRAINING

General operation of machines	Basic	Introduction
Symbols of drawings and codes	Basic	Not covered
Understanding hydraulic and electric schematics	Basic	Introduction
Control systems	Basic	Introduction
Function of main components (depending on equipment)	Basic	Introduction
Locations of components in the machine	Basic	Not covered
Periodical maintenance	Basic	Introduction
Troubleshooting	Basic	Not covered
Use of manuals	Basic	Introduction
Connection of hydraulic and electrical equipment	Basic	Not covered

## DIMENSIONS

Length	6470 mm	Track	1760 mm
Width with 15" tires	1920 mm	Ground clearance with 15" tires	250 mm
Width with 20" tires	2050 mm	Ground clearance with 20" tires	350 mm
Height with 15" tires	2240 mm	Turning radius outer	5100 mm
Height with 20" tires	2340 mm	Turning radius inner	2050 mm
Wheel base	2750 mm		

### SIDE VIEW

Machine with 20" tires

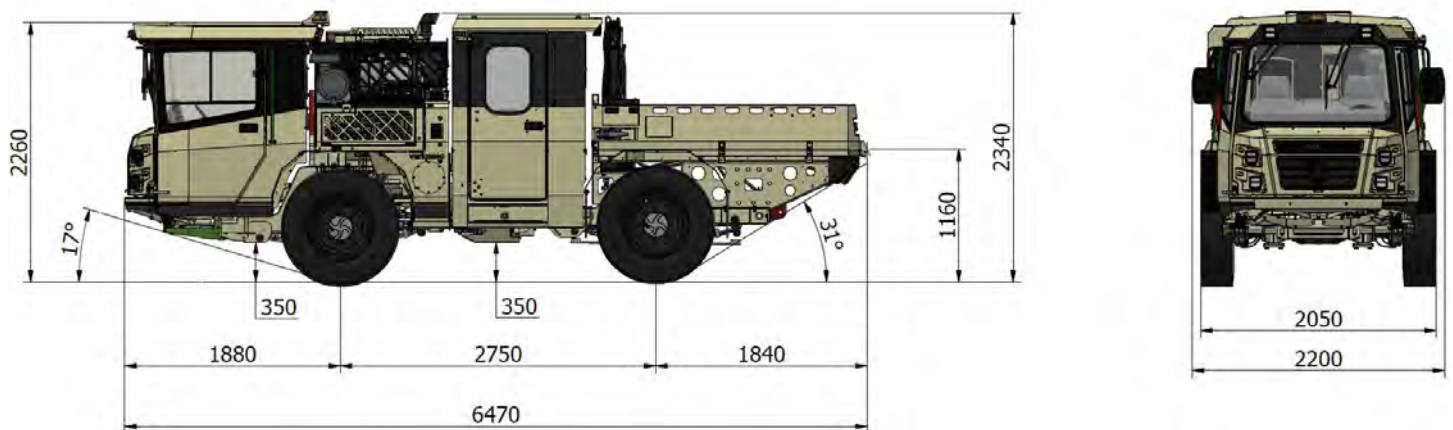

### TOP VIEW

Machine with 20" tires

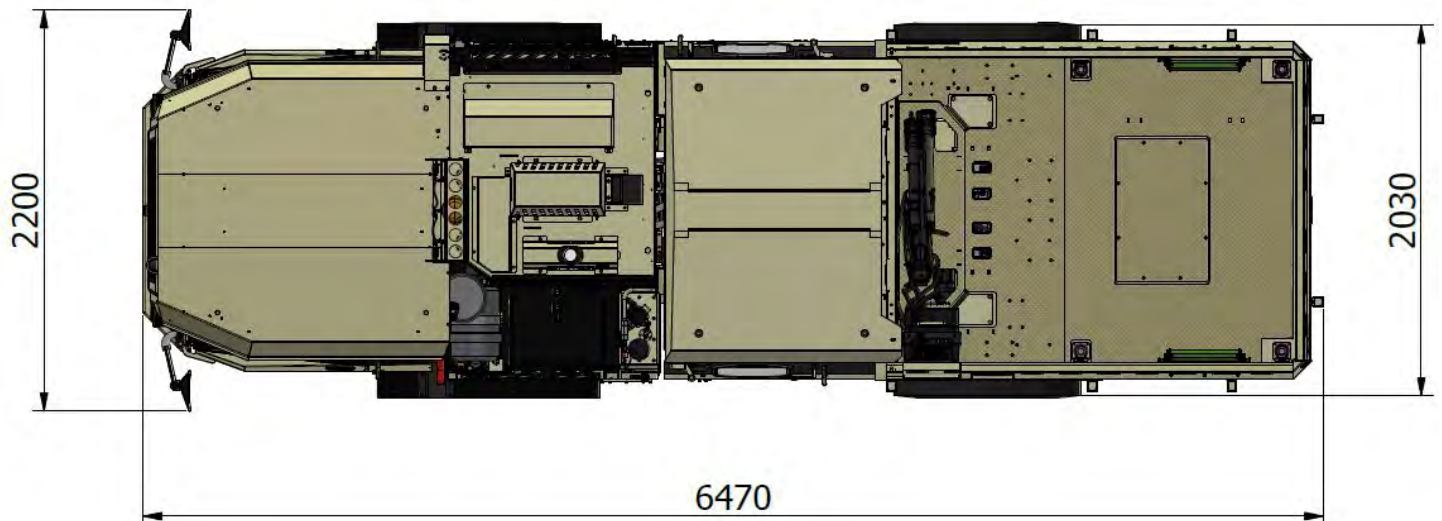



## SIDE VIEW

Machine with 15" tires

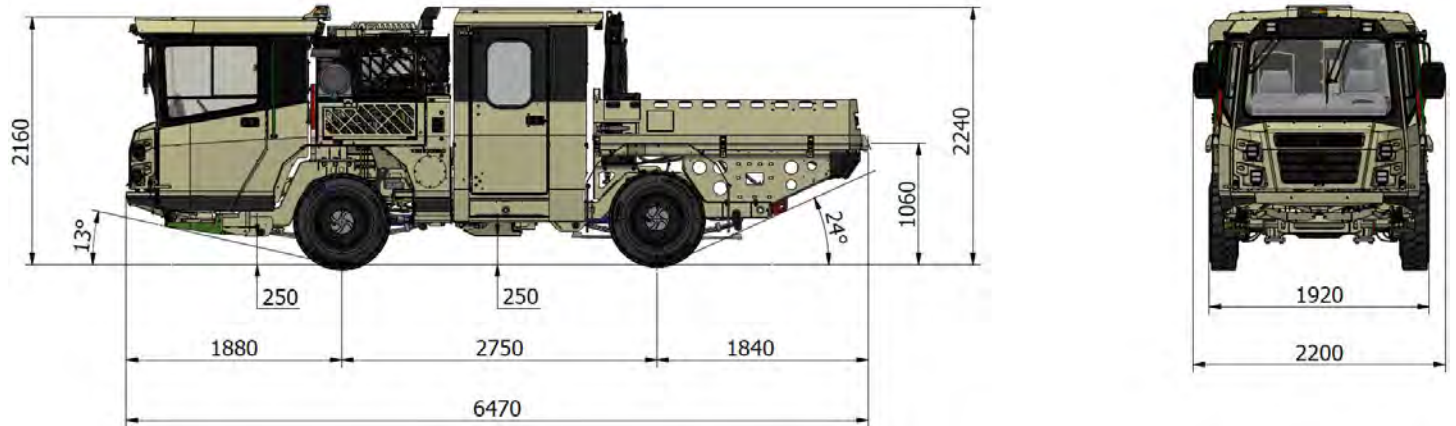

## TOP VIEW

Machine with 15" tires

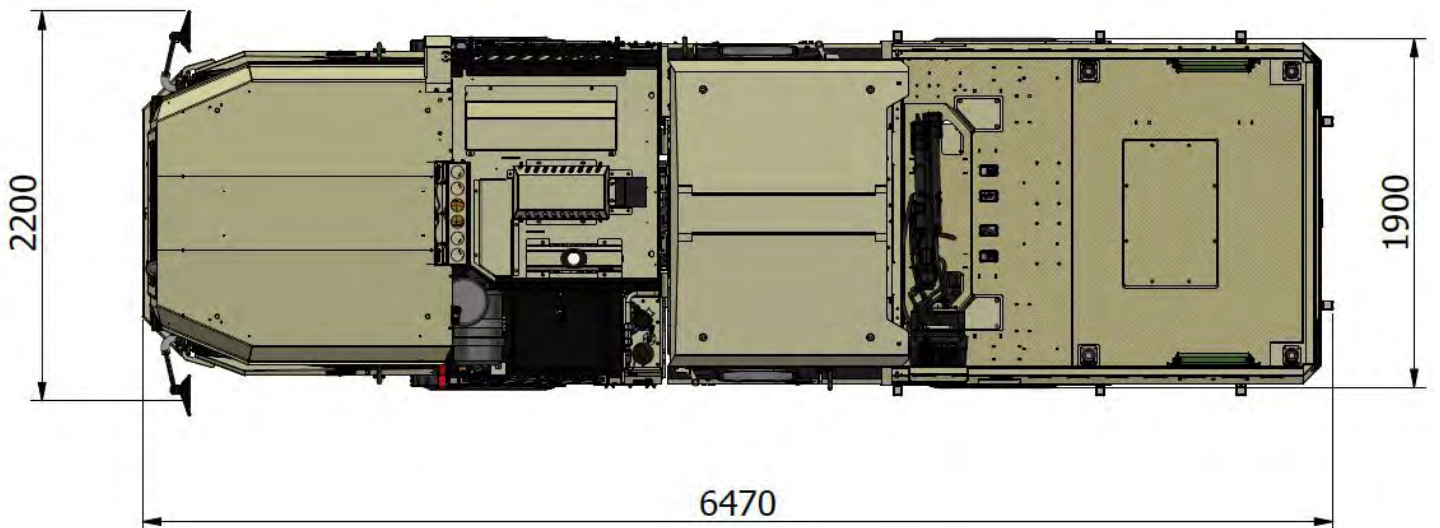

## TURNING RADIUS

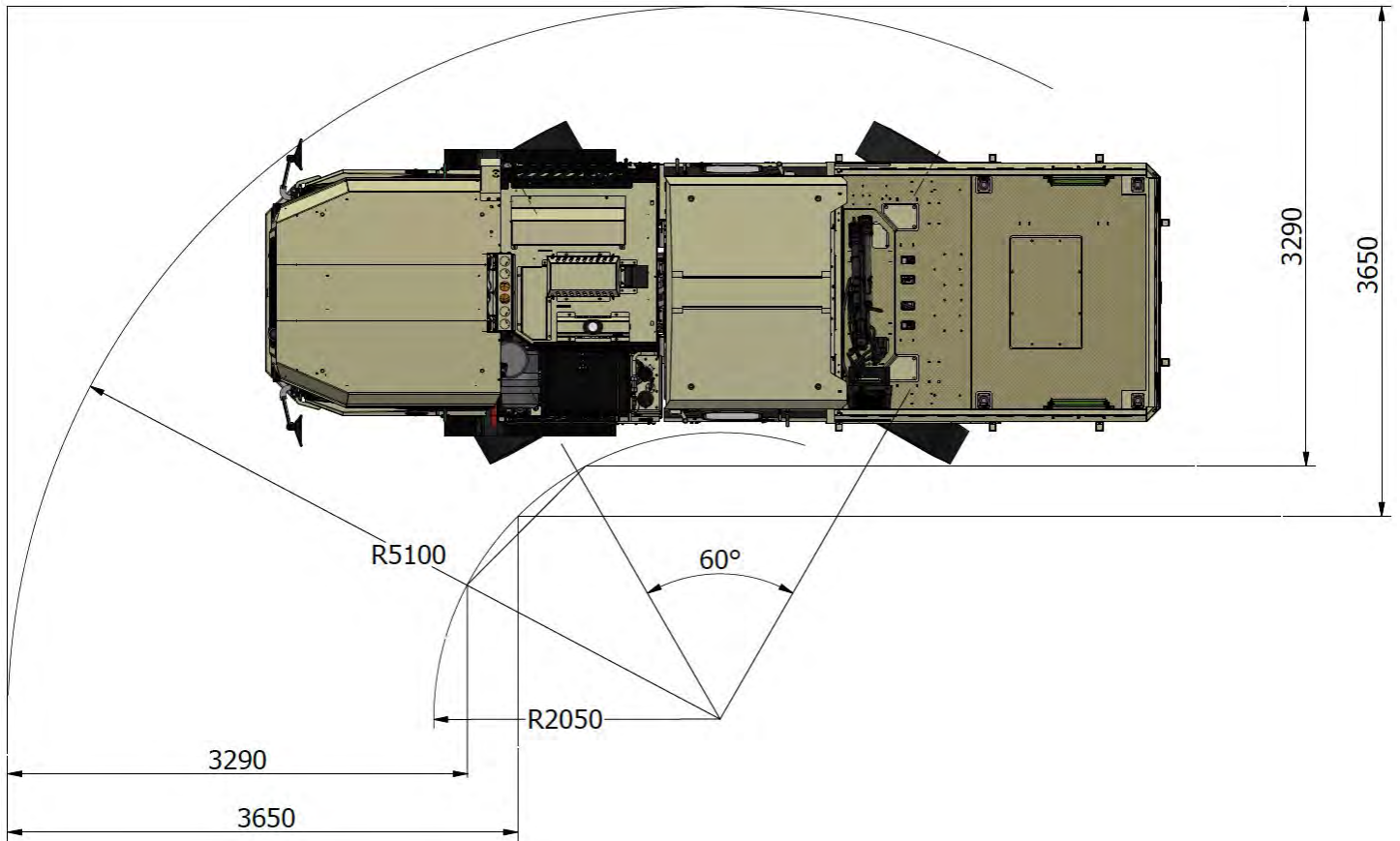

Normet reserves the right to change this specification without further notice

Pictures may include options and additional equipment.

## TRACTIVE EFFORTS

### OPERATING WEIGHT

Empty	7 500 kg
Fully loaded	11 000 kg

### DEUTZ TCD 2012 L4, 96 KW

Performance curve DOC059943

#### Conversion chart

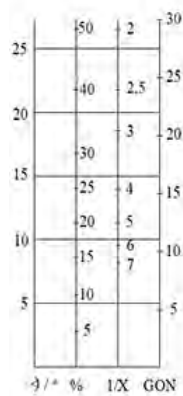

#### Gradeability kN

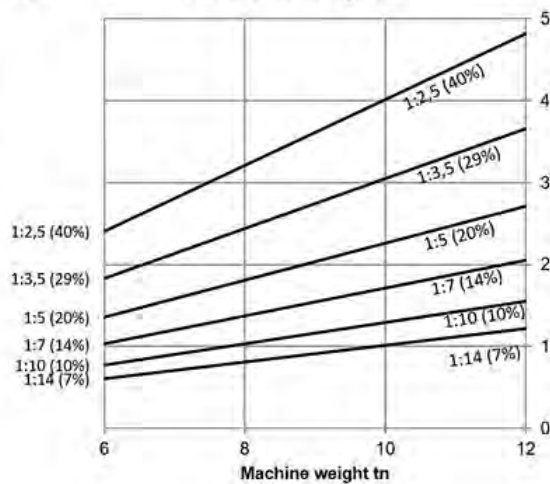

#### Tractive effort kN

