



Breaker Boom X24-Series



Normet reserves the right to change this specification without further notice

Pictures may include options and additional equipment.

INTRODUCTION

Xrock X24-Series of breaker boom is a very light weight system designed for tight spaced operations. The boom controls and range of motion ensures a flexible positioning of the pedestal especially in portable and track mounted crusher units. The X24-Series consists of two different models from 3 m horizontal reach up to 4 m.

Xrock X24-Series booms are designed to carry hydraulic breakers from 300 kg to 600 kg and especially tailored for Normet Xrock XB breakers. The system is powered by Normet Xrock Hydraulic power units which are streamlined to fit for the Normet Xrock breaker and the boom.



SLEW RING WITH ROBUST PEDESTAL

The pedestal diameter is optimized with minimal footprint. The 360 deg rotation gives freedom to design suitable boom positions for operation, park and transportation.

The pedestal size has been optimized to meet the tight space conditions without compromising the boom performance.



POWER UNITS

All Normet Xrock power units offer a streamlined power resource for breaker booms and breakers to maximize the performance. The Power units are modular systems with wide access points for service. Power unit motor control panels are PLC controlled. All electric connections and panels are IP65 rated.

Power units have minimum 110 % capacity integrated trip drays for hydraulic oil to meet environmental regulations and avoid oil leakages. The system can be equipped with an automatic fire extinguisher.



RELIABLE CONTROL SYSTEM AND ELECTRONICS

The boom is controlled by accessorial radio remote control.

All exposed control components are IP65 rated. Cables and connections between boom, radio controller and power unit are designed for harsh mining environment.



AVAILABILITY FOR STATE-OF-THE-ART AUTOMATION

XROCK[®]

AUTOMATION

All Normet Xrock breaker booms have availability for Xrock[®] Automation platform. Xrock[®] Automation system optimizes the mine's processes in a responsible way and gives you the time to focus on anticipating and developing your business.

Xrock[®] Automation lets operators' control everything ergonomically from the safety of a control room. The Xrock[®] Automation system itself is specifically designed to be user-friendly: it's easy to learn and intuitive to use, so users will quickly get acquainted with productive work. Boom operation, management and diagnostics are available straight from the control station.

All Xrock[®] Automation platforms are made flexible and scalable to the mine's current and future demands. As your business grows and develops, we'll deliver you readily available solutions straight from the shelf.



TECHNICAL SPECIFICATION

BOOM

	X24-290R	X24-420R
Maximum reach (incl. nominal breaker), m	4.7	6
Horizontal reach, max (breaker vertical), m	3	4
Vertical reach, max (incl. nominal breaker), m	2.6	3.9
Nominal breaker length, m	1.7	1.7
Lift boom length, m	1.76	1.76
Dipper boom length, m	1.25	1.25
Dipper extension boom length, m	n/a	1.25

Welded high tensile steel square pipe structure
220 x 220 mm section

Reinforced swivel points

Heat treated multi alloy steel pins with conical locking

Special bronze bushings with grease depots

PEDESTAL

Welded steel plate structure

Slewing ring with internal gear

High torque hydraulic motors (2 pcs.)

Slew angle 360°

Foundation plate width 0.8 m

Foundation plate length 0.8 m

BREAKER

With boom specified configuration

Recommended Normet Breakers:

XB5

XB6

Recommended weight 300 kg - 600 kg

CONTROL SYSTEM

Control valve with 4-5 proportional sections and 1 on/off section to control:

- Boom movements
- Breaker

5 or 6 mechanical control levers on the main control valve.

Can be equipped with a Radio control unit sold as an accessory.

HYDRAULIC SYSTEM

Power unit PU18-43

Cylinders:

Double acting cylinders with self-aligning maintenance-free bearings

Easily replaceable seals

Max. pressure 25.0 MPa

X24-290R

Hoist	160/90-350 mm
Dipper	125/70-650 mm
Breaker tilt	100/56-380 mm
Hydraulic lifting force	10 kN

X24-420R

Hoist	160/90-350 mm
Dipper 1	125/70-650 mm
Dipper 2	100/56-380 mm
Breaker tilt	100/56-380 mm
Hydraulic lifting force	6 kN

POWER UNIT

Constant displacement gear pump

Tank with 110% drip tray, service hatch and oil level indicator

Oil filtration 10 µm

Pressure line filter clogging indicator

Electric oil level switch

Thermostat controlled air cooler for oil with 0.25-0.37 kW fan

Oil pressure gauge 0-25.0 MPa

Pressure relief valve 23.0 MPa

PU18-34

Pump displacement	43 cc
Pump capacity at 1500 rpm	65 l/min
Pump capacity at 1800 rpm	78 l/min
Oil tank	250 l

PU30-63

Pump displacement	63 cc
Pump capacity at 1500 rpm	90 l/min
Pump capacity at 1800 rpm	108 l/min
Oil tank	250 l

PU37-87

Pump displacement	87 cc
Pump capacity at 1500 rpm	125 l/min
Pump capacity at 1800 rpm	150 l/min
Oil tank	250 l

PU45-121

Pump displacement	121 cc
Pump capacity at 1500 rpm	180 l/min
Pump capacity at 1800 rpm	215 l/min
Oil tank	400 l

PU55-151

Pump displacement	151 cc
Pump capacity at 1500 rpm	220 l/min
Pump capacity at 1800 rpm	265 l/min
Oil tank	400 l

REMOTE CONTROL SYSTEM

Wireless remote control with 2 joysticks and cable support

The following machine components can be controlled by radio remote control:

- Boom slew left/right
- Boom lift up/down
- Boom stick in/out
- Breaker tilt in/out
- Breaker on/off
- Power unit start/stop

ELECTRICAL SYSTEM

Mains supply voltage:

- 50 Hz
 - 380 V
 - 400 V
 - 415 V
 - 420 V
 - 525 V
 - Special voltage
- 60 Hz
 - 440 V
 - 460 V
 - 480 V
 - 575 V
 - Special voltage

Flange mounted squirrel cage electric motor:

	1500 rpm (50 Hz)	1800 rpm (60 Hz)
PU18-43	18 kW	22 kW
PU30-63	30 kW	36 kW
PU37-87	37 kW	44 kW
PU45-121	45 kW	54 kW
PU55-151	55 kW	66 kW

TECHNICAL DOCUMENTATION

Standard documents:

Instruction manuals, hard copy 1 pcs:

- English
 - Russian
 - One of destination EU languages

Spare parts manuals, hard copy 1 pcs:

- English

PDF manuals on USB-stick 1 pcs, includes instruction and spare parts manuals

Additional documentation:

- Extra hard copies of manuals
- Extra PDF manuals
- LinkOne WebView electronic manuals
- Other than standard language manuals
- Boom placement drawing superimposed customer's plant lay-out drawing
- Dimensional (G.A.) drawings
- Coverage drawing
- Pedestal load data table
- Foundation plate drawing

ACCESSORIES

MAIN ACCESSORIES

- PU18-43 Power unit
- XB5 Hydraulic breaker
- XB6 Hydraulic breaker
- Wireless remote control
 - 434 MHz
 - 458 MHz

One Power unit and one Breaker can be selected for the boom.

PROCESS PRODUCTIVITY

- Automatic lubrication system
- Manual lubrication system
- Automatic breaker lubrication system
- Off-line oil filtering system

Automatic and Manual lubrication cannot be selected together.

SAFETY (BOOM)

- Slew limiter kit
- Boom limiter kit

SAFETY (POWER UNIT)

- Fire extinguisher system

COLD CLIMATE ACCESSORIES (POWER UNIT)

- Oil heater
- Oil circulation valve

OTHER ACCESSORIES

- Extended hydraulic hoses, 12 m
- Extended control cable, 20 m
- Extended valve control cable, 12 m
- Special voltage
- Special motor

Tropical motor, special insulation, above 2000 m M.A.S.L. etc..

DIMENSIONS

SIDE VIEW & REACH AREA X24-290R

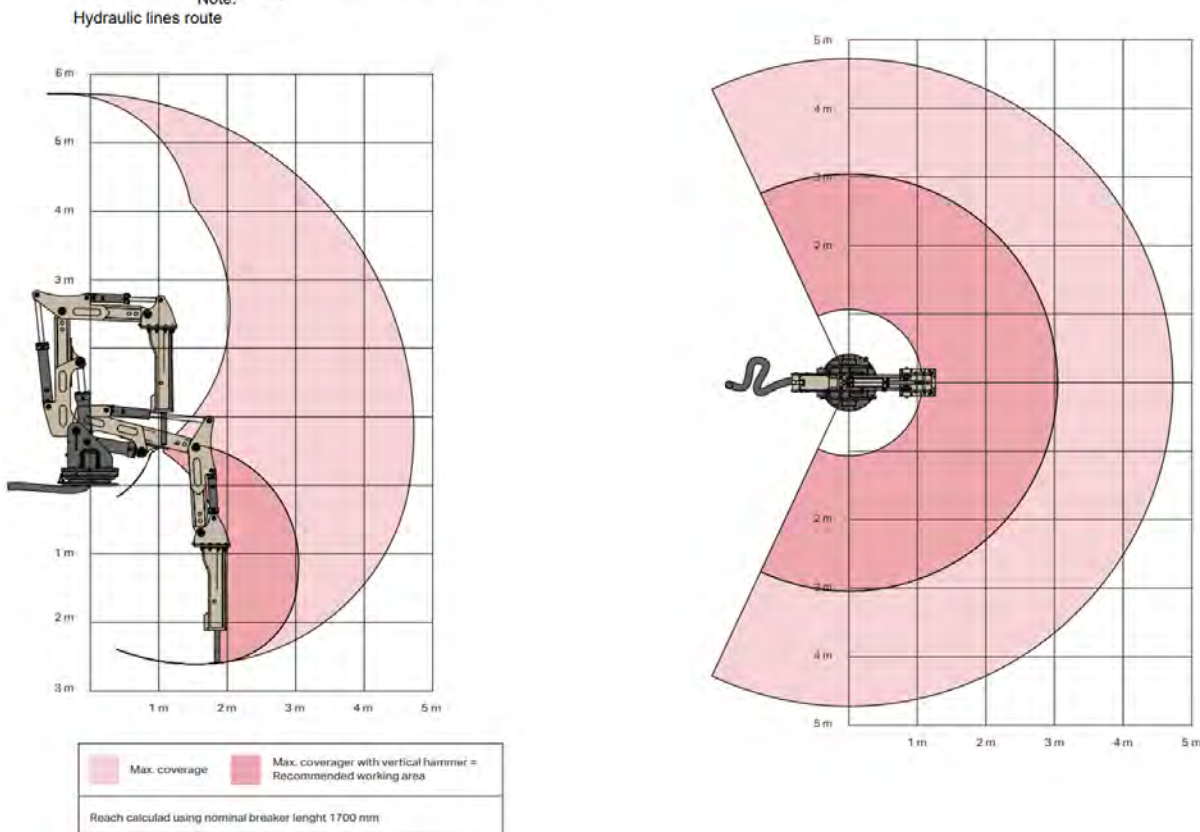
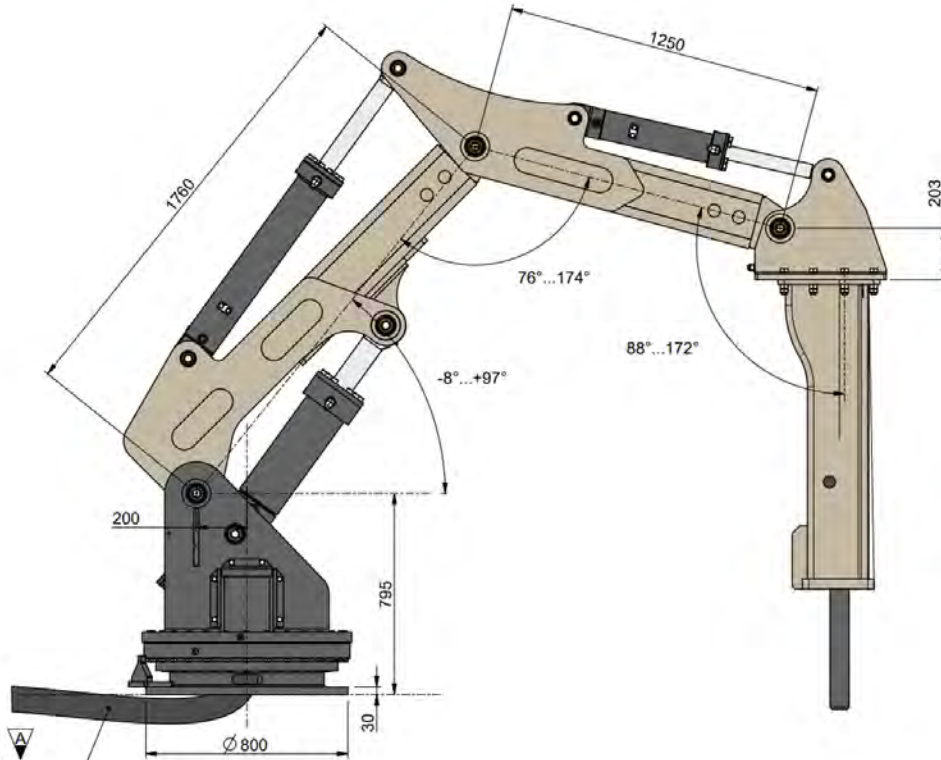

Normet reserves the right to change this specification without further notice

Pictures may include options and additional equipment.

SIDE VIEW & REACH AREA X24-420R

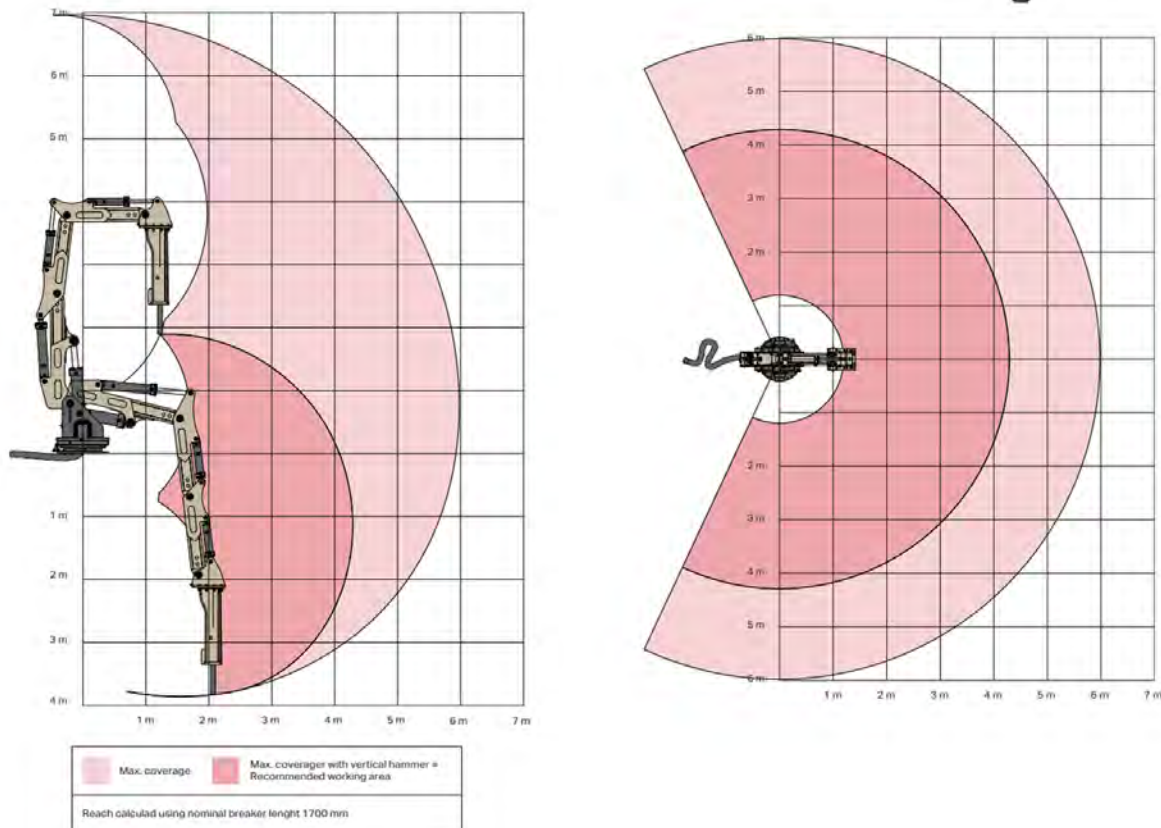
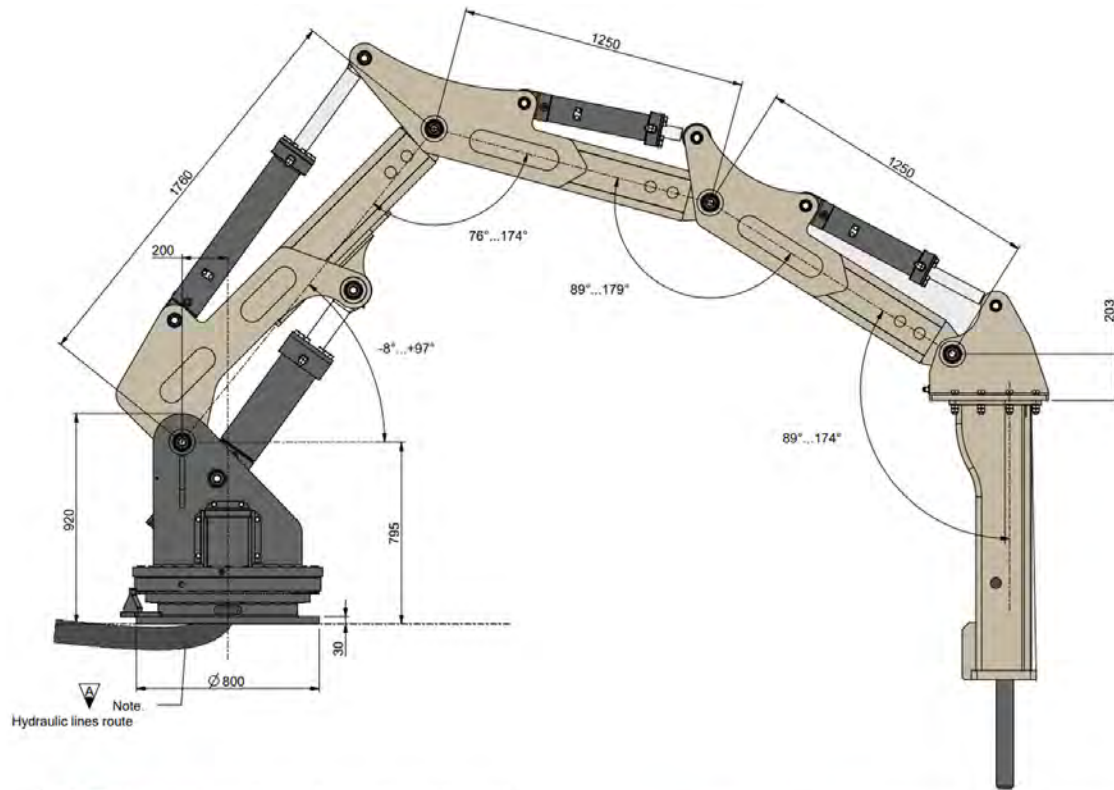

Normet reserves the right to change this specification without further notice

Pictures may include options and additional equipment.

SIDE VIEW POWER UNIT

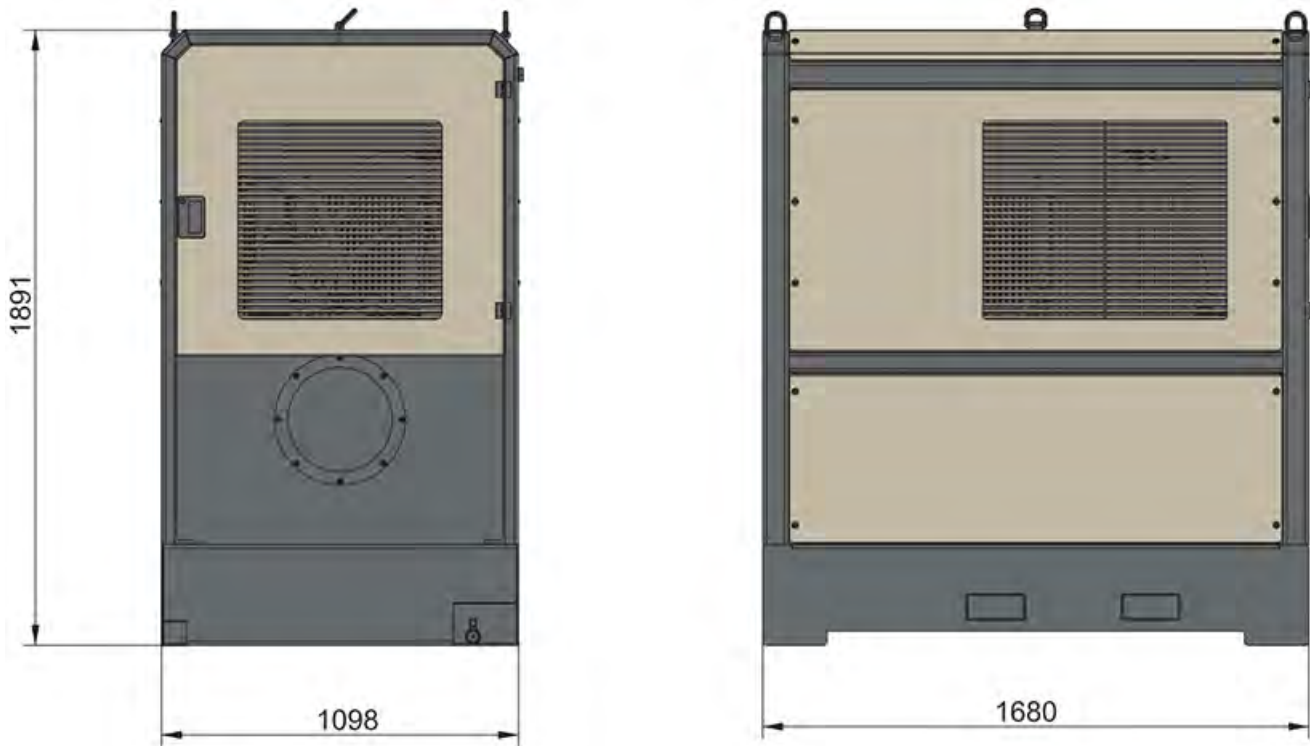

TOP VIEW POWER UNIT

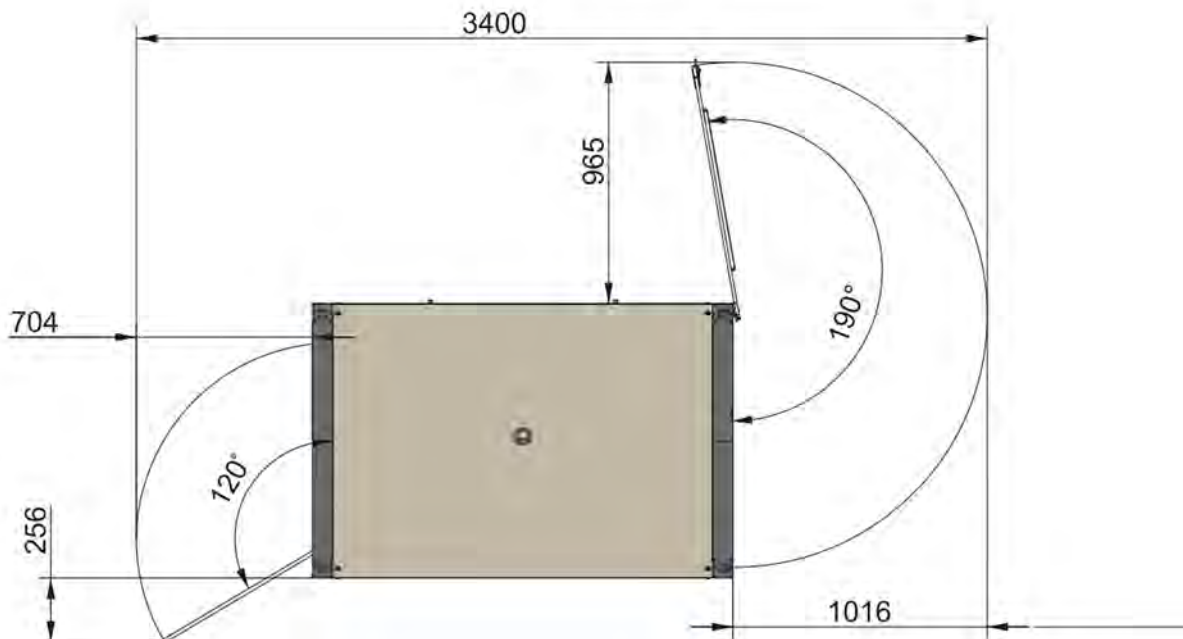

Normet reserves the right to change this specification without further notice

Pictures may include options and additional equipment.

BOTTOM VIEW POWER UNIT

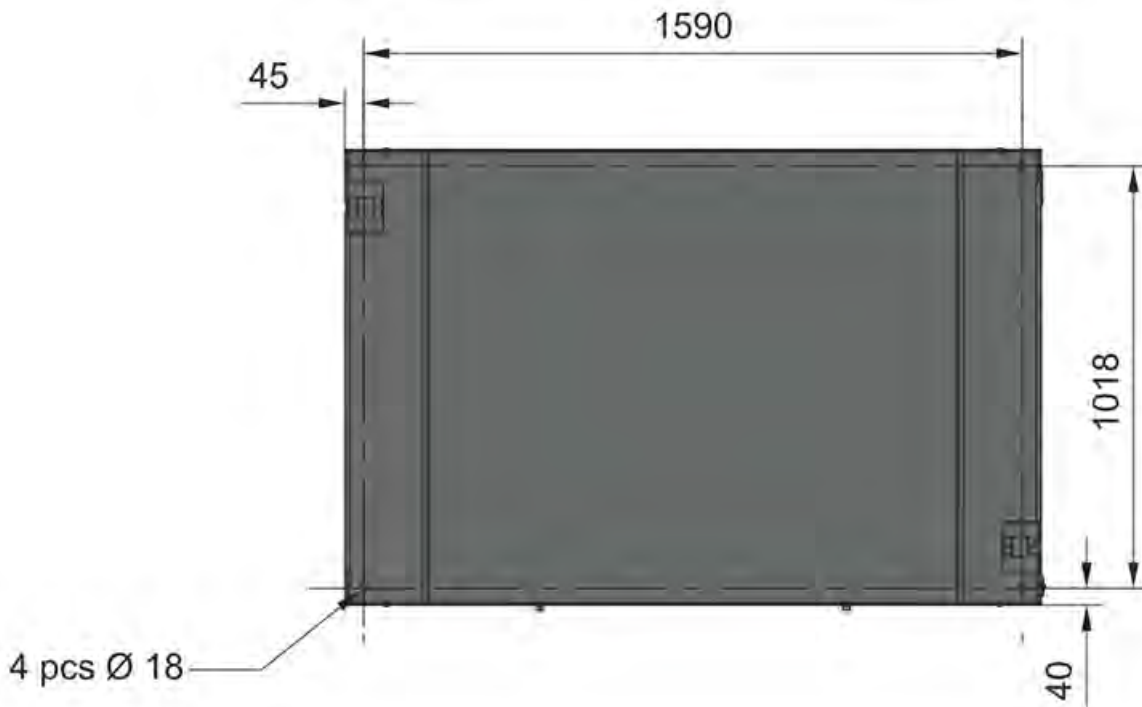

OPERATING WEIGHT (WITHOUT BREAKER)

Base machine X24-290R	1450 kg
Base machine X24-420R	1700 kg
Power units(without oil):	
Base machine PU18-43	800 kg
Base machine PU30-63	900 kg
Base machine PU37-87	950 kg
Base machine PU45-121	1200 kg
Base machine PU55-151	1310 kg

final machine weight variate in agree with selected options

SERVICES

NORMET SERVICES

Our services cover the whole life cycle of your equipment. They include start-up and commissioning, genuine spare parts, upgrades & modifications, and remanufacturing, as well as field service. We also offer improvement services such as operator training and process audits.

SPARE PARTS

Genuine parts from Normet Services ensure that you always have the highest quality parts available to keep your equipment up and running. Depending on your needs, we can offer everything from individual parts to complete parts contracts, and our professionals around the world have the experience to ensure that you have the parts you need when you need them.

Initial spare part packages:

Normet Xrock products have service kits available for commissioning, 2-year and 4-year operation and most critical parts.

UPGRADES AND MODIFICATIONS

Our Upgrades and Modifications services are designed to ensure the economical, efficient and purposeful performance of

your equipment over its entire life cycle. A service provided by a reliable OEM like Normet ensures the safety and performance of your equipment. Normet Upgrades and Modifications save you both time and money, while delivering the high quality you expect from us.

SERVICE CONTRACTS

With a service agreement, Normet manages your fleet with guaranteed availability and agreed costs, giving you transparency for your life cycle costs, annual operational budget and fleet uptime. This lets you focus on your core operations. Each service agreement is built and customized to meet the individual customer's needs from our portfolio of services. Depending on the level of service agreement you need, you can choose anything from basic technical support for an individual machine all the way up to services for your entire fleet, as well as process performance. The service levels we offer are:

- Parts Availability
- Fleet Support
- Fleet Availability
- Process Performance

The content of a service level can be tailored to meet your particular requirements.

TRAINING SERVICE

Our Training Services are available for you and your operators throughout the equipment lifecycle and they include:

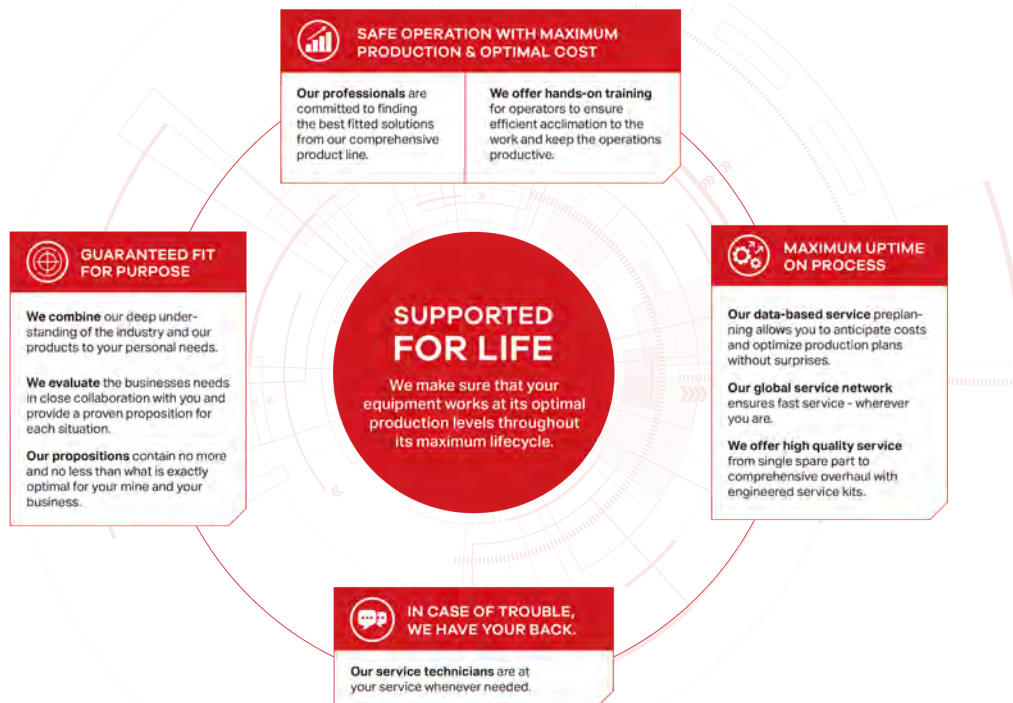

START-UP AND COMMISSIONING

1. OPERATOR TRAINING

	Start-up training	Commissioning
1.1 Classroom training		
General introduction and operation of machine	Basic	No classroom training included in commissioning
Safety instructions	Basic	
Use of manuals	Basic	
Technical introduction of equipment	Basic	
Hands-on service and pre-operation checks	Basic	
Controls and driving (starting, driving, stopping, parking)	Basic	
1.2 Practical training		
Pre-operation checks	Basic	Introduction
Driving, starting, stopping, parking	Basic	Introduction
Preparing the machine for specific operation conditions	Basic	Not covered
Operation	Basic	Introduction
Washing the machine	Basic	Introduction
Troubleshooting	Basic	Basic

2. MAINTENANCE AND REPAIR TRAINING

General operation of machines	Basic	Introduction
Symbols of drawings and codes	Basic	Not covered
Understanding hydraulic and electric schematics	Basic	Introduction
Control systems	Basic	Introduction
Function of main components (depending on equipment)	Basic	Introduction
Locations of components in the machine	Basic	Not covered
Periodical maintenance	Basic	Introduction
Troubleshooting	Basic	Not covered
Use of manuals	Basic	Introduction
Connection of hydraulic and electrical equipment	Basic	Not covered