



Charmec MF 605 V Long End SD



Normet reserves the right to change
this specification without further notice

Pictures may include options and additional equipment.

INTRODUCTION

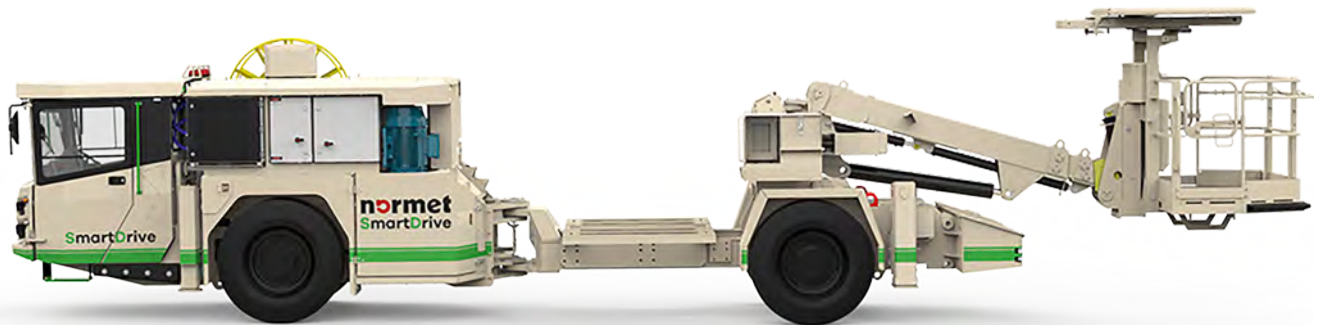

Charmec MF 605 V Long End SD is a fully electric carrier for external emulsion unit which is designed for easiness of use and high productivity. It uses the latest Li-ion battery technology and charges the batteries from the same AC-socket which is used to power the process. Charmec MF 605 V Long End SD is designed for face and production charging in underground mines and tunnels up to 65 m³ cross sections where max face height is 8,8 m.

The room for external emulsion kit is in the middle of the unit. Dedicated places for primers and detonators make it possible to bring all the needed materials to the workplace at once which eliminates the need for an additional explosive service vehicle. In addition, optional compressor eliminates the need for external pressure airline.

The fully electric vehicle architecture (SmartDrive) includes latest Li-ion battery technology, fast charging capability, and two high-torque direct drive electric motors, which provide instant torque and efficient operation without any local emissions. Energy recuperation technology comes as a standard feature. Batteries are charged during downhill driving and deceleration which further increases total efficiency of the operation.

Maximum speed is 20 km/h. The fully reversible 4WD with high traction capability and instant torque ensures safe and sure movement in difficult ground conditions. Majority of the braking is done via electric motors recuperating energy, but the vehicle also includes efficient hydraulic dual-circuit oil immersed multi-disc brakes to provide additional braking power when it is needed.

Vehicle has a front axle suspension system, which improves safety, driving comfort and increases component lifetime.

Normet's FOPS and ROPS approved safety cabin provides superior visibility and comfortable compartment for the driver and the passenger. Cabin controls are easy and ergonomic to use, and the multifunctional display (MID) provides driving information (speed, RPM, temperatures, safety warnings & alarms etc.), which can be recorded for further analysis. The enclosed cabin and SmartDrive provide low noise level.



NorSmart 3 electric system is designed for harsh underground environment. System consists of self-extinguishing wire harnesses with tinned wires, water tight conduits and all exposed components are minimum IP65 protection class. In addition, vehicle layout allows easy access to all service points, all daily checks can be done from the ground level.

TECHNICAL SPECIFICATION

CHARGING SYSTEM

Process platform on rear end of unit

Inner dimensions 1680 x 2020 x 1600 mm

Max. load 6000 kg

Center of gravity shown in the dimensional picture

Detonator box lining:

- Antistatic rubber lining
- IME SLP 22 lining

NBB3S BASKET BOOM

2-operator basket

Lifting capacity (without optional equipment) 500 kg

Max. lifting height and wall coverage specified in dimensional drawing

Automatic levelling of basket

Start/stop from basket

Battery operated emergency lowering system

Basket installation position:

- Regular
- Hanging (reduce max. lifting height 500 mm)

Basket:

- Standard 2-operator basket
- Front gate 2-operator basket
- Short 2-operator square tube basket
- Short 2-operator open profile basket

Person lifter safety system:

- Dangerous movement preventing system (mandatory in NAP, NAS, CE area)
- Dangerous movement warning system with overload monitoring
- Dangerous movement warning system without overload monitoring

ELECTRICAL SYSTEM

Main supply voltage

Power supply for the electrical functions

- 50 Hz
 - 380 V (IEC)
 - 400 V (IEC)
 - 415 V (IEC)
 - 525 V (IEC)
 - 690 V (IEC)
 - 1000 V (IEC)
 - 1000 V (AS/NZS)
- 60 Hz
 - 440 V (UL/CSA)
 - 440 V (IEC)
 - 480 V, (460 V) (UL/CSA)
 - 600 V, (575 V) (UL/CSA)
 - 1000 V (UL/CSA)

Robust and abrasion-resistant mains voltage supply cable with PUR outer sheath (excluding plug)

Hydraulically driven cable reel with spooling device

- No cable
- 100 m cable

Cable in / out reeling function from the cabin and near the reel

- With supply cable (excluding plug)
- Without supply cable (must be sourced and installed locally)

Pilot circuit

- No
- Yes

ELECTRIC MOTORS

Two direct drive permanent magnet electric motors

4-wheel drive, no separate transmission

Combined power rating 200 kW

PERFORMANCE

Max. tractive effort 99 kN

Tramming speed (horizontal) 20 km/h

Lateral gradient for tramming (continuous) 4°

Longitudinal gradient for tramming (continuous) 9°

Lateral gradient for operation 3°

BATTERY

Li-ion battery technology	
Nominal voltage	663 V
Energy content	90 kWh
Liquid cooled	
Fast charging capability	

BATTERY CHARGING

25-30 kW on-board 3-phase AC charging system
 for up to 2.5 hours of charging time (from 0 to 80%)

CCS type 2 fast-charging socket

to charge batteries from 0-80% in up to 40 min
 depending on charger

NOTE: compatible CCS charging station required
 with type 2 plug

AXLES AND BRAKES

Dana planetary type axles

Fixed load end axle

Suspended engine end axle

Electronic braking: energy recuperation
 via electric motor braking

Service brake: hydraulically powered dual-circuit oil immersed
 multidisc brakes in both axles

Safety/Parking brake: spring applied hydraulically released
 fail-safe -type brake

Brake testing possible from cabin

TYRES AND RIMS

Tyres:

- Nokian Tyres 12.00–20"
- Bridgestone 12.00–20"

Rims:

- Standard rims
- NDT inspected rims

STEERING

Orbitrol type hydraulic frame steering

Frame articulation +/- 42°

HYDRAULIC SYSTEM

Hydraulic oil tank capacity 145 l

Battery driven hydraulic system

Variable displacement pump system for carrier and
 explosive charging unit:

200 bar, 100 l/min

Electrically driven hydraulic system 50/60 Hz

Variable displacement pump system for carrier and
 explosive charging unit:

210 bar, 105/125 l/min at 1500/1800 rpm

24 VDC ELECTRICAL SYSTEM

2 x 12 V deep cycle batteries

24 V battery charger (DC/DC converter)

LED driving and indicator lights

LED work lights on cabin

LED work lights in basket

LED side lights

Warning LED light:

Color

- Amber
- Blue
- Red
- Green (n/a with rotating light pattern)
- White (n/a with rotating light pattern)

Light pattern

- Strobe
- Rotating

DRIVER'S COMPARTMENT

Enclosed 2-operator cabin FOPS/ROPS approved

Air conditioning and heating

Driver's seat and seat belt:

- Air suspended T-back seat with 3-point seat belt
- Air suspended heavy duty seat with 3-point seat belt

Passenger's seat:

- T-back seat with 3-point seat belt
- Heavy duty seat with 3-point seat belt
- 2 seats with retractable lap seat belts

Cabin door interlock switches with safety brake application

MACHINE CONNECTIVITY

- Machine connectivity hardware (WLAN/3G/4G/LTE)
- Data lifetime license (Include connectivity hardware)
- Analytics lifetime license (Include connectivity hardware and data lifetime license)

TECHNICAL DOCUMENTATION

Standard documents:

Instruction manuals, hard copy 2 pcs:

- English
- Russian
- One of destination EU languages

Spare parts manuals, hard copy 2 pcs:

- English
- Russian

PDF manuals on USB-stick 2 pcs, includes instruction and spare parts manuals

Additional documentation:

- Extra hard copies of manuals
- Extra PDF manuals
- LinkOne WebView electronic manuals
- Other than standard language manuals

OTHER

Dry chemical fire extinguisher system:

Ansul A-101, Checkfire 210

Powder extinguisher (2 pcs):

- 12 kg
- Ansul Sentry

Painting and taping:

- Standard painting and taping
- Painting and taping according to customer specification

Reversing camera:

- 3 cameras, 3 displays
- 3 cameras, 3 displays and reversing radar
- 6 cameras, 3 displays. OACR/VCR system recording device with 72 h memory (4 recorded cameras)
- 6 cameras, 3 displays. OACR/VCR system recording device with 72 h memory and reversing radar (4 recorded cameras)

2 pairs of support legs; extendable legs at the load end and standard at the engine end

Front and rear grounding straps:

- Flat cable
- Chain

Electric pump for brake release

Text labels in:

- En/Ru/One of destination EU languages
- Other language

Measurements:

- Noise
- Vibration

ACCESSORIES

PROCESS PRODUCTIVITY

- Installation service for external emulsion charging system
 - CE-marking for installation of external emulsion charging system
- Compressed air inlets with water separator on carrier
- Compressed air outlet and oil lubrication unit in basket
- Water inlet with filter and pressure regulator
- Electrically controlled face charging reel and valve with face charging hose 25 x 20 mm, 15 m
- Production charging
 - Direct hydraulic controlled hose pusher
 - Electrically controlled hose pusher and valve

Hose diameter and length (includes 4 pcs of groove pulleys)

- Without hose
 - 32 x 23 mm, 50 m
 - 40 x 31 mm, 50 m

Additional groove pulleys, 4 pcs

- 28 mm
- 32 mm
- 40 mm

Hose guides

- Hose guide for upward production charging
- Extension for hose upward hose pusher
- Diverting pulley for downward production charging

Charging hose reel material

- Steel
- Stainless steel

Production charging reel coupling size

- 1 ½" rotary coupling and tube
- 1" rotary coupling and tube

- Onboard compressor
 - 2.6 m³/min
 - 0.45 m³/min
- 230 l water tank above the cabin (increased machine height 200 mm)
- Hydraulically driven pressure washer with hose reel:

Water pressure, max. 180 bar

Water flow, max. 30 l/min

Hose length 20 m

- Standard pressure washer
- Stainless steel reel and rod
- Additional hydraulic pump system
- Socket supply voltage
 - 220/230/240 V (no UL/CSA or AS/NZS approval)
 - 110/120 V
- 3 x 100 W LED working lights on cabin roof (no UL or AS/NZS approval)

CARRIER PRODUCTIVITY

- Accessories for enclosed cabin:
 - Two-piece windscreen
 - Sliding rear window for driver's side
 - Audio system
 - Heated mirrors
 - 12 V, 20 A power supply in cabin with socket and connector
 - Deutch connector for 24 V, 10 A for external power supply
 - Drive battery coolant heater with interior heater and 24 VDC battery charger (230 V)
 - Fluid evacuation panel with sampling points
 - Automatic lubrication system
 - Spare rim and tyre
 - Toolbox and maintenance tools
 - Interior cooling fan
 - Wax tape for electric connectors

SAFETY BASKET BOOM

- Safety roof or bar on basket
 - Safety bar
 - Safety bar with hydraulic lift
Reduces lifting capacity 60 kg
 - Safety roof with hydraulic lift
Reduces lifting capacity 100 kg
 - Safety roof with hydraulic lift and slide
Reduces lifting capacity 200 kg

NOTE: safety roofs and bar for the basket boom affect to the lifting capacity.

Accessories for basket boom:

- Boom suspension
- LED working lights on safety roof/bar
- Operator present: Foot pedal switch on basket
- Operator present: Spring loaded valve levers
- 24 V fan in the basket

SAFETY

- Safety roof or bar on basket
 - Safety bar
 - Hydraulic liftable safety bar
Reduces lifting capacity 60 kg
 - Safety roof with hydraulic lift
Reduces lifting capacity 100 kg
 - Safety roof with hydraulic lift and slide
Reduces lifting capacity 200 kg

NOTE: safety roofs and bar for the basket boom affect to the lifting capacity.

Accessories for safety roof/bar:

- LED working lights on safety roof/bar (2 pcs)
- Boom suspension
- Cabin door puddle lights

- Extra warning LED light
 - Color
 - Amber
 - Blue
 - Red
 - Green (n/a with rotating light pattern)
 - White (n/a with rotating light pattern)
 - Light pattern
 - Strobe
 - Rotating
- Direction lights (left/right)
 - Green / Red
 - Red / Green
- Extra warning LED light with battery backup
 - Color
 - Amber
 - Blue
 - Red
 - Green (n/a with rotating light pattern)
 - White (n/a with rotating light pattern)
 - Light pattern
 - Strobe
 - Rotating
- Seat belt interlock switch applies safety brake
- Redundant brake monitoring system
- Protection guards for tunnel curtains
- Methane monitoring system
- Tyre pressure indicators
- Warning triangles
- Flashlight with charger
- Hearing protectors
- Wheel chocks with brackets

BEV SAFETY FEATURES

- Battery safe box (for transportation and storage)

SERVICES

NORMET SERVICES

Our services cover the whole life cycle of your equipment. They include start-up and commissioning, genuine spare parts, upgrades & modifications, and remanufacturing, as well as rental and leasing offerings, and field services. We also offer improvement services such as operator training and process audits.

SPARE PARTS

Genuine parts from Normet Services ensure that you always have the highest quality parts available to keep your equipment up and running. Depending on your needs, we can offer everything from individual parts to complete parts contracts, and our professionals around the world have the experience to ensure that you have the parts you need when you need them.

Initial spare parts package:

Available for 1000h of use*. Includes periodical service, most common wearing parts and most critical safety parts.

Spare parts packages made for customer needs:

Available based on hours of use*. Includes periodical service, most common wearing parts and most critical safety parts.

* Recommendations are based on average hours – can vary a lot depending on work site conditions.

UPGRADES AND MODIFICATIONS

Our Upgrades and Modifications services are designed to ensure the economical, efficient and purposeful performance of your equipment over its entire life cycle. A service provided by a reliable OEM like Normet ensures the safety and performance of your equipment. Normet Upgrades and Modifications save you both time and money, while delivering the high quality you expect from us.

SERVICE CONTRACTS

With a service agreement, Normet manages your fleet with guaranteed availability and agreed costs, giving you transparency for your life cycle costs, annual operational budget and fleet uptime. This lets you focus on your core operations. Each service agreement is built and customized to meet the individual customer's needs from our portfolio of services. Depending on the level of service agreement you need, you can choose anything from basic technical support for an individual machine all the way up to services for your entire fleet, as well as process performance. The service levels we offer are:

- Parts Availability
- Fleet Support
- Fleet Availability
- Process Performance

The content of a service level can be tailored to meet your particular requirements.

TRAINING SERVICE

Our Training Services are available for you and your operators throughout the equipment lifecycle and they include:

	 Operation & Maintenance	 Spraying	 Charging	 Scaling
ADVANCED	Advanced fault diagnostics & troubleshooting	Concrete chemicals, testing and preparing for EFNARC-certificate test		
INTERMEDIATE	Troubleshooting training Foundations of electrics, hydraulics and mechanics NorSmart	Advanced training in concrete spraying Economics of concrete spraying	Advanced training in explosives Economics of charging	Advanced training in scaling Economics of scaling
BASIC	Operation and Maintenance Training Basic Product Training	Basic understanding of concrete spraying	Basic understanding of charging	Basic understanding of scaling
LEVEL	SERVICE	PROCESS KNOWLEDGE		

START-UP AND COMMISSIONING

1. OPERATOR TRAINING

	Start-up training	Commissioning
1.1 Classroom training		
General introduction and operation of machine	Basic	No classroom training included in commissioning
Safety instructions	Basic	
Use of manuals	Basic	
Technical introduction of equipment	Basic	
Hands-on service and pre-operation checks	Basic	
Controls and driving (starting, driving, stopping, parking)	Basic	
1.2 Practical training		
Pre-operation checks	Basic	Introduction
Driving, starting, stopping, parking	Basic	Introduction
Preparing the machine for specific operation conditions	Basic	Not covered
Operation	Basic	Introduction
Washing the machine	Basic	Introduction
Troubleshooting	Basic	Basic

2. MAINTENANCE AND REPAIR TRAINING

General operation of machines	Basic	Introduction
Symbols of drawings and codes	Basic	Not covered
Understanding hydraulic and electric schematics	Basic	Introduction
Control systems	Basic	Introduction
Function of main components (depending on equipment)	Basic	Introduction
Locations of components in the machine	Basic	Not covered
Periodical maintenance	Basic	Introduction
Troubleshooting	Basic	Not covered
Use of manuals	Basic	Introduction
Connection of hydraulic and electrical equipment	Basic	Not covered

DIMENSIONS

	SE	LE		SE	LE
Length	10 910 mm	11 710 mm	Ground clearance	370 mm	370 mm
Width	2000 mm	2000 mm	Turning radius outer	7820 mm	8750 mm
Height	2360 mm	2360 mm	Turning radius (with boom turned 10°)	7200 mm	8080 mm
Wheel base	3650 mm	4450 mm	Turning radius inner	4480 mm	5610 mm
Track	1670 mm	1670 mm			

SIDE VIEW – BASIC MACHINE

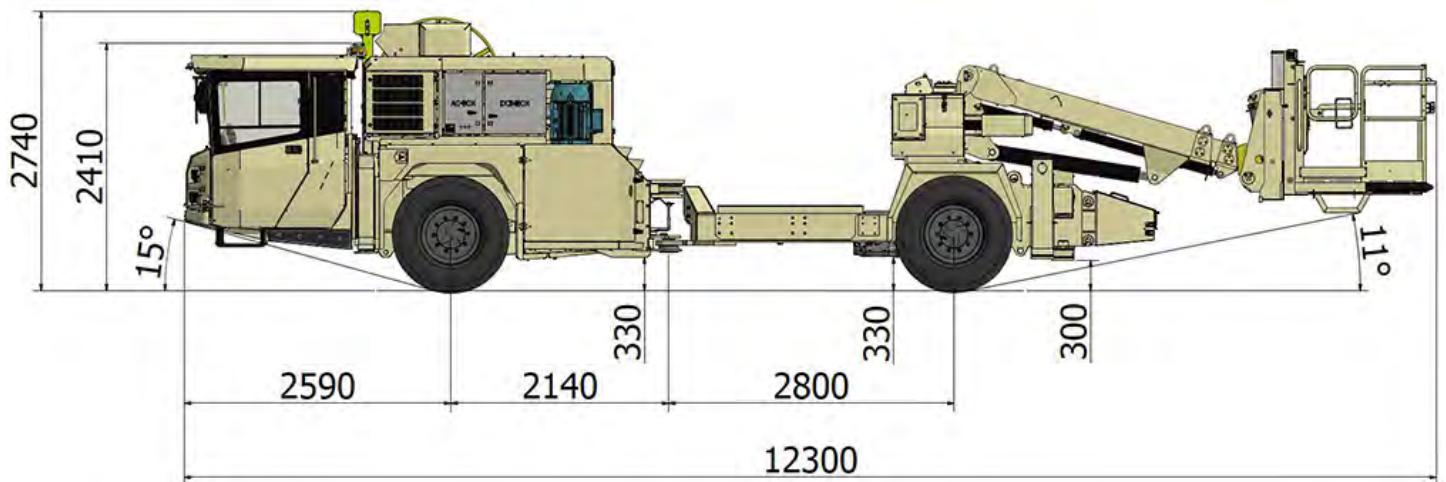

SIDE VIEW – MACHINE WITH OPTIONS

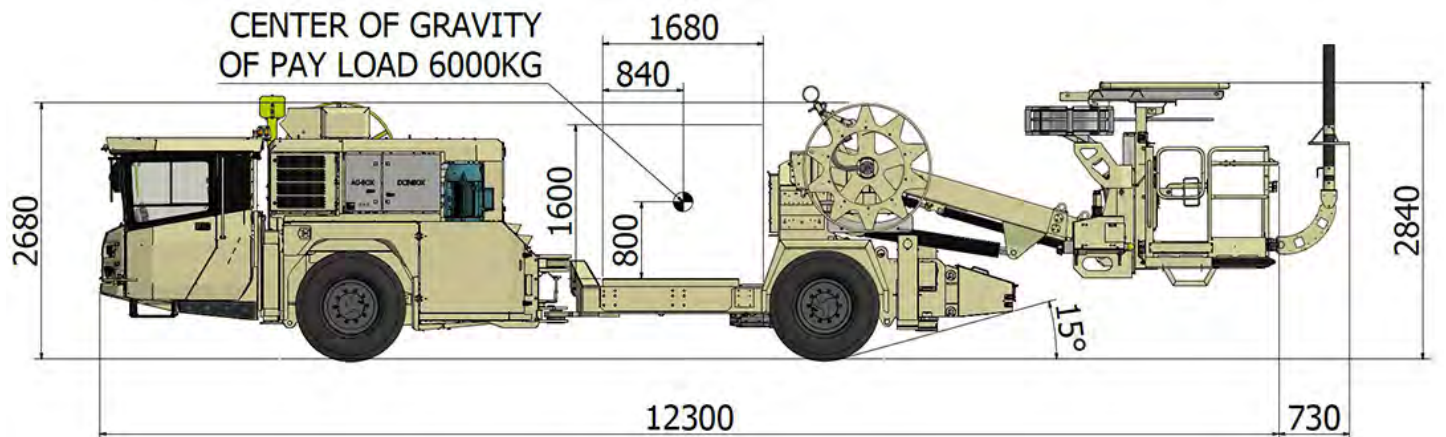

Normet reserves the right to change this specification without further notice

Pictures may include options and additional equipment.

TOP VIEW

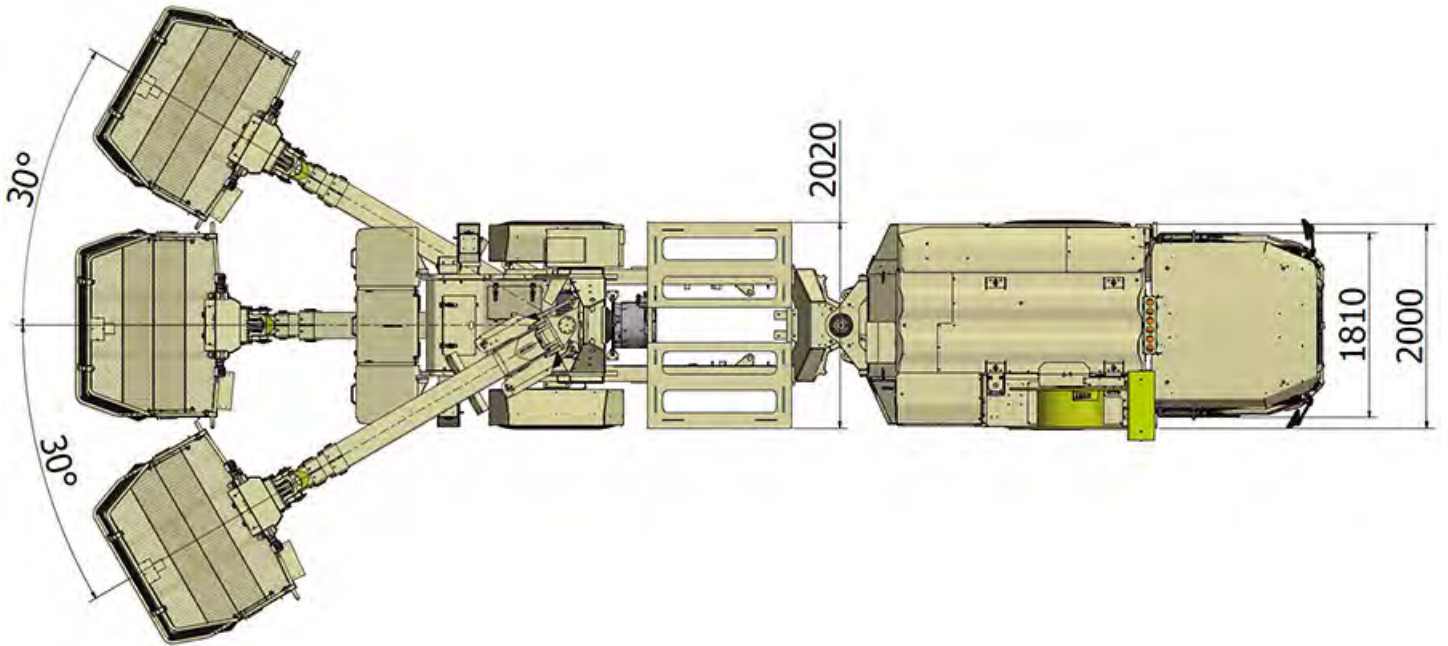

Normet reserves the right to change this specification without further notice

Pictures may include options and additional equipment.

TURNING RADIUS

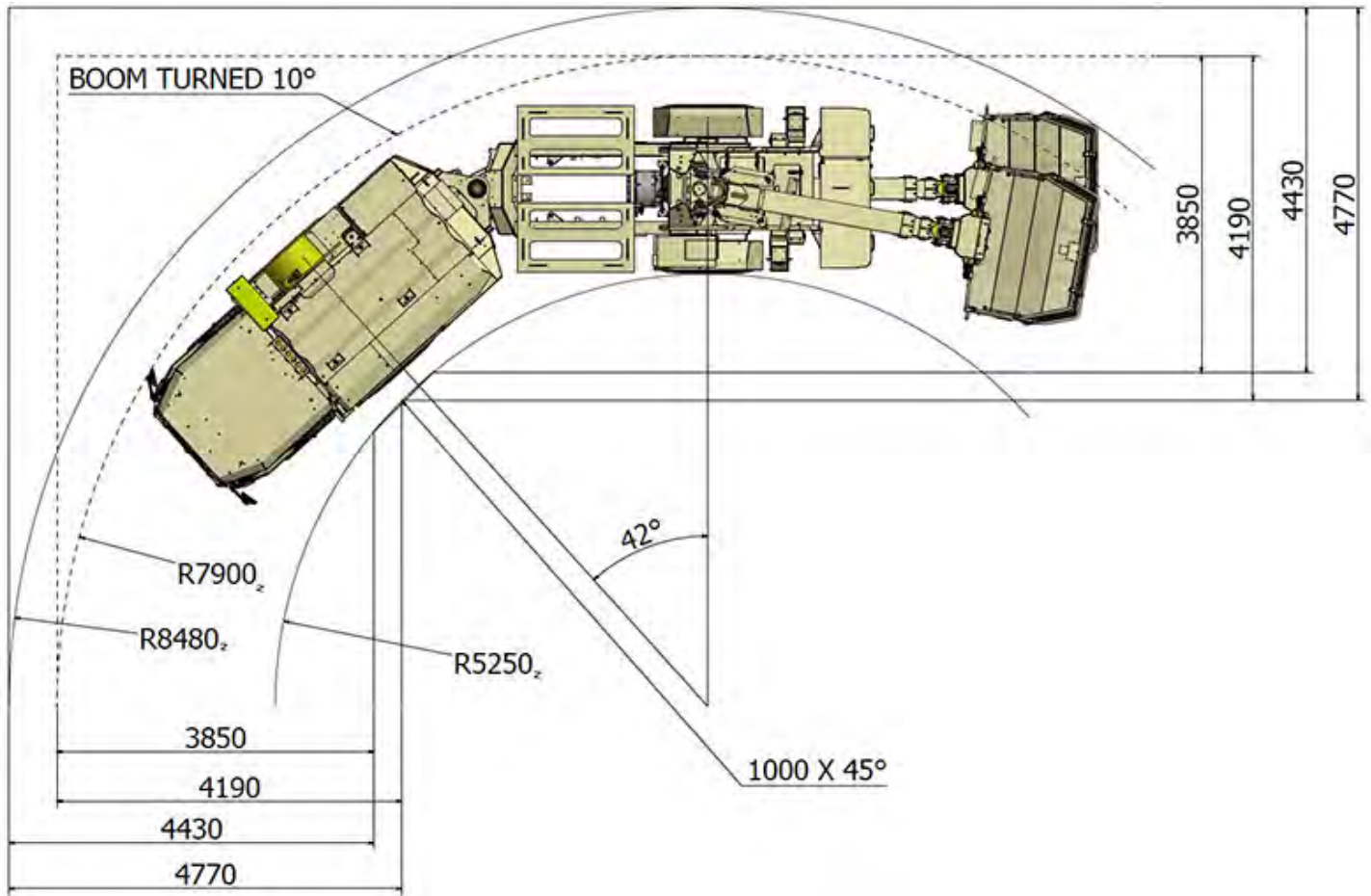

Normet reserves the right to change this specification without further notice

Pictures may include options and additional equipment.

FRONT AND BACK VIEWS

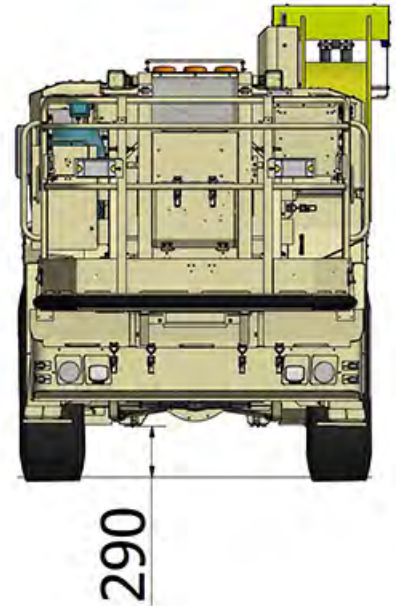

BOOM REACH

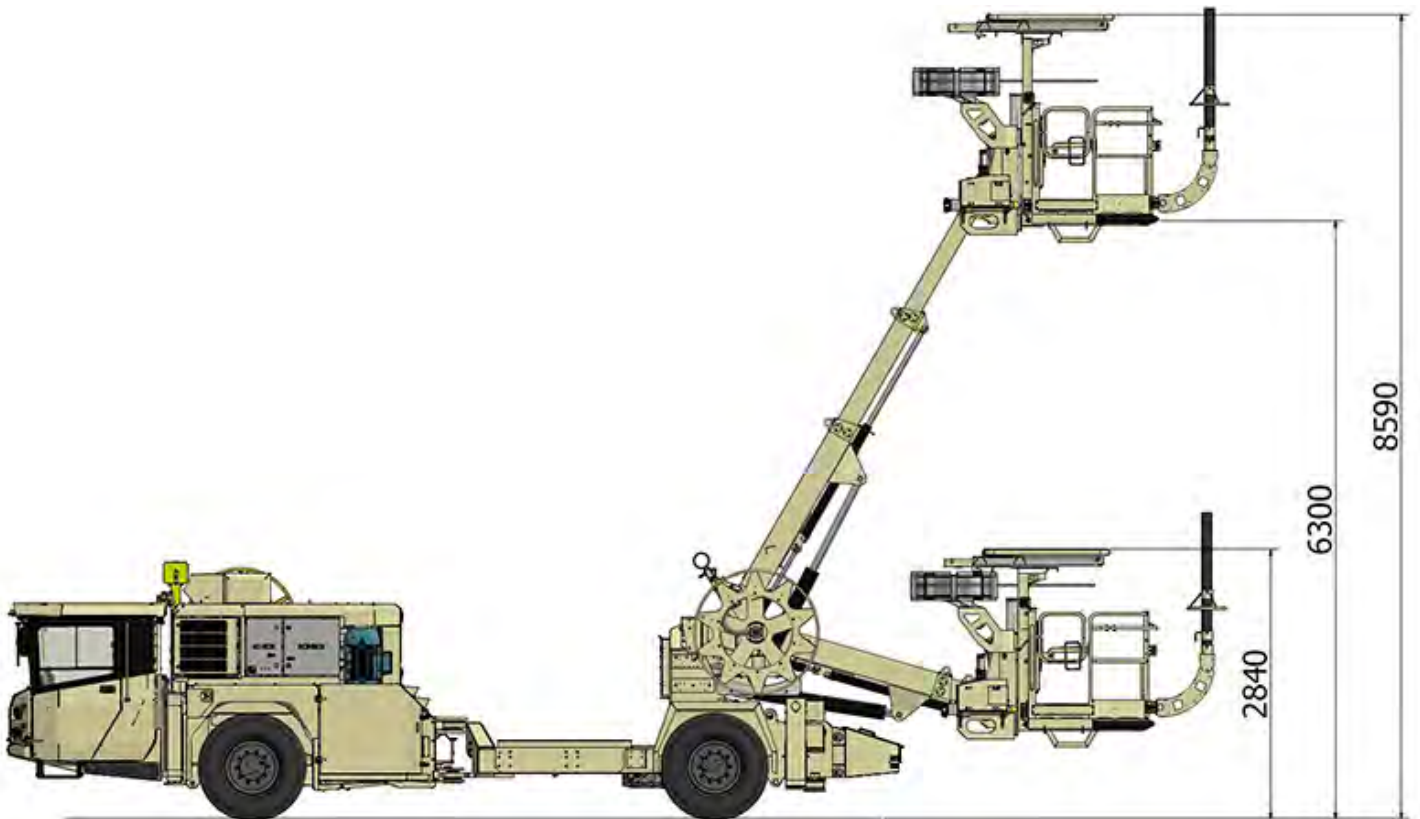

Normet reserves the right to change this specification without further notice

Pictures may include options and additional equipment.

BOOM REACH - NBB3S WITH 30° TURN

Maximized face coverage with single position of machine

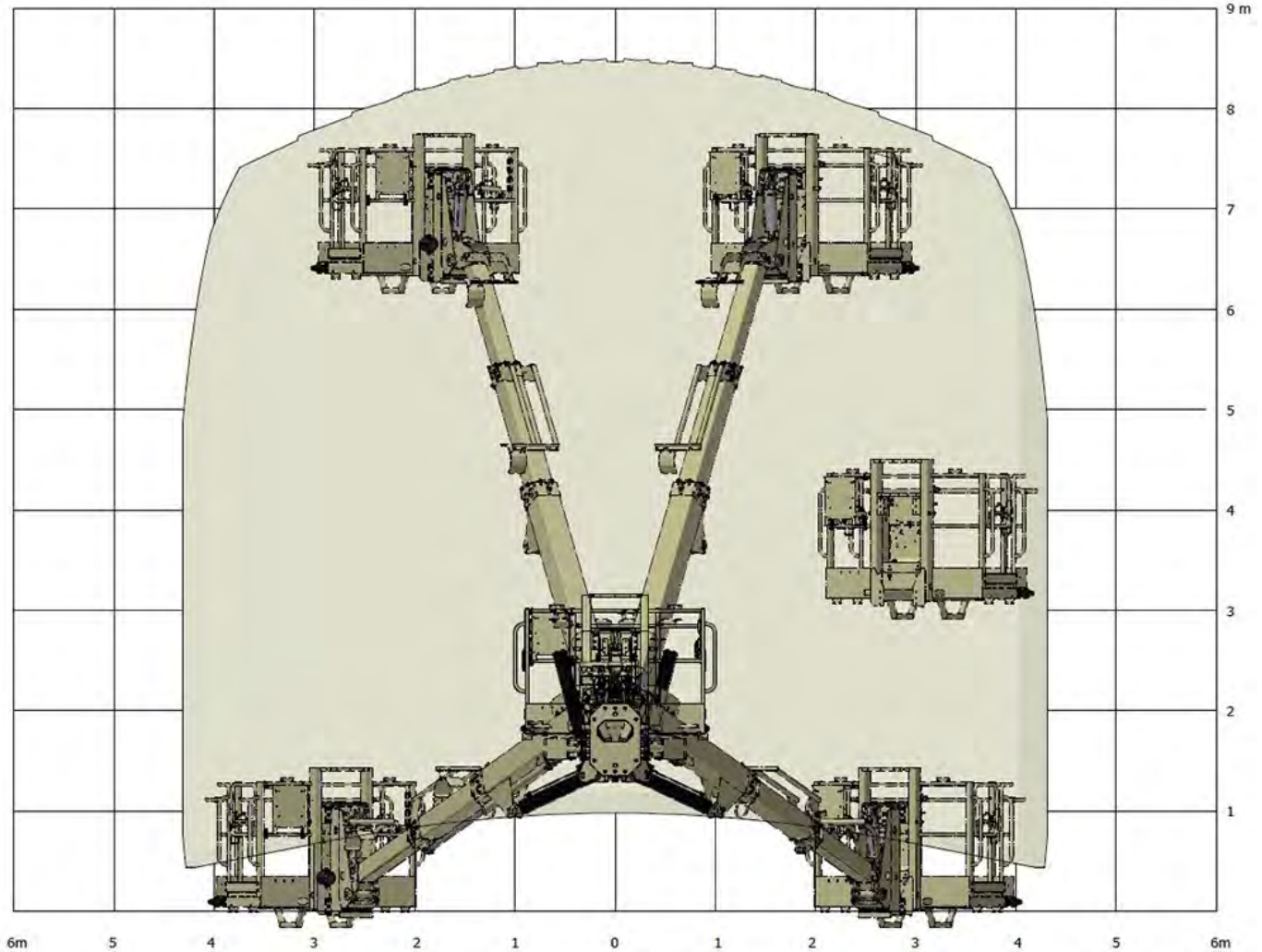

Normet reserves the right to change this specification without further notice

Pictures may include options and additional equipment.

BOOM REACH - NBB3S WITH 30° TURN

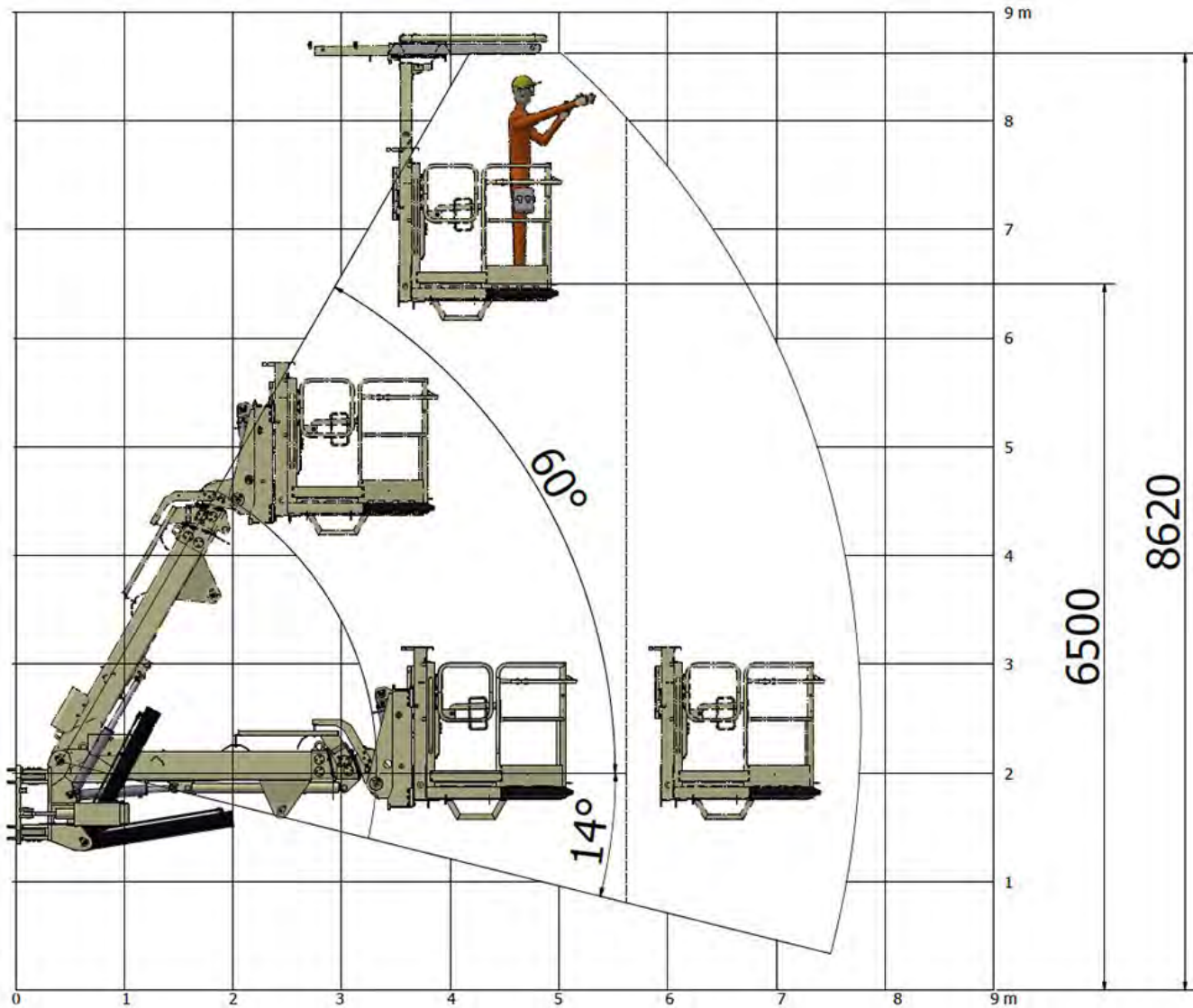

Normet reserves the right to change this specification without further notice

Pictures may include options and additional equipment.

DRIVING RANGE AND TRACTIVE EFFORT

DRIVING RANGE

Driving range curve: DOC060017

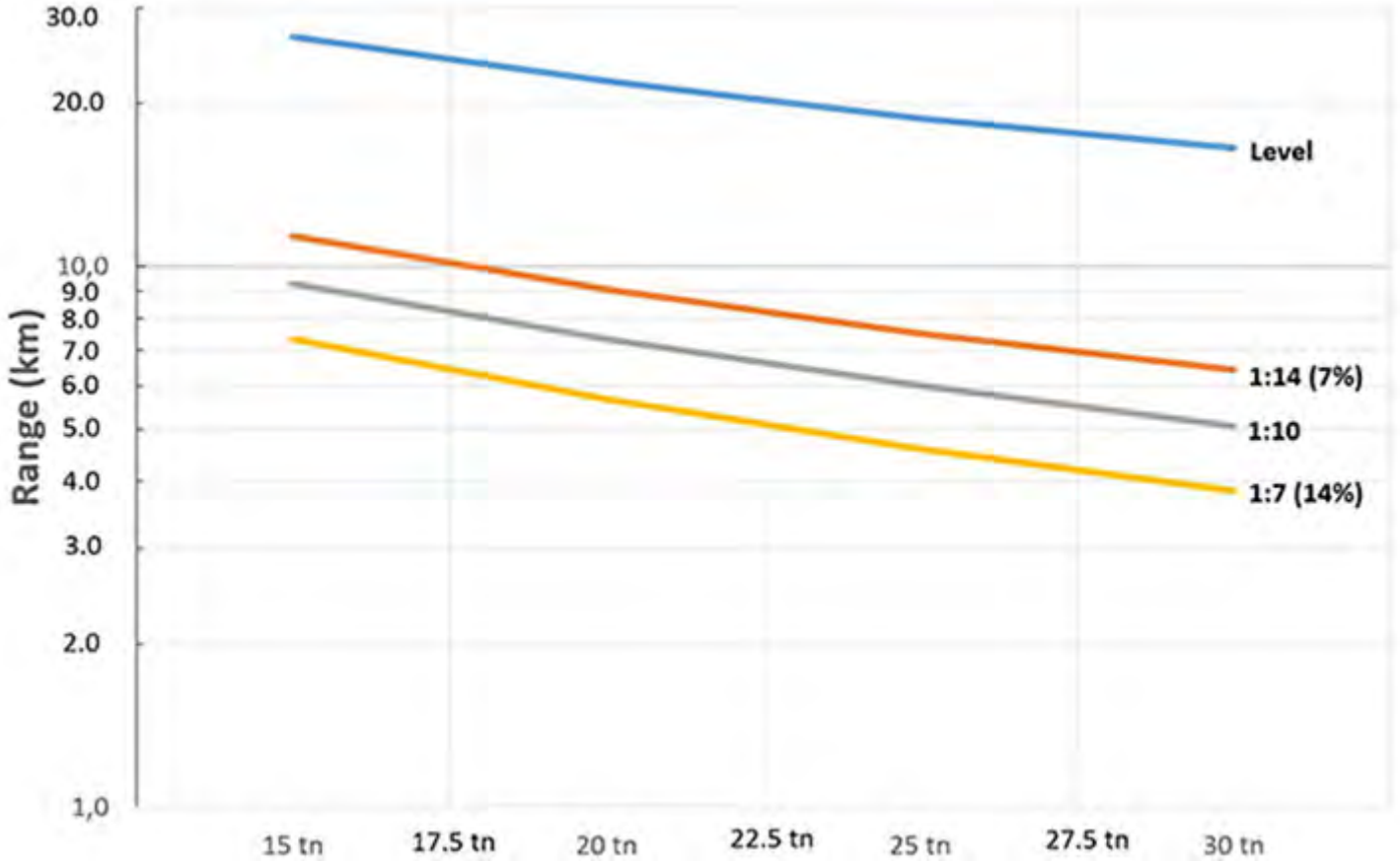

OPERATING WEIGHT

Empty	19 000 kg
Fully loaded	25 000 kg

TRACTIVE EFFORT

Performance curve: DOC059935

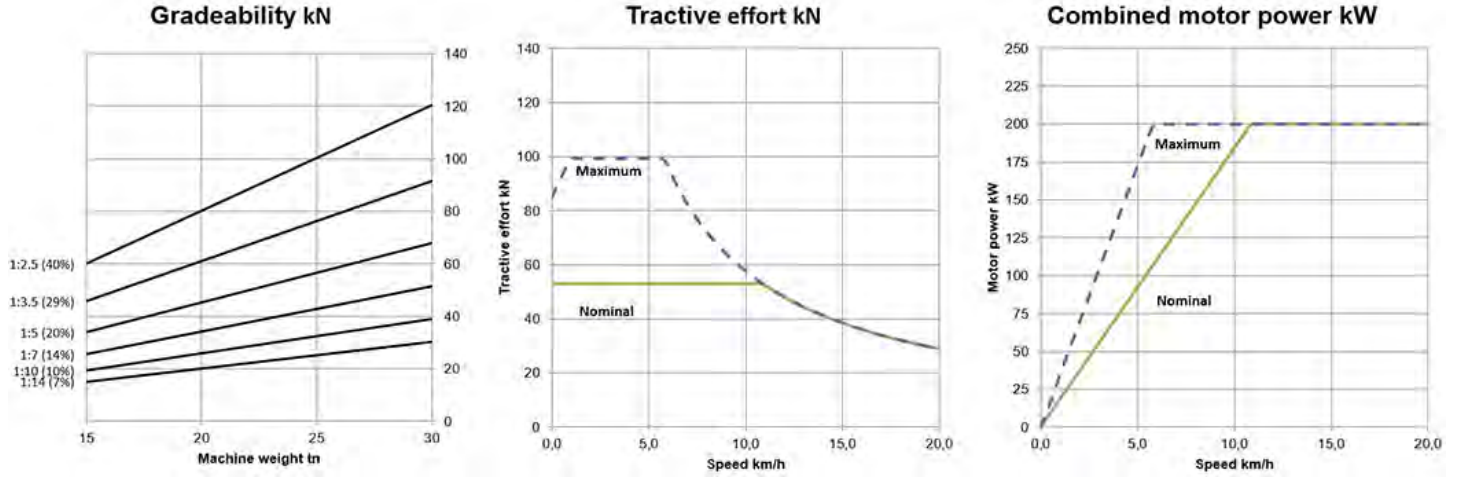

Normet reserves the right to change this specification without further notice

Pictures may include options and additional equipment.