

Edge Compact

TW1520

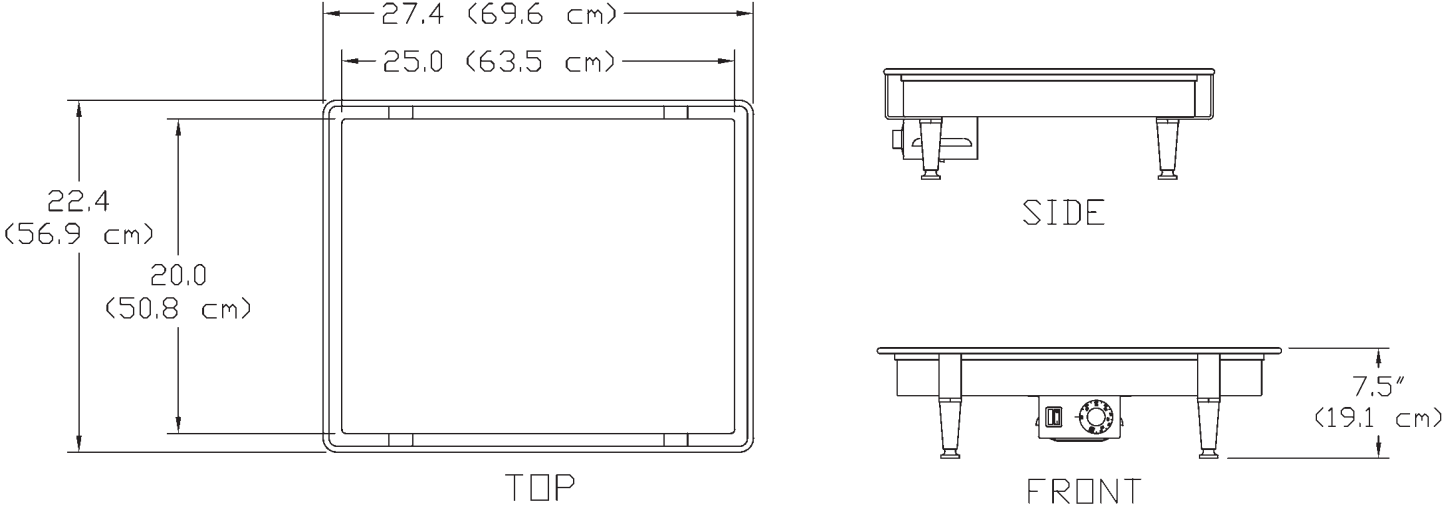

Equipment Details

Temperature Control	Yes	Shipping Weight	49lbs/22kg
Maximum Heat	425F/218C	Machine Weight	39lbs/17kg
Programmable Timer	No	Voltage	120
Power Cord Length	72"	Wattage	1750
Power Plug	NEMA 5-20P	Amps	14.6/7.6



PROLUXE™

CORPORATE HEADQUARTERS
20281 HARVILL AVE. PERRIS, CA 92570

HELPING COMMERCIAL KITCHENS
PRODUCE GREAT FOOD FASTER

ADVICE AND SUPPORT
1-800-624-6717

High Production for Compact Spaces

Easily heat, warm, and cook fresh flour and corn tortillas where counter space is limited. With a 15" x 20" grilling surface and patented cast-in heating elements, you'll have even heat distribution throughout, even during peak rush hours. Backed with a limited lifetime warranty on the heating element.

Edge Compact

15"x20" Flat Tortilla Grill
TW1520



Fresh And Consistent

Easily add fresh tortillas to your menu and gain the advantage over the competition. Fits up to 2 large tortillas or 4 small tortillas.



PATENTED EMBEDDED HEATING ELEMENT
LIMITED LIFETIME WARRANTY



EVEN HEAT DISTRIBUTION TECHNOLOGY



HIGH PRODUCTION



COMPACT SIZE