



BEACONS

 6410A
 Only

6410 SERIES

Low-Intensity Strobe

ECCO's low profile 6410 Series strobes are designed specifically for forklift and other material handling/industrial applications. The 6410 Series offers a cost-effective, high quality product that will operate consistently in a full range of 12-80V applications.

Models

PART NO.	VOLTAGE	AMPS	JOULES	FPM	MOUNT
6410A	12-80	0.3	1.5	70	3 Bolt
6410A-MG	12-24	0.3	1.5	70	Magnet

Features and Benefits

- Compact and economical low intensity strobe ideal for industrial applications
- Rugged glass filled nylon base and polycarbonate lens
- Field replaceable snap-fit flashtube
- Single flash operation (70 FPM)
- Reverse polarity, voltage spike and surge protected
- Temperature Range: -22°F to +122°F (-30°C to +50°C)
- Warranty: Strobe = 2 years, Flashtube = 6 months

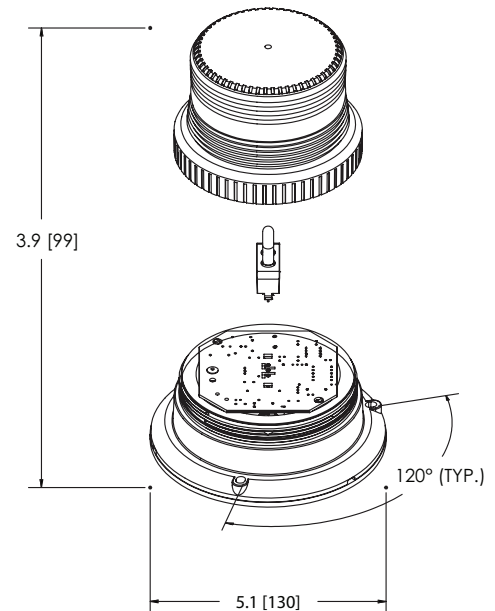

Parts & Accessories

- Flashtube 'U': R6410FT
- Lenses: Amber - R6400LA