



WORKLIGHTS



EW2011B

Blue Moving Arrow

ECCO's EW2011B Blue Moving Arrow is designed specifically for material handling applications to provide a visual warning for pedestrians in the vicinity of mobile equipment. This light is intended to supplement a 360° warning light by projecting a moving blue warning arrow onto the ground in the front or rear of the vehicle. This additional safety feature is especially useful where blind corners are present (i.e. warehouse racking) and is likely to be seen by pedestrians who are not looking up or paying close attention to their surroundings. Featuring 12-80 voltage operation, an aluminium housing, and polycarbonate lens, the EW2011B is extremely resistant to impact and vibration damage.

Models

PART NO.	VOLTAGE	LED COLOUR	AMPS
EW2011B	12-80	■	1.8

Design Features

- Nine 3-Watt LEDs
- Moving blue arrow projection
- Pedestrian warning for material handling applications
- Use on worksites near heavy pedestrian areas
- Aluminium heatsink housing
- Stainless steel mounting bracket
- Polycarbonate lens
- Temperature range: -40°C to +70°C (-40°F to +158°F)

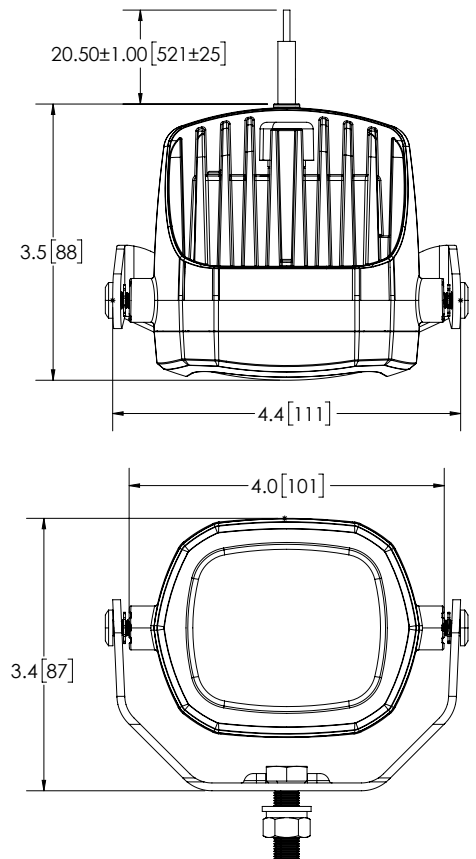

T: 1800 025 921 | E: esgapcs@esg.global