



BACK-UP ALARMS

600 SERIES

Designed to meet all the harsh operational requirements of any fleets equipment, ECCO 600 Series alarms feature a reverse-mounted speaker design and reinforced nylon housing providing unrivaled durability. These alarms are so robust that an ECCOLIFE™ warranty covering the alarm for the life of the vehicle is offered on all models. Smart Alarm® models measure ambient noise and adjust their sound level, creating a volume that is safe without being annoying or contributing to noise pollution. Smart Alarms eliminate the need for constant manual adjustment and help prevent intentional alarm disconnection.

Models

PART NO.	TYPE	VOLTAGE	dB(A)	AMPS	APPROVALS
SA901N	Smart	12-24	82-107	0.3	CE, R10, UL, IP64
SA931N	Smart	12-48	82-102	0.2	CE, R10, UL, IP64
610N	-	12-36	97	0.4	SAE Type C, CE, R10, UL, AMECA
630N	-	12-36	107	1.2	SAE Type B, CE, R10, UL, AMECA

Features and Benefits

- Reverse-mounted speaker enhances sound and protects the speaker from dust and moisture ingress
- Reinforced nylon housing eliminates corrosion damage
- Sealed in epoxy for protection against dust, moisture, and vibration
- Steam cleanable and pressure washable
- Works on positive or negative ground systems
- Temperature Range: -40°F to +185°F (-40°C to +85°C)

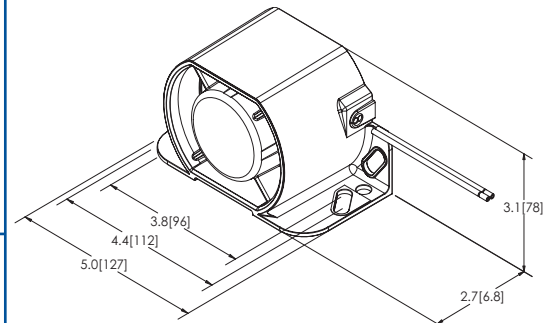

Alarm Specifications

Connection: 16 AWG blunt cut wires
 Reinforced nylon housing
 Recommended mounting bolt:
 5/16-18 UNC Grade 5
 Recommended washer:
 5/16" Type A, Series N or W
 Recommended mounting torque:
 156 in. lbs.