

## MINIBARS



### 5517 Reflex® SAE Class I LED, 17"

The 5517 Series 17" LED minibar is a compact and powerful warning solution with permanent, vacuum-magnet, and magnet mount options. This minibar, outfitted with 60 (single-colour) and 108 (dual-colour) high-intensity LEDs, provides full 360-degree lighting to attract the attention of drivers on the road. The 5517 Series 17" LED minibar features 37 single-colour and 97 dual-colour flash patterns, making it ideal for work trucks, snowplows, or any other vehicle applications. Models with vacuum-magnet mounts include a cigarette plug switch with on/off and flash pattern control.

#### Models

PART NO.	MOUNT	LENS COLOUR	LED COLOUR
5517A	4 Bolt or VM	<span style="color: orange;">■</span> A	<span style="color: orange;">■</span> A
5517CX	4 Bolt or VM	<span style="border: 1px solid black; display: inline-block; width: 10px; height: 10px;"></span> C	<span style="color: orange;">■</span> A <span style="border: 1px solid black; display: inline-block; width: 10px; height: 10px;"></span> C
5517CX	4 Bolt or VM	<span style="border: 1px solid black; display: inline-block; width: 10px; height: 10px;"></span> C	<span style="color: blue;">■</span> AB <span style="border: 1px solid black; display: inline-block; width: 10px; height: 10px;"></span> AC <span style="color: green;">■</span> AG <span style="color: red;">■</span> AR

Replace "X" with A = Amber, B = Blue, C = Clear, G = Green, R = Red  
Add "-VM" mounting extension to end of model for vacuum-magnet mount

#### Design Features

- 12-24 VDC, 6.2 Amps
- 60 LEDs (single-colour) or 108 LEDs (dual-colour)
- 37 flash patterns (single-colour) or 97 flash patterns (dual-colour)
- Cigarette plug with on/off and flash pattern selection switch (vacuum-magnet only)
- Sync-capable with most ECCO products including all directionals
- Temperature Range: -22°F to +122°F (-30°C to +50°C)

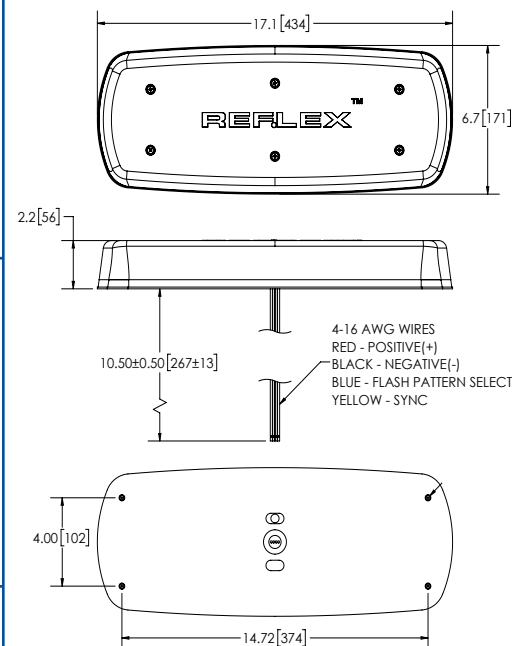

#### Accessories

- Mounting Feet: EZ5500BKT
- Vacuum-Magnet Mount: A5545VMK