

The Silver ECCOLED R65 Beacon utilises powerful LEDs, arranged to produce a 360° flash pattern with a flash rate of 125FPM for maximum visibility by combining the solid-state, maintenance free long-life nature of LED technology. This high-performance range has increased EMC, is robust and compact in a popular housing design and is available in four standard mounting options. The ECCOLED range of beacons are suitable for a variety of vehicles including applications where the UK lighting regulation Chapter 8 is a requirement\*. This range is designed to maximise resilience to excessive vibration, increase the life of the product and are backed by a three-year warranty.

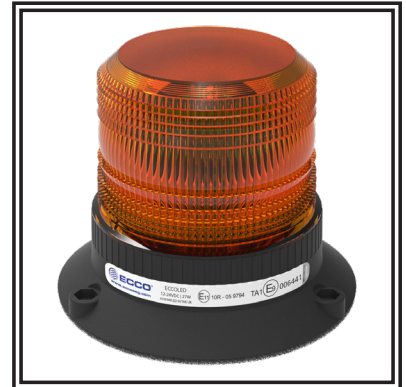

\* Amber version only.

**IMPORTANT!** Read all instructions before installing and using. Installer: This manual must be delivered to the end user.



### WARNING!

Failure to install or use this product according to manufacturers recommendations may result in property damage, serious injury, and/or death to those you are seeking to protect!



**Do not install and/or operate this safety product unless you have read and understand the safety information contained in this manual.**

1. Proper installation combined with operator training in the use, care, and maintenance of emergency warning devices are essential to ensure the safety of you and those you are seeking to protect.
2. Exercise caution when working with live electrical connections.
3. This product must be properly grounded. Inadequate grounding and/or shorting of electrical connections can cause high current arcing, which can cause personal injury and/or severe vehicle damage, including fire.
4. Proper placement and installation are vital to the performance of this warning device. Install this product so that output performance of the system is maximized and the controls are placed within convenient reach of the operator so that s/he can operate the system without losing eye contact with the roadway.
5. Do not install this product or route any wires in the deployment area of an air bag. Equipment mounted or located in an air bag deployment area may reduce the effectiveness of the air bag or become a projectile that could cause serious personal injury or death. Refer to the vehicle owner's manual for the air bag deployment area. It is the responsibility of the user/operator to determine a suitable mounting location ensuring the safety of all passengers inside the vehicle particularly avoiding areas of potential head impact.
6. It is the responsibility of the vehicle operator to ensure during use that all features of this product work correctly. In use, the vehicle operator should ensure the projection of the warning signal is not blocked by vehicle components (i.e., open trunks or compartment doors), people, vehicles or other obstructions.
7. The use of this or any other warning device does not ensure all drivers can or will observe or react to a warning signal. Never take the right-of-way for granted. It is your responsibility to be sure you can proceed safely before entering an intersection, driving against traffic, responding at a high rate of speed, or walking on or around traffic lanes.
8. This equipment is intended for use by authorized personnel only. The user is responsible for understanding and obeying all laws regarding warning signal devices. Therefore, the user should check all applicable city, state, and federal laws and regulations. The manufacturer assumes no liability for any loss resulting from the use of this warning device.

**Important!** This unit is a safety device and it must be connected to its own separate, fused power point to assure its continued operation should any other electrical accessory fail.

**Caution:** When drilling into any vehicle surface, make sure the area is free from any electrical wires, fuel lines, vehicle upholstery, etc. that could be damaged

**Notes:**

1. Larger wires and tight connections will provide longer service life for components. For high current wires it is highly recommended that terminal blocks or soldered connections be used with shrink tubing to protect the connections. Do not use insulation displacement connectors (e.g., 3M Scotchlock type connectors).
2. Route wiring using grommets and sealant when passing through compartment walls. Minimize the number of splices to reduce voltage drop. High ambient temperatures (e.g., under-bonnet(hood)) will significantly reduce the current carrying capacity of wires, fuses and circuit breakers. All wiring should conform to the minimum wire size and other recommendations of the manufacturer and be protected from moving parts and hot surfaces. Looms, grommets, cable ties, and similar installation hardware should be used to anchor and protect all wiring.
3. Fuses or circuit breakers should be located as close to the power takeoff points as possible and properly sized to protect the wiring and devices.
4. Particular attention should be paid to the location and method of making electrical connections and splices to protect these points from corrosion and loss of conductivity.
5. Ground termination should only be made to substantial chassis components, preferably directly to the vehicle battery.
6. Circuit breakers are very sensitive to high temperatures and will "false trip" when mounted in hot environments or operated close to their capacity.

**Wires:**

RED: = POSITIVE (+VE)

BLACK: = GND

**Flash Patterns:**

Pattern No.	Description	Phase	Other
1	135 DFPM $\pm$ 15 (Double flashes per minute)	A	ECE R65 Approved.

**Specifications:**

Voltage Supply (+VE): 10-36V DC

Current Consumption: 1.85A @ 12V DC

Peak Power: 23W @ 24V DC

Temperature Range: -20°C to 50°C

### **3 BOLT FIXING VERSION**

**TO ENSURE A WEATHERPROOF INSTALLATION THE BEACON MUST BE FITTED WITH THE SUPPLIED GASKET AND MOUNTED ON A FLAT PANEL OR SURFACE FORMING PART OF A WEATHERPROOF ENCLOSURE.**

Drill the panel or surface to accept the wires and the 3 M6 screws (see figure 1).

Connect the 2 wires to an appropriate power source ensuring that the RED wire is connected to the POSITIVE terminal of the supply via a suitable 3A fuse.

Fit the fibre washers under the screw heads to prevent water ingress and fix using the shakeproof washers and nuts. The rubber grommet supplied may be used to protect the wires when the beacon is panel mounted. The grommet is designed to fit a hole 6mm dia with panel thickness of 1.5-2mm.

### **SINGLE BOLT FIXING VERSION**

**TO ENSURE A WEATHERPROOF INSTALLATION THE BEACON MUST BE FITTED WITH THE SUPPLIED GASKET AND MOUNTED ON A FLAT PANEL OR SURFACE.**

Drill the panel or surface to accept the M12 threaded bolt.

Fit the beacon in the required position, first passing the wires and bolt through the pre-drilled hole. Secure using the M12 half nut and washer supplied.

Connect the 2 wires to an appropriate power source ensuring that the RED wire is connected to the POSITIVE terminal of the supply via a suitable 3A fuse.

### **MAGNETIC BASE VERSION**

**THE BEACON MUST BE FITTED ON A FLAT PART OF A STEEL ROOF OR PANEL.**

Check that the vehicle battery voltage is compatible with the beacon to be fitted. The connection to the beacon must be fitted with a suitable 3A fuse.

Wipe the roof of the vehicle where the beacon is to be placed to remove any debris or grease, and ensure that the foam gasket is clean, dry and in good condition. Place the beacon in the required position and connect to the vehicle battery supply using the cigar plug.

Note: In appreciation of the Consumer Protection Act 1987, covering product liability, and because of the nature and use of magnetic beacons, ECCO are obliged to make the following maximum speed recommendation for vehicles fitted with magnetic beacons:

**WE CAN ONLY RECOMMEND THE FITTING OF A ECCO MAGNETIC BEACON IF THE VEHICLE TO WHICH IT IS FITTED DOES NOT EXCEED A SPEED OF 70 M.P.H. FOR SPEEDS BETWEEN 40 AND 70 M.P.H., WE RECOMMEND THE USE OF A SUITABLE RESTRAINING DEVICE.**

Fig.1.

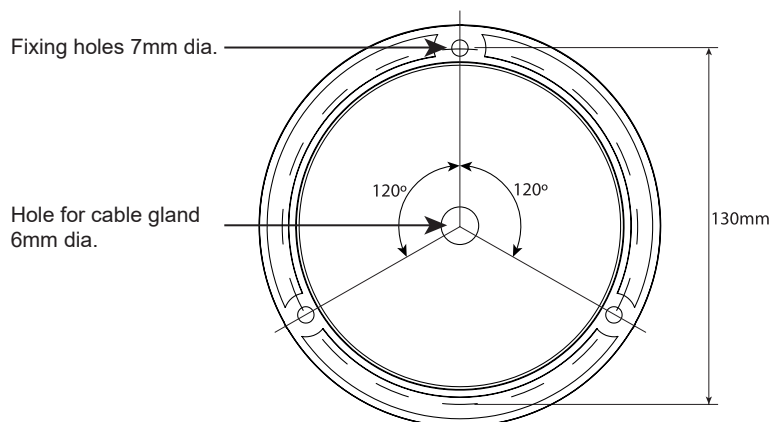

---

## **Electronics Controls Company “ECCO” (Manufacturer)**

ECCO warrants that on the date of purchase, this product will conform to ECCO’s specifications for this product (which are available from ECCO upon request). This Limited Warranty extends for thirty six (36) months from the date of purchase.

DAMAGE TO PARTS OR PRODUCTS RESULTING FROM TAMPERING, ACCIDENT, ABUSE, MISUSE, NEGLIGENCE, UNAPPROVED MODIFICATIONS, FIRE OR OTHER HAZARD; IMPROPER INSTALLATION OR OPERATION; OR NOT BEING MAINTAINED IN ACCORDANCE WITH THE MAINTENANCE PROCEDURES SET FORTH IN ECCO’S INSTALLATION AND OPERATING INSTRUCTIONS VOIDS THIS LIMITED WARRANTY.

### **Exclusion of Other Warranties:**

ECCO MAKES NO OTHER WARRANTIES, EXPRESSED OR IMPLIED. THE IMPLIED WARRANTIES FOR MERCHANTABILITY, QUALITY OR FITNESS FOR A PARTICULAR PURPOSE, OR ARISING FROM A COURSE OF DEALING, USAGE OR TRADE PRACTICE ARE HEREBY EXCLUDED AND SHALL NOT APPLY TO THE PRODUCT AND ARE HEREBY DISCLAIMED, EXCEPT TO THE EXTENT PROHIBITED BY APPLICABLE LAW. ORAL STATEMENTS OR REPRESENTATIONS ABOUT THE PRODUCT DO NOT CONSTITUTE WARRANTIES.

### **Remedies and Limitation of Liability:**

ECCO’S SOLE LIABILITY AND BUYER’S EXCLUSIVE REMEDY IN CONTRACT, TORT (INCLUDING NEGLIGENCE), OR UNDER ANY OTHER THEORY AGAINST ECCO REGARDING THE PRODUCT AND ITS USE SHALL BE, AT ECCO’S DISCRETION, THE REPLACEMENT OR REPAIR OF THE PRODUCT, OR THE REFUND OF THE PURCHASE PRICE PAID BY BUYER FOR NON-CONFORMING PRODUCT. IN NO EVENT SHALL ECCO’S LIABILITY ARISING OUT OF THIS LIMITED WARRANTY OR ANY OTHER CLAIM RELATED TO THE ECCO’S PRODUCTS EXCEED THE AMOUNT PAID FOR THE PRODUCT BY BUYER AT THE TIME OF THE ORIGINAL PURCHASE. IN NO EVENT SHALL ECCO BE LIABLE FOR LOST PROFITS, THE COST OF SUBSTITUTE EQUIPMENT OR LABOUR, PROPERTY DAMAGE, OR OTHER SPECIAL, CONSEQUENTIAL, OR INCIDENTAL DAMAGES BASED UPON ANY CLAIM FOR BREACH OF CONTRACT, IMPROPER INSTALLATION, NEGLIGENCE, OR OTHER CLAIM, EVEN IF ECCO OR A REPRESENTATIVE OF ECCO HAS BEEN ADVISED OF THE POSSIBILITY OF SUCH DAMAGES. ECCO SHALL HAVE NO FURTHER OBLIGATION OR LIABILITY WITH RESPECT TO THE PRODUCT OR ITS SALE, OPERATION AND USE, AND ECCO NEITHER ASSUMES NOR AUTHORIZES THE ASSUMPTION OF ANY OTHER OBLIGATION OR LIABILITY IN CONNECTION WITH SUCH PRODUCT.

**This Limited Warranty defines specific legal rights. You may have other legal rights which vary from jurisdiction to jurisdiction. Some jurisdictions do not allow the exclusion or limitation of incidental or consequential damages.**