



# DIRECTIONALS



## ED5051VDL2 Series

### Deck, Dash & Visor Light

ECCO's low-profile ED5051VDL2 deck, dash and visor light delivers discreet warning wherever an interior light is needed in a work truck or any fleet vehicle. Permanently or temporarily mount the warning light with included brackets using suction cups, tape or screws. The dual-colour LED light heads are available in combinations of white and amber colours, which are capable of producing 67 flash patterns including steady-burn. The cigarette plug adapter also includes a simple two-button controller. The removable shroud prevents unwanted flash back from the windshield.

#### Design Features

- 67 flash patterns
- Contains two ED5051 dual-colour lightheads in a compact unit
- Sleek design for low-profile applications
- Removable visor hood for versatile use on deck, dash or windows
- Multiple brackets included for permanent mount (screws or tape) or temporary mount (suction cups)
- Cigarette plug adapter and controller with flash pattern selector
- Temperature range: -40°C to 65°C (-40°F to 149°F)

#### Models

PART NO.	LED COLOUR	VDC	AMPS
ED5051VDL2-AW		12-24	1.7

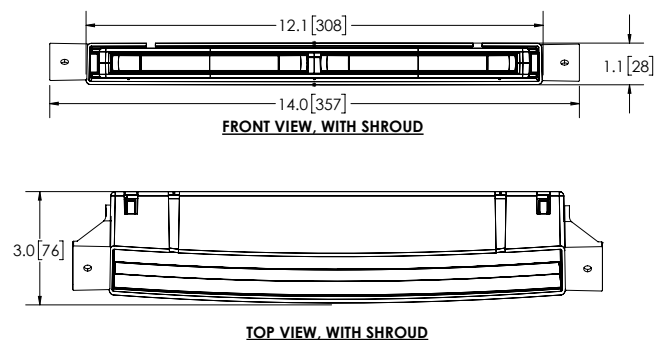
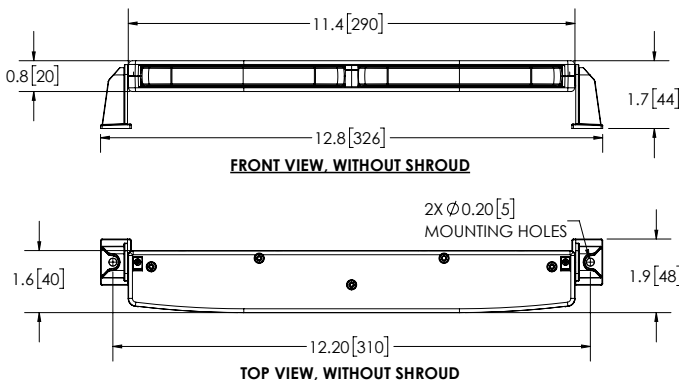

T: 1800 025 921 | E: [aftermarket@esg.global](mailto:aftermarket@esg.global)