



BEACONS

 7975 &
7980
Only

 EB7930 &
EB7935
Only

7900 SERIES - Heavy Duty

SAE Class I & II LED - Severe Vibration Applications

ECCO's Heavy Duty 7900 Series LED beacons feature encapsulated electronics and are ideally suited to severe vibration applications including mining, construction and waste management. SAE Class I models feature an aluminum base and SAE Class II models feature a reinforced polypropylene base, both models are available with either a 5" or 7" height profile. Each version offers a combined 3 bolt/1" pipe mounting and a 2-year warranty.

Models

PART NO.	VOLTAGE	AMPS	PROFILE	BASE	SAE
EB7930X	12-48	1.3	5"	Polypropylene	II
EB7935X	12-48	1.3	7"	Polypropylene	II
7975X	12-24	3.6	5"	Aluminum	I
7980X	12-24	3.6	7"	Aluminum	I

Replace X in part number with desired color: A = amber, B = blue, C = clear, G = green, R = red

Features and Benefits

- 11 flash patterns
- Encapsulated electronics provide enhanced protection against dust, moisture and vibration
- 7975/7980 = Aluminum base
- EB7930/EB7935 = Reinforced polypropylene base
- Temperature Range: -22°F to +122°F (-30°C to +50°C)

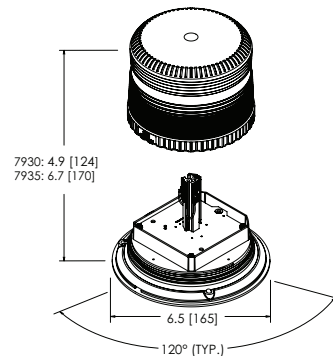
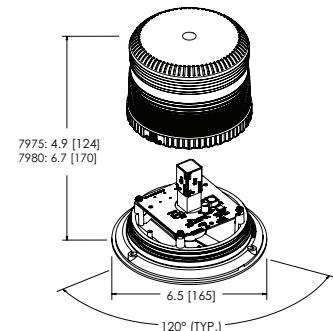

Parts & Accessories

- Lenses: EB7930/7975 - R6050LX
EB7935/7980 - R6070LX