

HYDROCOIL[®]
embolic system

with

V-Trak[®] Delivery System

Instructions for Use

 MicroVention[®]
TERUMO

HydroCoil® Embolic System (HES) with the HydroSoft®, HydroFill®, and HydroFrame® Endovascular Embolization Coils Instructions for Use

DEVICE DESCRIPTION

The MicroVention HydroCoil Embolic System (HES) consists of an implantable coil attached to a delivery system called a V-Trak® delivery pusher. The HES coils are platinum coils augmented with a hydrophilic polymer. The V-Trak® delivery pusher is powered by a V-Grip® detachment controller, which is provided separately.

The HES is available in several coil types based on the coil primary diameter and configuration. Each coil type must be delivered only through a wire-reinforced microcatheter with the minimum inner diameter specified. Within each coil type is a broad range of coil secondary (loop) diameters and lengths.

It is not necessary to pre-soften the HydroFrame®, HydroSoft®, or HydroFill® implants.

Table 1

| Coil Type | Stretch Resistant | Minimum Microcatheter I.D. | | Reposition Time | Gel Expansion Properties | |
|----------------------------|-------------------|----------------------------|------|-----------------|--------------------------|----------------|
| | | inches | mm | | To Coil OD | Beyond Coil OD |
| HydroFrame®10 | ● | 0.0165 | 0.42 | 30 minutes | ● | |
| HydroFrame®18 | ● | 0.0165 | 0.42 | 30 minutes | ● | |
| HydroSoft® | ● | 0.0165 | 0.42 | 30 minutes | ● | |
| HydroFill® (2 mm–4 mm) | ● | 0.0165 | 0.42 | 30 minutes | | ● |
| HydroFill® (5 mm–24 mm) | ● | 0.0165 | 0.42 | 10 minutes | | ● |
| HydroFill® (2 mm–24 mm) | ● | 0.021 | 0.53 | 30 minutes | | ● |

INDICATIONS FOR USE

The HydroCoil Embolic System (HES) is intended for the endovascular embolization of intracranial aneurysms and other neurovascular abnormalities such as arteriovenous malformations and arteriovenous fistulae. The HES is also intended for vascular occlusion of blood vessels within the neurovascular system to permanently obstruct blood flow to an aneurysm or other vascular malformation and for arterial and venous embolizations in the peripheral vasculature.

The device should only be used by physicians who have undergone pre-clinical training in all aspects of HES procedures as prescribed by MicroVention.

POTENTIAL COMPLICATIONS

Potential complications include, but are not limited to: hematoma at the site of entry, vessel perforation, aneurysm rupture, parent artery occlusion, incomplete aneurysm filling, emboli, hemorrhage, ischemia, vasospasm, coil migration or misplacement, premature or difficult coil detachment, clot formation, revascularization, post-embolization syndrome, and neurological deficits including stroke and possibly death.

Cases of chemical aseptic meningitis, edema, hydrocephalus and/or headaches have been associated with the use of embolization coils in the treatment of large and giant aneurysms. The physician should be aware of these complications and instruct patients when indicated. Appropriate patient management should be considered.

REQUIRED ADDITIONAL ITEMS

- MicroVention V-Grip® detachment controller
- Wire-reinforced microcatheter with 2 tip RO markers, appropriately sized
- Guide catheter compatible with microcatheter
- Steerable guidewires compatible with microcatheter
- 2 rotating hemostatic Y valves (RHV)
- 1 three-way stopcock
- MicroVention framing coils, size appropriate for aneurysm
- Sterile saline and/or lactated Ringer's injection
- Pressurized sterile saline drip
- 1 one-way stopcock
- Stopwatch or timer

WARNINGS AND PRECAUTIONS

Federal law (USA) restricts this device to sale by
or on the order of a physician.

- The HES is sterile and non-pyrogenic unless the unit package is opened or damaged.
- The HES is intended for single use only. Do not resterilize and/or reuse the device. After use, dispose in accordance with hospital, administrative and/or local government policy. Do not use if the packaging is breached or damaged.

- The HES must be delivered only through a wire-reinforced microcatheter with a PTFE inner surface coating. Damage to the device may occur and necessitate removal of both the HES and microcatheter from the patient.
- High quality, digital subtraction fluoroscopic road mapping is **mandatory** to achieve correct placement of the HES.
- Do not advance the V-Trak® delivery pusher with excessive force. Determine the cause of any unusual resistance, remove the HES and check for damage.
- Advance and retract the HES device slowly and smoothly. Remove the entire HES if excessive friction is noted. If excessive friction is noted with a second HES, check the microcatheter for damage or kinking.
- The coil must be properly positioned in the aneurysm within the specified reposition time. The reposition time is the time between introduction of the device into the microcatheter and the time of detachment. If the coil cannot be positioned and detached within this time, simultaneously remove the device and the microcatheter. Positioning the device outside of an aneurysm may diminish the reposition time.
- If repositioning is necessary, take special care to retract the coil under fluoroscopy in a one-to-one motion with the V-Trak® delivery pusher. If the coil does not move in a one-to-one motion with the V-Trak® delivery pusher, or if repositioning is difficult, the coil may have become stretched and could possibly break. Gently remove and discard the entire device.
- Due to the delicate nature of the HES coils, the tortuous vascular pathways that lead to certain aneurysms and vessels, and the varying morphologies of intracranial aneurysms, a coil may occasionally stretch while being maneuvered. Stretching is a precursor to potential coil breakage and migration.
- If a coil must be retrieved from the vasculature after detachment, do not attempt to withdraw the coil with a retrieval device, such as a snare, into the delivery catheter. This could damage the coil and result in device separation. Remove the coil, microcatheter, and any retrieval device from the vasculature simultaneously.
- If resistance is encountered while withdrawing a coil that is at an acute angle relative to the microcatheter tip, it is possible to avoid coil stretching or breaking by carefully repositioning the distal tip of the catheter at, or slightly inside, the ostium of the aneurysm. By doing so, the aneurysm and artery act to funnel the coil back into the microcatheter.
- Delivery of multiple HES coils is usually required to achieve the desired occlusion of some aneurysms or lesions. The desired procedural endpoint is angiographic occlusion. The filling properties of the HES coils facilitate angiographic occlusion and reduce the need to tightly pack.
- The long-term effect of this product on extravascular tissues has not been established so care should be taken to retain this device in the intravascular space.
- Always ensure that at least two MicroVention V-Grip® detachment controllers are available before starting a HES procedure.
- The HES cannot be detached with any power source other than a MicroVention V-Grip® detachment controller.
- Always advance an appropriately sized guidewire through the microcatheter after detaching the coil and removing the pusher to ensure that no part of the coil remains within the microcatheter.
- Do **NOT** place the V-Trak® delivery pusher on a bare metallic surface.
- Always handle the V-Trak® delivery pusher with surgical gloves.
- Do **NOT** use in conjunction with radio frequency (RF) devices.
- No modification of this equipment is allowed.

CATHETERIZATION OF THE LESION

1. Refer to the set-up diagram.
2. Using standard interventional procedures, access the vessel with a guide catheter. The guide catheter should have an inner diameter (ID) large enough to allow for contrast injection while the microcatheter is in place. This will allow for fluoroscopic road mapping during the procedure.
3. Attach a rotating hemostatic valve (RHV) to the hub of the guiding catheter. Attach a 3-way stopcock to the side arm of the RHV and then connect a line for continuous infusion of flush solution.
4. Select a microcatheter with the appropriate inner diameter. After the microcatheter has been positioned inside the lesion, remove the guidewire.
5. Attach a second RHV to the hub of the microcatheter. Attach a 1-way stopcock to the sidearm of the second RHV and connect the flush solution line to the stopcock.
6. Open the stopcock to allow flush through microcatheter with sterile flush solution. To minimize the risk of thromboembolic complications, it is critical that a continuous infusion of appropriate sterile flush solution be maintained into the guide catheter, the femoral sheath and the microcatheter.

COIL SIZE SELECTION

7. Perform fluoroscopic road mapping.
8. Measure and estimate the size of the lesion to be treated.
9. Select the appropriately sized coils. One or more framing coils should be used to establish the initial framework. The diameter of the first and second coils should never be less than the width of the aneurysm neck or the propensity for the coils to migrate may be increased.
10. Correct coil selection increases effectiveness and patient safety. Occlusive efficiency is, in part, a function of compaction and overall coil mass. In order to choose the optimum coil for any given lesion, examine the pre-treatment angiograms. The appropriate coil size should be chosen based upon angiographic

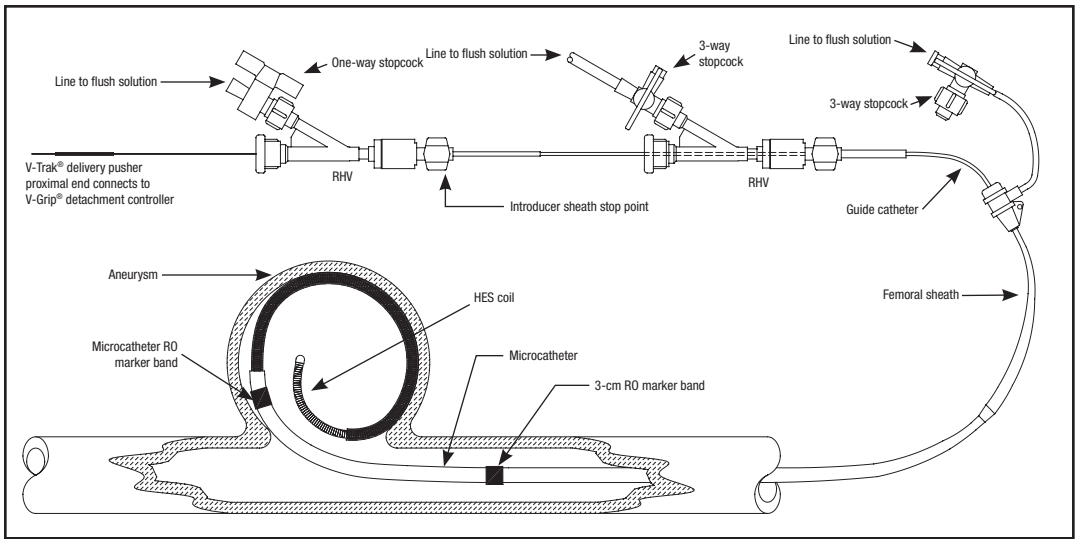
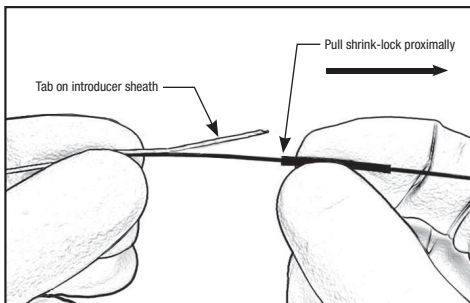

Diagram of HES Setup

assessment of the diameter of the parent vessel, aneurysm dome and aneurysm neck.

PREPARATION OF THE HES FOR DELIVERY

- Remove the V-Grip® detachment controller from its protective packaging. Pull the white pull-tab from the side of the detachment controller. Discard the pull-tab and place the detachment controller in the sterile field. The V-Grip® detachment controller is packaged separately as a sterile device. **Do not use any power source other than the MicroVentation V-Grip® detachment controller to detach the coil. The V-Grip® detachment controller is intended to be used on one patient. Do not attempt to re-sterilize or otherwise re-use the V-Grip® detachment controller.**
- Prior to using the device, remove the proximal end of the V-Trak® delivery pusher from the packaging hoop. Use care to avoid contaminating this end of the delivery pusher with foreign substances such as blood or contrast. Firmly insert the proximal end of the delivery pusher into the funnel section of the V-Grip® detachment controller. **Do not push the detachment button at this time.**
- Wait three seconds and observe the indicator light on the detachment controller.
 - If the green light does not appear or if a red light appears, replace the device.
 - If the light turns green, then turns off at any time during the three-second observation, replace the device.
 - If the green light remains solid green for the entire three-second observation, continue using the device.
- Hold the device just distal to the shrink-lock and pull the shrink-lock proximally to expose the tab on introducer sheath.



Pull Shrink-Lock Proximally

- Slowly advance the HES implant out of the introducer sheath and inspect the coil for any irregularities or damage. **If any damage to the coil or V-Trak® delivery pusher is observed, DO NOT use the device.**
- While holding the introducer sheath vertically, gently retract the coil back into the introducer sheath about 1 to 2 cm.

INTRODUCTION AND DEPLOYMENT OF THE HES

- Open the RHV on the microcatheter just enough to accept the introducer sheath of the HES.
- Insert the introducer sheath of the HES through the RHV. Flush the introducer until it is completely purged of air and saline flush exits the proximal end.
- Seat the distal tip of the introducer sheath at the distal end of the microcatheter hub and close the RHV **lightly** around the introducer sheath to secure the RHV to the introducer. **Do not over-tighten the RHV around the introducer sheath. Excessive tightening could damage the device.**
- Push the coil into the lumen of the microcatheter. Use caution to avoid catching the coil on the junction between the introducer sheath and the hub of the microcatheter. **Initiate timing using a stopwatch or timer at the moment the device enters the microcatheter. Detachment must occur within the specified reposition time.**
- Push the HES through the microcatheter until the proximal end of the V-Trak® delivery pusher meets the proximal end of the introducer sheath. Loosen the RHV. Retract the introducer sheath just out of the RHV. Close the RHV around the V-Trak® delivery pusher. Slide the introducer sheath completely off of the V-Trak® delivery pusher. Use care not to kink the delivery system. To prevent premature hydration of the HES, ensure that there is flow from the saline flush.
- Discard the introducer sheath. The HES cannot be re-sheathed after introduction into the microcatheter.
- Carefully advance the HES until the coil exit marker on the proximal end of the V-Trak® delivery pusher approaches the RHV on the hub of the microcatheter. At this time, fluoroscopic guidance must be initiated.

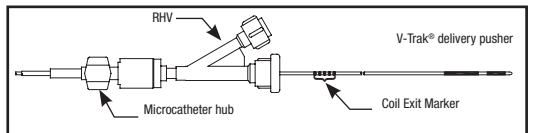

V-Trak® Delivery Pusher and Coil Exit Marker

- Under fluoroscopic guidance, slowly advance the HES coil out the tip of the microcatheter. Continue to advance the HES coil into the lesion until optimal deployment is achieved. Reposition if necessary. If the coil size is not suitable, remove and replace with another device. If undesirable movement of the coil is observed under fluoroscopy following placement and prior to detachment, remove

the coil and replace with another more appropriately sized coil. Movement of the coil may indicate that the coil could migrate once it is detached. **DO NOT** rotate the V-Trak® delivery pusher during or after delivery of the coil into the aneurysm. Rotating the HES V-Trak® delivery pusher may result in a stretched coil or premature detachment of the coil from the V-Trak® delivery pusher, which could result in coil migration. Angiographic assessment should also be performed prior to detachment to ensure that the coil mass is not protruding into the parent vessel.

25. Complete the deployment and any repositioning so that the coil will be detached within the reposition time specified in Table 1. After the specified time, the swelling of the hydrophilic polymer may prevent passage through the microcatheter and damage the coil. **If the coil cannot be properly positioned and detached within the specified time, simultaneously remove the device and the microcatheter.**
26. Advance the coil into the desired site until the radiopaque proximal marker on the delivery system is aligned with the proximal marker on the microcatheter as shown.

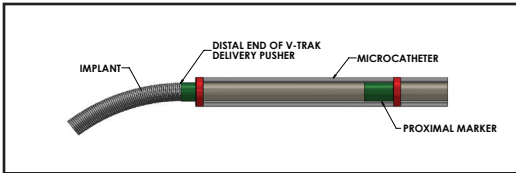

27. Tighten the RHV to prevent movement of the coil.
28. Verify repeatedly that the distal shaft of the V-Trak® delivery pusher is not under stress before coil detachment. Axial compression or tension could cause the tip of the microcatheter to move during coil delivery. Catheter tip movement could cause the aneurysm or vessel to rupture.

DETACHMENT OF THE HES COIL

29. The V-Grip® detachment controller is pre-loaded with battery power and will activate when a MicroVentation V-Trak® delivery pusher is properly connected. It is not necessary to push the button on the side of the V-Grip® detachment controller to activate it.
30. Verify that the RHV is firmly locked around the V-Trak® delivery pusher before attaching the V-Grip® detachment controller to ensure that the coil does not move during the connection process.
31. Although the V-Trak® delivery pusher's gold connectors are designed to be compatible with blood and contrast, every effort should be made to keep the connectors free of these items. If there appears to be blood or contrast on the connectors, wipe the connectors with sterile water or saline solution before connecting the V-Grip® detachment controller.
32. Connect the proximal end of the V-Trak® delivery pusher to the V-Grip® detachment controller by firmly inserting the proximal end of the V-Trak® delivery pusher into the funnel section of the V-Grip® detachment controller.

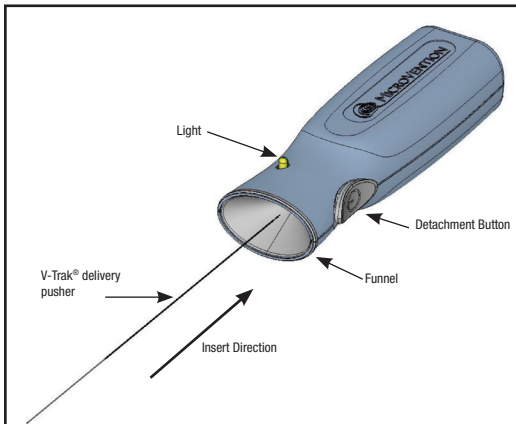

V-Grip® Detachment Controller

33. When the V-Grip® detachment controller is properly connected to the V-Trak® delivery pusher, a single audible tone will sound and the light will turn green to signal that it is ready to detach the coil. If the detachment button is not pushed within 30 seconds, the solid green light will slowly flash green. Both flashing green and solid green lights indicate that the device is ready to detach. If the green light does not appear, check to ensure that the connection has been made. If the connection is correct and no green light appears, replace the V-Grip® detachment controller.

34. Verify the coil position before pushing the detachment button.
35. Push the detachment button. When the button is pushed, an audible tone will sound and the light will flash green.
36. At the end of the detachment cycle, three audible tones will sound and the light will flash yellow three times. This indicates that the detachment cycle is complete. If the coil does not detach during the detachment cycle, leave the V-Grip® detachment controller attached to the V-Trak® delivery pusher and attempt another detachment cycle when the light turns green.
37. The light will turn red after the number of detachment cycles specified on the V-Grip® labeling. **DO NOT** use the V-Grip® detachment controller if the light is red. Discard the V-Grip® detachment controller and replace it with a new one when the light is red.
38. Verify detachment of the coil by first loosening the RHV valve, then pulling back slowly on the delivery system and verifying that there is no coil movement. If the implant did not detach, do not attempt to detach it more than two additional times. If it does not detach after the third attempt, remove the delivery system.
39. After detachment has been confirmed, slowly retract and remove the delivery pusher. **Advancing the V-Trak® delivery pusher once the coil has been detached involves risk of aneurysm or vessel rupture. Do NOT advance the delivery pusher once the coil has been detached.**
40. Verify the position of the coil angiographically through the guide catheter.
41. Prior to removing the microcatheter from the treatment site, place an appropriately sized guidewire completely through the microcatheter lumen to ensure that no part of the coil remains within the microcatheter.

The physician has the discretion to modify the coil deployment technique to accommodate the complexity and variation in embolization procedures. Any technique modifications must be consistent with the previously described procedures, warnings, precautions and patient safety information.

SPECIFICATIONS FOR V-GRIP® DETACHMENT CONTROLLER

- Output voltage: 9 ± 0.5 VDC
- Cleaning, preventative inspection, and maintenance: The V-Grip® detachment controller is a single use device, preloaded with battery power, and packaged sterile. No cleaning, inspection, or maintenance is required. If the device does not perform as described in the Detachment section of these Instructions, discard the V-Grip® detachment controller and replace it with a new unit.
- The V-Grip® detachment controller is a single use device. It should not be cleaned, re-sterilized, or re-used.
- The V-Grip® detachment controller is a Type BF Applied Part.
- Batteries are pre-loaded into the V-Grip® detachment controllers. Do not attempt to remove or replace the batteries prior to use.
- After use:
 - a. If the model has an accessible battery compartment, the battery can be removed from the V-Grip® detachment controller using a tool, such as a flathead screwdriver, and disposed of in a manner consistent with local regulations. After battery removal, dispose of the V-Grip® detachment controller in accordance with local regulations.
 - b. If the model does not have an accessible battery compartment, dispose of the V-Grip® detachment controller in a manner consistent with local regulations.

PACKAGING AND STORAGE

The HES is placed inside a protective, plastic dispenser hoop and packaged in a pouch and unit carton. The HES and dispenser hoop will remain sterile unless the package is opened, damaged, or the expiration date has passed. Store at a controlled room temperature in a dry place.

The V-Grip® detachment controller is packaged separately in a protective pouch and carton. The V-Grip® detachment controller has been sterilized; it will remain sterile unless the pouch is opened, damaged, or the expiration date has passed. Store at a controlled room temperature in a dry place.

SHELF LIFE

See the product label for the device shelf life. Do not use the device beyond the labeled shelf life.



MR INFORMATION

The HydroCoil Embolic System (HES) implant has been determined to be **MR conditional** according to the terminology specified in the American Society for Testing and Materials (ASTM) International, Designation: F2503-08.

Non-clinical testing demonstrated that the HES implant is **MR conditional**. A patient can be scanned safely, immediately after placement under the following conditions:

- Static magnetic field of 3 Tesla or less
- Maximum spatial gradient field of 720 Gauss/cm or less

MRI-Related Heating

In non-clinical testing, the HES implant produced a maximum temperature rise of 1.6°C during MRI performed for 15 minutes of scanning in the 3 Tesla (3-Tesla/128-MHz, Excite, HDx, Software 14X.M5, General Electric Healthcare, Milwaukee, WI) MR system.

Therefore, the MRI-related heating experiments for the HES implant at 3 Tesla using a transmit/receive RF body coil at an MR system reported whole body averaged SAR of 2.9 W/kg (i.e., associated with a calorimetry measured whole body averaged value of 2.7 W/kg) indicated that the greatest amount of heating that occurred in association with these specific conditions was equal to or less than 1.6°C.

Image Artifact Information

MR image quality may be compromised if the area of interest is in the exact same area or relatively close to the position of the HES implant. Therefore, optimization of MR imaging parameters to compensate for the presence of this device may be necessary.

| | | | | |
|--------------------|---------------------|--------------------|---------------------|---------------------|
| Pulse Sequence: | T1-SE | T1-SE | GRE | GRE |
| Plane Orientation: | Parallel | Perpendicular | Parallel | Perpendicular |
| Signal Void Size: | 400 mm ² | 70 mm ² | 532 mm ² | 196 mm ² |

MicroVention, Inc. recommends that the patient register the MR conditions disclosed in this IFU with the MedicAlert Foundation or equivalent organization.

MATERIALS

The HES does not contain latex or PVC materials.

WARRANTY

MicroVention, Inc. warrants that reasonable care has been used in the design and manufacture of this device. This warranty is in lieu of and excludes all other warranties not expressly set forth herein, whether expressed or implied by operation of law or otherwise, including, but not limited to, any implied warranties of merchantability or fitness. Handling, storage, cleaning and sterilization of the device as well as factors relating to the patient, diagnosis, treatment, surgical procedure and other matters beyond MicroVention's control directly affect the device and the results obtained from its use. MicroVention's obligation under this warranty is limited to the repair or replacement of this device and MicroVention shall not be liable for any incidental or consequential loss, damage or expense directly or indirectly arising from the use of this device. MicroVention neither assumes, nor authorizes any other person to assume for it, any other or additional liability or responsibility in connection with this device. MicroVention assumes no liability with respect to devices reused, reprocessed or resterilized and makes no warranties, expressed or implied, including, but not limited to, merchantability or fitness for intended use, with respect to such device.

Prices, specifications and model availability are subject to change without notice.



















© Copyright 2023 MicroVention, Inc. All rights reserved.

MicroVention®, HydroCoil®, HydroSoft®, HyperSoft®, MicroPlex®, HydroFill®, HydroFrame®, V-Grip® and V-Trak® are registered trademarks of MicroVention, Inc.

This product is covered by one or more of the following US patents: 6,500,190. Additional US and international patents are pending.

SYMBOLS

The following symbols are used:

| | |
|---|------------------------------------|
|  | Lot Number |
|  | Catalog Number |
|  | Content |
|  | Sterilized Using Irradiation |
|  | Sterilized Using Ethylene Oxide |
|  | Do Not Reuse |
|  | Use-by Date |
|  | Date of Manufacture |
|  | Warning |
|  | Follow Instructions for Use |
|  | CE Mark |
|  | Type BF Applied Part |
|  | Detachment/Stand-by |
|  | Manufacturer |
|  | Authorized European Representative |
|  | MR Conditional |
|  | Non-pyrogenic |
|  | Upper limit of temperature |



Manufacturer:

MicroVention, Inc.
35 Enterprise
Aliso Viejo, CA 92656 USA
Tel: 714.2478000
www.microvention.com



Authorized European Representative:

MicroVention Europe SARL
30 bis, rue du Vieil Abreuvoir
78100 Saint-Germain-en-Laye
France
Tel: +33 (1) 39 21 52 17
Fax: +33 (1) 39 21 16 01

