

EmPro™

Embolic Protection System

INSTRUCTIONS FOR USE



DEVICE DESCRIPTION

The MicroVention EmPro™ Embolic Protection System (EPS) is designed to capture and remove dislodged debris during a carotid interventional procedure. It consists of three basic components and additional accessories: 1) an embolic protection device (EPD) consisting of a nitinol braided mesh filter with an atraumatic distal tip built on an integrated .014" PTFE coated stainless steel capture delivery wire, 2) a 3.5F delivery catheter with 165 cm length, and 3) a 4.5F retrieval catheter with 150 cm working length. Accessories include a wire introducer, EPD loading cover, sheath introducer and a torque device. Catheters are provided in two separate dispenser coils. The EmPro EPS is used in conjunction with a primary .014" compatible wire (not included in package) with the rapid exchange port to gain access across the lesion site. The .014" integrated Capture delivery wire is used as the primary guidewire for interventional devices such as a stent or PTA balloon catheter compatible with a .014" or .018" wire. The EmPro EPD loading cover protects the filter, is used to flush and load the filter into the delivery catheter.

Figure 1.
EmPro EPD and Delivery Catheter Set-up

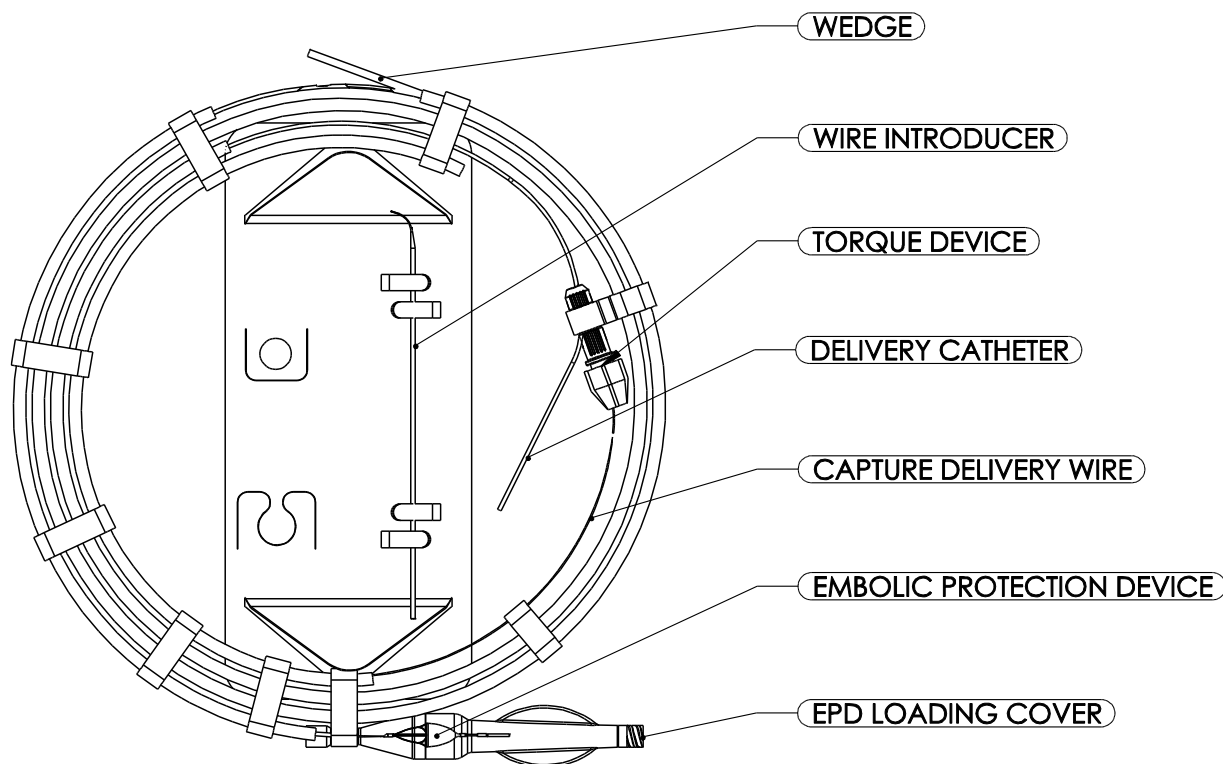

Figure 2.
EmPro Retrieval Catheter Set-up

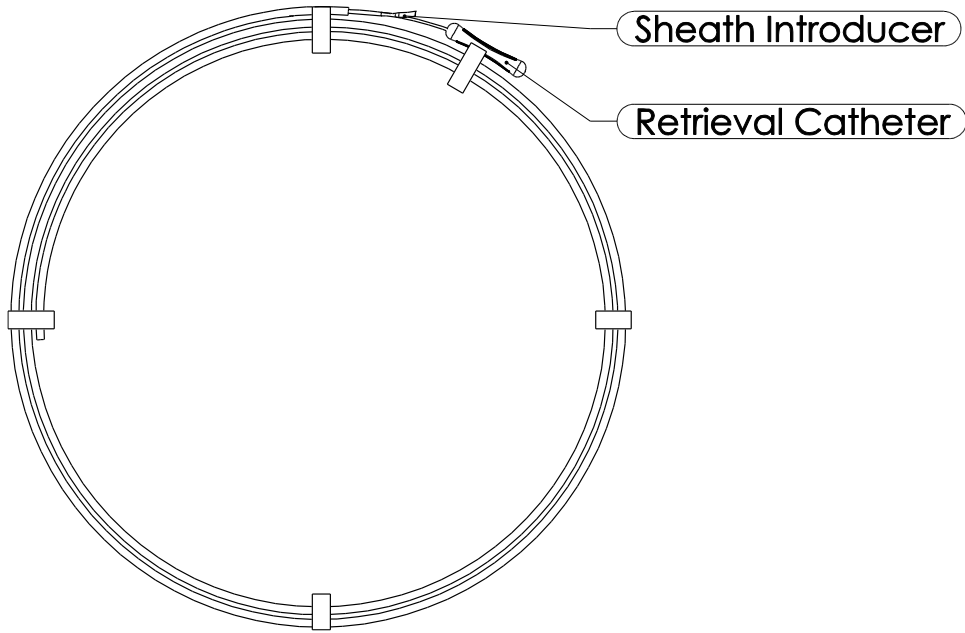
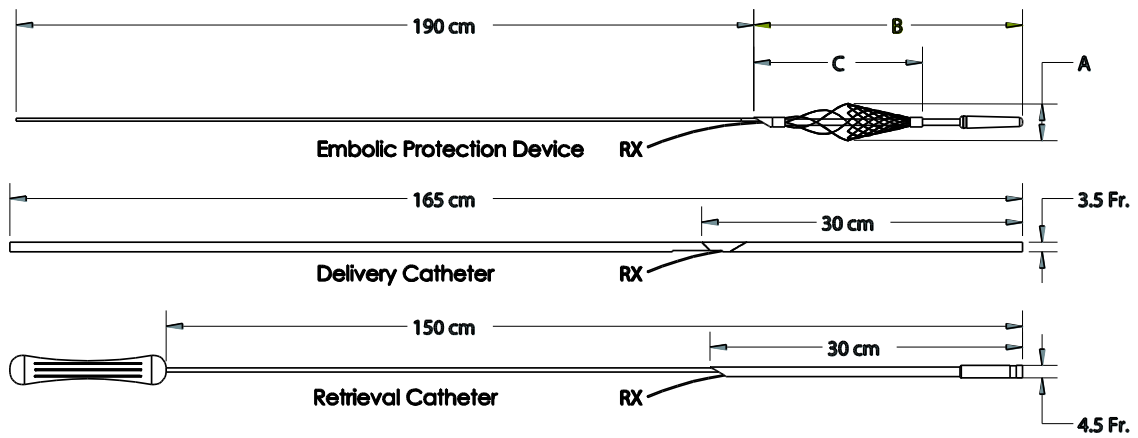

Figure 3.
EmPro EPS Dimensions



Catalog Number	System Size	Reference Vessel Size (mm)	A (mm)	B (mm)	C (mm)
EP4514C-190	Small	3.0 – 4.5	5.2	36.3	19.6
EP6514C-190	Large	4.5 – 6.5	7.2	42.7	23.1

INDICATIONS

The EmPro EPS is indicated for use as a guidewire to contain and remove embolic material (thrombus/debris) while performing angioplasty and stenting procedures in carotid arteries. The diameter of the artery at the site of the filter placement should be between 3.0 and 6.5 mm.

CONTRAINDICATIONS

The EmPro EPS is contraindicated for use in:

- Patients in whom anticoagulant, antiplatelet therapy or thrombolytic drugs is contraindicated
- Patients with known hypersensitivity to nickel-titanium
- Patients with severe vascular tortuosity or anatomy that would preclude the landing zone requirement or the safe introduction of a guide wire, guide catheter, introducer sheath, an embolic protection device, delivery catheter, or retrieval catheter.
- Patients with uncorrected bleeding disorders
- Lesions in the ostium of the common carotid artery

WARNINGS

Only physicians who have had appropriate training for carotid artery stenting and are familiar with the principles, clinical applications, complications, side effects and hazards commonly associated with carotid interventional procedures should use this device.

Refer to instructions supplied with all interventional devices to be used with the EmPro EPS for their intended uses, contraindications, and potential complications.

Safety and effectiveness of this device as an embolic protection system has not been established in coronary, cerebral or peripheral vasculatures.

The EmPro EPS is intended for one time use only. DO NOT re-sterilize and/or reuse it because it can potentially result in compromised device performance and risk of cross contamination.

The appropriate antiplatelet, anticoagulant and if necessary, vasodilator therapy, must be used during the pre- and post-procedure to minimize the risk of embolism and thrombus.

Avoid using power injection in the cerebral circulation.

Introduce and advance devices slowly to prevent the embolism or trauma to the vasculature.

Do not oversize or undersize the filter relative to the selected vessel diameter. This may result in inadequate vessel wall apposition or incomplete deployment of the filter. Undersizing or oversizing could cause no-flow or slow flow and/or embolism of debris.

Overstretching of the artery may result in rupture and life-threatening bleeding.

Minimize movement of the EmPro EPS after initial placement. Excessive movement of the capture delivery wire may lead to embolization of debris, and vessel and/or device damage.

Torquing the capture delivery wire against resistance may cause filter damage, wire damage, delivery tip separation and wire whipping.

Never withdraw or move an intravascular device against any resistance until the cause is determined. Applying excessive force during delivery or retrieval of the systems can potentially result in loss or damage to the devices and delivery components.

Allow for and maintain adequate distance between the filter (no less than 2.5 cm), the stent delivery system or deployed stent to avoid potential entanglement.

Do not attempt to reposition or remove the capture delivery wire without the use of the retrieval catheter. This may lead to embolization of debris, and vessel and/or device damage.

The maintenance of blood flow through the filter device should be observed throughout the procedure by use of fluoroscopy.

EmPro EPS has only been studied for compatible use with the CASPER™ stent and the safety and effectiveness of the device use with other stents has not been demonstrated.

PRECAUTIONS

Carefully inspect the sterile package and the EmPro EPS prior to use to verify that neither has been damaged during shipment. Do not use kinked or damaged components, or if the package is opened or damaged.

See the product label for shelf life. Do not use the EmPro EPS beyond the labeled use by date.

Confirm the compatibility of the EmPro EPS with the interventional devices before actual use.

Fully flush the EmPro EPS filter and rapid exchange (Rx) guidewire lumen of the delivery catheter. Do not use the delivery system if flush is not observed exiting at the Rx delivery catheter proximal port location.

Identify the delivery catheter and the primary 0.014" guidewire while advancing. Do not rotate the delivery catheter which can cause the primary wire to wrap around the catheter.

Use caution when withdrawing the EmPro EPS through the deployed stent. This may cause stent/filter entanglement, rupture and/or stent dislocation.

After use, dispose in accordance with hospital, administrative and/or local government policy.

Keep dry and away from sunlight.













POTENTIAL COMPLICATIONS







Possible complications include but are not limited to the following:

- Aneurysm and pseudoaneurysm formation
- Allergic reactions (including to antiplatelet agents, contrast medium or stent materials)
- Arteriovenous fistula
- Bacteremia or septicemia
- Bleeding from anticoagulation/antiplatelet medication
- Bradycardia and hypotension
- Cerebral edema
- Congestive Heart Failure
- Coronary ischemia
- Death

- Disseminated intravascular coagulation
- Emboli (air, tissue, plaque, thrombus, device or other)
- Emergent or urgent surgery
- Fever
- Filter thrombosis/occlusion
- Fluid overload
- Headache
- Hematoma
- Hemorrhagic or embolic stroke/Transient ischemic attack (TIA)
- Hyperperfusion syndrome
- Hypertension or Hypotension
- Infection and/or pain at insertion site/sepsis
- Intimal tear/dissection
- Ischemia/Infarction of tissue/organ
- Loss of all or part of the filter element
- Myocardial infarction (MI)
- New or worse encephalopathy
- Renal failure/insufficiency
- Respiratory arrest
- Seizure
- Stent/filter entanglement/damage
- Stroke or other neurological complications
- Thrombophlebitis
- Tissue necrosis
- Unstable angina pectoris
- Vascular access complications (e.g. loss of pulse, femoral artery pseudoaneurysm and infection)
- Vasospasm
- Vessel injury/dissection/perforation/rupture/trauma
- Vessel occlusion or thrombosis

SYMBOLS

	Batch code		Non-pyrogenic
	Medical device		Unique device identifier
	Sterilized using ethylene oxide		For prescription use only
	Use-by date		Manufacturer
	Keep away from sunlight		Consult instructions for use
	Keep dry		Do not use if package is damaged

	Single sterile barrier		Contents
	Country and Date of Manufacture		Catalog number
	Do not re-sterilize		Caution
	Do not reuse		

CLINICIAN USE INFORMATION

Materials

The EmPro EPS does not contain latex or PVC materials. The following parts are required to use the EmPro EPS:

Accessories for performing a procedure but NOT supplied should be selected based on the physician's experience and preferences:

- Appropriate guiding sheath or catheter with a minimum internal diameter (I.D.) of .074 in. (1.9 mm).
- .014" guidewire compatible with the EmPro EPS
- Saline solution/heparin-saline solution (sterile)
- 5 cc luer-lock syringe for flushing the EmPro EPS
- Contrast solution
- Rotating Hemostatic Valve (RHV)

PACKAGING AND STORAGE

The EmPro EPS is placed inside a protective package which includes two (2) sterile sealed pouches and unit carton. The EmPro EPS will remain sterile unless the package is opened, damaged, or the expiration date has passed. Keep dry and away from sunlight.

SHELF LIFE

See the product label for the device shelf life. Do not use the device beyond the labeled use by date.

PREPARATION FOR USE

Device and Delivery System Selection

Appropriate selection of the EmPro EPS is important for patient safety. In order to choose the optimal EmPro EPS filter size for any given carotid artery, examine pre-treatment angiograms for correct and accurate vessel measurements. Reference the Fig. 3 chart within the Instructions For Use or see the box label.

Directions for Use

EmPro EPS Preparation

Note: Only prepare and flush the delivery system within the provided packaging.

1. Remove the two pouches enclosing the EmPro EPS components from the carton.

Pouch 1: EmPro EPD, EmPro delivery catheter, wire introducer, torque device, EPD loading cover and dispenser coil

Pouch 2: EmPro Retrieval catheter, sheath introducer and dispenser coil

2. Inspect the pouches for any signs of damage to the sterile barrier.

Warning: If it is suspected that the sterile barrier seal has been opened or compromised, do not use the EmPro EPS and return to the manufacturer.

Delivery Device Preparation

1. Peel open pouch and remove the dispenser coil containing the EmPro EPD and EmPro delivery catheter.
2. Fill a 5-ml syringe with sterile heparinized saline solution. Remove air bubbles within the syringe. Attach the syringe to the luer lock on the EPD loading cover. While orienting the EPD loading cover and syringe vertically, inject into the EPD loading cover where the filter is located. Make sure all air bubbles from the filter are removed. Inject until saline is seen exiting the dispenser coil at where the wedge is located. See Figure Below.

WARNING: Do not remove the filter from the loading cover during this step.

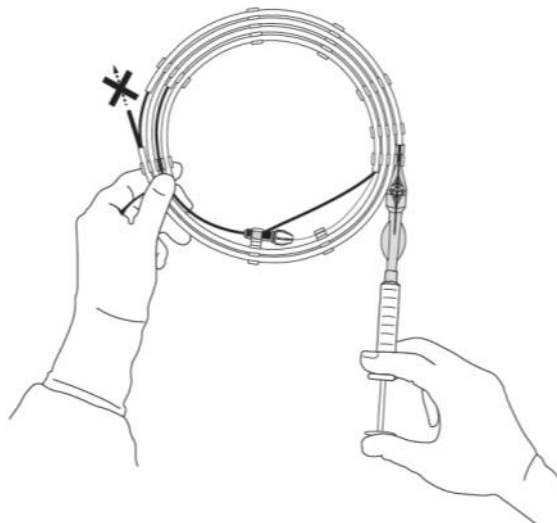

3. Unclip the torque device from the dispenser coil and ensure that the torque device is secured onto the capture delivery wire.
4. While securing the delivery catheter against the dispenser coil, pull on the torque device until the filter is withdrawn through the EPD loading cover and a hard stop is felt. Visually confirm that the distal tip of the delivery catheter has not migrated from within the proximal end of EPD loading cover and the EPD filter is fully loaded into the delivery catheter.

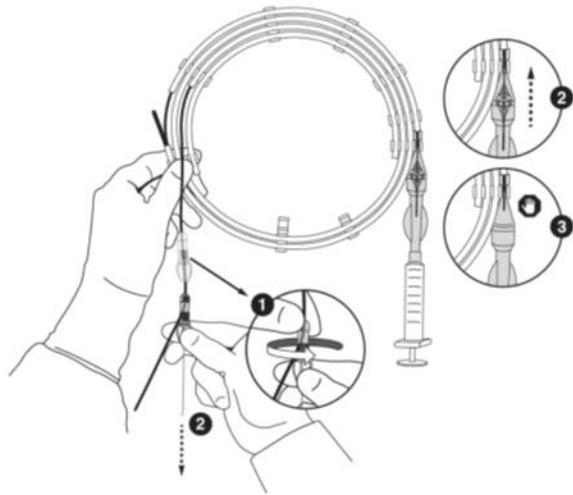

5. Remove the wedge from the dispenser coil.

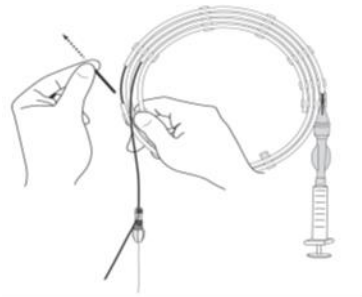

6. Remove the EPD system from the dispenser coil.

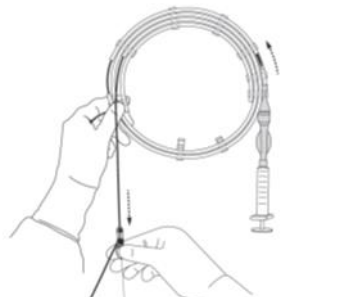

EmPro EPD Deployment

1. The EmPro EPS can be used with either an introducer sheath or guide catheter. A RHV should be used with the guide catheter. The internal diameter of the introducer sheath or guide catheter should be at least .074" or greater.
2. Advance a primary .014" guidewire (not supplied with EmPro EPS) beyond the target location to a minimum of 10 cm. Ensure adequate wire support is provided for the EPD system to advance to the

target location. A wire introducer is included to pass a hemostasis valve within a sheath or RHV device to prevent damage to the guidewire. See Figure Below.



3. Load the EPD system over the .014" primary guidewire. Ensure the primary guidewire exits the proximal RX port of the delivery catheter. If the primary wire hits a stop or resistance is felt, withdraw the primary and re-attempt to have the primary guidewire exit the RX port, a slight rotation of the delivery catheter may be required.
4. While maintaining position of the primary guidewire, advance the EPD and the delivery catheter slowly and deliberately beyond the lesion to a minimum of 8 cm. Perform device manipulation using fluoroscopic visualization. Do not advance any component of the EmPro EPS against any resistance. Do not torque the delivery catheter during advancement. See Figure Below.

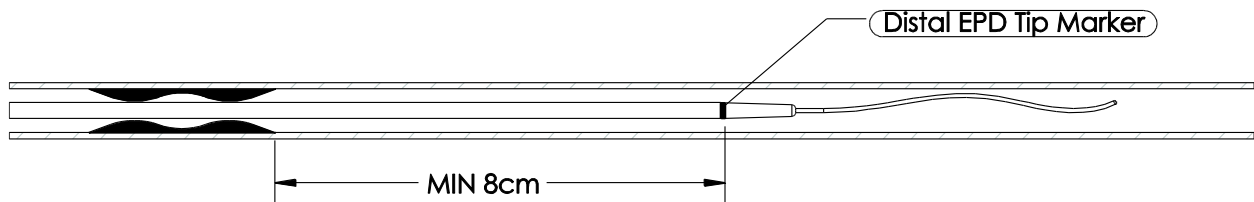

5. **Remove the primary .014" guidewire.**
6. Loosen the torque device and while holding the proximal delivery catheter end with the capture delivery wire, reposition the torque device against the RHV to ensure proper wire support for EPD deployment. Tighten the torque device onto the capture delivery wire.

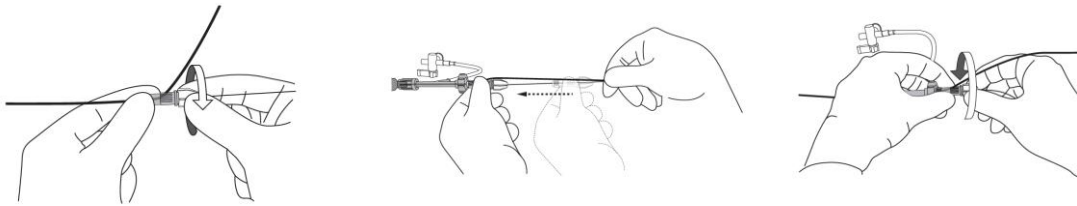

7. Before deploying the EPD filter, identify the desired stent location and ensure that there is adequate distance between the proximal tip of the filter element and the most distal tip of the interventional device to be introduced over the filter delivery wire to avoid contact during the procedure. The appropriate distance should be 2.5cm between the distal tip of the interventional device and proximal end of the filter. See Figure below.

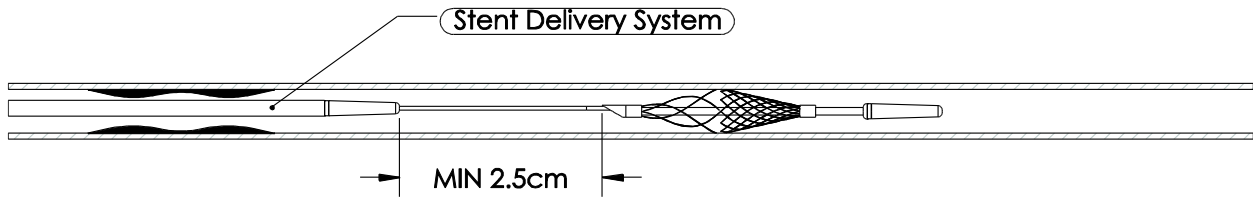

8. While maintaining position of the torque device, deploy the filter by pulling on the delivery catheter.

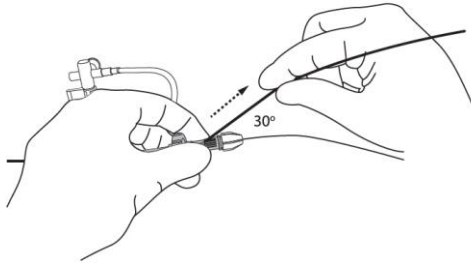

WARNING: Do not attempt to recapture or reposition the filter with the delivery catheter once the filter deployment has been initiated. If there is a need to change the position of filter, retrieve it using the retrieval catheter and use a new EmPro system.

9. Verify that the filter is fully expanded and opposed to the vessel wall by visually confirming markers.
10. Completely remove the delivery catheter by continuing to withdraw the delivery catheter until the catheter is completely peeled through the torque device. Be sure to minimize EPD system movement.

WARNING: A change in resistance may be felt when the Rapid exchange (Rx) port is peeled through the torque device. If the catheter begins to stretch or breaks while peeling, follow the steps below

1. Loosen the torque device and stabilize the EPD delivery capture wire
 2. Carefully remove the torque device and delivery catheter as one unit by sliding them over the delivery capture wire. Use caution to minimize EPD filter movement.
11. Loosen the torque device and remove from the capture delivery wire before using any interventional devices.

EmPro EPD Retrieval

1. Peel the pouch and remove the dispenser coil containing the retrieval catheter.
2. Fill a 5ml syringe with saline ensuring no air emboli remains in the syringe.
3. Insert distal tip of the retrieval catheter into the syringe tip and seal with fingers.
4. Inject saline until saline drips out of the Rapid exchange (Rx) exit port.
5. Load the retrieval catheter over the EPD delivery capture wire and advance until the distal marker reaches the EPD filter. See Figure below.

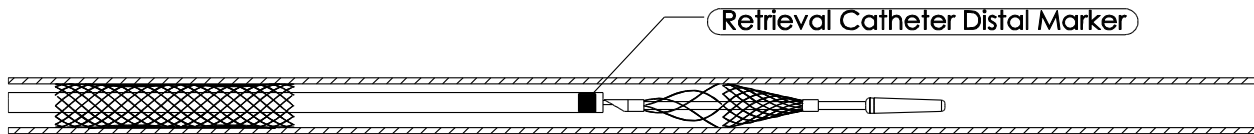

6. While maintaining position of the retrieval catheter, pull on EPD capture delivery wire to withdraw the filter into the retrieval catheter. Withdraw until the EPD filter is fully captured or resistance is felt. Complete retrieval of the filter is achieved when the filter marker has been withdrawn proximal to the radiopaque retrieval catheter tip and a stop or resistance is felt.
7. Remove both the EPD and retrieval catheter simultaneously out of the access guide catheter or introducer sheath.

If an exceptionally large amount of embolic debris within the filter element prevents complete withdrawal of the filter element into the retrieval catheter tip or resistance is felt, the following steps of retrieval must be taken to retrieve the filter element.

1. Hold the retrieval catheter position steady by gripping the shaft close to the RHV.
2. Pull on the EPD capture delivery wire and filter into the retrieval catheter tip until resistance is felt. The proximal openings of the filter element are fully contained with the catheter tip once the radiopaque markers on the filter frame have been withdrawn into the radiopaque retrieval catheter tip. **Do not continue to retract the capture delivery wire against significant resistance.**
3. Withdraw both the capture delivery wire and retrieval catheter as one unit.

Warning: If the EmPro device cannot be fully withdrawn as described above, the EmPro device must be removed with the guide catheter or introducer sheath.

4. Retract the retrieval catheter and embolic protection device as one unit until the tip of the retrieval catheter is adjacent to the tip of the guide catheter or introducer sheath.
5. Withdraw the guide catheter or introducer sheath, retrieval catheter, and embolic protection device together as one unit and remove from the patient.

CLINICAL DATA

The CONFIDENCE study (NCT02657707) was a multicenter, single-arm, interventional study designed to evaluate the safety and effectiveness of the CASPER Carotid Artery Stent used in conjunction with the EmPro EPS in patients at high risk for adverse events from carotid endarterectomy (CEA) who required carotid revascularization. All patients with qualifying carotid artery stenosis ($n = 274$) were treated with the devices. The primary endpoint was the Major Adverse Event (MAE) composite consisting of death, stroke, or MI within 30 days of the index procedure plus ipsilateral stroke between 31 days and 12 months. The secondary endpoints included procedure, stent technical success, EPD technical success, target lesion revascularization, in-stent restenosis, major or minor stroke within 30 days, transient ischemic attack within 30 days, and neurologic death.

The primary analysis was conducted on the Intent-To-Treat (ITT) population, which includes 256 subjects that had the CASPER Carotid Artery Stent implanted. The Complete Case (CC) population includes all ITT subjects completing the 12-month follow-up evaluation. In the ITT population ($N=256$), 15 patients (5.9% [95% exact binomial CI: 3.32, 9.48]; $p=0.0002$) experienced the composite endpoint of a CEC-adjudicated MAE. The upper limit of the

95% CI was <13.9%, therefore the primary endpoint was met. 18 additional subjects were added to the study, bringing the total to 274 treated subjects.

CEC-adjudicated Primary Endpoint	ITT Population N=256	CC Population N=244	Total Population N=274
Subjects who had an MAE*, n (%)	15 (5.9%)‡	15 (6.1%)‡	16 (5.8%)‡
95% exact binomial CI	(3.32, 9.48)	(3.48, 9.94)	(3.37, 9.31)
p-value†	0.0002	0.0005	0.0001
Subjects who died within 30 days of the index procedure	1 (0.4%)	1 (0.4%)	2 (0.7%)
Subjects who had a stroke within 30 days of the index procedure	7 (2.7%)	7 (2.9%)	7 (2.6%)
Subjects who had an MI within 30 days of the index procedure	1 (0.4%)	1 (0.4%)	1 (0.4%)
Subjects who had an ipsilateral stroke 31-365 days post-index procedure	7 (2.7%)	7 (2.9%)	7 (2.6%)
*MAE is defined as death, stroke, or MI within 30 days of the procedure plus ipsilateral stroke 31-365 days post-index procedure.			
‡ Two MAE events occurred in one subject.			
†Probability value derived from the 2-sided binomial test vs. an a priori Performance Goal of 13.9%.			

Secondary endpoints include technical success, procedure success, embolic protection device technical success, target lesion revascularization within 12 months of follow-up, and in-stent restenosis at 30-day and 12-month follow-up.

Endpoint	ITT Population N=256 (%)	CC Population N=244 (%)	Total Population N=274 (%)
Technical Success ^a	248 (96.9%)	236 (96.7%)	266 (97.1%)
Procedure Success ^b	243 (94.9%)	231 (94.7%)	261 (95.3%)
Embolic Protection Technical Success ^c	253 (98.8%)	241 (98.8%)	270 (98.5%)
Target Lesion Revascularization ^d	9 (3.5%)	9 (3.7%)	9 (3.3%)
In-stent Restenosis ^e at 30-day follow-up	5 (2.0%)	5 (2.0%)	6 (2.2%)
In-stent Restenosis at 12-month follow-up	14 (5.5%)	14 (5.7%)	16 (5.8%)
^a Successful deployment of CASPER in targeted treatment location with a residual diameter stenosis <50% immediately after post-dilatation as determined by the angiography Core Laboratory and with successful removal of delivery system.			
^b Successful CASPER implantation, <50% residual angiographic stenosis as determined by the angiography Core Laboratory by visual NASCET assessment immediately post procedure at the target lesion and no in- hospital (pre-discharge) MAE (stroke, MI or death)			

^cSuccessful delivery and deployment beyond the target lesion and successful retrieval after completion of the stent placement.

^dTLR was defined as any clinically driven revascularization procedure of the original treatment site associated with narrowing >80% within 12 months post-procedure, including angioplasty, stenting, endarterectomy, or thrombolysis, performed to open or increase the luminal diameter ≤5 mm of the previously treated lesion.

^eIn-stent Restenosis included subjects with >70% residual stenosis determined by ultrasound (PSV >300 cm/s and/or ICA/CCA PSV ratio >4.0) within the stented lesion.

EmPro EPS technical success was achieved in 98.8% (253/256) of subjects.

EmPro EPD Performance Analysis	ITT Population N=256 (%)	Total Population N=274 (%)
EPD successfully inserted	255 (99.6%)	273 (99.6%)
EPD successfully deployed in subject (Technical Success)	253 (98.8%)	270 (98.5%)
EPD successfully retrieved	255 (99.6%)	273 (99.6%)
Vessel dissection at EPD filter site	0	0

79.2% of patients experienced ≥1 Adverse Event (AE) within 1 year of the procedure. Most AEs were mild-to-moderate in severity. 38.3% of patients experienced ≥1 SAE (Serious Adverse Event) within 1 year of the procedure. The SAEs were categorized as shown in table below. The most common SAEs by System/Organ Class were Nervous System Disorders, Vascular Disorders, Cardiac Disorders, and Infections And Infestations. These accounted for 129 of the 210 (61.4%) SAEs. With respect to the EmPro EPS, only a single patient had an SAE. This SAE was a Nervous System Disorder (Cerebrovascular Accident).

System/Organ Class	ITT Population (N=256)	Total Population (N=274)
Blood And Lymphatic System Disorders	7 (2.7%)	7 (2.6%)
Cardiac Disorders	22 (8.6%)	23 (8.4%)
Congenital, Familial And Genetic Disorders	1 (0.4%)	1 (0.4%)
Eye Disorders	2 (0.8%)	2 (0.7%)
Gastrointestinal Disorders	8 (3.1%)	8 (2.9%)
General Disorders And Administration Site Conditions	8 (3.1%)	9 (3.3%)
Hepatobiliary Disorders	4 (1.6%)	4 (1.5%)
Infections And Infestations	19 (7.4%)	21 (7.7%)
Injury, Poisoning And Procedural Complications	5 (2.0%)	5 (1.8%)
Investigations	1 (0.4%)	1 (0.4%)
Metabolism And Nutrition Disorders	3 (1.2%)	3 (1.1%)
Musculoskeletal And Connective Tissue Disorders	2 (0.8%)	2 (0.7%)
Neoplasms Benign, Malignant And Unspecified (Incl Cysts And Polyps)	8 (3.1%)	8 (2.9%)
Nervous System Disorders	30 (11.7%)	31 (11.3%)
Psychiatric Disorders	2 (0.8%)	2 (0.7%)
Renal And Urinary Disorders	6 (2.3%)	6 (2.2%)

Respiratory, Thoracic And Mediastinal Disorders	15 (5.9%)	16 (5.8%)
Skin And Subcutaneous Tissue Disorders	1 (0.4%)	1 (0.4%)
Vascular Disorders	26 (10.2%)	26 (9.5%)

The findings from the CONFIDENCE study provide evidence that the treatment of carotid artery stenosis in patients with elevated risk for AEs after CEA with the use of the CASPER carotid artery stenting and the EmPro EPS is safe and effective. Together, these devices result in high rates of technical and procedural success, with low morbidity, mortality, in-stent restenosis, and target lesion revascularization. The benefits of treatment are clinically significant and outweigh the risks associated with their use.

HOW SUPPLIED

Sterile: This device is sterilized using Ethylene Oxide. Non-pyrogenic

Contents: One (1) MicroVention EmPro EPS

Storage: Keep dry and away from sunlight.



WARRANTY DISCLAIMER

MicroVention warrants that reasonable care has been used in the design and manufacture of this device. This warranty is in lieu of and excludes all other warranties not expressly set forth herein, whether expressed or implied by operation of law or otherwise, including, but not limited to, any implied warranties of merchantability or fitness for particular purpose. Handling, storage, cleaning, and sterilization of the device as well as factors relating to the patient, diagnosis, treatment, surgical procedure, and other matters beyond MicroVention's control directly affect the device and the results obtained from its use. MicroVention's obligation under this warranty is limited to the repair or replacement of this device through its expiration date, and MicroVention shall not be liable for any incidental or consequential loss, damage or expense directly or indirectly arising from the use of this device. MicroVention neither assumes, nor authorizes any other person to assume for it, any other or additional liability or responsibility in connection with this device. MicroVention assumes no liability with respect to devices reused, reprocessed or resterilized and makes no warranties, expressed or implied, including, but not limited to, merchantability or fitness for intended use, with respect to such device.

Prices, specifications, and model availability are subject to change without notice.

© Copyright 2025 MicroVention Corporation. All rights reserved.

MicroVention™, CASPER™, and EmPro™ are trademarks of MicroVention, Inc., registered in the United States and other jurisdictions.



Manufacturer:

MicroVention, Inc.

35 Enterprise

Aliso Viejo, CA 92656

Tel: 714.247.8000

www.terumoneuro.com

IFU100259 Rev. A
2025-04