

UNTHA

The reliable brand!



TOUGH in performing,
SMART in saving

2R CLASS

2-shaft shredder for the rough shredding
of high-volume waste and recyclables



Table of contents

ZR stationary	3
ZR mobil-e	8
ZR System solution	13
ZR Top benefits	16
ZR Technical data	22

ZR Class

Tough in performing, smart in saving

The high-performance ZR class is designed for the rough shredding of different materials and is exceptionally economical even in continuous operation under tough conditions. Pioneering technology results in an extremely low lifecycle costing for the operator, making the ZR a reliable powerhouse that pays for itself.



For more information
on performance, see
here:

The highlights

- » **Low energy costs:** Tangible savings thanks to UNTHA Eco Power Drive
- » **Highly versatile:** A single machine for a range of materials
- » **High degree of purity:** Cutting chamber is easy and quick to clean
- » **Efficient maintenance:** Cutting table and cutting shafts may be exchanged quickly
- » **Output particle precision:** Cutting shafts running independently of one another ensure perfect material breakdown
- » **Increased productivity:** Improves machine utilisation thanks to UNTHA GENIUS condition monitoring system
- » **Highly flexible:** Available as a stationary and mobile version

Suitable for

- » Domestic waste
- » Bulky waste
- » Commercial and industrial waste
- » Waste wood
- » Mattresses
- » Carpets
- » Building waste
- » Railway sleepers
- » Bales and rolled goods
- » Non-ferrous metal scrap
- » White goods
- » Electronic waste



ZR 2400W

ZR stationary

Your benefits at a glance

High level of user-friendliness

Machine is operated via a 7" colour touch display.

Energy-saving UNTHA Eco Power Drive

The energy-efficient electric drive with a water-cooled synchronous motor is a real economiser and uses up to 75 percent less energy than a standard diesel-hydraulic drive. The wear-free direct drive reduces maintenance costs as belts or shaft stubs are not required. The load-dependent speed control ensures a high throughput rate.



Highly maintenance-friendly

The cutting chamber of the ZR is easily accessible and easy and quick to clean.

Effective cutting systems

H and W cutting system for different requirements and materials. Cutting shafts and cutting table may be reconditioned and hard-surfaced, keeping operating costs low.

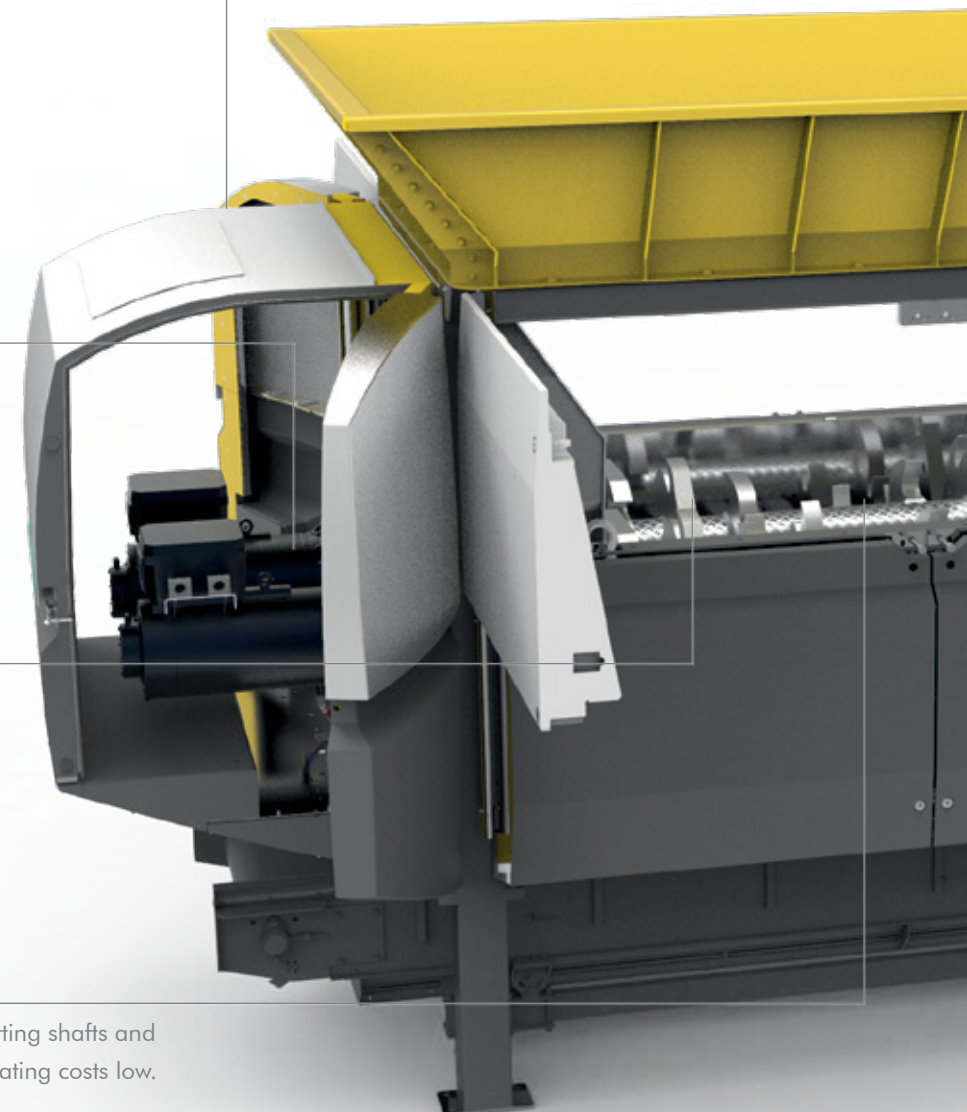

Robust feed hopper

3-sided hopper for loading with a wheel loader or 4-sided hopper for higher filling volumes and loading with material handlers or conveyors.

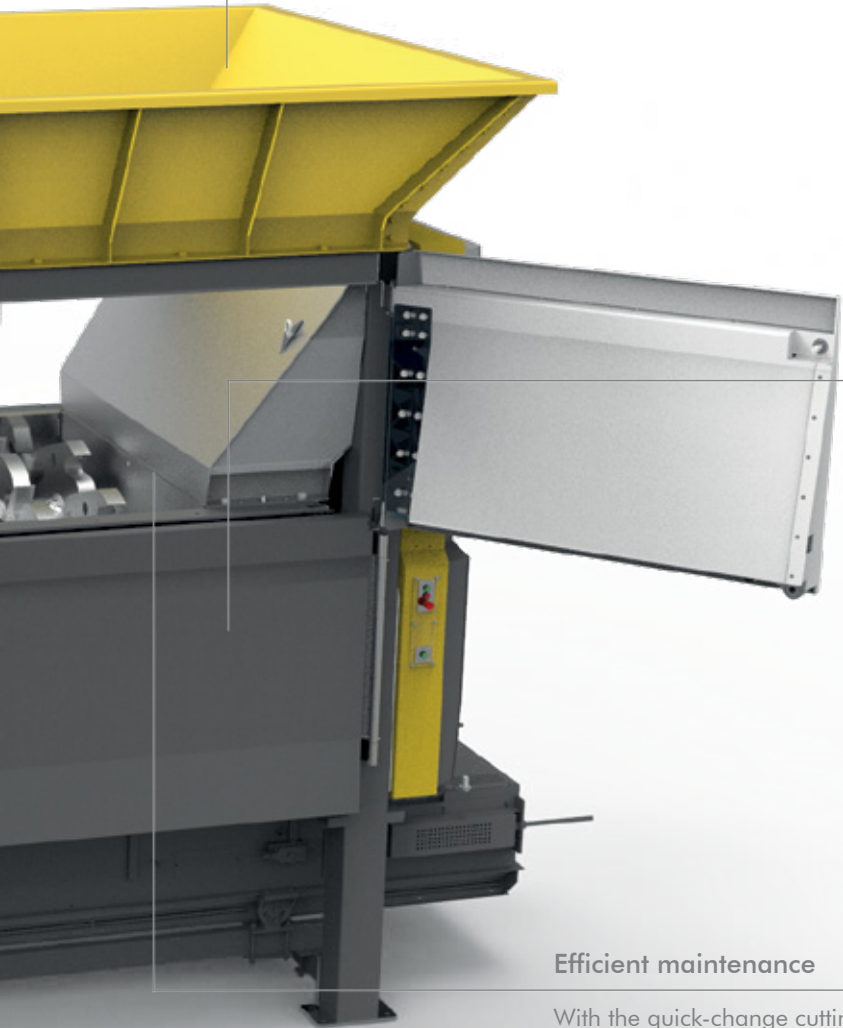

Output particle precision

Cutting shafts run independently of one another to ensure perfect material breakdown. The cutting shafts shred the material in both directions of rotation, ensuring a constantly high throughput.

Efficient maintenance

With the quick-change cutting system, the cutting table and the cutting shafts may be exchanged quickly, ensuring a high level of plant availability.



Options

Extras

- » **Safety coupling:** Protects the cutting system and the power train by means of a precise torque limit at higher speeds
- » **Radio remote control:** Hassle-free machine operation from different locations

Services

- » **UNTHA GENIUS:** The condition monitoring system for UNTHA shredders for the analysis and evaluation of all relevant machine data for increased productivity

The right cutting system for any requirement

Different materials require different cutting systems that are designed for application-specific requirements. With the H and the W cutting tables, users have two different cutting systems for a range of materials at their disposal. The powerful, slow-running 2-shaft technology is extremely resistant

H cutting system

The H cutting system is used for large throughputs and the rough shredding (90% < 300 mm) of high-volume waste that is difficult to process. The cutting table and the cutting shafts are quick and easy to exchange as a unit, thus increasing the availability of your machine. As an added bonus, the system is also easy to clean. The cutting shafts and the cutting table may be reconditioned and hard-surfaced, keeping operating costs low. The H cutting system is available both as a stationary and a mobile version.

Materials:

- » Domestic waste
- » Bulky waste
- » Commercial and industrial waste
- » Waste wood
- » Mattresses
- » Carpets
- » Building waste
- » Railway sleepers
- » Bales and rolled goods

towards-non-shreddables. Cutting shafts running independently of one another ensure perfect material breakdown. They shred the material in both directions of rotation, for a constantly high throughput. The robust, high-resistance machine design of the ZR class is designed for multi-shift,

continuous operation. The quick-change table system and the streamlined construction ensure a high level of plant availability. The cutting systems allow fraction-sizes of 90% < 300 mm. The final throughput depends on the type of material and ranges from 10 t/h to 100 t/h.

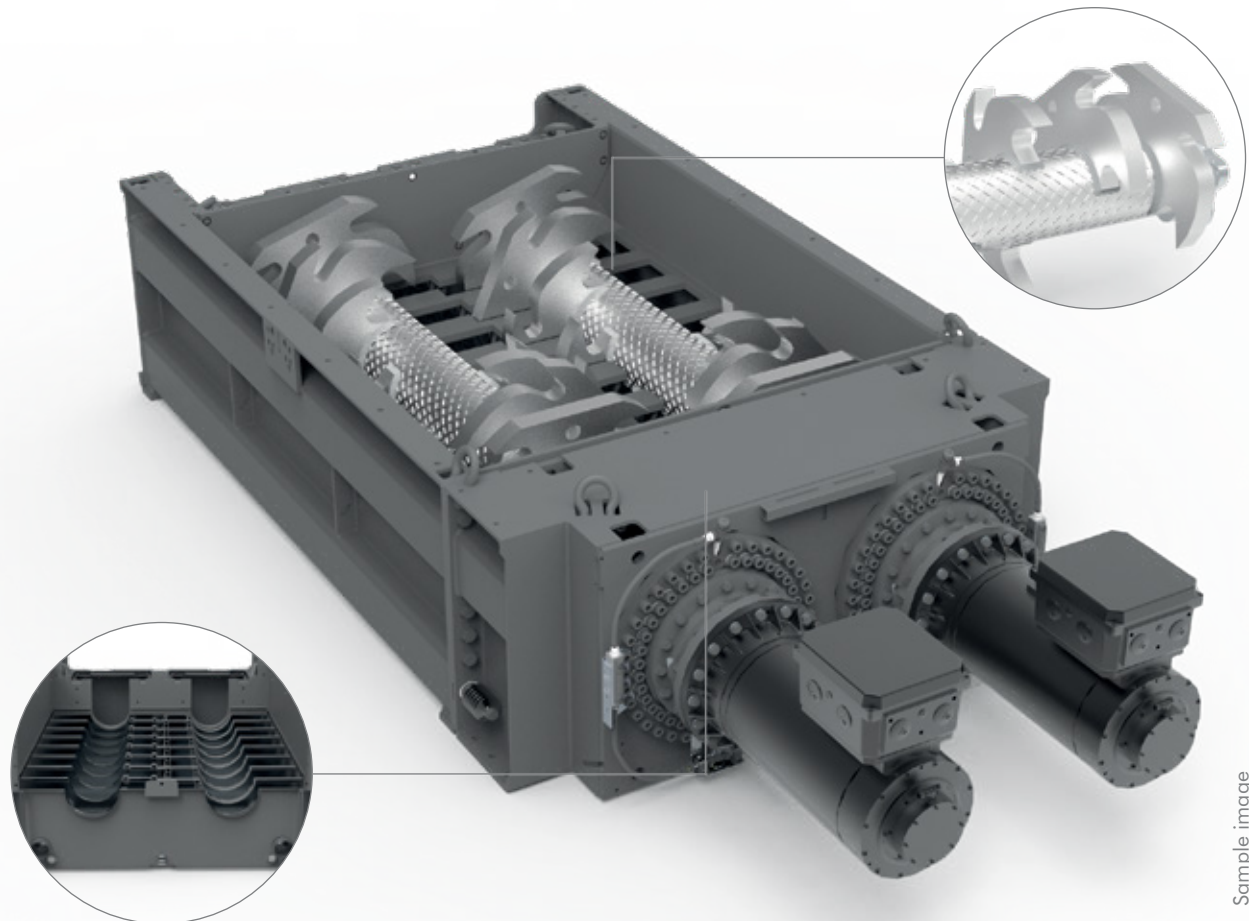

Sample image

W cutting system

The W cutting system is used for the shredding of non-ferrous metal scrap, white goods, and electronic waste. The goal is to achieve a rough material breakdown (90% < 300 mm) for downstream processes (sorting plant). The cutting table and the cutting shafts are quick and easy to exchange as a unit, thus increasing the availability of your machine. The cutting system is easy to clean, ensuring a high level of purity when it comes to changing the input material. The cutting shafts and the cutting table may be reconditioned and hard-surfaced, keeping operating costs low. The W cutting system is only available for the stationary version of the ZR class.

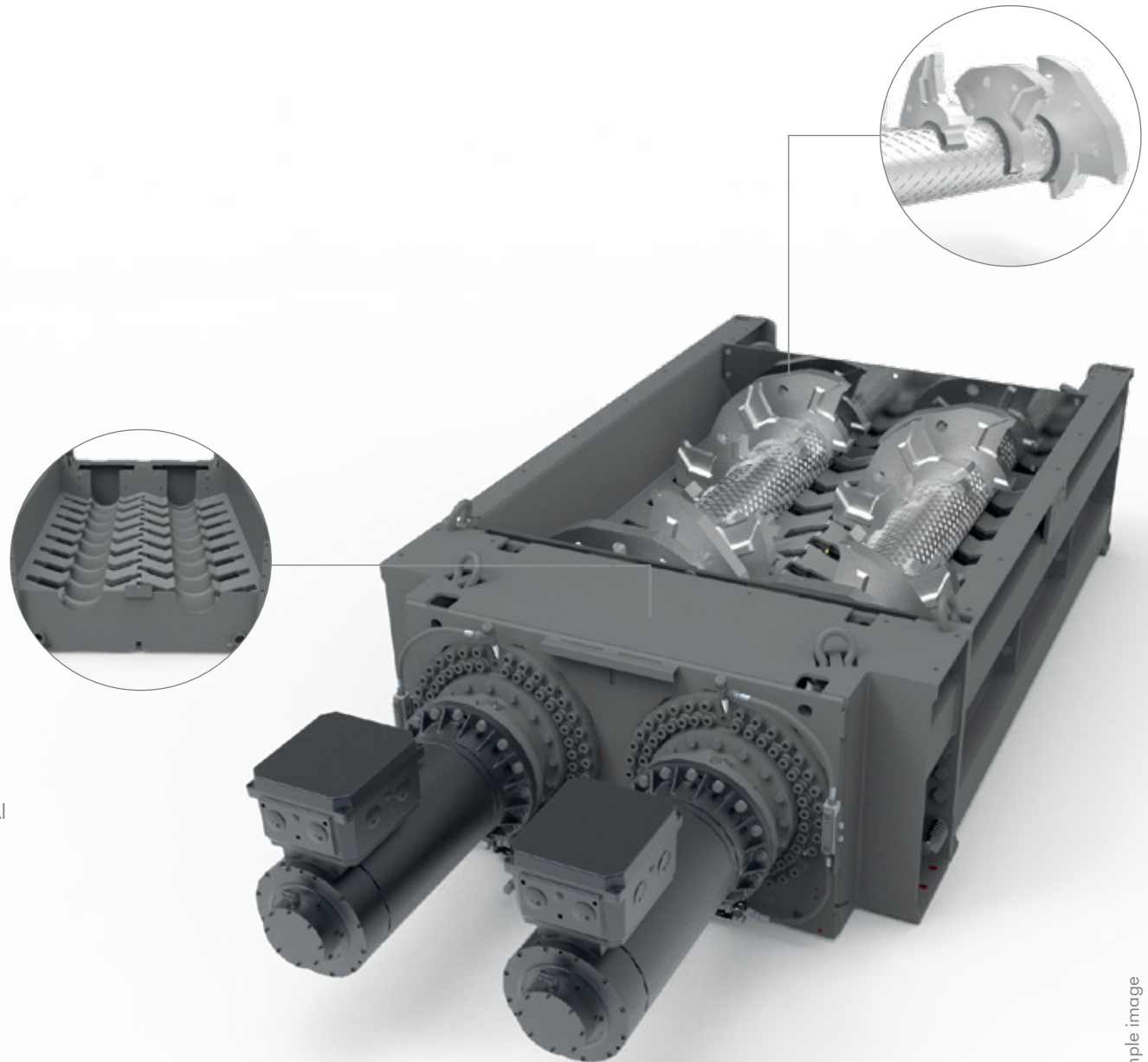

Materials:

- » Non-ferrous metal scrap
(Al-Cu coolers, Al mixed, Al profiles/Al wires/Al sheets, Al-ISO profiles, Al wheels)
- » White goods
(refrigerators, washing machines, freezers, cooling counters etc.)
- » Electronic waste





2R2400H

mobile

/// DANGER STAND CLEAR 10m ///

2R mobil-e

Your benefits at a glance

Effective water cooling system

Protects drive motors, frequency converters, hydraulic systems and control cabinets against overheating.



Highly user- and maintenance-friendly

Machine is operated via a 7" colour touch display. Thanks to the well thought-out machine design, operators are able to work comfortably, speedily and safely and in an upright position.



Quick-lock power plug

The machine may be connected easily and safely to the external power supply.

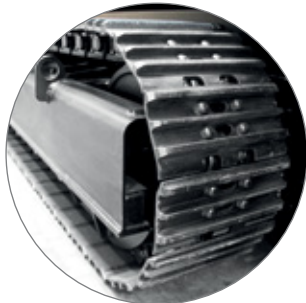

Reliable crawler-type undercarriage

A crawler-type undercarriage ensures that the shredder may be positioned at any location by means of a user-friendly radio control unit.



Energy-saving UNTHA Eco Power Drive

Drive system with water-cooled synchronous engine ensures unprecedented low energy use at higher performance compared to standard drive types. The wear-free direct drive reduces maintenance costs as belts or shaft stubs are not required. The load-dependent speed control ensures a high throughput rate.

Compact petrol and hydraulic power unit

A compact, energy-efficient petrol engine produces the required energy for the crawler-type undercarriage by means of a generator.

Tried-and-tested magnetic separator (optional)

A permanent overbelt magnet reliably separates ferrous metals materials from the material flow.



Height-adjustable discharge conveyor belt

A high-performance conveyor belt ensures the smooth removal of material. The discharge height may be adjusted easily via the operating terminal.

Options

Extras

- » Integrated fire suppression system
- » Additional flame detector for the feed hopper
- » Crawler-type undercarriage with rubber coating

Services

- » **UNTHA GENIUS:** The condition monitoring system for UNTHA shredders for the analysis and evaluation of all relevant machine data for increased productivity



Electro-mechanical drive and fully mobile

Like all the ZR products, the ZR2400 mobil-e also comes with the energy-efficient UNTHA Eco Power Drive. You can rest assured that your operating costs will be minimised and your throughput and material quality maximised. The highlight: As opposed to conventional diesel-operated, energy-consuming, environmentally damaging, noisy and high-maintenance mobile units, the ZR2400 mobil-e has an electric drive that is cost-effective and CO₂ neutral.

The combination of a crawler-type undercarriage and a small petrol engine ensures optimal mobility. Using a radio control unit, the ZR2400 mobil-e may be manoeuvred to any location and then re-connected to the power supply using a quick-lock power plug. A height-adjustable material conveyor belt and an optional magnetic separator offer you everything you need for the efficient operation of this mobile shredding system.

Your benefits at a glance:

- » Up to 75% lower energy costs compared to diesel-operated mobile units
- » No exhaust emissions
- » Flexibility in choosing a location for the unit on your premises
- » Low noise level
- » Low operating and maintenance costs
- » Remote maintenance
- » State-of-the-art, sustainable machine concept



UNTHA

2R2400H

⚠ DANGER STAND ⚠

2R System solution

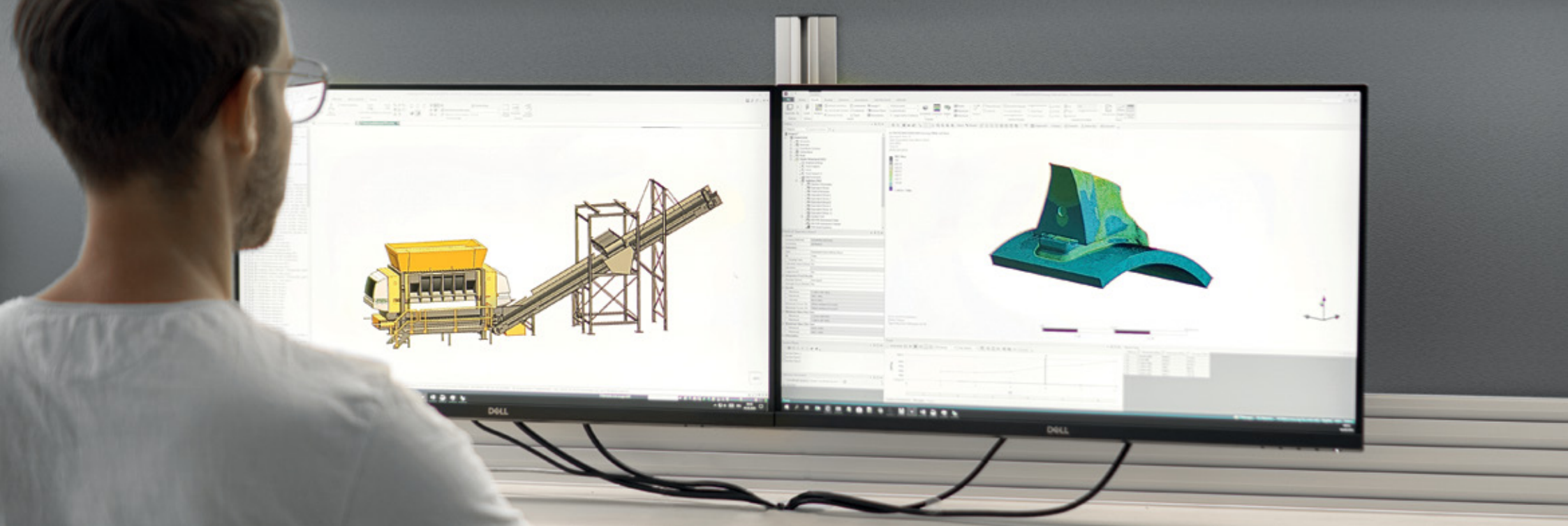

Complete turnkey solutions from a single source

UNTHA shredding technology offers complete turnkey solutions for single- and 2-phase shredding. Low investment, compact design and low operating and maintenance costs make this solution particularly attractive. It is also extremely versatile and can be used for the processing of industrial and commercial waste as well as metals, bulky waste or waste wood. High-quality individual components that are perfectly

coordinated ensure maximum availability of the overall system. The individual components and the shredder are easy and comfortable to operate via a central operating console. Highly competent project managers are at your disposal for reliable and efficient project completion. Our specialists will assist you all the way from the planning and project execution phase to the successful commissioning of your facility.

Your benefits at a glance:

- » Speedy, hassle-free installation of the complete solution on site
- » High level of availability thanks to the use of high-grade individual components
- » Easy operation of the complete system via a centralised operating console
- » Easy to integrate in existing plant concepts

System solution, including components, at a glance



Fire extinguishing system



Discharge conveyor system

Magnetic separator



Technology room



2R Top benefits



UNTHA Eco Power Drive

More performance, hard-wearing, and yet economical: That's the UNTHA Eco Power Drive in a nutshell, and that's what makes it one of the most powerful and efficient drive systems in the world.

Innovative

This highly efficient direct drive consists of high-torque synchronous motors and a planetary gear that is integrated in the rotor. No other drive concept offers this much power and throughput when it comes to shredding. In addition, the system is resistant towards extraneous matter and extremely quiet.

Powerful

Power by name, power by nature. The load-dependent speed control ensures the continuous, automatic adjustment of torque and speed, ensuring high throughput rates for a wide range of different materials.

Economical

The high efficiency level of the water-cooled drive motors translates into tangible savings: With the UNTHA Eco Power Drive, energy costs are up to 75% lower than with conventional hydraulic drive concepts. The wear-free direct drive reduces maintenance costs as belts or shaft stubs are not required. It goes without saying that the UNTHA Eco Power Drive fulfils the requirements of the highest energy efficiency class IE4 (Super Premium Efficiency).

Flexible

Depending on the material requirements, the drive may be designed for combination with different gear ratios: low gear ratio for tough applications, high gear ratio for high throughput rates with light materials. As an additional protection mechanism against damage from extraneous matter, a low-maintenance safety coupling that runs in an oil bath is an option.

Your benefits at a glance:

- » High-performance direct drive for a high throughput
- » Resistant towards extraneous matter
- » High energy efficiency
- » Low energy
- » Low noise emission



UNTHA cutting chamber quick-change system

The cutting table and the cutting shafts of the ZR class constitute a single unit, making the cutting system particularly easy to exchange. Thanks to the UNTHA quick-change cutting system, both the H and the W cutting tables of the ZR may be rapidly removed and replaced with a new unit. This reduces machine downtime to a minimum and increases plant availability at the same time.

High availability

While the cutting system that has been removed from the unit is maintained, reconditioned and hard-surfaced in the workshop, the shredder continues to run at full capacity thanks to the replacement cutting system. If you keep a second cutting system at hand, your shredder will continue to run as normal, thus considerably lowering your maintenance and servicing costs.

Maximum flexibility

Thanks to the quick-change cutting system, it is not just possible to resume normal operation within a very short period of time: As there are two different cutting systems available for the ZR shredder, you may switch to the other system as required, thus significantly increasing flexibility with regard to the material to be shredded.



UNTHA GENIUS: Your shredder's brain

Maximise the productivity of your plant

UNTHA GENIUS is an intelligent condition monitoring tool for UNTHA shredders. With the help of reliable sensor technology, the operation of your machine is monitored on an ongoing basis. GENIUS processes all your data in real-time, alerts you of any deviations and sends decision support directly to your smartphone, tablet or PC. With UNTHA GENIUS, you always have a complete over-

view of your entire UNTHA machine pool. Make the most of this information via an at-a-glance dashboard of real-time data, to see if your production is running smoothly. The goal of UNTHA GENIUS is clear: To help you maximise the availability and performance of your machine while minimising maintenance and downtime costs. But UNTHA GENIUS is much more than a standard monitoring tool - it is also a fantastic analysis tool. Thanks to the long-term storage of process data, it is possible to analyse trends that will constitute an ideal basis for

optimisation in order to increase the cost-effectiveness of your plant on a lasting basis. UNTHA GENIUS may be used with all UNTHA industrial shredders.



UNTHA GENIUS
in a nutshell:



Reliability throughout the lifetime of your unit

UNTHA Service Competence Center

UNTHA shredders are in operation all over the world and are appreciated for their longevity and reliability. And if there is an unplanned machine shutdown or unexpected challenges occur, our service experts are quick to help.

With the UNTHA Service Competence Center, we assist you throughout the entire product lifecycle and offer you comprehensive service products to maximise the availability of your machine. From regular maintenance and the provision of replace-

ment and wear parts to our individual Carefree Packages - we ensure that UNTHA machines are ready for use at all times and do what they were built for: the reliable shredding of material.



Put us to the test!

No challenge is too big for our ZR shredders:

- » Domestic waste
- » Bulky waste
- » Commercial and industrial waste
- » Non-ferrous metal scrap
- » White goods
- » Electronic waste
- » And much more.

See our units live in action at your premises or visit one of our reference customers. Book your live demonstration now at www.untha.com/en/zr-trial

ZR stationary

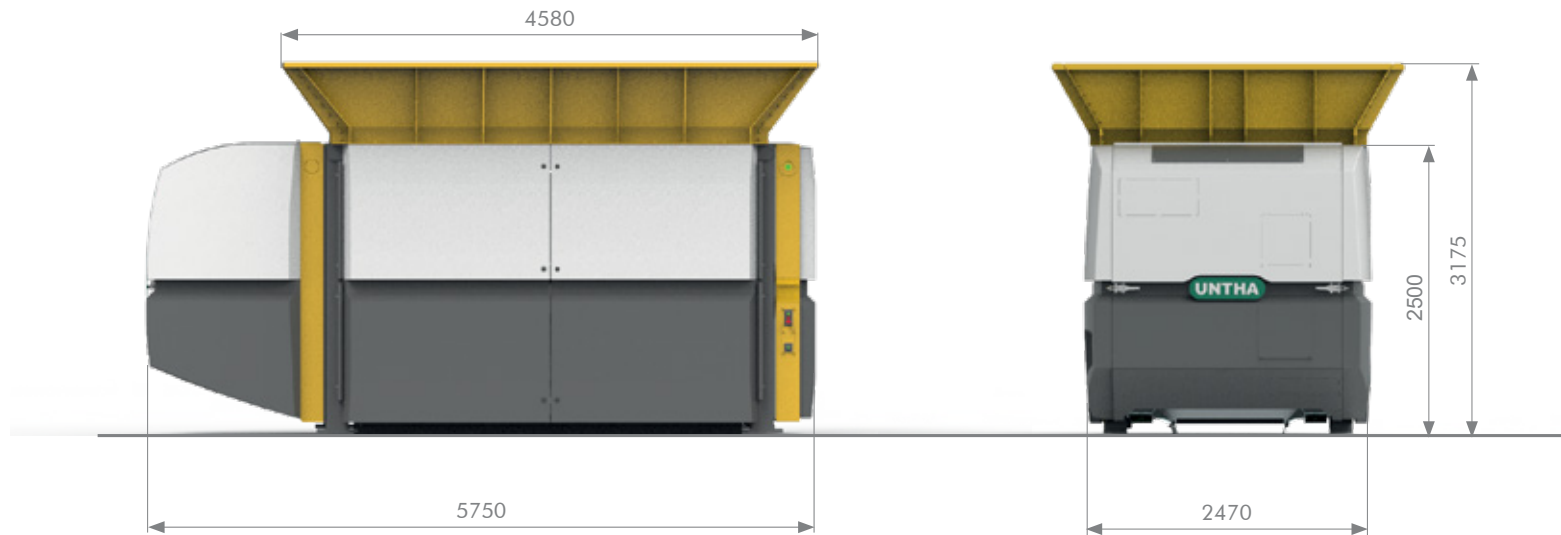

All dimensions in mm

TECHNICAL DATA		ZR2400	ZR2400 mobil-e
Drive type		UNTHA Eco Power Drive	
Rated capacity	kW	2 x 132	
Cutting shafts	Units	2	
Rotor length	mm	2380	
Rotor diameter	mm	900	
Number of blades	Units	16	
Rotor speed	rpm	Up to 55	
Dimensions (L/W/H)	mm	5750 x 2470 x 3175	11900 x 2900 x 4175
Total machine weight (excluding hopper)	t	~19	~39
Cutting system weight	t	12	12

2R mobil·e

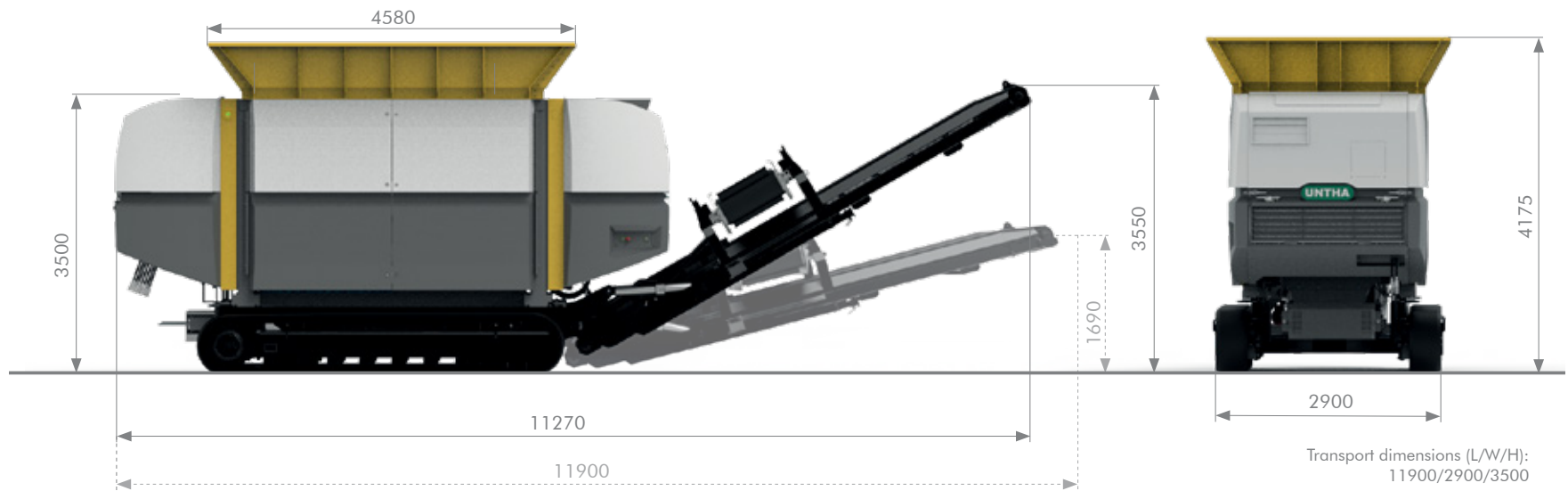

2R System solution

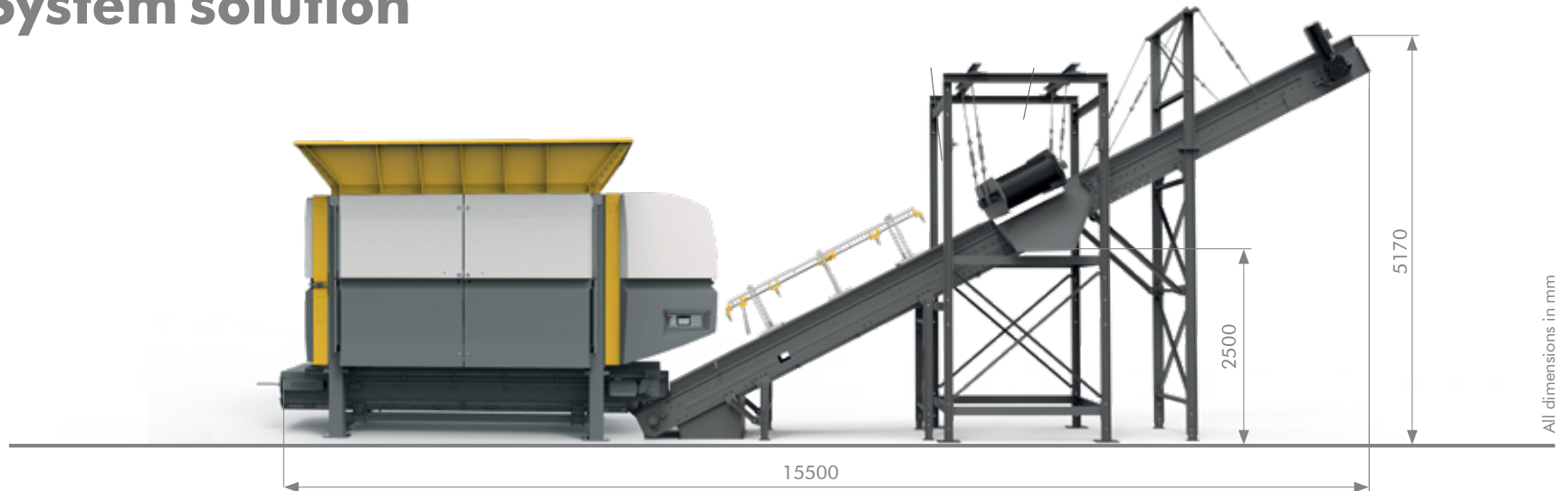

All dimensions in mm

UNTHA shredding technology GmbH

Kellau 141
5431 Kuchl | Österreich
Tel.: +43 6244 7016 0
Fax: +43 6244 7016 1
info@untha.com
www.untha.com

UNTHA Deutschland GmbH

Am Hammersteig 5a
97753 Karlstadt | Deutschland
Tel.: +49 9353 906869-0
Fax: +49 9353 906869-35
info@untha.de
www.untha.de

UNTHA UK Ltd.

Excel House, Becklands Close
Boroughbridge
YO51 9NR | United Kingdom
Tel.: +44 330 056 4455
sales@untha.co.uk
www.untha.co.uk

UNTHA America, Inc.

1 Lafayette Road, Building 4
Hampton, NH 03842 | USA
Tel.: +1 603 601 2304
Fax: +1 603 601 7573
info@untha-america.com
www.untha-america.com

UNTHA Polska Sp. z o.o.

Olecka 23/221
04-980 Warszawa | Polska
Tel.: +48 12 6421896
info@untha.pl
www.untha.pl

UNTHA Ibérica S.A.

Lugar Queirúa, s/n 15680 Ordes
La Coruña | España
Tel.: +34 981 69 10 54
Fax: +34 981 69 08 78
info@untha-iberica.com
www.untha.es

UNTHA Makina Sanayi ve Ticaret Limited Şirketi

Barbaros Mah. Kardelen Sok.
Palladium Tower No:2/114 K:32
34746 Ataşehir | İstanbul | Türkiye
Tel.: +90 216 687 2991
info.tuerkiye@untha.com
www.untha.com

5 reasons to choose UNTHA



Customised, long-lasting shredding solutions



Premium quality products and services



All-encompassing expertise, from development to production, under one roof



Reliable customer service with the best technical know-how



More than 10,000 satisfied reference customers worldwide

We deliver what we promise

Since our founding in 1970, we've followed our promise of being "the reliable brand", which applies to every product and service that UNTHA delivers.

We work hard to consistently outperform our competitors, and provide customers with the confidence that – in choosing UNTHA – they have made the best decision for their business.

All revisions reserved. Subject to setting and printing errors.
All illustrations are representative and may deviate from the actual product.
© 09/21 UNTHA shredding technology