

UNTHA

The reliable brand!



The first choice when it comes
to shredding waste wood

Shredding solutions for economic
processing of waste wood



The **1st choice** when it comes to shredding waste wood

Reliable, robust and enduring: everything a wood shredder should be. UNTHA is the specialist for customised shredders that are tailor-made to fulfil the requirements of woodworking and timber-processing businesses.

For 50 years, UNTHA has stayed true to its principle of being “the reliable brand”. This expertise makes UNTHA the uncontested first choice when it comes to shredding residual wood, for small workshops and occasional operation as well as for large-scale players in the timber industry. UNTHA has the right

shredder for every application! As UNTHA has a high percentage of in-house production directly at the Kuchl plant, the company is in a position to implement tailor-made solutions that reflect individual circumstances and requirements. From planning to project execution and commissioning with all the required peripheral devices, UNTHA offers its customers a one-stop-shop service.

The CE marking of all UNTHA machines guarantees a clearly defined framework for the handover based on EU standards, making the process easier and re-

ducing complexity. UNTHA products stand out for their longevity. In fact, UNTHA is the only manufacturer to offer a 3-year warranty on all its wood shredders, thereby demonstrating the reliability of its machines.



Utilise **the energy** that is hidden in your waste wood

Whether it's residual hardwood or veneers - our reliable shredders make sure that your waste wood is shredded efficiently and economically. They produce homogeneous, recoverable wood chips that are ideal for briquetting or thermal recovery.

Utilisation possibilities for residual wood

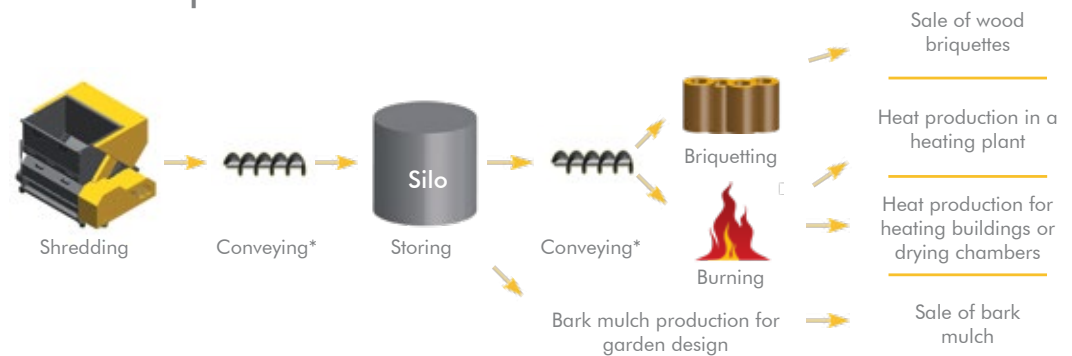

*) Conveying by screw conveyor, conveyor belt, drag chain conveyor, suction system, etc.

The tried-and-tested UNTHA cutting systems

Single-shaft cutting system:

The single-shaft cutting system was developed for efficient shredding, a long service life of the indexable inserts and low maintenance. Together with the high-performance power train, it ensures the reliable shredding of residual wood, both with and without a pusher system.

Smooth rotor shape

The smooth, full-steel rotor enables the indexable inserts to dig deeper into the material than a highly profiled rotor, resulting in excellent material feed-in.

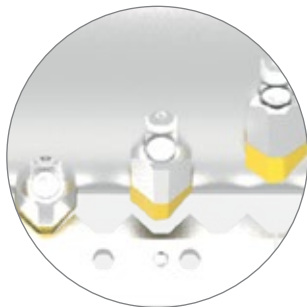

Low-wear main cutting bar

The reversible main cutting bar (from LR700) lowers maintenance costs.

Cut-as-you-pull

The unique shape of the indexable inserts makes for a "cut-as-you-pull" effect, which means that the unit requires less power and achieves a higher throughput.

Screwed-in blade holders

The screwed-in, exchangeable blade holders are easy and quick to replace in case of damage (for instance caused by solid metal parts).

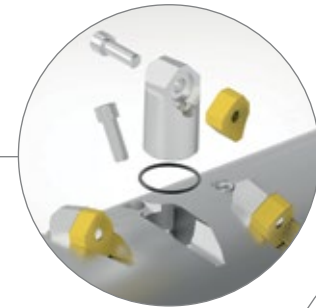

Reusable indexable inserts

Each side has a long lifespan, making the cutting system particularly low maintenance. The flat shape of the blade ensures a higher throughput, reduces wear and tear and is not susceptible to non-shreddables made of metal.

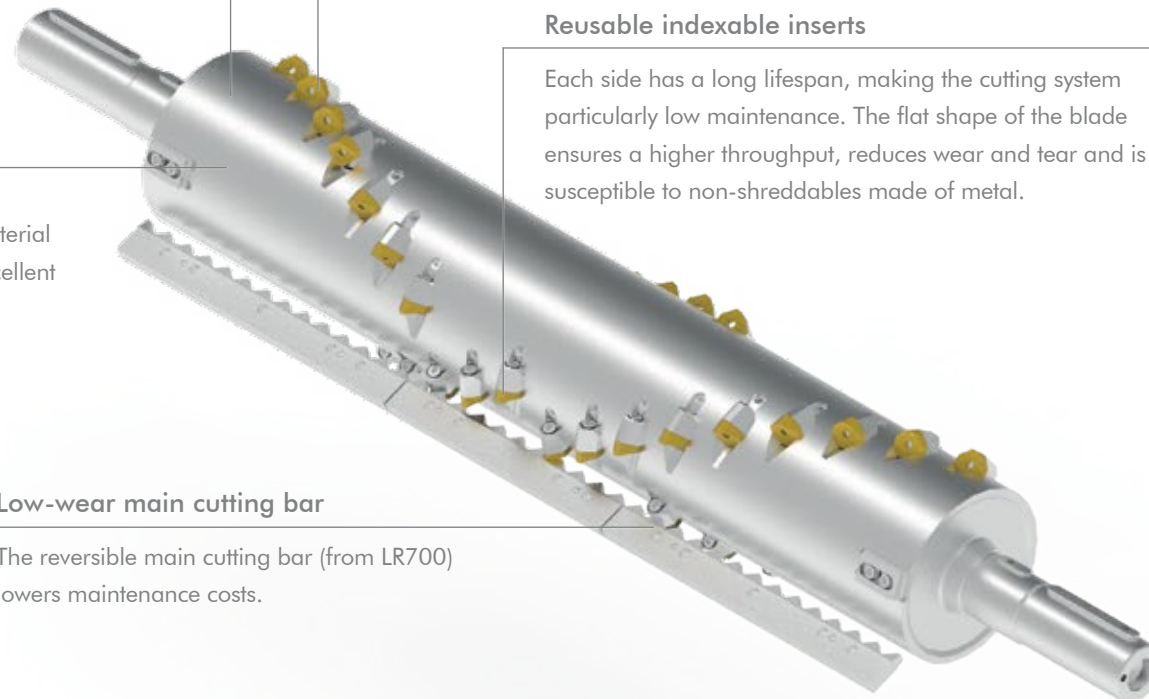
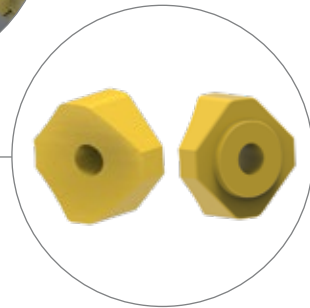



4-shaft cutting system:

The tried-and-tested, patented 4-shaft cutting system was developed specifically for tough challenges. The chopping discs are unsusceptible to non-shreddables, designed for intense, continuous operation and particularly economical due to their long service life.

Individually adaptable

The cutting system may be customised to suit the input material.

Slow-running cutting system

The cutting system is particularly resistant towards metal non-shreddables and stands out for its low dust and noise production.

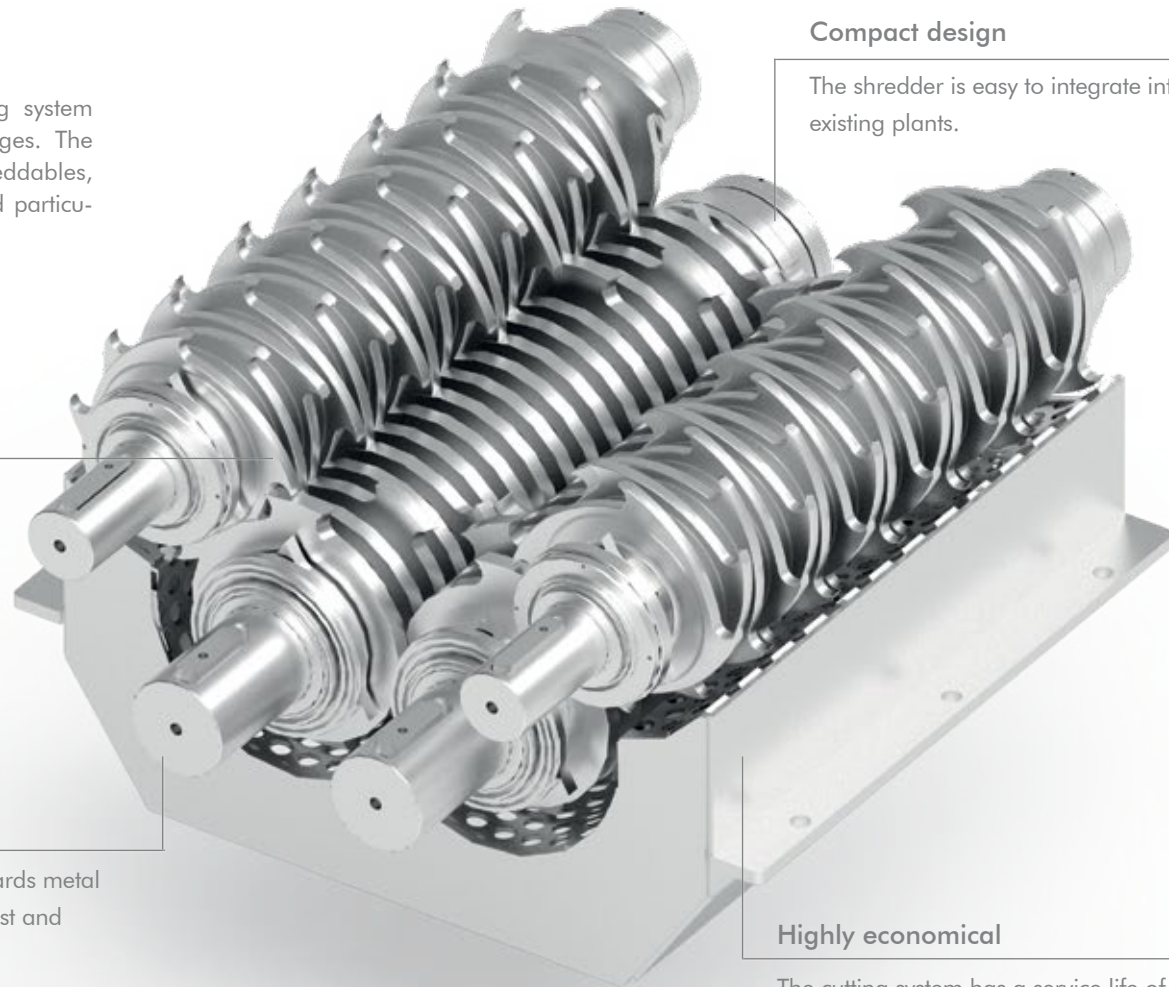

Compact design

The shredder is easy to integrate into existing plants.

Highly economical

The cutting system has a service life of several thousand hours.

The **optimal solution** for every application

There are several shredding systems available, depending on the application, the volume of waste wood and the installation conditions.

Single-shaft shredding system with horizontal pusher

During the shredding process, the hydraulically operated, horizontal pusher pushes the material against the rotor, which is fitted with exchangeable indexable inserts (load-dependent). The rotor shreds the material against the cutting bars and the perforated screen.



Single-shaft shredding system without pusher system

Thanks to the specially developed hopper and cutting chamber geometry, the material is pulled in independently by the rotor and shredded against the cutting bar and the perforated screen.

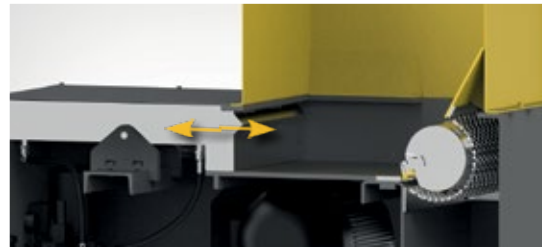

Single-shaft shredding system with swivelling pusher

During the shredding process, the hydraulically operated swivelling pusher pushes the material against the rotor which is fitted with exchangeable indexable inserts (load-dependent). The rotor shreds the material against the cutting bars and the perforated screen.



4-shaft shredding system

The material to be shredded is pre- and post-shredded in a single step after being fed into the cutting system (main cutting system).

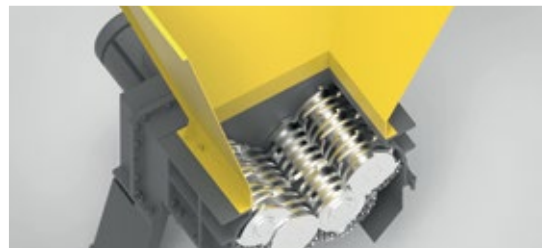

Product overview and areas of use



LR520

Single-shaft shredding system

Small wood-processing operations

hard and soft wood, OSB, chipboard panels, MDF board, veneers

COMPACT AND RELIABLE



LR700

Single-shaft shredding system

For carpentry shops and joiners

» hard and soft wood, OSB, chipboard panels, MDF board, veneers, cap pieces

COMPACT AND SUITABLE FOR UNIVERSAL USE



RS30/RS40

4-shaft shredding system

For the woodworking and timber-processing industry

» predominantly solid wood pieces from the production line

For carpentry workshops

» predominantly solid wood

DURABLE SOLID WOOD SHREDDER FOR INTENSIVE CONTINUOUS OPERATION



LR630

Single-shaft shredding system

For carpentry workshops

» hard and soft wood, OSB, chipboard panels, MDF board, veneers

SMALL PRICE, BIG PERFORMANCE



LR1000/LR1400

Single-shaft shredding system

For the woodworking and timber-processing industry

» hard and soft wood, OSB, chipboard panels, MDF board, veneers, cap pieces, pallets

For sawmills

» cap pieces of 0.9 – 1.3 m in length

HIGH PERFORMANCE FOR HIGH THROUGHPUTS

LR520

Single-shaft shredding system

COMPACT AND RELIABLE

Powerful technology, combined with the tried-and-tested UNTHA quality standards, make the LR520 not just the most reliable wood shredder in its class, but also one of the most affordable.

The LR520 is a single-shaft shredder that was developed especially for small wood-processing operations. Thanks to its unique, pusher-free construction, it requires very little space and is extremely low-maintenance.

The powerful drive concept, combined with the tried-and-tested UNTHA cutting system, ensures a highly reliable shredding process. The LR520 effortlessly shreds all kinds of residual wood, panels and long splinters. The homogeneous final product is extremely well suited for use in a wood-chip heating system or for manufacturing wood briquettes.

A low rated capacity and automatic shut-off in case of idling considerably reduce energy costs.

Areas of application

- » Hard and soft wood
- » OSB
- » Chipboard panels
- » MDF panels
- » Veneers
- » etc.



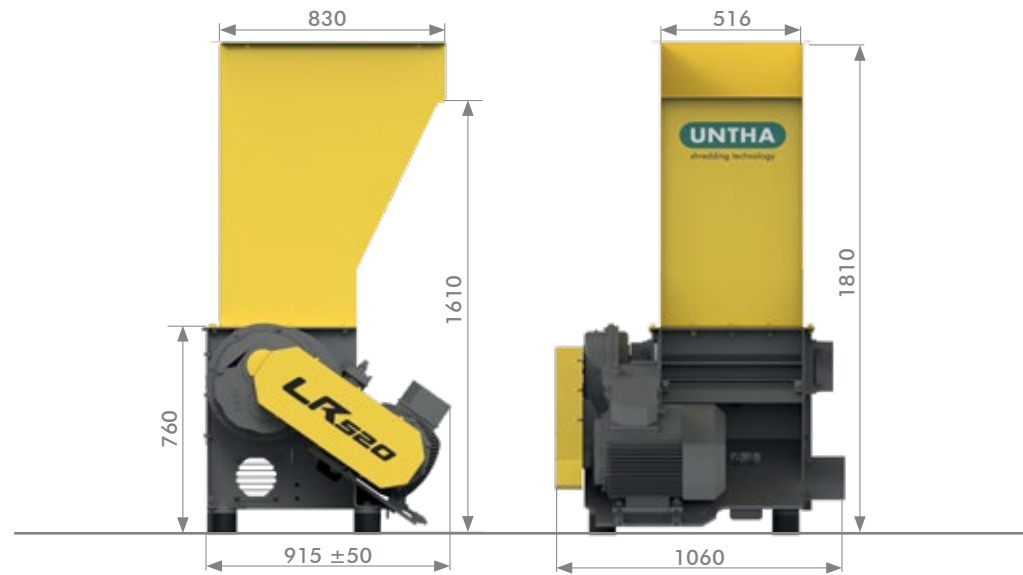

| TECHNICAL DATA | | LR520 |
|--|--------|-------------|
| Rated capacity | kW | 1 x 11 |
| Ø Rotor | mm | 248 |
| Rotor speed | rpm | 85 |
| Number of indexable inserts | pcs. | 14 |
| Feed opening | mm | 516 x 830 |
| Ø Suction nozzles | mm | 160 |
| Required suction speed | m/s | 22 |
| Weight | kg | approx. 650 |
| Workspace-specific sound pressure level LPA 1m | dB (A) | 82 |
| Ø Perforated screen | mm | 12 - 30 |
| Throughput rates* | srn/h | Up to 1 |

*) Dependent on type of material and diameter of perforated screen
All dimensions in mm

Your benefits at a glance



Reliable, cost-effective cutting system

The large rotor diameter (248 mm) and screen surface ensure a high throughput.

The screwed-in, exchangeable blade holders are easy and quick to replace in case of damage (for instance caused by solid metal parts). The precise cutting gap between the cutting bar and the indexable inserts makes the shredding process particularly efficient.

Unique geometry of the indexable inserts

The reusable indexable inserts have a long service life. Their unique cutting geometry ensures a “cut-as-you-pull” effect that makes for particularly effective shredding even of wet wood.

The positive connection between the indexable insert and the blade holders prevents the fastening bolt from becoming deformed. It is easy to loosen and remove even after many hours of operation.



Low-wear perforated screen

Depending on the requirements, a range of screens ensure the production of pre-defined wood chips. The shredded material is then removed via a suction mechanism or a screw conveyor.

The special design of the perforated screen provides a particularly homogeneous final product that is ideal for briquetting or use in a wood-chip heating system.





Pusher-free design

The pusher-free design (hopper and cutting system) makes this unit highly compact and space-saving (footprint of < 1 m²). The shredder is also particularly low in maintenance.

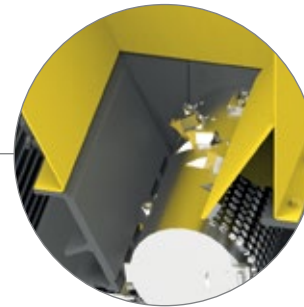

Unique warranty

As a proof of our excellent product quality, we are happy to offer you a 3-year warranty*. Many renowned companies already put their trust in our quality standards.

*3 years or 2000 hours, depending on which value is reached first.



Energy-efficient, failure-free drive concept

The tried-and-tested belt drive and elastomer damper absorb shocks and vibrations and ensure the smooth running of the machine. The automatic reverse function, detection of non-shreddables and shut-off function protect the drive unit. The automatic shut-off function shuts down the machine when idling, further lowering energy costs.

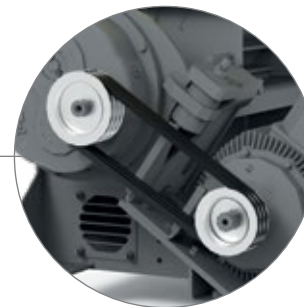

Options

Mechanical extras

- » Screw conveyor

Electrical extras

- » Control system upgrade (light barrier)
- » Integration of peripheral devices into the control system
- » Suction mechanism activation
- » Automatic start

Accessories

- » Customer-specific undercarriages
- » Range of discharge feed systems (conveyor belts, etc.)
- » Range of metal separation units

Service

- » UNTHA Carefree Packages (Basic, Standard, Professional): Ensure that machines are technically sound and ready for use at all times.

LR630

Single-shaft shredding system

SMALL PRICE AND GREAT PERFORMANCE

The LR630 is an absolute classic among single-shaft shredders, offering a robust design and excellent value for money. It is mostly used by carpentry and joinery workshops that have small to medium-sized volumes of residual wood.

The high-performance drive concept, a powerful horizontal pusher and the tried-and-tested UNTHA cutting system make for a highly reliable shredding process. The homogeneous final product is extremely well suited for use in a wood-chip heating system or for manufacturing wood briquettes.

A low rated capacity and automatic shut-off in case of idling considerably reduce energy costs.

Areas of application

- » Hard and soft wood
- » OSB
- » Chipboard panels
- » MDF panels
- » Veneers
- » etc.



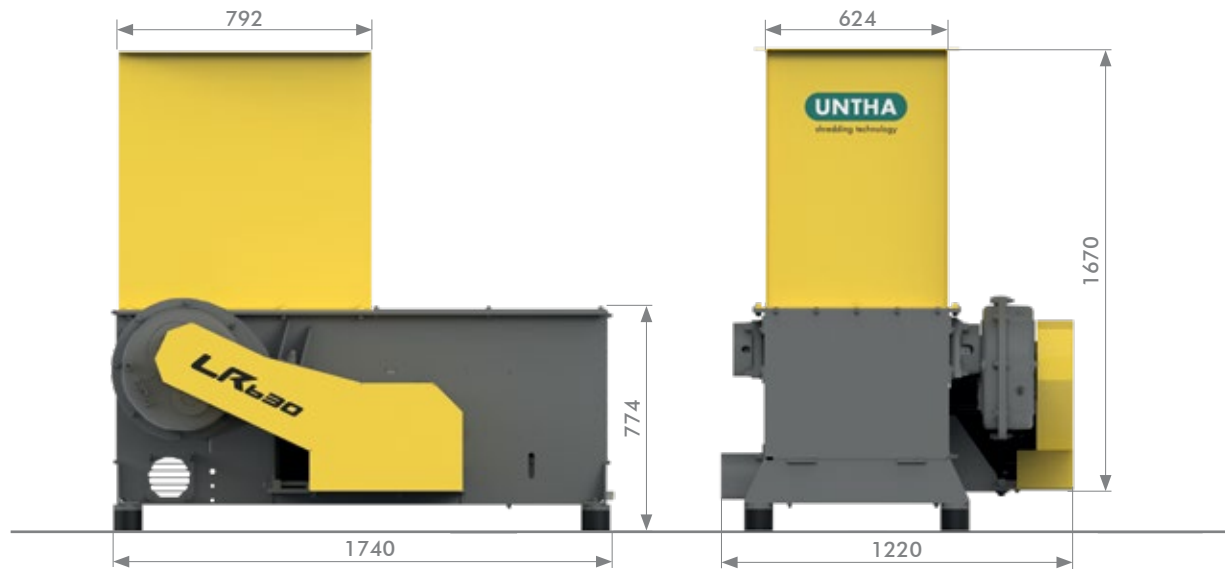

| TECHNICAL DATA | | LR630 |
|--|--------|---------------|
| Rated capacity | kW | 11/15/18.5 |
| Rated capacity of the hydraulic system | kW | 0.75 |
| Ø Rotor | mm | 248 |
| Rotor speed | rpm | 85 - 98 |
| Number of indexable inserts | pcs. | 17 |
| Feed opening | mm | 624 x 792 |
| Ø Suction nozzles | mm | 160 |
| Required suction speed | m/s | 28 |
| Weight | kg | approx. 1,300 |
| Workspace-specific sound pressure level LPA 1m | dB (A) | 82 |
| Ø perforated screen | mm | 15 - 30 |
| Throughput rates* | srm/h | Up to 2 |

*) Dependent on type of material and diameter of perforated screen
All dimensions in mm

Your benefits at a glance



Reliable, cost-effective cutting system

The large rotor diameter (248 mm) and screen surface ensure a high throughput.

The screw-in, exchangeable blade holders are easy and quick to replace in case of damage (for instance caused by solid metal parts). The precise cutting gap between the cutting bar and the indexable inserts makes the shredding process particularly efficient.

Unique geometry of the indexable inserts

The reusable indexable inserts have a long service life. Their unique cutting geometry ensures a “cut-as-you-pull” effect that makes for particularly effective shredding even of wet wood.

The positive connection between the indexable insert and the blade holders prevents the fastening bolt from becoming deformed. It is easy to loosen and remove even after many hours of operation.



Low-wear perforated screen

Depending on the requirements, a range of screens ensure the production of pre-defined wood chips. The shredded material is then removed via a suction mechanism or a screw conveyor.

The special design of the perforated screen provides a particularly homogeneous final product without excess lengths that is ideal for briquetting or use in a wood-chip heating system.

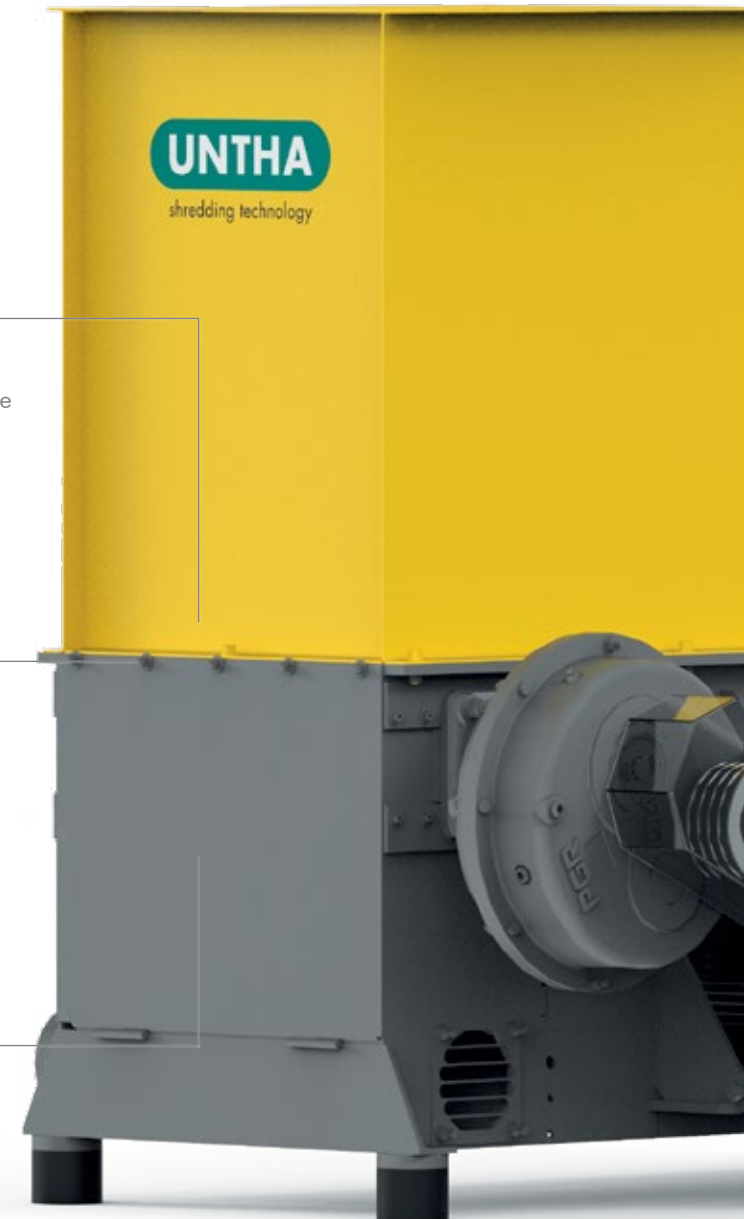

Unique warranty

As a proof of our excellent product quality, we are happy to offer you a 3-year warranty*. Many renowned companies already put their trust in our quality standards.

*3 years or 2000 hours, depending on which value is reached first.



Powerful pusher system

The powerful horizontal pusher pushes the residual wood against the rotor (load-dependent), ensuring a constant material feed. The hydraulic power unit is safely integrated in the machine frame and yet easily accessible.

Energy-efficient, failure-free drive concept

The tried-and-tested belt drive and elastomer damper absorb shocks and vibrations and ensure the smooth running of the machine. The automatic reverse function, detection of non-shreddables and shut-off function protect the drive unit. The automatic shut-off function shuts down the machine when idling, further lowering energy costs.

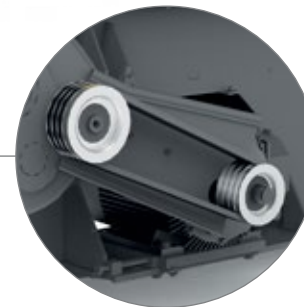

Options

Mechanical extras

- » Screw conveyor

Electrical extras

- » Control system upgrade (light barrier)
- » Integration of peripheral devices into the control system
- » Suction mechanism activation
- » Automatic start

Accessories

- » Customer-specific undercarriages
- » Range of discharge feed systems (conveyor belts, ...)
- » Range of metal separation units

Service

- » UNTHA Carefree Packages (Basic, Standard, Professional): Ensure that machines are technically sound and ready for use at all times

LR700

Single-shaft shredding system

COMPACT AND UNIVERSALLY APPLICABLE

The LR700 is a single-shaft shredder that was designed for a broad range of applications. Customers appreciate its compact design and universal application opportunities. The tried-and-tested UNTHA cutting system and the powerful, wear-free swivelling pusher ensure the reliable shredding of different types and volumes of wood.

The robust machine frame and high-grade components have a particular long service life. Thanks to the compact design, the machine only has a small footprint.

The powerful drive system and the high speed of the pusher ensure a high throughput. The homogeneous final product is extremely well suited for use in a wood-chip heating system or for manufacturing wood briquettes.

Areas of application

- » Hard and soft wood
- » OSB
- » Chipboard panels
- » MDF panels
- » Veneers
- » Cap pieces
- » etc.



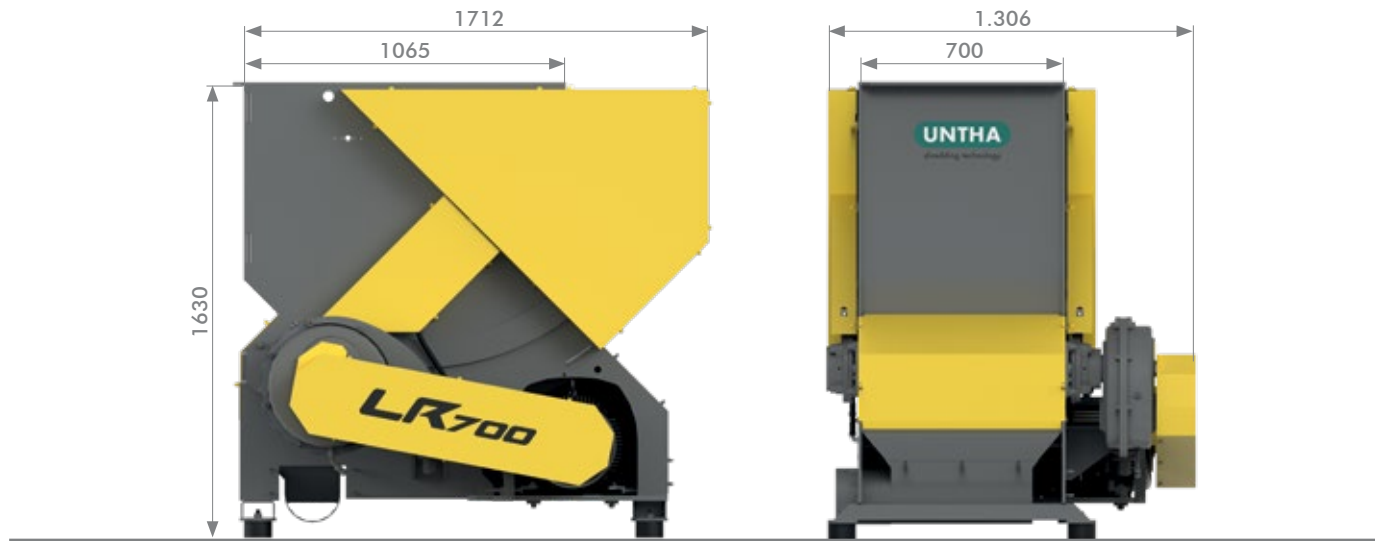

| TECHNICAL DATA | | LR700 |
|---|--------|---------------|
| Rated capacity | kW | 18.5/22 |
| Rated capacity of the hydraulic system | kW | 1.1 |
| Ø Rotor | mm | 300 |
| Rotor speed | rpm | 98 |
| Number of indexable inserts | pcs. | 19 |
| Feed opening | mm | 700 x 1,065 |
| Ø Suction nozzles | mm | 200 |
| Required suction speed | m/s | 28 |
| Recommended pipe cross section | mm | 200 |
| Weight | kg | approx. 1,800 |
| Workspace-specific sound pressure level LPA 1 m | dB (A) | 82 |
| Ø perforated screen | mm | 15 - 40 |
| Throughput rates* | srm/h | Up to 6 |

*) Dependent on type of material and diameter of perforated screen
All dimensions in mm

Your benefits at a glance



Reliable, cost-effective cutting system

The large rotor diameter (300 mm) and screen surface and the use of a secondary cutting bar all ensure a high throughput.

The screw-in, exchangeable blade holders are easy and quick to replace in case of damage (for instance caused by solid metal parts). The precise cutting gap between the main/secondary cutting bar and the indexable inserts makes the shredding process particularly efficient. The main cutting bar is reversible and easy to exchange.

Unique geometry of the indexable inserts

The reusable indexable inserts have a long service life. Their unique cutting geometry ensures a “cut-as-you-pull” effect that makes for particularly effective shredding even of wet wood.

The positive connection between the indexable insert and the blade holders prevents the fastening bolt from becoming deformed. It is easy to loosen and remove even after many hours of operation.



Low-wear perforated screen

Depending on the requirements, a range of screens ensure the production of a pre-defined granulate. The shredded material is then removed via a suction mechanism or a screw conveyor.

The special design of the perforated screen provides a particularly homogeneous final product that is ideal for briquetting or use in a wood-chip heating system.

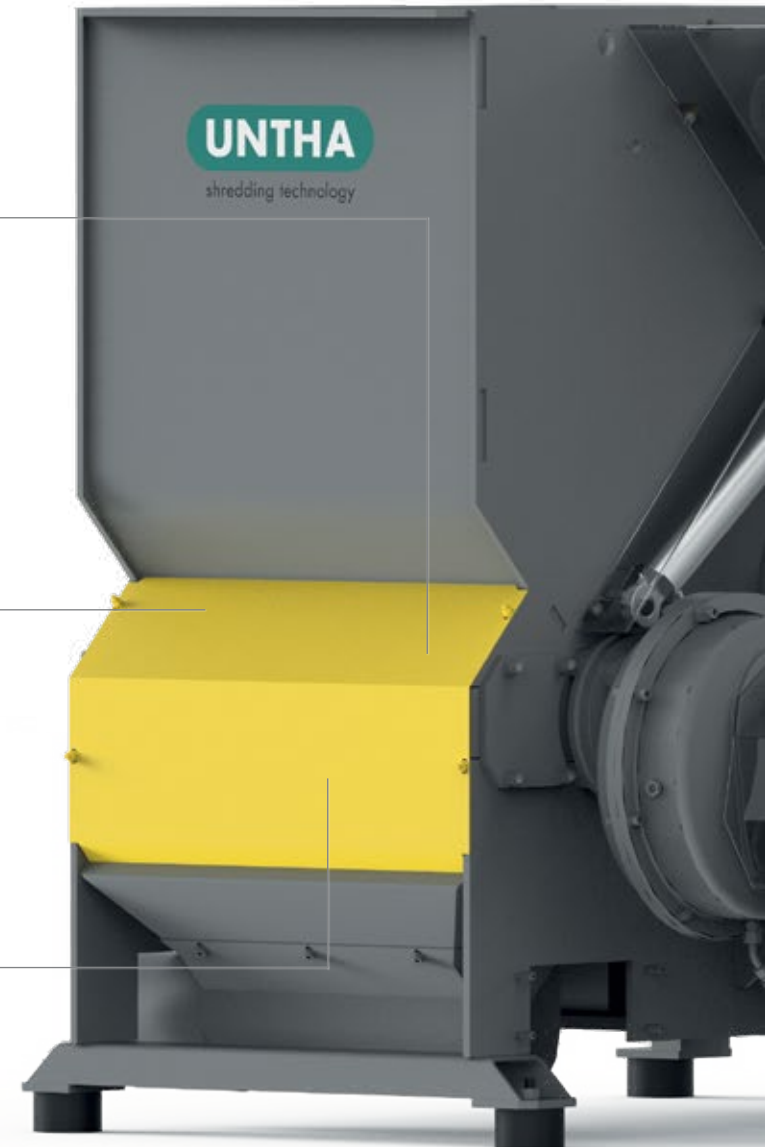



Powerful, low-wear swivelling pusher

The powerful, low-wear swivelling pusher pushes the residual wood against the rotor (load-dependent), ensuring a continuous material feed. Two pull-along hydraulic cylinders ensure a smooth and even feed-in for the swivelling pusher. The pusher guides are maintenance-free and not subject to any wear. The standard use of a fast hydraulic system results in a high throughput.

The hydraulic power unit is safely integrated in the machine frame/housing and yet easily accessible. Thanks to the compact design, the machine only has a small footprint.



Unique warranty

As a proof of our excellent product quality, we are happy to offer you a 3-year warranty*. Many renowned companies already put their trust in our quality standards.

*3 years or 2000 hours, depending on which value is reached first.



Energy-efficient, failure-free drive concept

The tried-and-tested belt drive and elastomer damper absorb shocks and vibrations and ensure the smooth running of the machine. The automatic reverse function, detection of non-shreddables and shut-off function protect the drive unit. The automatic shut-off function shuts down the machine when idling, further lowering energy costs.



Options

Mechanical extras

- » Second row of blade along the rotor for even higher throughputs
- » Profiled pusher floor for processing thin material
- » Material removal via screw conveyor

Electrical extras

- » Control system upgrade (light barrier, superordinate control system, BUS system, etc.)
- » Integration of peripheral devices into the control system
- » Suction mechanism activation
- » Automatic start

Accessories

- » Customer-specific undercarriages
- » Range of discharge feed systems (conveyor belts, etc.)
- » Range of metal separation units

Service

- » UNTHA Carefree Packages (Basic, Standard, Professional): Ensure that machines are technically sound and ready for use at all times

LR1000/LR1400

Single-shaft shredding system

VERY POWERFUL, FOR HIGH THROUGHPUTS

The LR1000/LR1400 stand out for their high levels of reliability and performance. Probably the best-known representatives of the LR series, they are the first choice when it comes to demanding applications that require high throughputs.

Due to their high level of reliability, they are used by joiners, in sawmills and the timber-processing industry where large quantities of residual wood are produced. The homogeneous final product is extremely well suited for use in wood-chip heating systems or for manufacturing wood briquettes.

Areas of application

- » Hard and soft wood
- » OSB
- » Chipboard panels
- » MDF panels
- » Veneers
- » Cap pieces
- » Pallets
- » etc.



| MACHINE TYPE DIMENSIONS | LR1000 | LR1400 |
|-------------------------|-------------|-------------|
| B (mm) | 1,630/2,010 | 2,030/2,406 |
| B1 (mm) | 1,000 | 1,400 |
| H (mm) | 1,630 | 1,645 |
| T (mm) | 1,704 | 1,704 |
| T1 (mm) | 1,050 | 1,050 |



| TECHNICAL DATA | | LR1000 | LR1400 |
|--|--------|-----------------------------------|-----------------------------------|
| Rated capacity | kW | 22/30/2 x 18.5 | 30/2 x 22/2 x 30 |
| Rated capacity of the hydraulic system | kW | 1.1/1.1/1.5 | 1.5/1.5/1.5 |
| Rated capacity of the screw conveyor | kW | 0.55 | 0.55 |
| Ø Rotor | mm | 300 | 300 |
| Rotor speed | rpm | 98 | 98 |
| Number of indexable inserts | pcs | 27/54 | 38/76/114 |
| Feed opening | mm | 1,000 x 1,050/1,600 ¹⁾ | 1,400 x 1,050/1,600 ¹⁾ |
| Ø Screw conveyor | mm | 200 | 200 |
| Ø Suction nozzles | mm | 250 | 250 |
| Required suction speed | m/s | 28 | 28 |
| Recommended pipe cross section | mm | 250 | 250 |
| Weight | kg | 2,400 - 2,700 | 2,800 - 3,500 |
| Workspace-specific sound pressure level LPA 1m | dB (A) | approx. 82 | approx. 82 |
| Ø perforated screen | mm | 15 - 40 | 15 - 40 |
| Throughput rates* | srm/h | Up to 8 | Up to 10 |

*) Dependent on type of material and diameter of perforated screen
¹⁾ With 45° machine frame

All dimensions in mm

Your benefits at a glance

Robust and compact design

The robust machine frame and high-grade components have a particular long service life. Thanks to the compact design, the machine only has a small footprint.



Reliable, cost-effective cutting system

The large rotor diameter (300 mm) and screen surface and the use of a secondary cutting bar all ensure a high throughput.

The screw-in, exchangeable blade holders are easy and quick to replace in case of damage (for instance caused by solid metal parts). The precise cutting gap between the main/secondary cutting bar and the indexable inserts makes the shredding process particularly efficient. The main cutting bar is reversible and easy to exchange.

Unique geometry of the indexable inserts

The reusable indexable inserts have a long service life. Their unique cutting geometry ensures a "cut-as-you-pull" effect that makes for particularly effective shredding even of wet wood.

The positive connection between the indexable insert and the blade holders prevents the fastening bolt from becoming deformed. It is easy to loosen and remove even after many hours of operation.



Low-wear perforated screen

Depending on the requirements, a range of screens ensure the production of a defined granulate. The shredded material is then removed via a suction mechanism or a screw conveyor.

The special design of the perforated screen provides a particularly homogeneous final product that is ideal for briquetting or use in a wood-chip heating system.

Powerful material discharge system

The screw conveyor is integrated as standard and removes material reliably and speedily.





Powerful, low-wear swivelling pusher

The powerful, low-wear swivelling pusher pushes the residual wood against the rotor (load-dependent), ensuring a continuous material feed. Two pull-along hydraulic cylinders ensure a smooth and even feed-in for the swivelling pusher. The pusher guides are maintenance-free and not subject to any wear. The standard use of a fast hydraulic system results in a high throughput.

The hydraulic power unit is safely integrated in the machine frame/housing and yet easily accessible. Thanks to the compact design, the machine only has a small footprint.



Unique warranty

To reflect our confidence in this product, we are able to offer an extended warranty of up to 3 years or 2000 hours, subject to material type. T&Cs apply.



Energy-efficient, failure-free drive concept

The tried-and-tested belt drive and elastomer damper absorb shocks and vibrations and ensure the smooth running of the machine. The automatic reverse function, detection of non-shreddables and shut-off function protect the drive unit. The automatic shut-off function shuts down the machine when idling, further lowering energy costs.

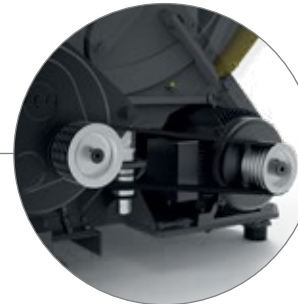

Options

Mechanical extras

- » 45° machine housing for a higher filling volume
- » Second row of blades along the rotor for even higher throughputs
- » Profiled pusher floor for processing thin material
- » Pallet swivelling pusher

Electrical extras

- » Control system upgrade (light barrier, superordinate control system, BUS system, etc.)
- » Integration of peripheral devices into the control system
- » Suction mechanism activation
- » Automatic start

Accessories

- » Customer-specific undercarriages
- » Range of discharge feed systems (conveyor belts, etc.)
- » Range of metal separation units

Service

- » UNTHA Carefree Packages (Basic, Standard, Professional): Ensure that machines are technically sound and ready for use at all times

RS30/40

4-shaft shredding system

DURABLE SOLID WOOD SHREDDERS FOR INTENSIVE CONTINUOUS OPERATION

The highly reliable RS30 and RS40 shredders are used in the woodworking and timber-processing industry. They stand out for their high availability and productivity.

The 4-shaft cutting system may be adapted to the input material and is particularly well suited for processing bark, solid wood and residual wood with metal inclusions.

Thanks to their compact design, the 4-shaft shredders are suitable for the decentralised recycling of wood pieces directly next to the production machines. The RS units have a particularly sturdy design that is meant for permanent operation. The low maintenance requirements and high operational performance result in particularly low operating costs.

Areas of application

- » Solid wood (long parts, splinters)
- » Bark
- » etc.



| MACHINE TYPE DIMENSIONS | L | H | H1 | W | D | D2 |
|------------------------------|-------|-------|-----|-------|-------|-------|
| RS30/2 x 5,5 kW | 1,410 | 1,900 | 860 | 1,000 | 1,300 | 1,090 |
| RS30/2 x 7,5 kW | 1,450 | 1,900 | 860 | 1,000 | 1,300 | 1,090 |
| RS30/2 x 11 kW | 1,500 | 1,900 | 860 | 1,000 | 1,300 | 1,090 |
| RS40/2 x 15 kW | 1,620 | 1,990 | 880 | 1,020 | 1,410 | 1,190 |
| RS40/2 x 15 kW 2 x 18,5 kW | 1,930 | 1,990 | 880 | 1,290 | 1,410 | 1,190 |
| RS40/2 x 18,5 kW | 2,160 | 1,990 | 880 | 1,520 | 1,410 | 1,190 |

All dimensions in mm CW - cutting unit width
 *Sample image (hopper and undercarriage are not included in the standard scope of delivery)

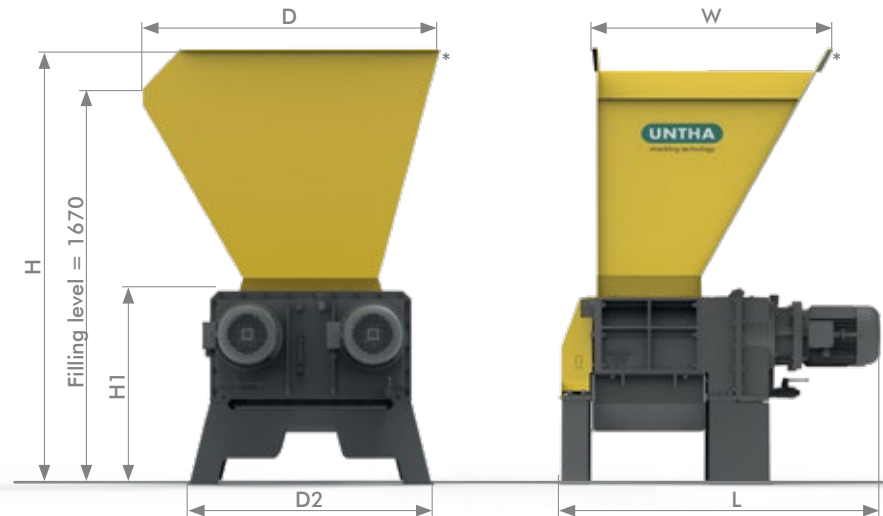

| TECHNICAL DATA | | RS30 | RS40 |
|--|--------|------------------------|---------------------------|
| Rated capacity | kW | 2 x 5.5/2 x 7.5/2 x 11 | 2 x 15/2 x 18,5 |
| Cutter clearance | mm | 450 x 560 | 480/750/960 x 700 |
| Number of shafts | pcs. | 4 | 4 |
| Speed of the main shaft | rpm | approx. 23 | approx. 24 |
| Speed of the secondary shaft | rpm | approx. 34 | approx. 32 |
| Ø perforated screen | mm | 15 - 40 | 15 - 40 |
| Weight | kg | approx. 1,100 | approx. 1,700/2,100/2,400 |
| sound pressure level LPA 1m | dB (A) | approx. 80 | approx. 80 |
| Throughput* Perforated screen Ø 15 - 25 mm | srn/h | Up to 3 | Up to 7 |

*) Dependent on type of material and diameter of perforated screen

Your benefits at a glance



Economical cutting system

The material is pulled in by the cutting system, eliminating the need for a pusher. The slow-running cutting system keeps noise and dust levels low. The 4-shaft cutting system has a service life of several thousand hours and is highly resilient towards non-shreddables.

Robust and compact design

High-grade components and a unique cast iron frame ensure a long service life and make this shredder one of the most robust models in its class. Thanks to its compact design, the unit requires little space and is easy to integrate into existing plants.



Defined fraction size

Depending on the requirements, a range of screens ensure the production of pre-defined wood chips. Thanks to chip breakers, the wood chips are particularly homogeneous and precisely adapted to the downstream processing step (briquetting, wood-chip heating system). The large screen area achieves high throughput rates.



Unique warranty

As a proof of our excellent product quality, we are happy to offer you a 3-year warranty*. Many renowned companies already put their trust in our quality standards.

*3 years or 2000 hours, depending on which value is reached first.



Electronic protection systems

The automatic detection of non-shreddables with shut-off function and the automatic reverse function in case of motor overload protect the drive unit against damage. The automatic shut-off function shuts down the machine when idling, further lowering energy costs.

Reliable drive system

Reduced start-up current and power peaks thanks to staggered start-up of the two motors and low-maintenance, resilient gears that run in an oil bath ensure a high torque for the chopping discs.

The straightforward design makes this unit highly fault-resistant and keeps maintenance levels to a minimum.



Options

Mechanical extras

- » Customer-specific chopping discs available upon request
- » Automatic central lubrication
- » Reinforced perforated screen

Electrical extras

- » Control system upgrade (light barrier, superordinate control system, BUS system, etc.)
- » Integration of peripheral devices into the control system
- » Suction mechanism activation
- » Automatic start

Accessories

- » Suction hoods (suction is possible on four sides)
- » Customer-specific feed hoppers and undercarriages
- » Range of discharge feed systems (conveyor belts, screw conveyors , etc.)
- » Range of metal separation units

Services

- » UNTHA Carefree Packages (Basic, Standard, Professional): Ensure that machines are technically sound and ready for use at all times

The best testimonials **worldwide**

Numerous satisfied customers from the woodworking and timber-processing industry already place their trust in our competent solutions.





Reliability throughout the lifetime of your unit

UNTHA Service Competence Center

UNTHA shredders are in operation all over the world and appreciated for their longevity and reliability. And if there is an unplanned machine shutdown or unexpected challenges occur, our service experts are quick to help.

With the UNTHA Service Competence Center, we assist you throughout the entire product lifecycle and offer you comprehensive service products to maximise the availability of your machine. From regular maintenance and the provision of replacement and wear parts to our individual Carefree Packages, we ensure that UNTHA machines are ready for use at all times and do what they were built for: the reliable shredding of material.

To ensure that your inquiry is dealt with swiftly, please have the following information ready:

- » Manufacturing number
- » Machine type
- » Operating hours
- » Serial number of components and parts (where applicable)
- » Year of manufacture





UNTHA

shredding technology

SERVICE

www.untha.com

UNTHA shredding technology GmbH

Kellau 141
5431 Kuchl | Österreich
Tel.: +43 6244 7016 0
Fax: +43 6244 7016 1
info@untha.com
www.untha.com

UNTHA UK Ltd.

Excel House, Becklands Close
Boroughbridge
YO51 9NR | United Kingdom
Tel.: +44 330 056 4455
sales@untha.co.uk
www.untha.co.uk

5 reasons to choose UNTHA



Customised, long-lasting shredding solutions



Premium products developed and manufactured in Austria



All-encompassing expertise, from development to production, under one roof



Reliable customer service with the best technical know-how



More than 10,000 satisfied reference customers worldwide

We deliver what we promise

Since our founding in 1970, we've followed our promise of being "the reliable brand", which applies to every product and service that UNTHA delivers.

We work hard to consistently outperform our competitors, and provide customers with the confidence that – in choosing UNTHA – they have made the best decision for their business.

All revisions reserved. Subject to setting and printing errors.
All illustrations are representative and may deviate from the actual product.
© 11/22 UNTHA shredding technology