

# TraceNet™ ECM Series Control System

---

## ECM Operating Guide



---

## ECM Operating Guide

©2014, 2015 Thermon, Inc. All Rights Reserved.

This guide, as well as the firmware described in it, is furnished under license and may only be used or copied in accordance with the terms of such license. The information in this guide is furnished for informational use only, is subject to change without notice, and should not be construed as a commitment by Thermon, Inc. Thermon assumes no responsibility or liability for any errors or inaccuracies that may appear in this guide.

This document may not, in whole or in part, be copied, photocopied, reproduced, translated, or reduced to any electronic medium or machine-readable form without prior consent in writing from Thermon Manufacturing Company. This document is subject to change without notice.

Written and designed at Thermon, Inc.  
100 Thermon Drive, San Marcos, TX 78667-0609, USA

This operating guide is designed solely for use by owners of TraceNet™ ECM Series heat tracing control systems. The firmware and operating guide are considered proprietary and are protected by copyright. Use by others without expressed written consent of Thermon is strictly prohibited.

# Contents

<b>Part 1: Introduction</b>	4
<b>Part 2: ECM Specifications</b>	6
<b>Part 3: Terminology</b>	8
<b>Part 4: ECM User Interface</b>	9
<b>Part 5: Types of ECM Modules</b>	13
<b>Part 6: The ECM-C and ECM-CH Control Module in Operation</b>	16
<b>Part 7: The ECM-CL Control and Limiter Module in Operation</b>	22
<b>Part 8: The ECM RS485 Communications</b>	31
<b>Part 9: Installation Requirements</b>	32
<b>Part 10: Interpreting the Flash Sequence of the Alarm LED</b>	33
<b>Part 11: Further Information</b>	35
<b>Appendix A: ECM Factory Default Settings and Ranges</b>	36

# 1 Introduction

The Trace Net ECM (Electronic Control Module) is an electronic temperature control and monitoring module specifically designed for controlling electric heat tracing circuits used in freeze protection and temperature maintenance applications. The Terminator ECM serves as the temperature control, data transmitter, and the sensor and power connection for a heat trace circuit.



**Figure 1: ECM Control Module in Terminator or Stainless Enclosure**

The ECM is housed in either a glass reinforced nonmetallic enclosure (Terminator series) with an environmental rating of NEMA 4X/IP66 or a stainless enclosure (OS series) with an environmental rating of IP66/67. Depending on options selected, the ECM may be used as a combination temperature control and limiter, a temperature controller with either a low temperature or a high temperature alarm function, or a temperature limiter only. Rotary switches are provided within the enclosure for adjusting the temperature control and/or limiter set points. The standard version of the ECM communicates on a physical network of RS485 by using a Modbus RTU communication protocol. Alternately, a CAN communication option is also available.

The TraceNet ECM Series of heat tracing control and monitoring modules have been approved/certified for installation and operation in Ordinary and Class 1 Division 2 Groups A, B, C, and D, and Zone 1 and 2 hazardous (classified) locations in potentially explosive atmospheres.

**TraceNet ECM™**

CE 1725  II 2 (2) GD Ex eb mb [ib] IIC T4, Ex tb IIIC T135°C SIRA 12ATEX5239X

 SIR 12.0103X Ex eb mb [ib] IIC T4, Ex tb IIIC T135°C

 14.2709489X Ex eb mb [ib] IIC T4, Ex tb IIIC T135°C  
Class I Division 2, Groups A, B, C, D; Class II Division 2 Groups F, G; Class III; T4  
Class I Zone 1, AEx eb mb [ib] IIC T4; Zone 21 AEx tb IIIC T135°C

 OCP 0034 NCC 15.0035X Ex eb mb [ib] IIC T4, Ex tb IIIC T135°C

DNV (ECM-OS only) E-14179, DNV's Rules for Classification of Ships, High Speed & Light Craft and DNV's Offshore Standards

# 2 ECM Specifications

The ECM has the following operating specifications:

Nominal Operating/Control Voltage	120/208/240 Vac <sub>1</sub> (50/60 Hz)
Operating Ambient Range	-76 to 13°F (-60 to 55°C)
Minimum Ambient Storage Range	-100°F (-74°C)
Control Switch Options	SPST/DPST
Control Capacity	One heat tracing circuit
Temperature Inputs	One or two 3 wire 100 Ohm @ 32°F (0°C) platinum RTD's per heat trace circuit, intrinsically safe input circuitry
Temperature Units	°F/°C
Temperature Control Range	32°F to 932°F (0°C to 500°C)
Temperature Measurement Range	-76°F to 932°F (-60°C to 500°C)
Communication Options	RS485 / CAN
RS485 Communication Protocol	ModBus RTU

Communication Rate 9600 Baud  
 High Temperature Alarm/Trip Selectable (manual or automatic reset)  
 Alarm Relay Current Ratings 2 Amps  
 Alarm Relay Contact Voltage Rating 120/208/230/240 Vac<sup>1</sup>  
 Control Method On/Off

1 - Applied nominal voltage is dependent on model number

Installation Category II

Pollution Category 2

Control Relay Switch Rating See Table

Heater Load AC Current Switching Rating		
Tamb. °F (°C)	Double pole (DP) Type A Current Rating (Amps)	Single pole (SP) Type B Current Rating (Amps)
59 (15)	30	30
68 (20)	29	30
77 (25)	28	30
86 (30)	26.4	30
95 (35)	24.8	30
104 (40)	23	30
113 (45)	21	30
122 (50)	19	25.8
131 (55)	17	20

# 3 Terminology

The following terminology will be assumed in this operating guide.

<b>Maintain Temperatures</b> (Controller Set Temperature)	The temperatures at which the heater load relay will switch
<b>Temperature Control Band</b> (Temperature Differential Value)	The value between the maintain temperature and switch-off temperature.
<b>Alarm Control Band</b> (Low Alarm Controller or Alarm Differential Value)	The Temperature Difference value below the Maintain Temperature or above the Maintain Temperature that the ECM will generate a temperature alarm.
<b>Low Temperature Alarm</b>	Maintain Temperature minus Alarm Control Band
<b>High Temperature Alarm</b>	Maintain Temperature plus Alarm Control Band



# 4 ECM User Interface

The ECM control module is as shown in Figure 2 below.

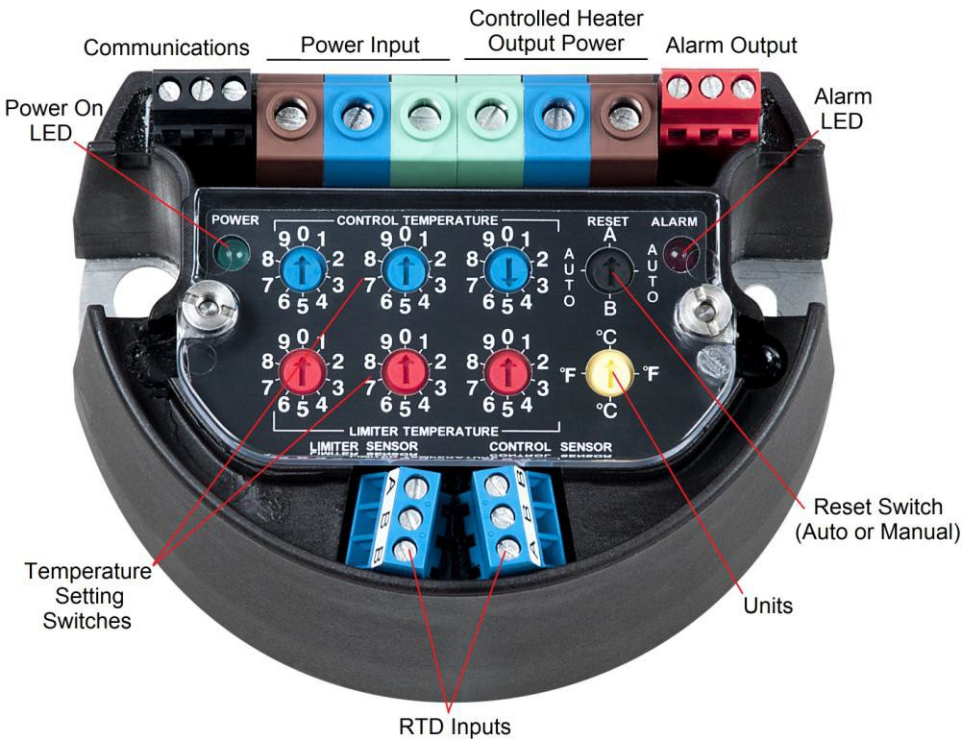

Figure 2: ECM-CL Control Module (shown)

Key interface features are as follows:

**Alarm LED:** Onboard, red Alarm LED is used to represent alarms in the system by using distinctive flashing sequences. This allows users with hot work permits to make an initial assessment of the alarms.

**Power LED:** A green power LED is used to indicate that the ECM module is powered within the operating voltage range. The Power LED will not illuminate if the voltage drops below 102 Vac for the 120 Vac nominal voltage module, if the voltage drops below 188 Vac on the 208 Vac nominal voltage module or drops below 204 Vac on the 240 Vac nominal voltage module.

**Auto/Manual Reset:** The Auto/Manual Reset switch is used to reset the limiter if the temperature exceeds the High Temperature Trip Value. A switch is used to select the AUTO or MANUAL Reset modes. Another way of resetting the ECM is by removing the power to the unit (turning the circuit breaker “off” and then back “on”). When the user selects the Auto reset option, the limiter resets itself after the high temperature alarm is raised and once the temperature comes back within the safe control range.

Switch Position	Function Limiter
AUTO	= Automatic Reset
A	= Manual Reset
B	= Manual Reset

**NOTE:** In an ATEX hazardous location (potential explosive atmosphere present), a Manual Reset setting for the Limiter is mandatory.

**Heater Switching:** One mechanical relay (control or limiter) or two mechanical relays (combination control and limiter) is (are) provided within the ECM module. The brown, blue, and green terminals to the left are wired for incoming power. The green, blue, and brown terminals to the right are wired to the heat tracing load circuit.

**Alarm Relay:** An alarm relay with a single pole alarm contact rated for up to 2 Amps maximum current may be connected to external alarm devices (at the upper right red terminal blocks).

**Temperature Units:** The ECM module can be operated in either degrees Fahrenheit (°F) or degrees Celsius (°C). The user can select the desired temperature units by using the yellow temperature unit’s rotary switch.

**Wide Temperature Setting Range:** The user may adjust the Maintain Temperature (blue rotary switches) and High Temperature Trip Values (red rotary switches) for all the ECM module types in the range of 32°F to 932°F (0°C to 500°C). Even though the switches are labeled as set for the maximum value of 999, the ECM will still raise an alarm if outside of the temperature range value for the selected temperature units.

**Temperature Measurement Range:** Three-wire, platinum RTD temperature sensors are used to measure temperature in the range of -76°F to 932°F (-60°C to 500°C) and are connected into the bottom two sets of blue terminal blocks. The RTD temperature sensor is used with a compensation circuitry to yield accurate temperature readings by accounting for lead wire resistance. Input for the standard RTD elements is intrinsically safe.

**Temperature Measurement Accuracy:** The accuracy for the temperature measurements are in the following ambient temperature ranges:

- -76°F to 32°F (-60°C to 0°C)                      ±3.6°F (±2°C)
- 32°F to 131°F (0°C to 55°C)                      ±1.8°F (±1°C)

**Detection of Open/Short Circuit RTD Sensor:** The ECM is able to detect open/short circuit conditions of the RTD sensor and can raise an alarm to alert the user so that sensor can be serviced.

**Communication Physical Layers:** ECM modules can be provided with one of the three available communication connections:

- RS485 BUS
- CAN Bus

Wiring connections for the external communication capability is done at the black terminal blocks in the upper left corner of the module.

Details of the communication protocols, along with the packet structure (RS485 or CAN bus) may be found in the ECM DCS Guide (PN 50315\_0314).

Though not immediately recognizable in the user interface, the ECM has the following additional features.

**Independent Action:** The ECM Controller/Limiter has independent control and limiter functions as well as dual RTD inputs. It also requires a special tool to

change and alter settings and therefore meets the requirements as stated in IEC 60079-30 for use in Zone 1 applications (potentially explosive atmospheres).

**Under Voltage Protection:** Under voltage protection circuitry is built into the ECM modules to avoid chattering of control and limiter relays.

**Over-Temperature Protection:** Thermal fuses rated at 237°F (114°C) are used to protect the control circuitry in case the internal circuit temperature of the device rises unexpectedly. In addition to this, a Negative Temperature Coefficient (NTC) temperature sensor monitors the internal circuit temperature and de-energizes the controller and limiter relays with Auto Reset in case the internal circuit temperature exceeds 185°F (85°C). The ECM will resume temperature control once the internal circuit temperature cools to 176°F (80°C).

# 5 Types of ECM Modules

Three basic model types of the ECM are manufactured, as detailed below:

- **ECM-C:** Controller only, with low temperature Alarm contact capability. ECM-C controls the temperature to closely match the temperature set point (Maintain Temperature).
- **ECM-CH:** Controller only, with high temperature Alarm contact capability. ECM-CH controls the temperature to closely match the temperature set point (Maintain Temperature).
- **ECM-CL:** Controller and Limiter, with Alarm contact capability.

The standard version of the ECM communicates on a physical network of RS485 by using a ModBus RTU protocol. An optional version of the ECM is available for CAN communication output. To determine the ECM options provided, refer to either of the following two model code descriptions, either with a Terminator or with a wall-mount enclosure.

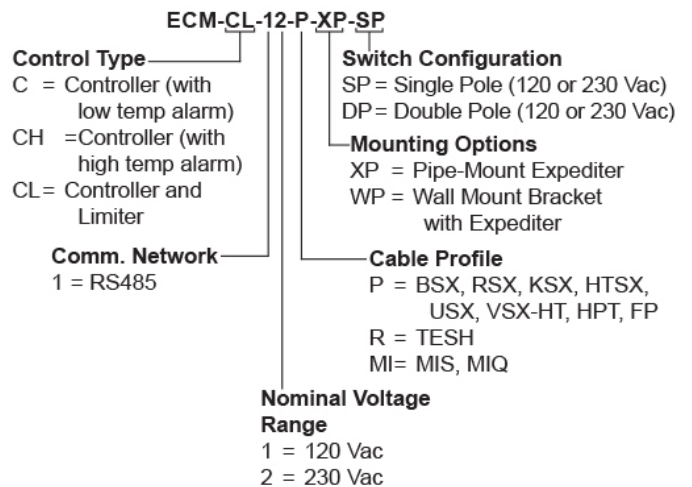
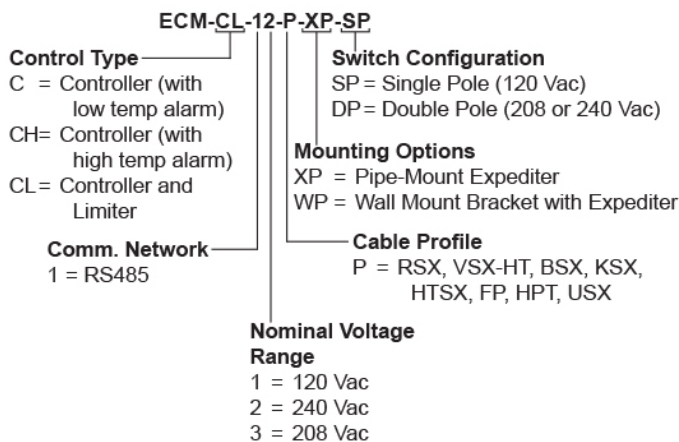

The TraceNet ECM is typically designed to be mounted on the heated pipe or surface with a Terminator, or wall-mounted with an enclosure as shown in Figure 3.

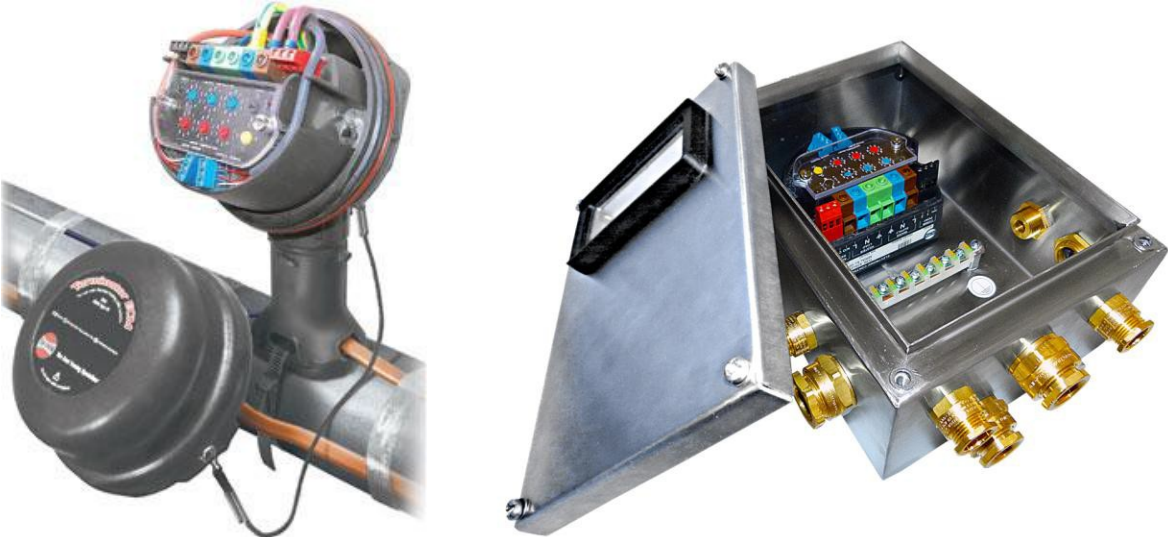

**Figure 3:** ECM Control and Monitoring Module Mount Options

When installed, the TraceNet ECM module's nominal outer dimensions are as shown in Figure 4.

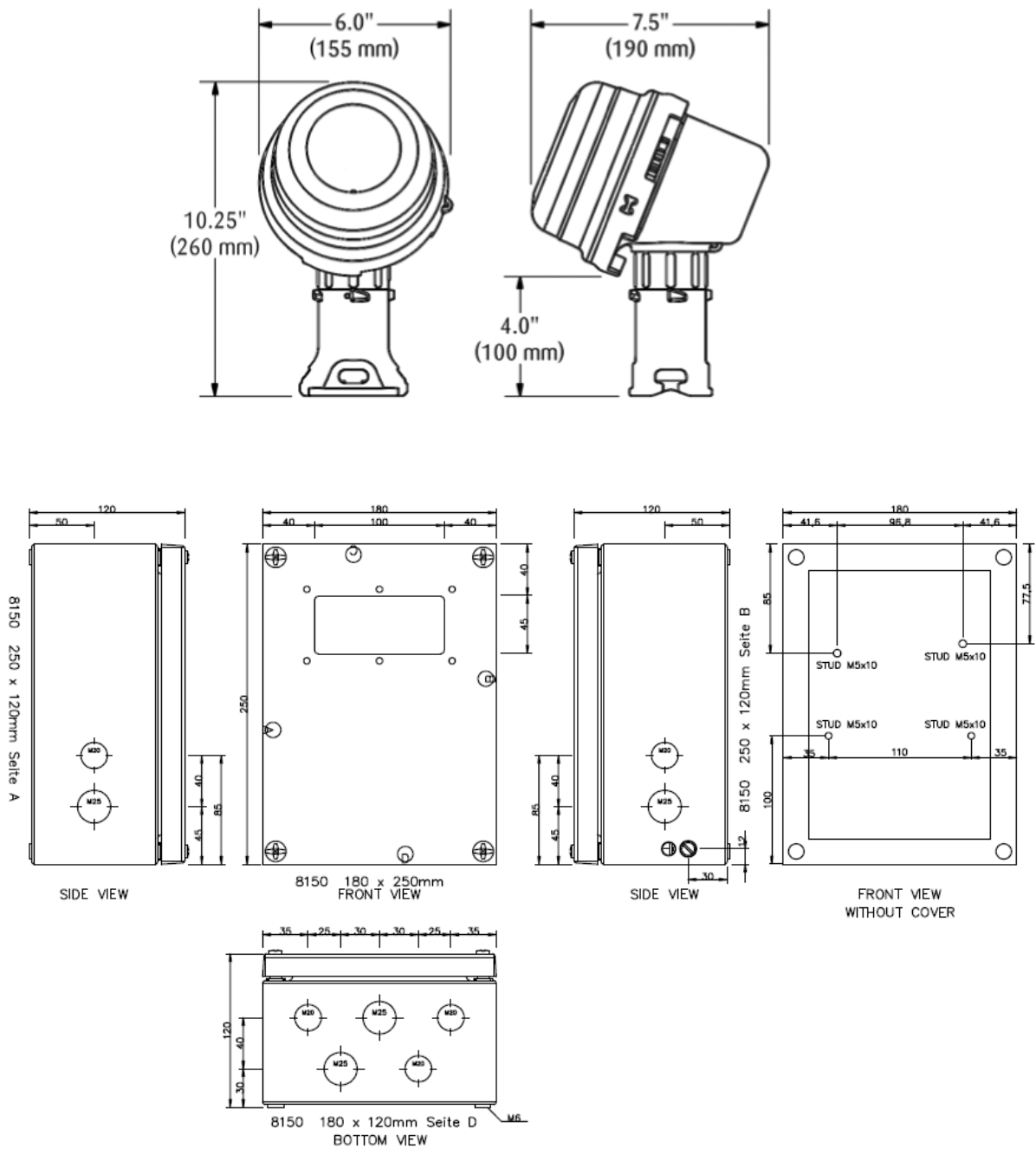

**Figure 4: TraceNet ECM Dimensions**

# 6 The ECM-C and ECM-CH Control Module in Operation

The ECM-C and ECM-CH control and monitoring module is shown in Figure 5:

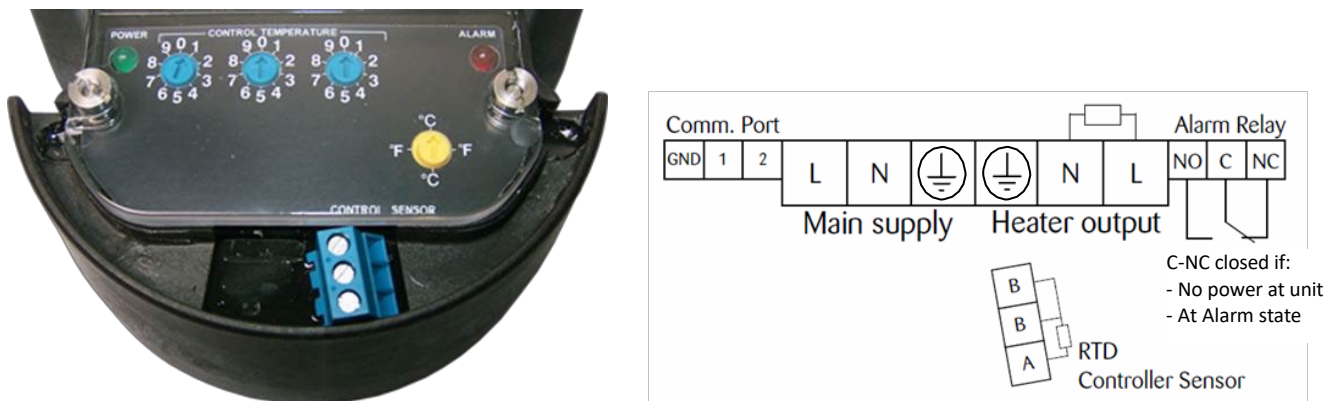

**Figure 5:** The TraceNet ECM-C/ECM-CH



The ECM-C and ECM-CH controls the heater load by simple on/off operation of the control relay to ensure that the temperature of the process is maintained within the required Maintain Temperature range.

If the temperature of the RTD control sensor is above the Maintain Temperature (adjusted using rotary switches) + Temperature Control Band, the Controller Relay will turn off and the power to the heater load will be disconnected. For the ECM-C, in case the temperature drops below the Maintain Temperature minus the (Low) Alarm Control Band (due to some other external factors), a Low Temperature Alarm will occur and the alarm relay will latch off. In this case, the Alarm LED will also flash to indicate that the controller sensor temperature has reached the Low Temperature Alarm Value. For the ECM-CH, in case the temperature goes above the Maintain Temperature plus the (High) Alarm Control Band (due to some other external factors), a High Temperature Alarm will occur and the alarm relay will latch off. In this case, the Alarm LED will also flash to indicate that the controller sensor temperature has reached the High Temperature Alarm Value.

When the RTD controller sensor reaches the Maintain Temperature again, the Alarm will turn off. At this point, the alarm contact will be energized and the Alarm LED will stop flashing.

In order to power the heater load again, the temperature of the RTD control sensor has to be less than or equal to the Maintain Temperature.

### Basic Settings:

- Select the appropriate Temperature Units by adjusting the yellow rotary switch.
- Select the desired Set Point Temperature in the range of 32°F to 932°F (0°C to 500°C) with the blue rotary switches.
- Note that the green Power LED indicates that the ECM is energized at the power terminals.

### Example Settings

Parameter	Selected Value	Parameter Type
Temperature Units	°C	User selectable
Maintain Temperature	100°C	User selectable
Temperature Control Type	On/Off	Factory settings
Temperature Control Band	3°C	Factory settings

Low Alarm Control Band	3°C	Factory settings†
High Alarm Control Band	10°C	Factory settings†

Parameter	Temperature
Control Relay Latch OFF Temperature	103°C
Temperature Value for raising Alarm (Low Temperature Alarm Threshold Value)	97°C
Temperature Value for raising Alarm (High Temperature Alarm Threshold Value)	103°C
Temperature Value for stopping Alarm	100°C
Control Relay Latch ON Temperature	100°C

**\* Temperature values at which control and alarm relays are latched**

On ECM-C/ECM-CH power up, if the temperature detected by the RTD Controller Sensor is equal to or below 216°F (102°C), ECM-C/ECM-CH will power the heater load. When the temperature of the RTD controller sensor is equal to or above 217°F (103°C) (Maintain Temperature + Temperature Control Band), the controller relay will be latched off after a specified delay (5 seconds) in order to turn off the heater. The delay used to turn a relay on or off is set by the factory.

Once the temperature of the RTD Controller Sensor cools down to 212°F (100°C), the ECM-C/ECM-CH will power the heater load again.

For the ECM-C, if (due to some external factor) the RTD sensor temperature drops below 207°F (97°C) (Maintain Temperature minus Alarm Control Band), the Alarm Relay will latch off to raise a low temperature alarm. At the same time, the Alarm LED will flash to indicate the type of alarm event. For the ECM-CH, if (due to some external factor) the RTD sensor temperature goes above 217°F (103°C) (Maintain Temperature plus Alarm Control Band), the Alarm Relay will latch off to raise a high temperature alarm. At the same time, the Alarm LED will flash to indicate the type of alarm event.

†Alarm control band may be factory set at a lower or higher value if specified in the order. The alarm control band may also be field-adjusted through the use of TVNE data highway communication software if the ECM contains the RS485 communication option.

## ECM-C and ECM-CH Alarms

The red Alarm LED indicates existing alarms detected by the ECM-C/ECM-CH module and annunciates them by using different delays and flash sequences. A list of alarms and flash sequences for ECM-C/ECM-CH is given in the table included at the end of this section.

Alarms are also logged in the ECM-C/ECM-CH microprocessor’s memory along with the time at which the event was detected. When the ECM does not contain any alarm conditions, it will send “0x00” as the alarm status code when requested to do so via the serial data communication output.

A list of alarms and their flash sequence is given in the following table.

### ECM-C/ECM-CH Alarm Table

	System Alarm, Software	RTD Controller Alarm	Invalid Maintain Temperature Min
Alarm Condition	Software failure established in the microprocessor	Controller RTD Open/Short <sub>1</sub>	Controller Maintain Temperature Value < Min Maintain Temperature value in °F/°C or Controller Maintain Temperature Value > Max Maintain Temperature value in °F/°C
Action	De-Energize Control Relay and Raise Alarm	De-Energize Control Relay and Raise Alarm	De-Energize Control Relay and Raise Alarm
Control Relay	De-Energized	De-Energized	De-Energized
Alarm Relay	De-Energized	De-Energized	De-Energized

<b>Alarm Code</b>	0x11	0x21	0x41
<b>Alarm LED</b> (Flash, Delay(s))	(1, one)	(2, one)	(4, one)
<b>Self Resettable Function &amp; Condition</b>	Yes (if microprocessor resets) OR (Alarm cleared using the serial communication)	Yes (Sensor Repaired)	Yes (Correct Maintain Temperature value)
	<b>Invalid Maintain Temperature Max</b>	<b>Low Temperature Alarm</b>	<b>High Temperature Alarm</b>
<b>Alarm Condition</b>	Controller Maintain Temperature Value > Max Maintain Temperature value in °F / °C	Controller Sensor Temperature < (Controller Maintain Temperature Value - Low Temperature Alarm offset value)	Controller Sensor Temperature > (Controller Maintain Temperature Value + Temperature Control Band Value + High Temperature Alarm offset value)
<b>Action</b>	De-Energize Control Relay and Raise Alarm	Raise Alarm (Control Relay already De-Energized)	Raise Alarm (Control Relay already De-Energized)
<b>Control Relay</b>	De-Energized	Already De-Energized	Already De-Energized
<b>Alarm Relay</b>	De-Energized	De-Energized	De-Energized
<b>Alarm Code</b>	0x42	0x72	0x72
<b>Alarm LED</b> (Flash, Delay(s))	(4, two)	(7, two)	(7, two)
<b>Self Resettable Function &amp; Condition</b>	Yes (Correct Maintain Temperature value)	Yes (Sensor Temperature in differential range)	Yes (Sensor Temperature in differential range)

	High Temperature Trip Internal	Low Voltage Trip	Hardware Shutdown
<b>Alarm Condition</b>	Internal NTC Temperature $\geq$ Max Internal Circuit Temperature Threshold value	Mains Supply < 204 Vac / 188 Vac / 102 Vac <sup>2</sup>	Internal Circuit Temperature $\geq$ 212°F / 100°C
<b>Action</b>	De-Energize Control and Alarm Relays	ECM turned off and Alarm Raised	ECM will shut down and may be damaged permanently, Alarm Raised (fail safe)
<b>Control Relay</b>	De-Energized	De-Energized	De-Energized
<b>Alarm Relay</b>	De-Energized	De- Energized	De-Energized
<b>Alarm Code</b>	0x81	0x92	-----
<b>Alarm LED</b> (Flash, Delay(s))	(8, one)	-----	-----
<b>Self Resettable Function &amp; Condition</b>	Yes (Safe internal circuit temperature)	Yes (Mains Supply = 204 Vac / 188 Vac / 102 Vac)	No

<sup>1</sup> Occasionally open circuit and short circuit conditions of the RTD can be mixed.

<sup>2</sup> The alarm code will be logged in the microprocessor memory once the module powers up again. This alarm code indicates that the ECM has gone through a power cycle.

# 7 The ECM-CL Control and Limiter Module

The ECM-CL control and limiter monitoring module is shown in Figure 7 below.

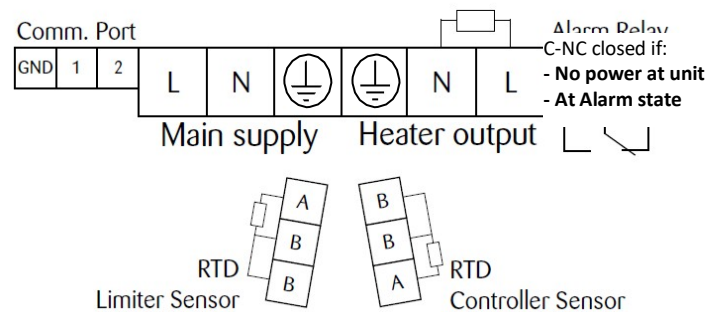

Figure 7: ECM Control and Limiter

The ECM Controller/Limiter controls the heater load by simple on/off operation of both Controller and Limiter Relays. In this module, two relays are used to ensure that the temperature of process is maintained within the safe operating range.

## The ECM-CL in Operation

In the ECM-CL, two microprocessors are used for dual redundancy. The two microprocessors are linked by internal serial communication to constantly monitor the health of each other. This ensures that if one microcontroller fails, the other microprocessor can alert the control room by raising the System Alarm. This adds an additional security feature to the ECM-CL module which is ideal in safety critical applications.

In this guide, operation of the microprocessors is categorized as Controller for the Controller Relay, and Limiter for Limiter Relay, as symbolized by the name of the product ECM-CL.

The Controller seeks to maintain the process temperature within the safe temperature range by switching the control relay on or off. The Limiter acts as a watchdog by controlling the Limiter Relay so that the load heater can be turned off when the temperature has exceeded the maximum High Temperature Trip value of the limiter. In ECM-CL, the High Temperature Trip value of the limiter should be adjusted higher than the Controller Set Temperature in order to ensure that the Limiter can restrict temperature rise by de-energizing the Limiter Relay.

The ECM-CL controls the heater load by simple on/off operation of the control relay to ensure that the temperature of the process is maintained within the required Maintain Temperature range.

If the temperature of the RTD control sensor is above the Maintain Temperature (adjusted using rotary switches) + Temperature Control Band, the Controller Relay will turn off and power to the heater load will be disconnected. In case the temperature drops below the Maintain Temperature minus the (Low) Alarm Control Band (due to some other external factors), a Low Temperature Alarm will occur and the alarm relay will latch off. In this case, the Alarm LED will also flash to indicate that the controller sensor temperature has reached the Low Temperature Alarm Value.

When the RTD controller sensor reaches the Maintain Temperature again, the Alarm will turn off. At this point, the alarm contact will be energized and the Alarm LED will stop flashing.

In order to power the heater load again, the temperature of the RTD control sensor has to be less than or equal to the Maintain Temperature.

**Auto/Manual Reset:** Control of the Limiter Relay is based on latching off control with Auto or Manual Reset (setting through the black rotary switch). This switch has 4 settings: two positions for Automatic (Auto) Reset and two for Manual (A, B) Reset.

When the temperature of the RTD Limiter Sensor exceeds the High Temperature Trip value (adjusted using the red rotary switches) and the position of the Reset Switch was selected to be A, or B (Manual Reset), the Limiter Relay will latch off and power to the heater will be disconnected. At the same time an alarm will be raised to indicate that the RTD Limiter Sensor temperature has exceeded the temperature

limit set by the user. In this case, the Alarm LED will also flash to indicate that the Limiter Sensor Temperature is at a critical value. In order to remove the High Temperature Trip Alarm after the temperature has returned to the safe range, the Manual Reset or Auto Reset must be again selected using the Reset Switch. Limiter reset can also be accomplished by power cycling the ECM (turning the breaker “off” and then back “on”) without changing the Reset Switch.

When the temperature of the RTD Limiter Sensor exceeds the High Temperature Trip value (adjusted using red rotary switches) and the position of the Reset Switch is in AUTO, the Limiter Relay will latch off and power to the heater will be disconnected. At the same time an alarm will be raised to indicate that the RTD Limiter Sensor temperature has exceeded the temperature limit set by the user. In this case, the Alarm LED will also flash to indicate that the Limiter Sensor Temperature is at a critical value. The High Temperature Trip Alarm will be removed and the heater load will be powered again once the temperature of the RTD Limiter Sensor is less than or equal to the High Temperature Trip value minus the Negative Limiter Control Band value. At this point the Alarm has been removed and the Alarm LED will stop flashing.

## **Basic Settings**

- Select the appropriate Temperature Units by adjusting the yellow rotary switch.
- Select the desired Control Relay Set Point Temperature in the range of 32°F to 932°F (0°C to 500°C) with the blue rotary switches.
- Select the desired Limiter Relay Set Point Temperature in the range of 32°F to 932°F (0°C to 500°C) with the red rotary switches.
- Note that the green Power LED indicates that the ECM is energized from the power terminals.



## Typical Example Settings

Parameter	Selected Value	Parameter Type
Temperature Units	°C	User selectable
Maintain Temperature	100°C	User selectable
Temperature Control Type	Offset	Factory settings
Temperature Control Band	3°C	Factory settings
High Temperature Trip value	200°C	User selectable
Reset Type	Auto	User selectable
Alarm Control Band Type	Offset	Factory settings
Alarm Control Band Value	10°C	Factory settings

**\* Assuming no alarms detected by the Controller microprocessor and Alarm Relay latched ON**

Parameter	Temperature
Control Relay Latch OFF Temperature	103°C
Control Relay Latch ON Temperature	100°C
Limiter Relay Latch OFF Temperature	200°C
Temperature Value for raising Alarm (Alarm Threshold Value)	200°C
Temperature Value for stopping Alarm	190°C
Limiter Relay Latch ON Temperature	190°C

**\* Temperature values at which control and alarm relays are latched**

On ECM-CL power up, if the temperature detected by the RTD Controller Sensor is equal to or below 102°C, ECM-CL will power the heater load. When the temperature of the RTD controller sensor is equal to or above 103°C (Maintain Temperature + Temperature Control Band), the controller relay will be latched off after a specified delay (5 seconds) in order to turn off the heater. The delay used to turn a relay on or off is set by the factory.

Once the temperature of the RTD controller sensor cools down to 100°C, the ECM-CL will power the heater load again.

Upon power-up, the ECM-CL will also sense the temperature using the RTD Limiter Sensor. If that temperature is below 392°F (200°C), the ECM-CL Limiter Relay will remain closed. When the temperature of the RTD Limiter Sensor is equal to or above 392°F (200°C) (High Temperature Trip value), the Limiter and Alarm Relays will be latched off to raise an alarm after a specified delay (5 seconds). At the same time the Alarm LED will also flash to indicate the type of alarm.

When the temperature of the RTD Limiter sensor approaches 374°F (190°C), the High Temperature Trip Alarm will be removed and the Limiter Relay will again close. At the same time the Alarm LED will stop flashing.

The delay used to turn a relay on or off is set by the factory. A list of user-customized parameters and their ranges are given in the Appendix A.

## ECM-CL Alarms

The red Alarm LED indicates any alarms detected by the ECM-CL module and annunciates them with different delays and flash sequences. A list of alarms and flash sequences for ECM-CL is given in the table included at the end of this section.

Alarms are also logged in the ECM-CL microprocessor’s memory along with the operational time at which the event was detected. When the ECM does not contain any alarm conditions, it will send “0x00” as the alarm status code when requested to do so via the serial data communication output.

A list of alarms and their flash sequence is given in the following table.

### ECM-CL Alarms Table

	System Alarm, Software	System Alarm, Communication	RTD Controller Alarm
<b>Alarm Condition</b>	(Software failure established in the microprocessor)	(Communication failure established between the microprocessors)	(Controller RTD Open/Short <sup>1</sup> )
<b>Action</b>	De-Energize Limiter/Control Relay and Raise Alarm*	De-Energize Limiter/Control Relay and Raise Alarm*	De-Energize/Energize Control Relay and Raise Alarm
<b>Control Relay</b>	*De-Energized	*De-Energized	De-Energized / Energized
<b>Limiter Relay</b>	*De-Energized	*De-Energized	No Action
<b>Alarm Relay</b>	De- Energized	De-Energized	De-Energized

<b>Alarm Code</b>	0x11	0x12	0x21
<b>Alarm LED (Flash, Delay(s,))</b>	(1, one)	(1, two)	(2, one)
<b>Self-Resettable Function &amp; Condition</b>	Yes (if microprocessor resets) OR (Alarm cleared using the serial comms)	Yes (if microprocessor resets) OR (Alarm cleared using serial comms)	Yes (Sensor Repaired)
	<b>RTD Limiter Alarm</b>	<b>Invalid Maintain Temperature Min</b>	<b>Invalid Maintain Temperature Max</b>
<b>Alarm Condition</b>	(Limiter RTD Open/Short <sup>1</sup> )	(Controller Maintain Temperature Value < Min Maintain Temperature value in °F / °C)	(Controller Maintain Temperature Value > Max Maintain Temperature value in °F / °C)
<b>Action</b>	De-Energize/Energize Control Relay and Raise Alarm	De-Energize Control Relay and Raise Alarm	De-Energize Control Relay, Limiter Relay and Raise Alarm
<b>Control Relay</b>	No Action	De-Energized	De-Energized
<b>Limiter Relay</b>	De-Energized	No Action	De-Energized
<b>Alarm Relay</b>	De- Energized	De-Energized	De-Energized
<b>Alarm Code</b>	0x31	0x41	0x42

<b>Alarm LED (Flash, Delay(s))</b>	(3, one)	(4, one)	(4, two)
<b>Self- Resettable Function &amp; Condition</b>	Yes (Sensor Repaired)	Yes (Correct Maintain Temperature value)	Yes (Correct Maintain Temperature value)
	<b>Invalid High Temperature Trip 1 Min</b>	<b>Invalid High Temperature Trip 1 Max</b>	<b>Invalid High Temperature Trip 2</b>
<b>Alarm Condition</b>	(Limiter High Temperature Trip Value < Min High Temperature Trip value in °F / °C)	(Limiter High Temperature Trip Value > Max High Temperature Trip value in °F / °C)	(Limiter High Temperature Trip Value < Maintain Temperature Value)
<b>Action</b>	De-Energize Limiter Relay and Raise Alarm	De-Energize Control Relay, Limiter Relay and Raise Alarm	De-Energize Control Relay, Limiter Relay and Raise Alarm
<b>Control Relay</b>	No Action	De-Energized	De-Energized
<b>Limiter Relay</b>	De-Energized	De-Energized	De-Energized
<b>Alarm Relay</b>	De-Energized	De-Energized	De-Energized
<b>Alarm Code</b>	0x51	0x52	0x61
<b>Alarm LED (Flash, Delay(s))</b>	(5, one)	(5, two)	(6, one)
<b>Self- Resettable Function &amp; Condition</b>	Yes (Correct High Temperature Trip value)	Yes (Correct High Temperature Trip value)	Yes (Correct Maintain Temperature value)

	<b>Low Temperature Alarm</b>	<b>High Temperature Trip Internal</b>	<b>High Temperature Trip Limiter</b>
<b>Alarm Condition</b>	(Controller Sensor Temperature < (Controller Maintain Temperature Value - Low Temperature Alarm offset value)	(Internal NTC Temperature ≥ Max Internal Circuit Temperature Threshold value)	(Limiter Sensor Temperature ≥ Limiter Maintain Temperature)
<b>Action</b>	Raise Alarm (Control Relay already De-Energized)	De-Energize Control Relay, Limiter Relay and Raise Alarm	De-Energize Limiter Relay and Raise Alarm
<b>Control Relay</b>	Already Energized	De-Energized	De-Energized
<b>Limiter Relay</b>	No Action	De-Energized	De-Energized
<b>Alarm Relay</b>	De- Energized	De-Energized	De-Energized
<b>Alarm Code</b>	0x72	0x81	0x82
<b>Alarm LED (Flash, Delay(s))</b>	(7, two)	(8, one)	(8, two)
<b>Self-Resettable Function &amp; Condition</b>	Yes (Sensor Temperature in differential range)	Yes (Safe internal circuit temperature)	Yes (Auto/Manual Reset OR Module Resets) AND (Limiter RTD Temperature = Limiter High Temperature Trip Value)
	<b>Low Voltage Trip</b>	<b>Hardware Shutdown</b>	
<b>Alarm Condition</b>	(Mains Supply < 204 Vac / 188 Vac / 102	Internal Circuit Temperature ≥	

	Vac) <sup>2</sup>	212°F / 100°C	
<b>Action</b>	De-Energize Control Relay, Limiter Relay and Raise Alarm	ECM will shut down and may be damaged permanently, Alarm Raised (fail safe)	
<b>Control Relay</b>	De-Energized	De-Energized	
<b>Limiter Relay</b>	De-Energized	De-Energized	
<b>Alarm Relay</b>	De-Energized	De-Energized	
<b>Alarm Code</b>	0x92	-----	
<b>Alarm LED (Flash, Delay(s,))</b>	-----	-----	
<b>Self Resettable Function &amp; Condition</b>	Yes (Mains Supply = 204 Vac / 188 Vac / 102 Vac)	No	

<sup>1</sup> Occasionally open circuit and short circuit conditions of the RTD can be mixed.

<sup>2</sup> The Alarm code will be logged in the microprocessor memory once the module powers up again. This fault indicates that the ECM has gone through a power cycle.

\*If the System Alarm is detected by the Controller microcontroller then the Controller Relay will be De-energized along with the Alarm Relay. If system Alarm is detected by the Limiter microcontroller then the Limiter Relay will be De-energized along with the Alarm Relay.

# 8 The ECM RS485 Communication

The ECM is standardly provided with an RS485 communications port. This port allows for communication through Modbus RTU protocol to a PC workstation and/or to the facility distributed control system (DCS). Through this communication link, most of the operating parameters which are programmable at the module can be accessible at the central PC workstation, DCS system console, or other mobile interface devices.

For communications linking information between the ECM and a PC workstation, refer to the TraceView™ Network Explorer Operating Guide, PN 80512.

For communications linking information between the ECM and a DCS or other network modules, refer to the ECM DCS Guide, PN 50315\_0314.

# 9 Installation Requirements

The following are ECM installation requirements:

- Supply wiring shall be sized appropriately to adequately handle amperage requirements of the heat tracing circuits being controlled. Supply wire is limited in size from 20 to 6 AWG (0.5 mm<sup>2</sup> to 16 mm<sup>2</sup>). Wire insulation shall be able to withstand up to 194°F (90°C) operating and exposure temperatures.
- The maximum wire size to the communication and alarm terminals is 16 AWG (1.5 mm<sup>2</sup>)
- The power rating of the section of trace heater within the Terminator enclosure must not exceed 20 W per foot (65.6 W per meter).
- Ground/earth leakage (EPD) breakers must be installed on all circuits. The breakers shall be suitably located so that they are easily accessed, and must be marked as the disconnecting device for the circuit(s) and ECM.
- To avoid static discharge, only clean the ECM with a damp cloth. If the interior of the ECM must be cleaned, ensure that the circuit is completely de-energized prior to attempting to clean.
- If the ECM is used or installed in such a manner that is contrary to this Operating Guide or other Installation Instructions provided by Thermon, the heat tracing circuit control provided by the ECM may be impaired.



# 10 Interpreting the Flash Sequence of the Alarm LED

All the ECM modules are designed to detect various potential alarms which can arise due to different reasons, such as RTD sensor malfunction, operator or installation error, and microprocessor/software alarm events. If an Alarm is detected, it is logged into the internal memory (EEPROM) of the microprocessor along with the time when the Alarm was detected. The EEPROM is able to store the last 20 Alarms detected by the ECM. The user can communicate with the module using RS485 or CAN Bus to request the current Alarms remotely for troubleshooting purposes.

A complete list of the alarm codes for all the ECM types is given in their respective sections of this Guide.

Every Alarm detected by the ECM is given a distinctive hexadecimal code which also determines the flashing sequence for the Alarm LED. The user can determine an Alarm code from the flashing sequence of the Alarm LED and by looking at the Alarm table for the respective ECM module. An example of determining the Alarm from the LED flashing sequence is given in next section.

In the ECM-CL, Controller Alarms are given priority over Limiter Alarms when displayed using the Alarm LED. When no Controller Alarm is present, Limiter Alarms will be displayed using the Alarm LED. Prioritization of the Alarm LED flashing sequence for different ECM modules is summarized in the following table.

Module	Priority for the Alarm LED
ECM-C/ECM-CH	Controller Alarms
ECM-CL	Controller Alarms. When no Controller Alarms or Limiter Alarms are given priority.

<sup>1</sup> Please note this is the operational time of the module under power.

## Alarm LED flashing sequence

The red Alarm LED is used to indicate an Alarm detected by the ECM. The user can look at the Alarm LED and, from the flash sequence and the delay between flash cycles, determine the cause of the alarm event.

**Flash Cycle:** The flash cycle is the number of times the Alarm LED flashes consecutively, with each flash being 0.25 seconds apart.

**Flash Cycle Delay:** The delay between one flash cycle of the Alarm LED and the next, in multiples of one second.

An example for determining an Alarm from the flashing sequence of the Alarm LED is given below:

<p><b>ECM Module Type = ECM-CL</b></p> <p>Number of consecutive LED Flashes in one Flash Cycle = 7</p> <p>Delay between each Flash cycle = 2 second</p>
<p><b>Alarm Code = 0x<math>N_2N_1</math></b></p> <p><b><math>N_2</math></b> = Number of LED Flashes = 7</p> <p><b><math>N_1</math></b> = Flash Cycle Delay = 2</p> <p><b>Alarm Code = 0x72</b></p> <p>From the ECM-CL alarm code list, it can be determined that the High Temperature Alarm was raised by the controller.</p>

# 11 Further Information

For information not covered in this Operators Guide, contact your nearest Thermon engineering support location or Product Support at 1(800)820-4328 for additional assistance.

# Appendix A: ECM

## Factory Default Settings and Ranges

Description	Min	Max	Default	Units
High Temperature Trip Value for Internal Thermistor	32°F / 0°C	185°F / 85°C	185°F / 85°C	°F / °C
Temperature Differential Type	Temperature Offset	%	Temperature Offset	°F / °C
Control/Limiter Temperature Control Band	5°F / 3°C	212°F / 100°C	5°F / 3°C	°F / °C / %
Low Temperature Alarm Offset value	5°F / 3°C	212°F / 100°C	5°F / 3°C	°F / °C / %
High Temperature Alarm Offset value	5°F / 3°C	212°F / 100°C	18°F / 10°C	°F / °C / %
Control/Limiter Relay ON Delay	0	60	5	Seconds
Control/Limiter Relay OFF Delay	0	60	5	Seconds
Alarm Relay ON Delay	0	60	10	Seconds
Alarm Relay OFF Delay	0	60	5	Seconds
Control RTD Open Circuit (Action on Control Relay) <sup>1</sup>	0	1	0	None
Control RTD Short Circuit (Action on Control Relay) <sup>1</sup>	0	1	0	None
4-mA Scaling Temperature	32°F / 0°C	932°F / 500°C	32°F / 0°C	°F / °C
20-mA Scaling Temperature	32°F / 0°C	932°F / 500°C	932°F / 500°C	°F / °C

<sup>1</sup> Only Available in ECM-CL



Thermon, Inc.  
100 Thermon Drive  
San Marcos Texas  
[www.thermon.com](http://www.thermon.com)

Thermon PN 50314U-0721