



# PRODUCT DATASHEET

# GENESIS DUO™

## DUAL-POINT CONTROL AND MONITORING SOLUTION

### APPLICATION



Genesis Duo is Thermon's industry leading IIoT enabled heat trace temperature controller and high temperature limiter. The Duo provides control and monitoring capabilities for one or two heat tracing circuits with input from up to two intrinsically safe RTDs per circuit. The unit can be configured to control

and limit with dedicated intrinsically safe RTD inputs for the limiter channel. Genesis Duo has a 4.3" glove touch capable LCD display with an additional light ring for visual indication. Genesis Duo is also native to the Genesis Network requiring no additional hardware to communicate with Thermon's state of the art supervisory and management platform.

### GENESIS NETWORK

The Thermon *Genesis Network* consists of a control room server, a gateway, and a collection of field deployed bridges/nodes that form a wireless mesh communications network. Alternatively, the network can be made via a traditional wired Ethernet network. The *Genesis Network* connects all heat trace panels and controllers to the control room and gives visibility of all assets from a single dashboard and user interface that can be accessed from any browser.

### PRODUCT FEATURES

A Genesis Duo control and monitoring unit offers the following features:

**Efficient Configuration and Operation:** With the glove touch enabled 4.3" LCD operators can quickly program the Genesis Duo and access all readings. The touch interface is extremely intuitive and requires little training to get up and running. When the Duo is connected to Genesis Network configuration and operation can be done from a centralized location to enable a distributed controls network.

**Light Ring Notifications:** The Duo is equipped with a notification light ring that signals the operator using color and motion to convey alarm and notification states.

**Upgraded Communications:** The Duo is Genesis Network native with the built in wireless mesh or wired ethernet. The Duo can also optionally be connected directly to any plant DCS system via Modbus TCP or Modbus RTU. Modbus Memory maps are compatible with the TCM2 controller to enable a drop in replacement option.

**High Temperature Limiter:** The Duo has the ability to be configured as a single channel with a high temperature limiter. The high temperature limiter functionality is isolated and has dedicated RTD inputs. The Duo when enabled with the limiter function meets the requirements of IEC/EN/UL/CSA 60079-30-1 for controlled design to limit energy to the heat trace in explosive atmospheres.

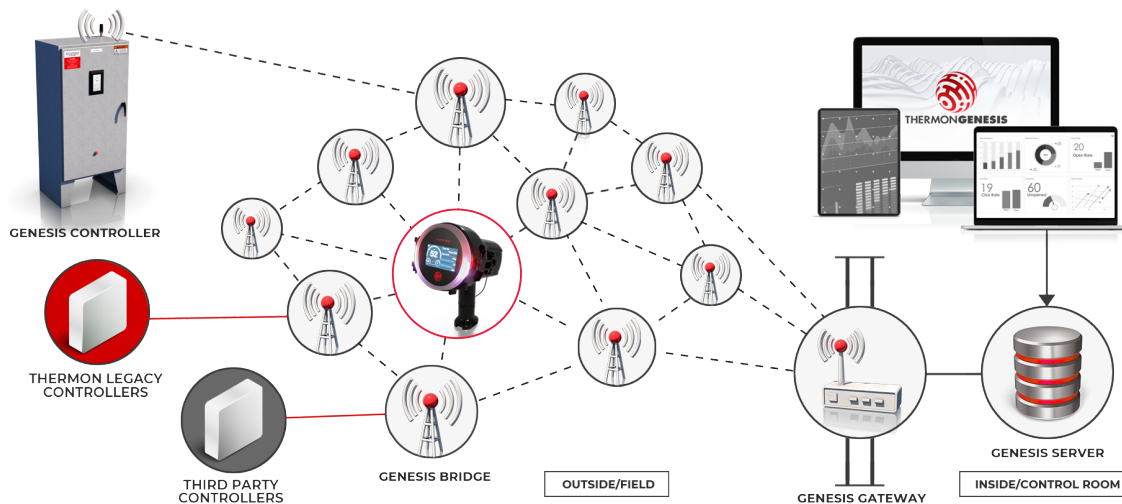



**PRODUCT DATASHEET**  
**GENESIS DUO™**  
**DUAL-POINT CONTROL AND MONITORING SOLUTION**

**ORDERING INFORMATION**

Part Number	Model Code	Description
816011	GN-D-S-S-T-C-Z-XP	Genesis Duo w/ LCD, Current Monitoring (2 SSR) - Pipe Mount
816012	GN-D-S-S-T-C-Z-WP	Genesis Duo w/ LCD, Current Monitoring (2 SSR) - Wall Mount
816021	GN-D-M-M-0-0-Z-XP	Genesis Duo w/o LCD (2 Mechanical) - Pipe Mount
816022	GN-D-M-M-0-0-Z-WP	Genesis Duo w/o LCD (2 Mechanical) - Wall Mount

**RATINGS**

CONTROL AND MONITORING CAPACITY	2 HEAT TRACING CIRCUITS
SUPPLY AND LOAD VOLTAGES	100-277 V~, 50/60 HZ
MAXIMUM INPUT CURRENT	1.5 A
FUSE RATING	3.15 A
HEATER OUTPUTS (EACH CIRCUIT INDEPENDENTLY POWERED AND SWITCHED)	
INPUT VOLTAGE	100-277 V~, 50/60 HZ
OUTPUT CURRENT (SEE DERATING)	30 A~
GROUND FAULT MEASUREMENT	UP TO 500 MA
HEATER CURRENT MEASUREMENT	UP TO 60 A
VOLTAGE MEASUREMENT (FOR POWER CALCULATION)	UP TO 277 V
POWER CLAMP FUNCTION	PROGRAMMABLE FROM 20%-100%
TEMPERATURE INPUT	UP TO TWO, 3-WIRE PLATINUM 100 OHM RTDS PER CIRCUIT
TEMPERATURE CONTROL RANGE	-40°C TO 600°C (-40°F TO 1112°F)
CONTROL BAND	PROGRAMMABLE IN INCREMENTS OF 1 DEGREE
DRY CONTACT ALARM RELAY	TWO 277 V~, 500 MA OR HIGHER
AUX INPUT	CONTACT CLOSURE SENSED
SELF-TEST FREQUENCY	PROGRAMMABLE FROM 2 TO 99 HOURS
COMMUNICATION	
WIRED	RS-485 (MODBUS RTU) ETHERNET (BACKHAUL)
WIRELESS	MESH VIA 802.15.4 RADIO
AUXILIARY POWER OUTPUT	9 W @ 24 VDC
POLLUTION DEGREE	2
DEGREE OF PROTECTION AND TYPE RATING	IP66, TYPE 4
OPERATING TEMPERATURE RANGE	-40°C TO +60°C @ 25A -40°C TO +55°C @ 30A
STORAGE TEMPERATURE RANGE	-40°C TO +85°C

**PRODUCT DIMENSIONS**

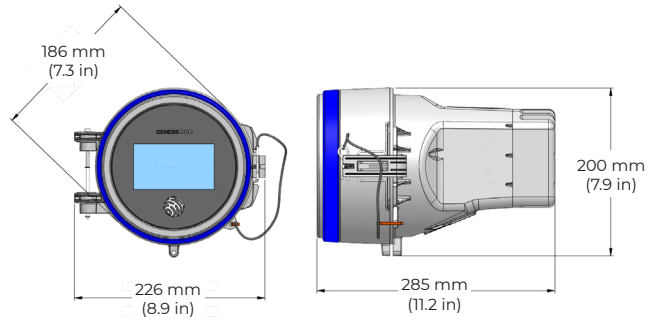

**CERTIFICATIONS/APPROVALS**



-40°C ≤ Tamb ≤ +60°C; IP66  
 Class I, Zone 2, AEx/Ex ec mc nC [ib Gb] IIC T4 Gc  
 Zone 22, AEx/Ex tc IIIC T135°C  
 Class I, Division 2, Groups A,B,C,D; T4  
 Class II, Division 2, Groups FG; Class III; T135°C  
 Ex ec mc nC [ib Gb] IIC T4 Gc  
 Ex tc IIIC T135°C Dc  
 II 3(2) G Ex ec mc nC [ib Gb] IIC T4 Gc  
 II 3 D Ex tc IIIC 135°C Dc