

Terminator™ ZT-MI-WP

Thermostat Connection Kit

INSTALLATION PROCEDURES



For Thermostat Connection (1-2 Heating Cables) Applications
For Use With MI Mineral Insulated Heating Cable Sets



The Heat Tracing Specialists®

Terminator™ ZT-MI-WP

INSTALLATION PROCEDURES

The following installation procedures are suggested guidelines for the installation of the Terminator ZT-MI-WP Kit.

Receiving, Storing and Handling . . .

1. Inspect materials for damage incurred during shipping.
2. Report damages to the carrier for settlement.
3. Identify parts against the packing list to ensure the proper type and quantity has been received.
4. Store in dry location.

Kit Contents . . .



Wire Pins (per MI cable cold lead, order separately)

Item	Quantity	Description						
1	1	Expediter Assembly Support Cap with O-Ring Threaded Grommet Compressor Grommet Support Base with O-Ring						
2	1	Junction Box Lid						
3	1	Junction Box Base with O-Ring and M25 Dust Cap						
4	1	Nut						
5	1	Banding						
6	1	Thermostat w/ Terminal Blocks <small>(Refer to terminal specifications for maximum allowable wire size)</small> <table border="0" style="width: 100%; border-collapse: collapse;"> <tr> <td style="width: 50%;"><u>Thermostat Type</u></td> <td style="width: 50%;"><u>Control Range</u></td> </tr> <tr> <td>ZT-C-300</td> <td>0°C to +300°C</td> </tr> <tr> <td>ZT-C-500</td> <td>20°C to +500°C</td> </tr> </table>	<u>Thermostat Type</u>	<u>Control Range</u>	ZT-C-300	0°C to +300°C	ZT-C-500	20°C to +500°C
<u>Thermostat Type</u>	<u>Control Range</u>							
ZT-C-300	0°C to +300°C							
ZT-C-500	20°C to +500°C							
7	1	Capillary Armouring w/ Glands						
8	1	Junction Box Cord						
9	2	Blind Plug M20						
10	1	Bracket						
11	3	Screws						
12	3	Washers						
13	4	Wire Pins						

Dimensions . . .

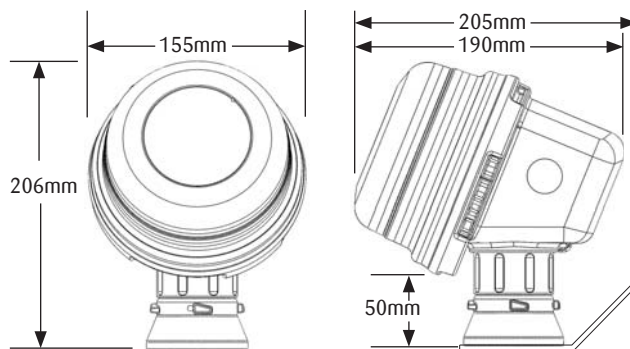

Warnings . . .

- Due to the risk of electrical shock, arcing and fire caused by product damage or improper usage, installation or maintenance, a ground-fault protection device is required.
- Installation must comply with Thermon requirements (including form PN 50273U for Ex systems) and be installed in accordance with the regulations as per the norm EN IEC 60079-14 for hazardous areas (where applicable), or any other applicable national and local codes.
- Component approvals and performance ratings are based on the use of Thermon specified parts only.
- De-energize all power sources before opening enclosure.
- Avoid electrostatic charge. Clean only with a damp cloth.
- Keep ends of heating cable and kit components dry before and during installation.
- Minimum bending radius of heating cable is 6 times the cable outer diameter.
- Individuals installing these products are responsible for complying with all applicable safety and health guidelines. Proper Personal Protective Equipment (PPE) should be utilized during installation. Contact Thermon if you have any additional questions.

Tools Required . . .

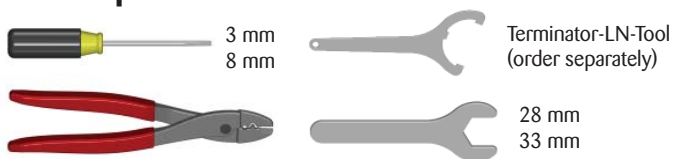

Certifications/Approvals . . .

IP66 -60°C ≤ Ta ≤ +50°C T5, 100°C; -60°C ≤ Ta ≤ +40°C T6, 85°C
Ordinary & Hazardous Locations

FMG 10.0022X Ex db eb IIC T5-T6, Ex tb IIIC T100°C-T85°C

1725 II 2 GD Ex db eb IIC T5-T6, Ex tb IIIC T100°C-T85°C FM 10ATEX0058X

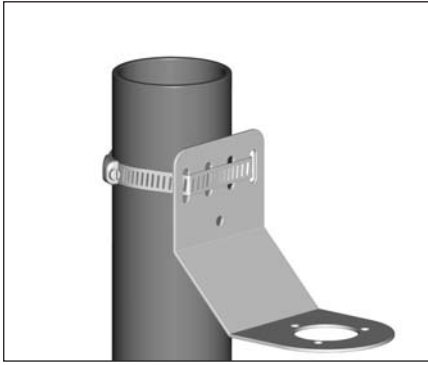

1a. Mounting Method 1: Secure wall mount bracket to mounting surface using pipe band provided with kits.

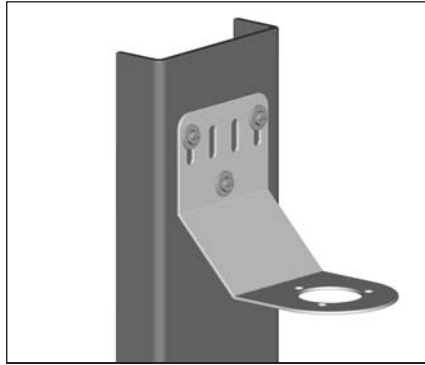

1b. Mounting Method 2: Secure wall mount bracket to mounting surface using customer supplied screws, flat washers, and nuts.

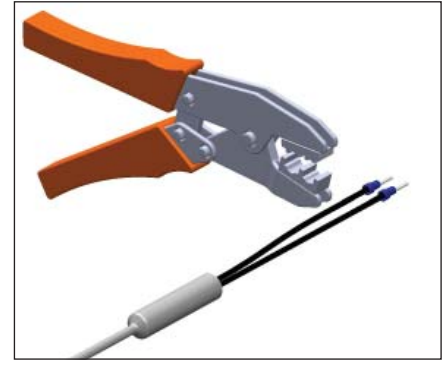

2. Crimp appropriate wire pins (2.5 mm² or 6 mm²) on MI cable cold lead wires.

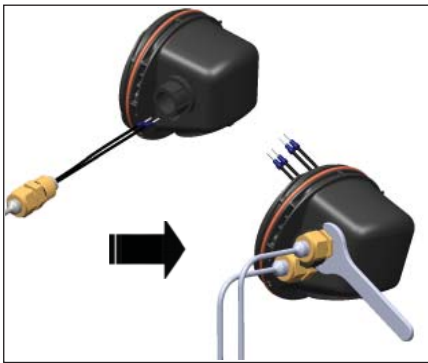

3. Route MI cable cold leads through M20 threaded entries. Screw cable glands into junction box.



Do not overtighten to ensure o-ring is not damaged during installation.

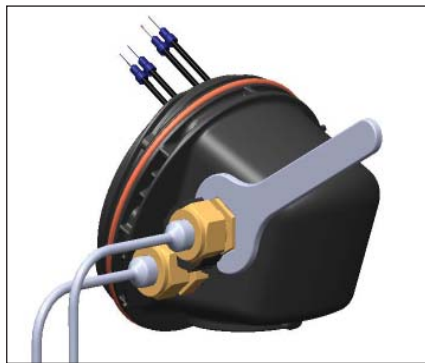

4. Center cold lead sleeve inside cable gland. Tighten cable glands until ferrule begins to make contact with cold lead sleeve and cold lead sleeve cannot be moved by hand. Tighten cable gland 1/8 additional turn or to a torque value of 16 Nm (142 lb-in).

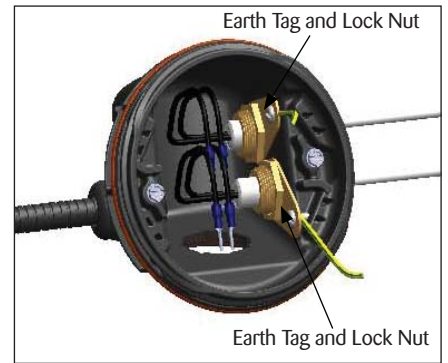

5. Install user supplied M20 Earth Tag and Lock Nut to threaded M20 Gland.

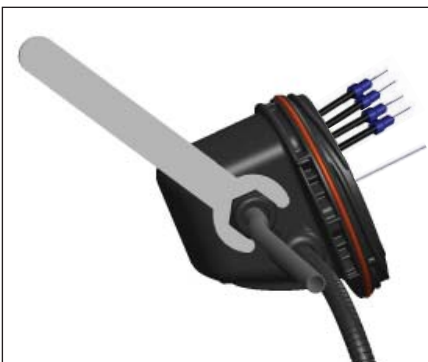

6. Remove M25 dust cap. Install M25 power gland (customer supplied) in M25 threaded entry.

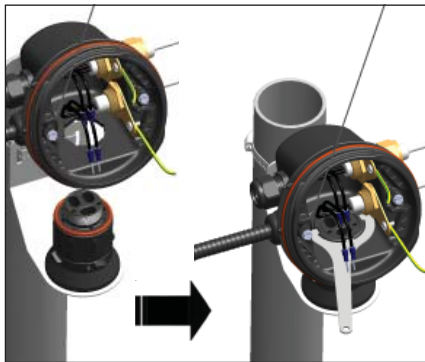

7. Mount junction box base on expediter. Make sure to align slots to properly orient junction box base. Tighten nut with Terminator-LN-Tool. If mounting horizontally, threaded gland holes must face downward.

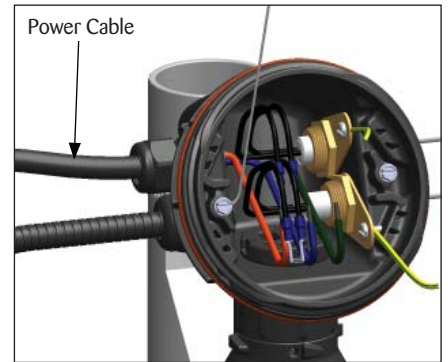

8. Install power cable (if necessary).

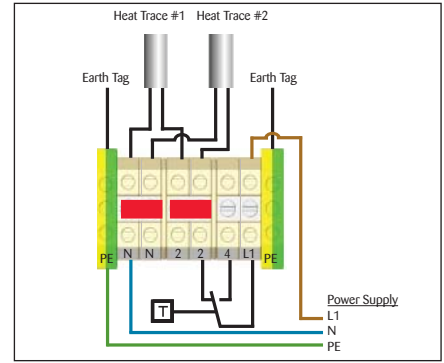
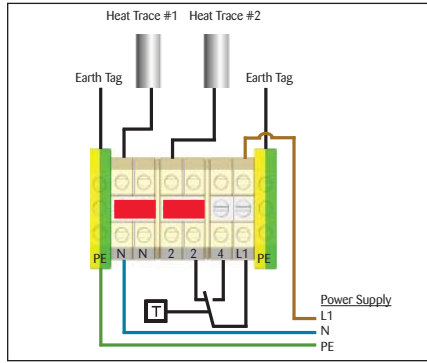
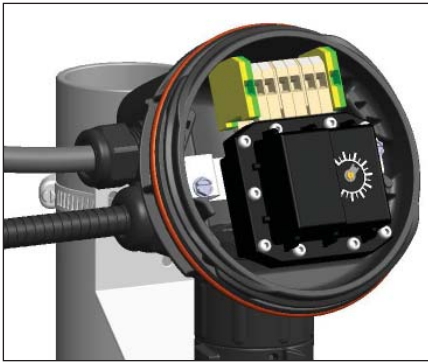

9. Install thermostat and complete system wiring. Terminal set screws shall be tightened to a torque value of 1.4 Nm (12.4 lb-in). See wiring diagrams for details. Set thermostat at desired setpoint.

Wiring Details: Single Core

Wiring Details: Dual Core



10. Install junction box lid and twist hand tight. Insert screwdriver into ratchet slots located on side of junction box base. Use screwdriver to ratchet on junction box lid. Lid will rotate 30 degrees. To remove lid, repeat steps in the opposite direction.



11. Fix thermostat bulb and capillary tube to pipe.

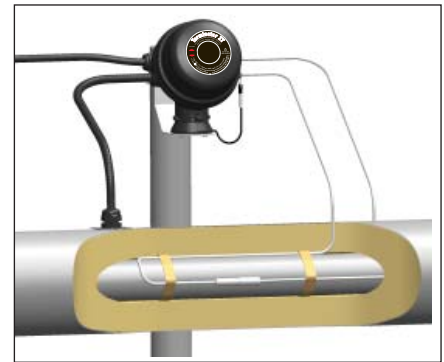

12. Seal penetration through insulation cladding.



THERMON . . . The Heat Tracing Specialists®
www.thermon.com

European Headquarters
Boezemweg 25 • PO Box 205
2640 AE Pijnacker • The Netherlands
Phone: +31 (0) 15-36 15 370

Corporate Headquarters
100 Thermon Dr. • PO Box 609
San Marcos, TX 78667-0609 • USA
Phone: +1 512-396-5801

For the Thermon office nearest you
visit us at . . .
www.thermon.com



Specifications and information are subject to change without notice. Form PN50855U-0113