

# 360°

## Schoeller Allibert Returnable Plastic Packaging Solutions

➤ Retail



**Schoeller Allibert**

Innovating your logistics for a better world

# Since 1976, Schoeller Allibert is the leading supplier of Reusable Transit Packaging (RTP) to the retail sector

Schoeller Allibert manufacture a vast range of products to help the retail supply chain reduce transit packaging costs, speed handling, picking & in-store replenishment operations, prevent theft and protect products from damage.

## Unique and innovative plastic packaging solutions enhancing sustainability

Our logistics packaging solutions are tough and reusable, enabling our customers to save energy, reduce their environmental impact and increase profitability.

Our teams are dedicated to innovation, worldwide. Anticipating our 7 market leader needs, we design and offer future-proof solutions for industries as diverse as Automotive, Agriculture, Retail, Food processing, Industrial Manufacturing, Beverage and Pooling.

We are striving to help our customers to move towards the "circular economy" by inventing and manufacturing packaging with the minimum quantity of material for a maximised service life. We offer our EFSA approved recycling services to optimise resource use and reuse, avoiding waste and maximising economic value of your initial investment in our packaging.

## Our 360° approach

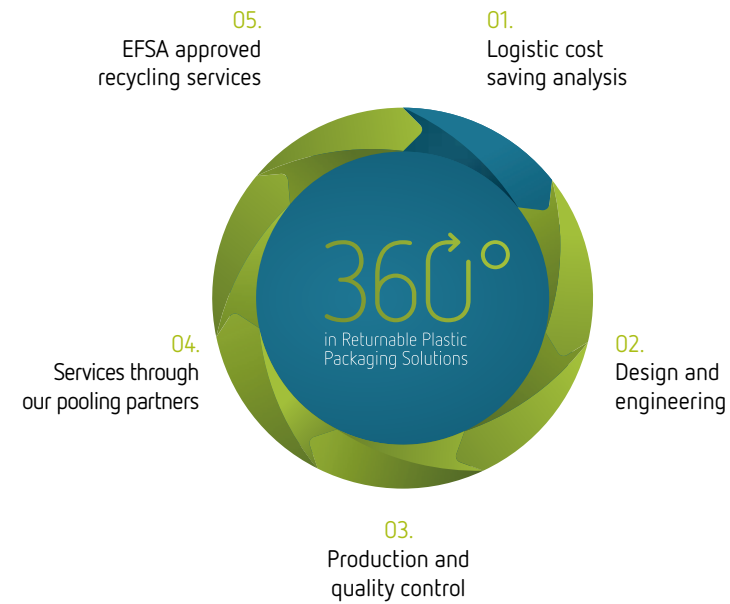

See our online brochure for more details visit our website [www.schoellerallibert.com](http://www.schoellerallibert.com)

## Table of contents

- 01. Table of contents
- 02. Introduction
- 04. Foldable Large Containers
- 05. Rigid Pallet Containers
- 06. Plastic Pallets
- 08. Stack/Nest Containers
- 13. Stackable Containers
- 14. Foldable Small Containers
- 16. Dollies
- 17. Mission statement & recycling

## 42 years of innovative solutions for retail

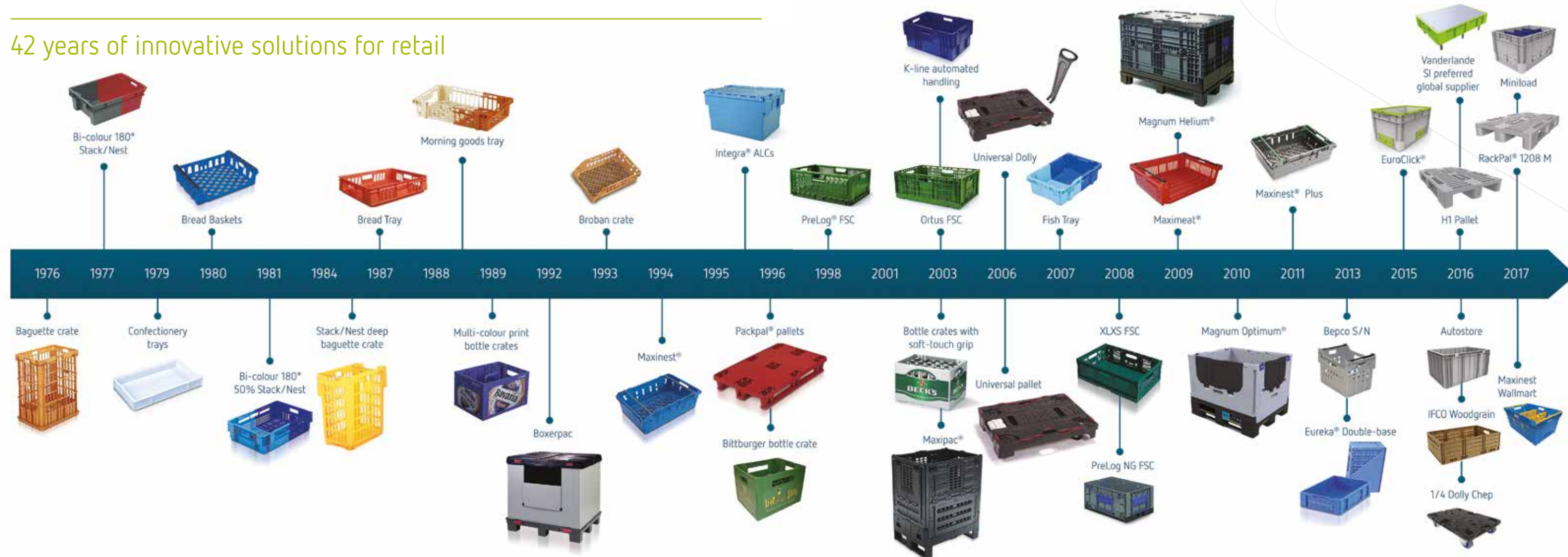

# Since 1976, Schoeller Allibert is the leading supplier of Reusable Transit Packaging (RTP) to the retail sector

Schoeller Allibert manufacture a vast range of products to help the retail supply chain reduce transit packaging costs, speed handling, picking & in-store replenishment operations, prevent theft and protect products from damage.

## Packaging solutions for retail

Schoeller Allibert reusable packaging units perform numerous delivery cycles over many years and, at the end of their working life, are fully recyclable.

Foldable or nestable units avoid the waste of time and money associated with storing and moving 'air' on return journeys. Schoeller Allibert RTP helps customers to speed order picking and in-store stock replenishment operations while protecting products from damage and theft while in transit. Printed with owners logo and manufactured in corporate colours it can also provide a valuable marketing function.

### Food and grocery retail

For hyper and supermarkets, convenience stores and home delivery. Reusable Transit Packaging (RTP) is used at every stage of the supply chain: from harvesting of fresh produce, fish boxing at sea, meat portioning at slaughterhouses, maturing cheese, etc. All the way through the supply chain to retail point-of-sale display.

Schoeller Allibert trays, crates, pallets and bulk containers promote the quality & longevity of fresh produce, bakery, meat, fish and dairy products while improving distribution efficiencies, speeding in-store stock replenishment and reducing packaging waste.



### Non-food retail packaging solutions

Schoeller Allibert manufacture RTP solutions for both traditional non food retail supply chains and the growing e-commerce channel.

For distribution from supplier to retail distribution centre and onward delivery to store; Schoeller Allibert reusable packaging solutions protect contents from damage, deter theft and reduce handling and distribution costs.

Typical non-food applications include clothing, soft furnishings, DIY, return logistics, electronic goods, etc.

The growth in online shopping for home delivery and drive, click and collect, is resulting in new fully automated warehouses.

Schoeller Allibert manufacture a wide range of crates that are compatible with automated storage & retrieval systems (ASRS), conveyors, scanning equipment, etc.



### New : Drive/click and collect retail channel

The first «drive-in retail» was introduced in France in 2004. Today all French grocery retailers have opened «drive through» locations either stand-alone or attached to a store. This channel is spreading through Europe and the USA along with the «click and collect» services now available at most food and non-food retail chains.

For this application Schoeller Allibert has designed an extra deep Maxinest® and linkable dollies that are the most popular and efficient solution for handling different goods during order preparation.

With this global logistics solution Schoeller Allibert helps retailers improving efficiency and speed of order preparation for all types of click and collect organizations.



Schoeller Allibert  
Innovating your logistics for a better world



## Versions



A Solid base



N Solid sliding door on sides

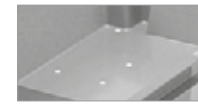

B Solid base with drainage holes



O Ventilated door on sides

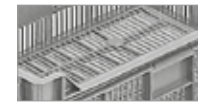

C Ventilated base



P Ventilated door on ends



D Solid walls



Q 4 feet

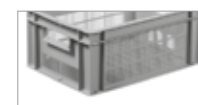

E Ventilated walls



R 6 feet



F Ventilated sides + solid ends



S 9 feet

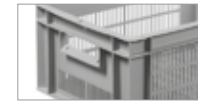

G 2 open handholes



T 2 skids



H 4 open handholes



U 3 skids



I Reinforced ribbed base



V 6 skids



J Reinforced smooth base



W Solid deck



K Integrated label holder



X Ventilated deck



L Solid drop door on 1 side



Y 4 castor wheels



M Solid drop door on 1 end



Z 2 fixed and 2 castor wheels

## Foldable Large Containers | Magnum

From lightweight to heavy duty, available in 3 standard footprints, our foldable large containers have been especially developed for long distances and a large number of return trips, maximizing cost saving and lowering carbon footprint.



Discover more in our foldable large containers brochure

### 800 x 600



2640.610 - 212 L

Ext. (mm) 800 x 600 x 680  
Int. (mm) 740 x 540 x 530  
Weight (Kg) 18.0  
Folded height (mm) 373  
Stacked height (mm) 660  
Unit load (Kg) 700  
Stack load (Kg) 2100  
Dynamic load (Kg) 700  
Version B / D / L(2) / T



2630.633 - 274 L - Pally Magnum

Ext. (mm) 800 x 600 x 910  
Int. (mm) 740 x 540 x 685  
Weight (Kg) 30.0  
Folded height (mm) 430  
Stacked height (mm) 870  
Unit load (Kg) 250  
Stack load (Kg) 2000\*  
Dynamic load (Kg) 250  
Version B / D / L(2) / T / Z

\*Stack only with a lid on

### 1200 x 800



2570.400 - 528 L - Magnum Helium®

Ext. (mm) 1200 x 800 x 830  
Int. (mm) 1130 x 725 x 645  
Weight (Kg) 27.0  
Folded height (mm) 295  
Stacked height (mm) 814  
Unit load (Kg) 200  
Stack load (Kg) 450  
Dynamic load (Kg) 450  
Version B / D / L / S

Lid included.

### 1200 x 1000



2540.652 - 605 L - Magnum Optimum®

Ext. (mm) 1200 x 1000 x 750  
Int. (mm) 1140 x 940 x 565  
Weight (Kg) 42.0  
Folded height (mm) 295  
Stacked height (mm) 720  
Unit load (Kg) 750  
Stack load (Kg) 3200  
Dynamic load (Kg) 1600  
Version B / D / K / N / T



9142.092 - 357 L - Maxipac®

Ext. (mm) 800 x 600 x 1080  
Int. (mm) 756 x 556 x 843  
Weight (Kg) 25.5  
Folded height (mm) 420  
Stacked height (mm) 1040  
Unit load (Kg) 250  
Stack load (Kg) 750  
Dynamic load (Kg) 500  
Version B / E / O / P / Y

Ref. 9507.092 2 skids version.



2636.820 - Lid

Ext. (mm) 809 x 609 x 91  
Weight (Kg) 1.8  
Version W



9437.099 - 600 L - Boxerpac®

Ext. (mm) 1200 x 800 x 910  
Int. (mm) 1140 x 740 x 710  
Weight (Kg) 28.0  
Folded height (mm) 262  
Stacked height (mm) 900  
Unit load (Kg) 500  
Stack load (Kg) 1500  
Dynamic load (Kg) 500  
Version B / D / L(2) / S

Lid included / Ref. 9438.000 2 skids version.



2549.461 - 847 L - Magnum Optimum®

Ext. (mm) 1200 x 1000 x 975  
Int. (mm) 1140 x 940 x 790  
Weight (Kg) 51.0  
Folded height (mm) 295  
Stacked height (mm) 945  
Unit load (Kg) 750  
Stack load (Kg) 3200  
Dynamic load (Kg) 1600  
Version B / D / K / L / M / T

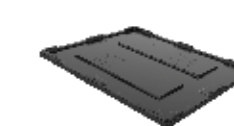

9347.000 - Lid

Ext. (mm) 1220 x 1020 x 50  
Weight (Kg) 5.2  
Version W

Lid for Magnum Optimum® range.

## Rigid Pallet Containers | MaxiFlow®

Hygienic, strong and stable, our MaxiLog®, Agrilog® and Big Box ranges offer a robust storage and shipping sustainable packaging system. Our Rigid Pallet Containers are ideal for heavy-duty distribution applications and are automation-friendly. They improve space efficiency and optimize truckload.



Discover more in our rigid pallet containers brochure

### 1200 x 1000

#### Bigbox



8450.300 - 600 L

Ext. (mm) 1200 x 1000 x 760  
Int. (mm) 1120 x 920 x 560  
Weight (Kg) 44.7  
Stacked height (mm) 730  
Unit load (Kg) 500  
Stack load (Kg) 4500  
Version A / D / U



4429.300 - 610 L - MaxiLog®

Ext. (mm) 1200 x 1000 x 760  
Int. (mm) 1108 x 908 x 600  
Weight (Kg) 36.8  
Stacked height (mm) 734  
Unit load (Kg) 450  
Stack load (Kg) 4500  
Version A / D / U

Ref. 4429.600 ventilated version.



4429.200 - 610 L - MaxiLog®

Ext. (mm) 1200 x 1000 x 760  
Int. (mm) 1108 x 908 x 600  
Weight (Kg) 34.5  
Stacked height (mm) 734  
Unit load (Kg) 450  
Stack load (Kg) 4500  
Version A / D / T

Ref. 4429.500 ventilated version.



4429.100 - 610 L - MaxiLog®

Ext. (mm) 1200 x 1000 x 760  
Int. (mm) 1108 x 908 x 600  
Weight (Kg) 32.4  
Stacked height (mm) 734  
Unit load (Kg) 450  
Stack load (Kg) 4500  
Version A / D / Q

Ref. 4429.400 ventilated version.



4401.100 - 620 L

Ext. (mm) 1200 x 1000 x 760  
Int. (mm) 1110 x 910 x 610  
Weight (Kg) 39.5  
Stacked height (mm) 730  
Unit load (Kg) 500  
Stack load (Kg) 4500  
Version A / D / Q



4401.150 - 620 L

Ext. (mm) 1200 x 1000 x 760  
Int. (mm) 1110 x 910 x 610  
Weight (Kg) 39.5  
Stacked height (mm) 730  
Unit load (Kg) 500  
Stack load (Kg) 4500  
Version A / D / L / Q



1732.400 - 670 L

Ext. (mm) 1200 x 1000 x 780  
Int. (mm) 1110 x 910 x 620  
Weight (Kg) 34.1  
Stacked height (mm) 750  
Unit load (Kg) 500  
Stack load (Kg) 4500  
Version C / E / Q



4410.820 - Lid

Ext. (mm) 1212 x 1012 x 79  
Weight (Kg) 7.6  
Version W

Compatible with MaxiLog® and 4401 range.

## Versions



A Solid base



N Solid sliding door on sides

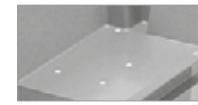

B Solid base with drainage holes



O Ventilated door on sides



C Ventilated base



P Ventilated door on ends



D Solid walls



Q 4 feet



E Ventilated walls



R 6 feet



F Ventilated sides + solid ends



S 9 feet



G 2 open handholes



T 2 skids



H 4 open handholes



U 3 skids



I Reinforced ribbed base



V 6 skids



J Reinforced smooth base



W Solid deck



K Integrated label holder



X Ventilated deck



L Solid drop door on 1 side



Y 4 castor wheels



M Solid drop door on 1 end



Z 2 fixed and 2 castor wheels

## Plastic Pallets | GreenFlow®

Schoeller Allibert offers a wide range of plastic pallets. Our pallets are available in 8 standard footprints and 5 different types to meet all logistics requirements: display, light, medium, heavy duty and clean room models. Durability, profitability, hygiene, safety are our pallets' main benefits.



Discover more in our plastic pallets brochure

### 800 x 600



6100.750  
Ext. (mm) 800 x 600 x 147  
Weight (Kg) 5.0  
Stacked height (mm) 140  
Stack load (Kg) 1000  
Dynamic load (Kg) 500  
Version U / X



9370.004 - Universal Pallet Medium Duty  
Ext. (mm) 800 x 600 x 165  
Weight (Kg) 7.0  
Stacked height (mm) 165  
Stack load (Kg) 1000  
Dynamic load (Kg) 500  
Version U / W



With pop ups.

### 1200 x 800



3303.001 - Lightweight  
Ext. (mm) 1200 x 800 x 150  
Weight (Kg) 8.2  
Nested height (mm) 65  
Stack load (Kg) 2500  
Dynamic load (Kg) 1000  
Version S / X



7842.002 - Heavy Duty H1 Pallet  
Ext. (mm) 1200 x 800 x 167  
Weight (Kg) 18.0  
Stacked height (mm) 160  
Stack load (Kg) 5000  
Dynamic load (Kg) 1250  
Racking load (Kg) 1000  
Version U / X



With safety rim.

With safety rim.



2714.516 - Heavy Duty  
Ext. (mm) 1200 x 800 x 165  
Weight (Kg) 18.5  
Stacked height (mm) 161  
Stack load (Kg) 4500  
Dynamic load (Kg) 1250  
Racking load (Kg) 1000  
Version U / W



9378.000 - Medium Duty Packpal®  
Ext. (mm) 1200 x 800 x 172  
Weight (Kg) 7.8  
Stacked height (mm) 165  
Stack load (Kg) 1500  
Dynamic load (Kg) 1000  
Version U / X



With safety rim.

With safety rim.



9372.000 - Heavy Duty Maestro®  
Ext. (mm) 1200 x 800 x 165  
Weight (Kg) 19.0  
Stacked height (mm) 158  
Stack load (Kg) 1500  
Dynamic load (Kg) 1200  
Racking load (Kg) 1000  
Version U / W



9378.001 - Medium Duty Packpal®  
Ext. (mm) 1200 x 800 x 172  
Weight (Kg) 8.9  
Stacked height (mm) 165  
Stack load (Kg) 1500  
Dynamic load (Kg) 1000  
Version U / W



With safety rim.

With safety rim.

### Foldable Pallet Collar



9420.001 - Pallet collar  
Ext. (mm) 1220 x 820 x 350  
Int. (mm) 1160 x 760 x 300  
Weight (Kg) 6.2  
Version E



9728.001 - Pallet collar  
Ext. (mm) 1220 x 1015 x 350  
Int. (mm) 1160 x 955 x 300  
Weight (Kg) 7.0  
Version E



### 1200 x 800

## RackPal® 1208M: the new Schoeller Allibert medium rackable pallet

#### 1. Outstanding performance

Only 14 kg the Rackpal® pallet can take up to 6 tons static load, 1500 kg dynamic load and 800 kg on racks Compliant to the utmost pallet standards and norms.

#### 2. Designed for automated handling systems

From 800 kg up to 1250 kg racking load, Rackpal® works seamlessly on all robotized handling systems. Silent on conveyors it is available with or without top rim to adapt to all intralogistics devices.

#### 3. The retail e-business and food processing pallet

Perforated top deck for optimum airflow. For high hygiene requirements end uses, welded runners version are available.

#### 4. Ideal for retail logistics

With a 1500 kg dynamic load, Rackpal® is a sturdy pallet designed for harsh logistics environments. Extra features enhance the safety of shipments: horizontal ribbing on feet hold warp foils, and the deck is equipped with 4 strap hook locations.



8380.100 - Medium Duty - RackPal® 1208M  
Ext. (mm) 1200 x 800 x 152  
Weight (Kg) 14.2  
Stacked height (mm) 152  
Stack load (Kg) 6000  
Dynamic load (Kg) 1500  
Racking load (Kg) 800  
Version X / U



8380.200 - Medium Duty - RackPal® 1208M  
Ext. (mm) 1200 x 800 x 159  
Weight (Kg) 14.2  
Stacked height (mm) 152  
Stack load (Kg) 6000  
Dynamic load (Kg) 1500  
Racking load (Kg) 800  
Version X / U



Flat deck.

With safety rim.



8380.110 - Medium Duty - RackPal® 1208M  
Ext. (mm) 1200 x 800 x 152  
Weight (Kg) 15.6  
Stacked height (mm) 152  
Stack load (Kg) 6000  
Dynamic load (Kg) 1500  
Racking load (Kg) 800  
Version X / U



8380.210 - Medium Duty - RackPal® 1208M  
Ext. (mm) 1200 x 800 x 159  
Weight (Kg) 15.6  
Stacked height (mm) 152  
Stack load (Kg) 6000  
Dynamic load (Kg) 1500  
Racking load (Kg) 800  
Version X / U



Flat deck. Smooth welded runners.

With safety rim. Smooth welded runners.



8380.150 - Reinforced deck - RackPal® 1208M  
Ext. (mm) 1200 x 800 x 152  
Weight (Kg) 17.7  
Stacked height (mm) 152  
Stack load (Kg) 6000  
Dynamic load (Kg) 1500  
Racking load (Kg) 1250  
Version X / U



8380.250 - Reinforced deck - RackPal® 1208M  
Ext. (mm) 1200 x 800 x 159  
Weight (Kg) 17.7  
Stacked height (mm) 152  
Stack load (Kg) 6000  
Dynamic load (Kg) 1500  
Racking load (Kg) 1250  
Version X / U



Flat deck.

With safety rim.



8380.160 - Reinforced deck - RackPal® 1208M  
Ext. (mm) 1200 x 800 x 152  
Weight (Kg) 19.5  
Stacked height (mm) 152  
Stack load (Kg) 6000  
Dynamic load (Kg) 1500  
Racking load (Kg) 1250W  
Version X / U



8380.300 - Medium Duty - RackPal® 1208M  
Ext. (mm) 1205 x 805 x 174  
Weight (Kg) 14.4  
Stacked height (mm) 152  
Stack load (Kg) 6000  
Dynamic load (Kg) 1500  
Racking load (Kg) 800  
Version U / X



Flat deck. Smooth welded runners.

With 22 mm safety rim.

### 1200 x 1000



9377.000 - Heavy Duty Maestro®  
Ext. (mm) 1200 x 1000 x 165  
Weight (Kg) 23.5  
Stacked height (mm) 158  
Stack load (Kg) 5000  
Dynamic load (Kg) 1500  
Racking load (Kg) 1200  
Version U / W



9497.000 - Medium Duty Packpal®  
Ext. (mm) 1200 x 1000 x 172  
Weight (Kg) 9.3  
Stacked height (mm) 165  
Stack load (Kg) 1500  
Dynamic load (Kg) 1000  
Version U / X



With safety rim.

With safety rim.

## Versions



A Solid base



N Solid sliding door on sides

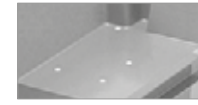

B Solid base with drainage holes



O Ventilated door on sides



C Ventilated base



P Ventilated door on ends



D Solid walls



Q 4 feet



E Ventilated walls



R 6 feet



F Ventilated sides + solid ends



S 9 feet



G 2 open handholes

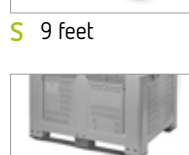

T 2 skids



H 4 open handholes



U 3 skids



I Reinforced ribbed base

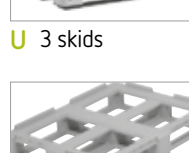

V 6 skids



J Reinforced smooth base



W Solid deck



K Integrated label holder



X Ventilated deck



L Solid drop door on 1 side



Y 4 castor wheels



M Solid drop door on 1 end



Z 2 fixed and 2 castor wheels

## Stack/Nest Containers | EasyNest®

Stack/Nest containers securely stack when loaded and nest when empty to save valuable space on return transport. Ranges include award-winning Maxinest® produce trays, tamper-evident Integra® ALCs (Attached Lid Containers) and bicolour 180°'s for easy visual identification of stack / nest position.



Discover more in our stack/nest containers brochure

### Euro norm with Swings Bars

#### Maxinest® - 400 x 300



9633.002 - 10 L - Maxinest®  
Ext. (mm) 400 x 300 x 135  
Int. (mm) 364 x 264 x 100  
Weight (Kg) 0.82  
Stacked height 127  
Nesting ratio 60.00 %  
Version C / E



9636.002 - 15 L - Maxinest®  
Ext. (mm) 400 x 300 x 180  
Int. (mm) 364 x 264 x 143  
Weight (Kg) 0.97  
Stacked height 172  
Nesting ratio 70.00 %  
Version C / E

#### Maxinest® - 600 x 400



9635.002 - 16 L - Maxinest®  
Ext. (mm) 600 x 400 x 106  
Int. (mm) 552 x 352 x 80  
Weight (Kg) 1.22  
Stacked height 93  
Nesting ratio 62.00 %  
Version C / E



9634.002 - 35 L  
Ext. (mm) 600 x 400 x 199  
Int. (mm) 546 x 347 x 172  
Weight (Kg) 1.9  
Stacked height 186  
Nesting ratio 76.00 %  
Version C / E / G / I



9962.002 - 16 L - Maxinest® Plus  
Ext. (mm) 600 x 400 x 106  
Int. (mm) 552 x 352 x 80  
Weight (Kg) 1.06  
Stacked height 93  
Nesting ratio 62.00 %  
Version C / E / I



9637.002 - 35 L - Maxinest®  
Ext. (mm) 600 x 400 x 199  
Int. (mm) 549 x 350 x 172  
Weight (Kg) 1.62  
Stacked height 186  
Nesting ratio 77.00 %  
Version C / E / G



## Customer story

### Initial Situation:

Sainsbury's had two separate fleets: Maxinest® trays used for fresh produce and old 180° stack-nest for chilled meat, fish & ready meals. To drive supply chain efficiencies, having a single Maxinest® pool would save sortation costs, improve pool utilisation and increase vehicle fill. But the cost of manufacturing virgin crates was prohibitive.

### Our solution:

Schoeller Allibert recycled their old fleet of plastic trays into new EFSA approved food-safe Maxinest® trays.

### Main benefits:

A fully inter-stacking crate pool, improving ease of operation in stores and depots and supporting Sainsbury's ambition to adopt more sustainable practices.

For more information, please visit our website [www.schoellerallibert.com](http://www.schoellerallibert.com)

## Euro norm with Swings Bars

### Maxinest® 600 x 400

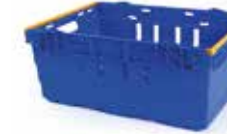

9632.002 - 44 L - Maxinest®  
Ext. (mm) 600 x 400 x 253  
Int. (mm) 547 x 349 x 226  
Weight (Kg) 2.01  
Stacked height 241  
Nesting ratio 75.00 %  
Version C / E / G



9788.002 - 67 L - Maxinest® Plus  
Ext. (mm) 600 x 400 x 360  
Int. (mm) 548 x 348 x 328  
Weight (Kg) 2.75  
Stacked height 340  
Nesting ratio 75.00 %  
Version C / E / G / I

### Euro 600 x 400



9791.002 - 45 L  
Ext. (mm) 600 x 400 x 253  
Int. (mm) 541 x 345 x 227  
Weight (Kg) 1.97  
Stacked height 241  
Nesting ratio 75.00 %  
Version C / E / G

Maxinest® compatible.



9959.002 - 54 L  
Ext. (mm) 600 x 400 x 303  
Int. (mm) 539 x 342 x 279  
Weight (Kg) 2.62  
Stacked height 288  
Nesting ratio 69.00 %  
Version C / E / G / I / K



9967.002 - 54 L  
Ext. (mm) 600 x 400 x 302  
Int. (mm) 570 x 370 x 270  
Weight (Kg) 2.08  
Stacked height 285  
Nesting ratio 66.00 %  
Version C / E / H



9761.002 - 68 L  
Ext. (mm) 600 x 400 x 368  
Int. (mm) 532 x 339 x 338  
Weight (Kg) 2.26  
Stacked height 363  
Nesting ratio 70.00 %  
Version B / E / H



9967.007 - 54 L  
Ext. (mm) 600 x 400 x 302  
Int. (mm) 541 x 346 x 270  
Weight (Kg) 2.35  
Stacked height 285  
Nesting ratio 66.00 %  
Version A / D / G

### Euro 800 x 600 - Maximeat®



9525.006 - 75 L  
Ext. (mm) 800 x 600 x 229  
Int. (mm) 718 x 524 x 190  
Weight (Kg) 3.92  
Stacked height 208  
Nesting ratio 76.00 %  
Version A / E / G / J



## Customer story

### Initial Situation:

Our Customer is a leading French retail company. Their first "Drive" opened in 2009. Metal shopping carts were used for order picking which caused damage to the content and were time-consuming.

### Our solution:

Deep Maxinest® crates with linkable dollies that can be linked 2 or 3 together to collate all crates per order. Operators wheel the dollies directly to the customer's car.

### Main benefits:

- The system speeds order picking.
- Saves 64% space compared to metal trolleys.
- Maxinest® crates protect content eliminating damage to fragile goods before customer collection.

For more information, please visit our website [www.schoellerallibert.com](http://www.schoellerallibert.com)

## Versions

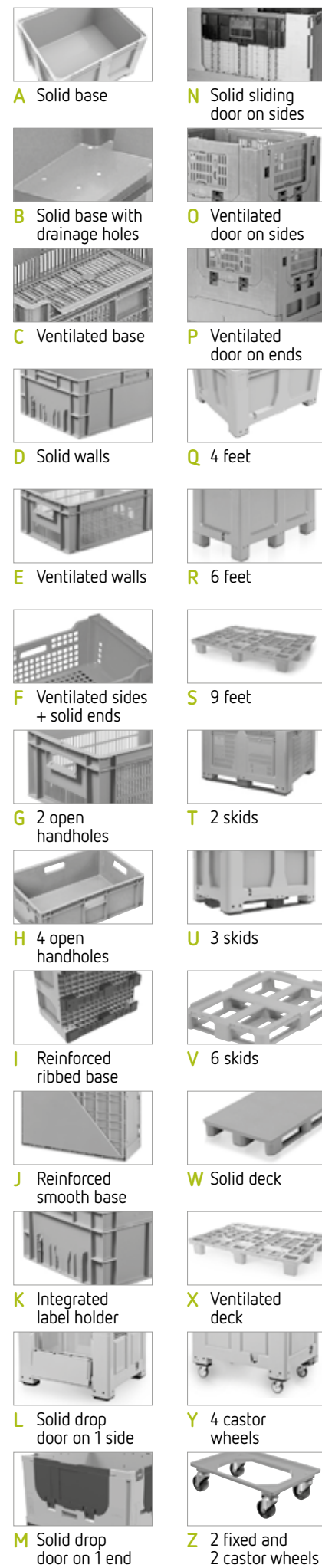

## Attached Lid Containers

### Kaiman® - 400 x 300

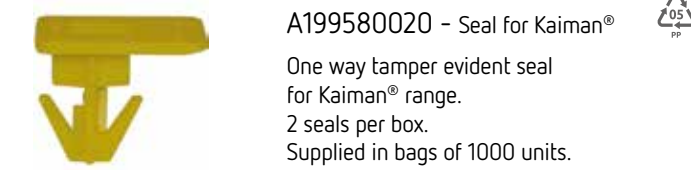
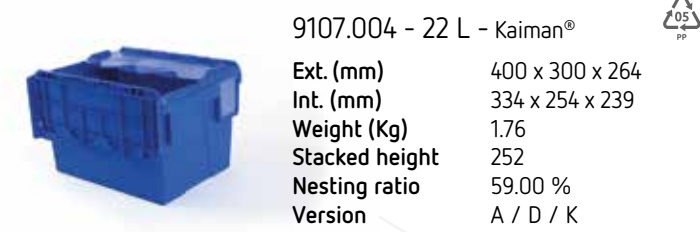
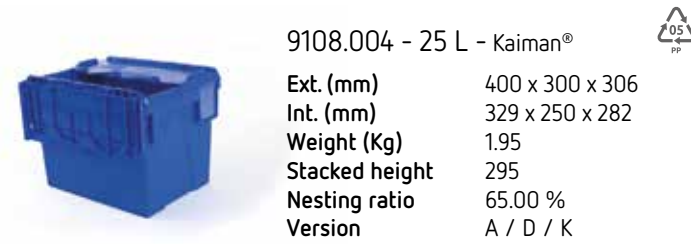

### Kaiman® - 600 x 400

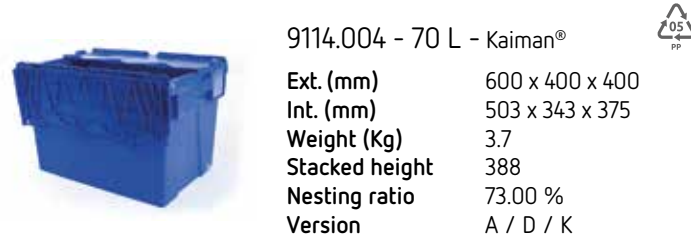
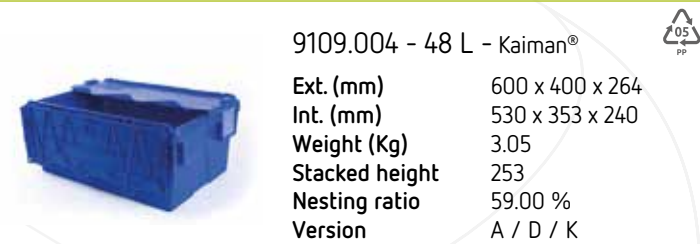

### Insulated Kaiman® for fresh and frozen food home delivery

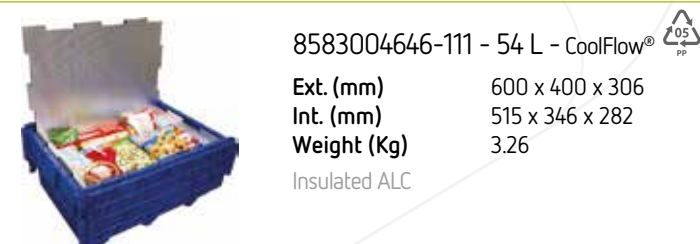

### Non Euro Kaiman®



## Attached Lid Containers

### Integra® - 400 x 300



### Integra® - 600 x 400

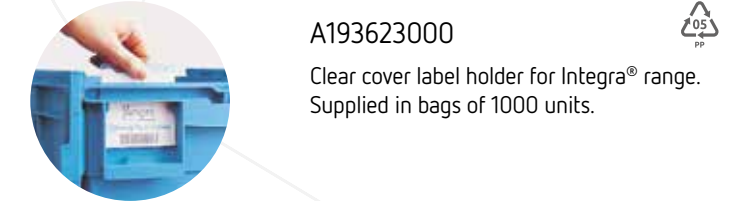
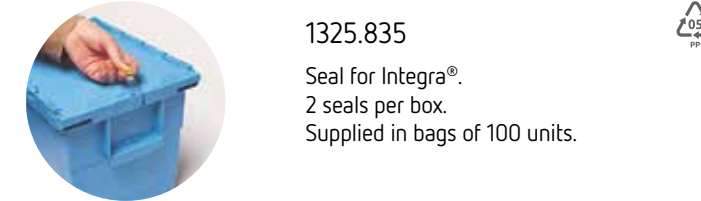

## Customer story

**Initial Situation:**  
The customer, a leading Scandinavian fashion retailer needed a container for delivery of clothing and linens from DC to retail stores.

**Our solution:**  
Goods arrive at the DC from suppliers in bulk packaging and are decanted into Integra® ALCs in suitable batch sizes to be delivered out to stores.

- Main benefits:**
- Saving on return transport and storage of empties thanks to Integra® 70% nesting ratio.
  - The containers also enable fast stock replenishment in store without disturbing customer activity.
  - The attached lid can be fitted with tamper-evident security seals to protect contents from opportunist theft and protects contents from rain, dust and dirt.
  - The container has good ergonomics, is compatible with conveyor belts and has multiple labelling possibilities.

→ For more information, please visit our website [www.schoellerallibert.com](http://www.schoellerallibert.com)

## Versions



A Solid base



N Solid sliding door on sides

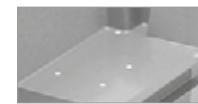

B Solid base with drainage holes



O Ventilated door on sides



C Ventilated base



P Ventilated door on ends



D Solid walls



Q 4 feet



E Ventilated walls



R 6 feet



F Ventilated sides + solid ends



S 9 feet



G 2 open handholes



T 2 skids



H 4 open handholes



U 3 skids



I Reinforced ribbed base



V 6 skids



J Reinforced smooth base



W Solid deck

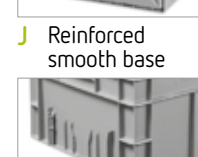

K Integrated label holder



X Ventilated deck



L Solid drop door on 1 side



Y 4 castor wheels



M Solid drop door on 1 end



Z 2 fixed and 2 castor wheels

## Stack Nest 180°

### Euro Stack/Nest - 600 x 400



9692.029 - 24 L  
Ext. (mm) 600 x 400 x 165  
Int. (mm) 530 x 330 x 139  
Weight (Kg) 1.97  
Stacked height 152  
Nesting ratio 58.00 %  
Version B / D



9567.000 - 50 L  
Ext. (mm) 600 x 400 x 300  
Int. (mm) 460 x 340 x 270  
Weight (Kg) 2.4  
Stacked height 285  
Nesting ratio 72.00 %  
Version A / D / G



9568.001 - 32 L  
Ext. (mm) 600 x 400 x 200  
Int. (mm) 457 x 338 x 177  
Weight (Kg) 1.74  
Stacked height 180  
Nesting ratio 70.00 %  
Version A / D / G



4130.760 - 66 L - Tellus  
Ext. (mm) 600 x 400 x 350  
Int. (mm) 515 x 368 x 332  
Weight (Kg) 2.47  
Stacked height 335  
Nesting ratio 66.00 %  
Version A / D



### Euro Stack/Nest 50 % - 600 x 400



9703.002 - 20 L  
Ext. (mm) 600 x 400 x 118  
Int. (mm) 556 x 357 x 100  
Weight (Kg) 1.37  
Stacked height 107  
Nesting ratio 34.00 %  
Version C / E / G



9692.006 - 46 L  
Ext. (mm) 600 x 400 x 244  
Int. (mm) 550 x 357 x 228  
Weight (Kg) 2.1  
Stacked height 233  
Nesting ratio 49.00 %  
Version C / E / G



9703.003 - 27 L  
Ext. (mm) 600 x 400 x 153  
Int. (mm) 556 x 357 x 135  
Weight (Kg) 1.5  
Stacked height 142  
Nesting ratio 48.00 %  
Version C / E / G



4105.750 - 48 L  
Ext. (mm) 600 x 400 x 280  
Int. (mm) 552 x 357 x 237  
Weight (Kg) 3.0  
Stacked height 255  
Nesting ratio 50.00 %  
Version A / D / H



### Non Euro Stack/Nest 180°



9690.000 - 35 L  
Ext. (mm) 500 x 400 x 270  
Int. (mm) 370 x 340 x 240  
Weight (Kg) 1.85  
Stacked height 245  
Nesting ratio 57.00 %  
Version A / D / G



9783.004 - 110 L  
Ext. (mm) 800 x 600 x 365  
Int. (mm) 640 x 487 x 345  
Weight (Kg) 4.57  
Stacked height 348.5  
Nesting ratio 73.00 %  
Version A / D



## Customer story

### Initial situation:

A major retail company in Germany wanted to replace its one-way packaging for the supply of fish to their stores.

### Our solution:

Stack nest bicolor box with external drainage (ref 9806029).

### Main benefits:

- No more compactors, for used Styrofoam boxes, no waste, optimized hygiene and safety, increased efficiency of store handling by operators.
- Improved payload in refrigerated trucks (+20% fish weight in trucks).

→ For more information, please visit our website [www.schoellerallibert.com](http://www.schoellerallibert.com)

## Stackable Containers | EasyStack®

Stackable containers are suitable for a variety of industries and offer efficient handling, storage and transport. Thanks to many different footprints, heights and variants in bases and walls they meet all kind of industry needs. Small, versatile and easy to handle, they are the perfect solution for automated handling systems.



Discover more in our stackable containers brochure

## 400 x 300

### EuroClick®



8300.000 - 10.2 L - EuroClick®  
Ext. (mm) 397 x 297 x 120  
Int. (mm) 367 x 267 x 107  
Weight (Kg) 0.77  
Stacked height 110  
Version A / D



8305.000 - 24.2 L - EuroClick®  
Ext. (mm) 397 x 297 x 270  
Int. (mm) 367 x 267 x 254.5  
Weight (Kg) 1.27  
Stacked height 257.5  
Version A / D



8301.000 - 12.6 L - EuroClick®  
Ext. (mm) 397 x 297 x 145  
Int. (mm) 367 x 267 x 132  
Weight (Kg) 0.85  
Stacked height 135  
Version A / D



8306.000 - 29 L - EuroClick®  
Ext. (mm) 397 x 297 x 320  
Int. (mm) 367 x 267 x 304.5  
Weight (Kg) 1.30  
Stacked height 307.5  
Version A / D



8302.000 - 15.4 L - EuroClick®  
Ext. (mm) 397 x 297 x 175  
Int. (mm) 367 x 267 x 162  
Weight (Kg) 0.97  
Stacked height 165  
Version A / D



8315.000 - Click Holder®  
Ext. (mm) 216 x 91 x 14.5  
Weight (Kg) 0.035



8303.000 - 19.7 L - EuroClick®  
Ext. (mm) 397 x 297 x 220  
Int. (mm) 367 x 267 x 207  
Weight (Kg) 1.1  
Stacked height 210  
Version A / D



8313.000 - Click Booster®  
Ext. (mm) 397 x 297 x 23.5  
Weight (Kg) 0.13



8304.000 - 20.9 L - EuroClick®  
Ext. (mm) 397 x 297 x 235  
Int. (mm) 367 x 267 x 219.5  
Weight (Kg) 1.12  
Stacked height 222.5  
Version A / D

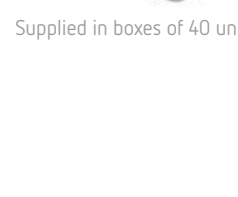





















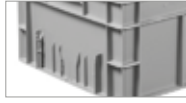





8705.820  
Ext. (mm) 400 x 300 x 26  
Weight (Kg) 0.34  
Version W



Supplied in boxes of 40 units.







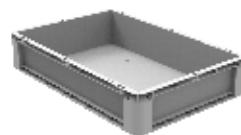

# Versions

-  **A** Solid base
-  **B** Solid base with drainage holes
-  **C** Ventilated base
-  **D** Solid walls
-  **E** Ventilated walls
-  **F** Ventilated sides + solid ends
-  **G** 2 open handholes
-  **H** 4 open handholes
-  **I** Reinforced ribbed base
-  **J** Reinforced smooth base
-  **K** Integrated label holder
-  **L** Solid drop door on 1 side
-  **M** Solid drop door on 1 end
-  **N** Solid sliding door on sides
-  **O** Ventilated door on sides
-  **P** Ventilated door on ends
-  **Q** 4 feet
-  **R** 6 feet
-  **S** 9 feet
-  **T** 2 skids
-  **U** 3 skids
-  **V** 6 skids
-  **W** Solid deck
-  **X** Ventilated deck
-  **Y** 4 castor wheels
-  **Z** 2 fixed and 2 castor wheels

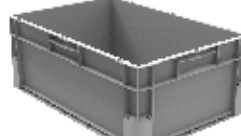
## 600 x 400

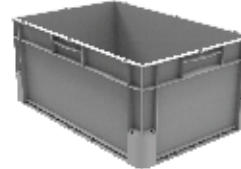
### EuroClick®

	8307.000 - 21.6 L - EuroClick® Ext. (mm) 597 x 397 x 120 Int. (mm) 567 x 367 x 106.5 Weight (Kg) 1.4 Stacked height 110 Version A / D
	8308.000 - 32.8 L - EuroClick® Ext. (mm) 597 x 397 x 175 Int. (mm) 567 x 367 x 161.5 Weight (Kg) 1.71 Stacked height 165 Version A / D
	8309.000 - 41.4 L - EuroClick® Ext. (mm) 597 x 397 x 220 Int. (mm) 567 x 367 x 204 Weight (Kg) 1.84 Stacked height 209.5 Version A / D
	8310.000 - 44.5 L - EuroClick® Ext. (mm) 597 x 397 x 235 Int. (mm) 567 x 367 x 219 Weight (Kg) 1.9 Stacked height 224.5 Version A / D

	8311.000 - 51.6 L - EuroClick® Ext. (mm) 597 x 397 x 270 Int. (mm) 567 x 367 x 254 Weight (Kg) 2.31 Stacked height 257.5 Version A / D
	8312.000 - 61.7 L - EuroClick® Ext. (mm) 597 x 397 x 320 Int. (mm) 567 x 367 x 304 Weight (Kg) 2.51 Stacked height 307.5 Version A / D
	8315.000 - Click Holder® Ext. (mm) 216 x 91 x 14.5 Weight (Kg) 0.035
	8314.000 - Click Booster® Ext. (mm) 597 x 397 x 23.5 Weight (Kg) 0.18
	8714.820 Ext. (mm) 600 x 400 x 26 Weight (Kg) 0.92 Version W



Supplied in boxes of 20 units.

### Miniload Container

	8477.027 - 56 L - Miniload Container Ext. (mm) 598 x 398 x 320 Int. (mm) 559 x 359 x 283 Weight (Kg) 3.35 Stacked height 307.5 Version D / J
---	---

8 holes on each walls for drainage.

	8465.001 - Long slotted divider Ext. (mm) 581 x 272 x 6 Weight (Kg) 0.403
---	---

	8466.004 - Short solid divider Ext. (mm) 381 x 272 x 6 Weight (Kg) 0.26
	8467.001 - Short slotted divider Ext. (mm) 381 x 272 x 6 Weight (Kg) 0.26
	Click Booster® Upon request only Please contact us



## Foldable Small Containers | MaxiFold®



Our versatile Foldable Small Containers (FSCs) are used in a wide range of industries and applications, from food retail supply chain to automotive parts distribution. Standard footprints and saving up to 85% space when folded, FSC's are the most profitable and environment friendly reusable logistics packaging solution.



Discover more in our foldable small containers brochure

### Prelog®

	3213.750 - 21 L - Prelog® Ext. (mm) 600 x 400 x 115 Int. (mm) 566 x 366 x 91 Weight (Kg) 1.87 Stacked height 107 Folded height 42 Version C / E / H / K
	3219.750 - 28 L - Prelog® Ext. (mm) 600 x 400 x 146 Int. (mm) 566 x 366 x 122 Weight (Kg) 1.72 Stacked height 138 Folded height 42 Version C / E / H / K
	3218.750 - 30 L - Prelog® Ext. (mm) 600 x 400 x 165 Int. (mm) 566 x 366 x 141 Weight (Kg) 1.8 Stacked height 157 Folded height 42 Version C / E / H / K

	3212.750 - 36 L - Prelog® Ext. (mm) 600 x 400 x 190 Int. (mm) 566 x 366 x 166 Weight (Kg) 1.9 Stacked height 182 Folded height 42 Version C / E / H / K
	3211.750 - 47 L - Prelog® Ext. (mm) 600 x 400 x 235 Int. (mm) 566 x 366 x 221 Weight (Kg) 2.1 Stacked height 227 Folded height 42 Version C / E / H / K

















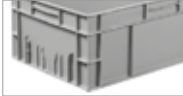









### Prelog® CMB

	1810.100 - 21 L - Prelog® CMB Ext. (mm) 400 x 300 x 240 Int. (mm) 364 x 264 x 216 Weight (Kg) 1.66 Stacked height 230 Folded height 52 Version A / D / G / K
	1811.100 - 68 L - Prelog® CMB Ext. (mm) 600 x 400 x 343 Int. (mm) 560 x 366 x 325 Weight (Kg) 3.5 Stacked height 333 Folded height 58 Version A / D / G / K

	1813.000 - 80 L - Prelog® CMB Ext. (mm) 600 x 400 x 400 Int. (mm) 570 x 370 x 380 Weight (Kg) 4.3 Stacked height 392 Folded height 67 Version A / D / G / K
	9672.004 - 178 L Ext. (mm) 800 x 600 x 465 Int. (mm) 760 x 560 x 420 Weight (Kg) 7.4 Stacked height 453 Folded height 108 Version A / D / K

Lid included. Available seal 1810.830 : Supplied in bags of 2000 units

## Versions

-  **A** Solid base
-  **N** Solid sliding door on sides
-  **B** Solid base with drainage holes
-  **O** Ventilated door on sides
-  **C** Ventilated base
-  **P** Ventilated door on ends
-  **D** Solid walls
-  **Q** 4 feet
-  **E** Ventilated walls
-  **R** 6 feet
-  **F** Ventilated sides + solid ends
-  **S** 9 feet
-  **G** 2 open handholes
-  **T** 2 skids
-  **H** 4 open handholes
-  **U** 3 skids
-  **I** Reinforced ribbed base
-  **V** 6 skids
-  **J** Reinforced smooth base
-  **W** Solid deck
-  **K** Integrated label holder
-  **X** Ventilated deck
-  **L** Solid drop door on 1 side
-  **Y** 4 castor wheels
-  **M** Solid drop door on 1 end
-  **Z** 2 fixed and 2 castor wheels

## Dollies | RollFlow®

Our dollies facilitate safe and easy moves of crate stacks. Standard or specific footprints, their decks' design allow most plastic containers and cardboard boxes to be held stable. Wheels are available in different materials to meet end uses requirements. Linkable models are perfect for retail and order preparation applications.



Discover more in our dollies brochure

### 600 x 400

 **8400.600** ABS  
**Ext. (mm)** 598 x 400 x 182  
**Weight (Kg)** 3.8  
**Wheels type** 4 swivel  
**Version** X / Z

Nylon wheels.

 **9193.025** ABS  
**Ext. (mm)** 604 x 402 x 162  
**Weight (Kg)** 3.5  
**Wheels type** 4 swivel  
**Version** X / Y

Nylon wheels.

 **8400.503** ABS  
**Ext. (mm)** 600 x 400 x 182  
**Weight (Kg)** 3.6  
**Wheels type** 4 swivel  
**Version** X / Y

Nylon wheels.

 **9193.002** ABS  
**Ext. (mm)** 604 x 402 x 162  
**Weight (Kg)** 4.0  
**Wheels type** 4 swivel  
**Version** X / Y

Rubber wheels.

 **9193.000** ABS  
**Ext. (mm)** 604 x 402 x 162  
**Weight (Kg)** 4.0  
**Wheels type** 4 swivel  
**Version** X / Y

Nylon wheels.

 **9191.001 - Linkable Dolly** PP  
**Ext. (mm)** 604 x 454 x 195  
**Weight (Kg)** 4.2  
**Wheels type** 4 swivel  
**Version** X / Y

Nylon wheels.

### 800 x 600

 **9192.004 - Universal Dolly** PP  
**Ext. (mm)** 800 x 600 x 171  
**Weight (Kg)** 9.7  
**Wheels type** 2 fix 2 swivel  
**Version** W / Z

Rubber wheels. With brake 500 Kg load.

 **9198.000** PP  
**Ext. (mm)** 1300 x 350 x 300  
**Weight (Kg)** 2.0

Shaft for dolly ref.9192.004



## Customer story

### Initial Situation:

Pallets and roll cages were used for deliveries from distribution centre to retail stores. They were not space efficient and hindered stock replenishment, especially during busy periods.

### Our solution:

800 x 600 mm Universal Dollies for delivering fresh produce in Maxinest® trays which are picked and loaded onto dollies at the DC before being dispatched to store.

### Main benefits:

Universal Dollies are more cost efficient than conventional roll cages and more hygienic than wood pallets. They have speeded supply chain operations as trays are more easily lifted from dolly to shelf and, unlike pallets, can be wheeled without the need for pump trucks.

→ For more information, please visit our website [www.schoellerallibert.com](http://www.schoellerallibert.com)

[www.schoellerallibert.com](http://www.schoellerallibert.com) | [webshop.schoellerallibert.com](http://webshop.schoellerallibert.com)

## Mission Statement

Schoeller Allibert has been inventing, developing, designing and manufacturing Returnable Transit Packaging (RTP) for more than 50 years. We have a rich heritage, having been formed from the key players: Schoeller, Wavin, Perstorp, Arca, Linpac, Allibert, Paxton, Stucki amongst others. Today we are the European market leader with operations worldwide.

**Markets:** We focus on seven key segments being agriculture, automotive, food and food processing, beverage, retail, industrial manufacturing and pooling through our customers.

**Products:** We offer a comprehensive range of standard and tailor made RTP.

**Services:** As well as standard models we offer a bespoke innovative design and engineering service.

**Benefits of our products:** High quality, durable and sustainable enabling our customers to enhance supply chain efficiency and profitability, lower transport cost, reduce waste and enhance green branding.

**Operations:** Lean manufacturing and supply chain operations focused on right first-time quality products delivered on-time and in-full.

**Support functions:** Efficient and effective, focussed on the customer and adding value.

**People:** Inclusive environment where all employees have all the tools they need to perform to their best, are recognized and valued, are encouraged to learn and grow and to contribute to continuously improving our performance.

**Financial:** We aim to enhance shareholder value and provide the required returns in the long-term.

EFSA approval granted to Schoeller Allibert for innovative recycling process



Grocery retailers can now have their old returnable transit packaging (RTP) recycled into new high-quality food grade containers, thanks to Schoeller Allibert's European Food Safety Authority (EFSA) accredited recycling process.

The accredited process, which covers the recycling of food-grade HDPE and PP crates into new containers for food contact, has been developed in order to help food processing companies and retailers to meet increasing stringent sustainability targets. No pollution, no waste. We take care of all the necessary steps, creating a 100% sustainable packaging cycle.

## Do you want to know more ?

Please visit our website [www.schoellerallibert.com](http://www.schoellerallibert.com)



[www.schoellerallibert.com](http://www.schoellerallibert.com)



① **Head Office Netherlands**  
**Schoeller Allibert Services B.V.**  
Taurusavenue 35  
NL-2132 LS Hoofddorp  
00 31 88 0047300

② **Austria**  
**Schoeller Allibert GmbH**  
Rudolf Diesel-Strasse 26  
AT-2700 Wr. Neustadt  
00 43 2622 206 56

③ **Belgium**  
**Schoeller Allibert bvba**  
Industrieweg 143,  
BE – 3583 Beringen  
00 32 11 39 38 38

④ **Czech Republic**  
**Schoeller Allibert Czech Republic s.r.o.**  
NA Rovince 879  
CZ-720 00 Ostrava  
00 420 596 790 010

⑤ **Finland**  
**Schoeller Allibert Oy**  
Askonkatu 9 F  
FI-15100 Lahti  
00 358 848 211

⑥ **France**  
**Schoeller Allibert France**  
176 avenue Charles de Gaulle  
FR-92200 Neuilly-sur-Seine  
00 33 1 41 20 09 90

⑦ **Germany**  
**Schoeller Allibert GmbH**  
Vossstrasse 20  
DE-10117 Berlin  
00 49 30 36471 100

⑧ **Hungary**  
**Schoeller Allibert Hungary Kft**  
Szabadság út 117. 2. emelet  
HU-2040 Budaörs  
00 36 23 332 010

⑨ **Italy**  
**Schoeller Allibert S.p.A.**  
Via Enzo Ferrari, 1 -Frazione  
Zucche  
IT-10040 Volvera (TO)  
00 39 011 39 75 759

⑩ **Latvia**  
**Schoeller Allibert SIA**  
Ritausmas street 2  
LV-1058 Riga  
00 371 673 822 80

⑪ **Netherlands**  
**Schoeller Allibert B.V.**  
Bruchterweg 88, NL-7772 BJ Hardenberg  
Postbus 176, NL-7701 AD Hardenberg  
00 31 523 727 026

⑫ **Poland**  
**Schoeller Allibert Sp. z o.o.**  
ul. Fryderyka Wilhelma Redena 5  
PL-41-808 Zabrze  
00 48 32 283 13 10

⑬ **Romania**  
**Schoeller Allibert SRL**  
Str Turnu Magurele nr. 270 D  
RO-041713 Bucharest  
00 40 21 460 20 88

⑭ **Russia**  
**Schoeller Allibert ZAO**  
Business center LETO, office 508  
Sverdlovskaya nab., 44  
RU-195027 St. Petersburg  
00 7 812 326 65 20

⑮ **Slovakia**  
**Schoeller Allibert s.r.o.**  
Kominárska 2,4  
SK-831 04 Bratislava  
00 421 2 555 65940

⑯ **Spain**  
**Schoeller Allibert, SAU**  
Av. Camí Reial, 8  
Pl. Riera de Caldes  
ES-08184 Palau-Solità i Plegamans, Barcelona  
00 34 93 864 0080

⑰ **Sweden**  
**Schoeller Allibert Sweden AB**  
Hässelholmsvägen 10, P.O. Box 82  
SE-28422 Perstorp  
00 46 435 777 000

⑱ **Switzerland**  
**Schoeller Allibert Swiss Sàrl**  
Route de la Condemine 11  
CH- 1680 Romont  
00 41 266 519 210

⑲ **United Kingdom & Ireland**  
**Schoeller Allibert Limited**  
Road One Industrial Estate  
GB-CW7 3RA Winsford  
00 44 1606 561900

⑳ **International**  
**Schoeller Allibert International GmbH**  
Zugspitzstrasse 15  
DE-82049 Pullach  
00 49 89 638 66 0

#### Other continents

**Chile**  
**Logipak Schoeller Allibert SPA**  
Hermanos carrera into 79  
Colina, Santiago, Chile  
0056 (2) 24815970

**China**  
**Schoeller Allibert China**  
Room 115, Unit A3, No.700 Wanrong Road,Zhabei District  
CN-200072 Shanghai  
00 86 21 31 33 50 80

**Mexico**  
**Schoeller Allibert International México, S.A. de C.V.**  
Avenida Cafetales 1702 D-205  
Col. Hacienda de Coyoacán  
Delegación Coyoacán  
C.P. 04970  
México D.F.  
0049 89 638 66 0

**UAE**  
**Schoeller Allibert International Middle East LLC**  
Office 117 Abu Dhabi Airport Business Park  
PO Box 2131  
AE- Abu Dhabi, UAE  
00971 2 419 2771

**USA**  
**Schoeller Allibert**  
4320 S. Cotton Lane Suite 200  
Goodyear, AZ 85338  
00 1 623 889 7970



**Schoeller Allibert**

[www.schoellerallibert.com](http://www.schoellerallibert.com) | [webshop.schoellerallibert.com](http://webshop.schoellerallibert.com)