

Chair Topper[®]

A roof top box that lifts and stows a folding wheelchair

Thank you for choosing a

Chair Topper® from BraunAbility!

The following manual is an important part of the product, providing you with information on how to achieve maximum performance and safe operation. Keep the manual in a safe place so that you can refer to it when necessary.

If you have any questions about your adaptation, please contact your installation engineer. If you want to know more about us and our range of car adaptation solutions visit www.braunability.eu.

Once again, thank you for placing your confidence in our products!



Safety

6

Operation

8

Emergency operation

10

Maintenance

16

Troubleshooting

19

Technical specification

21

Introduction for users

22

EN

Index

“Product certificate” at the end of the manual.

Safety



Maximum wheelchair load is 20 kg, see safety decal below.



Load and unload on level surface only. Engage vehicle parking brake before operating.



Provide adequate clearance outside the vehicle to accommodate the fully extended Chair Topper before operation.



Keep operator and bystanders clear of area in which the Chair Topper operates.



Keep the hand control in a safe place when not in use to avoid accidental use while driving the vehicle.



If the rubber seal becomes wet and exposed to sub-zero temperatures the compartment might freeze shut. To prevent this, apply a thin coating of silicone grease on the rubber seal.

Safety decals located on Chair Topper /



My Chair Topper

Combined height of vehicle and Chair Topper at the time of installation, _____ cm.

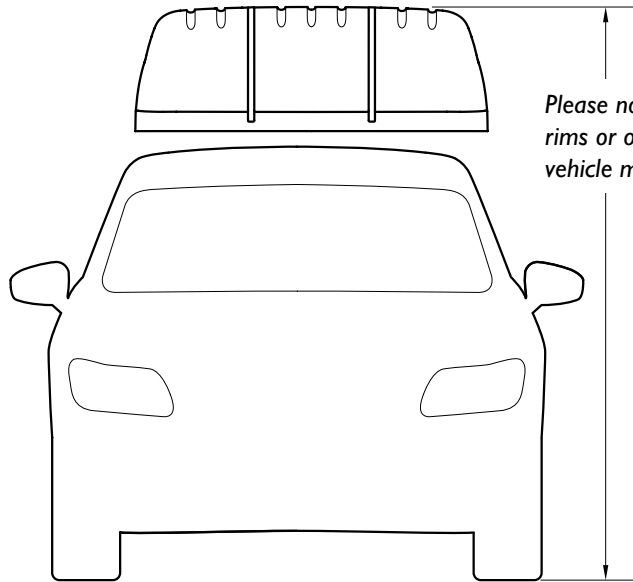

Please note that changing the wheels, rims or other modifications to the vehicle might affect the total height.

Operation

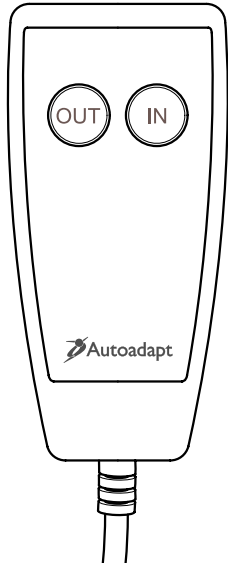

LOAD /

1. Open the vehicle door fully.
2. Transfer from wheelchair to the vehicle. Leave the wheelchair remaining completely unfolded and facing towards the front of the vehicle. Lock the wheelchair brakes for safety.
3. Press the OUT button and carefully lower the hook. Release the button when the hook has reached the desired height.
4. Position wheelchair at the predetermined position and insert the hook securely under the wheelchair seat.
5. Press the IN button and carefully hoist the wheelchair. Release the button when the Chair Topper is fully closed.

UNLOAD /

1. Open the vehicle door fully.
2. Press the OUT button and carefully lower the wheelchair. Release the button when the wheelchair has reached the ground level.
3. Remove the hook from the wheelchair.
4. Press the IN button and carefully hoist the hook. Release the button when the Chair Topper is fully closed.

BEFORE TRANSPORT /

1. Place the hand held control in its cradle to avoid accidental activation of the Chair Topper.



Be cautious that no swinging motion occurs. To interrupt the operation at any time, release the button. If the Chair Topper fails to open using the hand control, refer to chapter "Emergency operation".



To avoid accidental activation of the Chair Topper the hand held control must be placed in its cradle at all times.

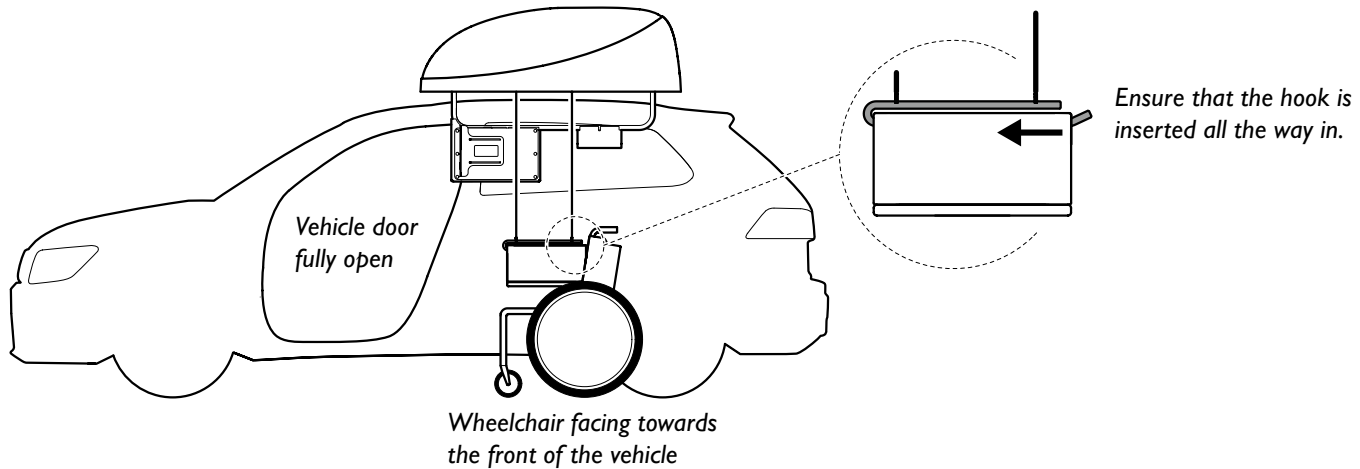

Emergency operation

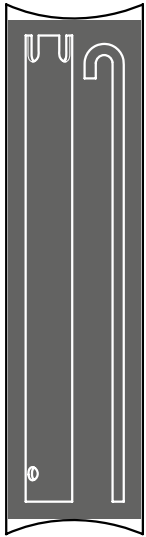

Use the emergency kit, supplied with the Chair Topper, to facilitate the emergency operation.

OUT



1 Remove the plug from the cover.

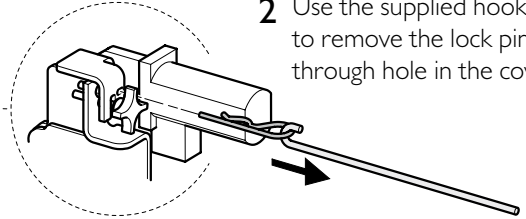
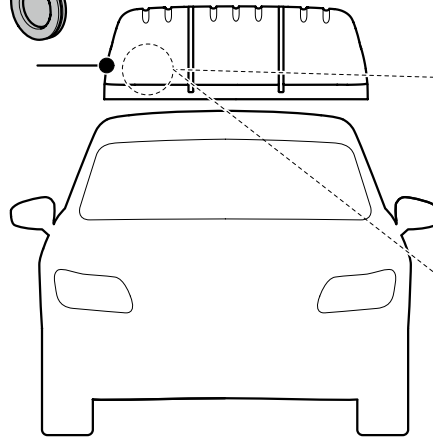

2 Use the supplied hook to remove the lock pin through hole in the cover.

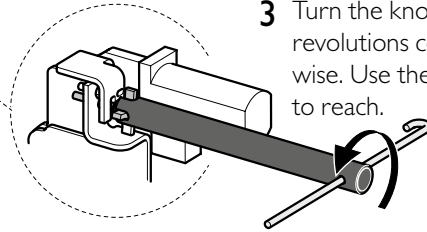

3 Turn the knob 15 full revolutions counter clock wise. Use the slotted tube to reach.



Always contact your installation technician after an emergency operation to fix the fault before using Chair Topper again.

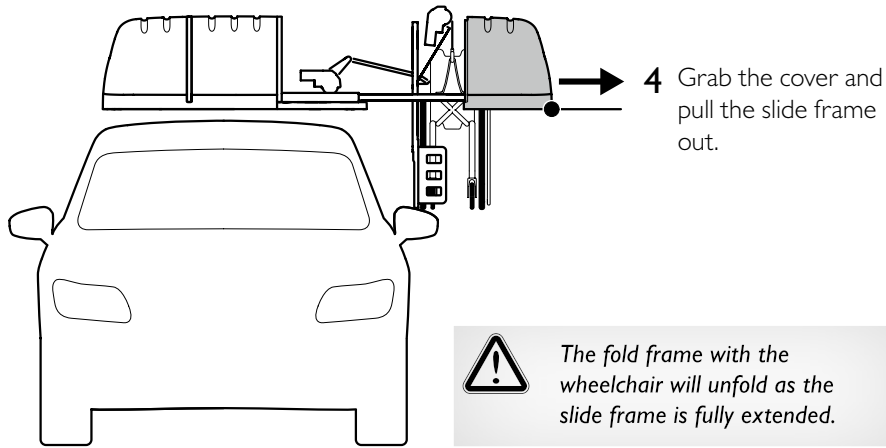

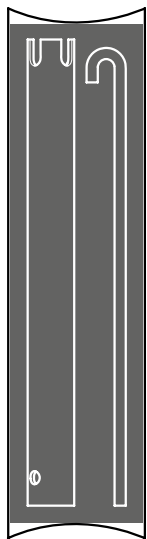

Use the emergency kit, supplied with the Chair Topper, to facilitate the emergency operation.

DOWN

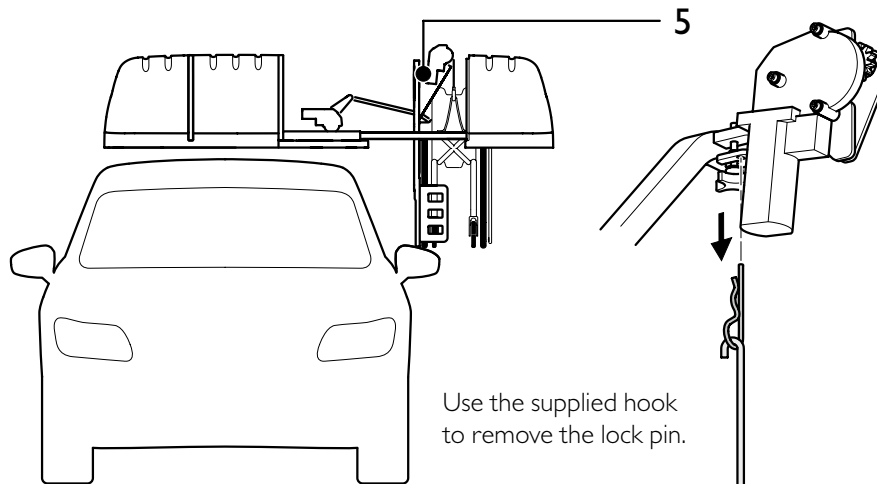

Use the supplied hook to remove the lock pin.



Always contact your installation technician after an emergency operation to fix the fault before using Chair Topper again.

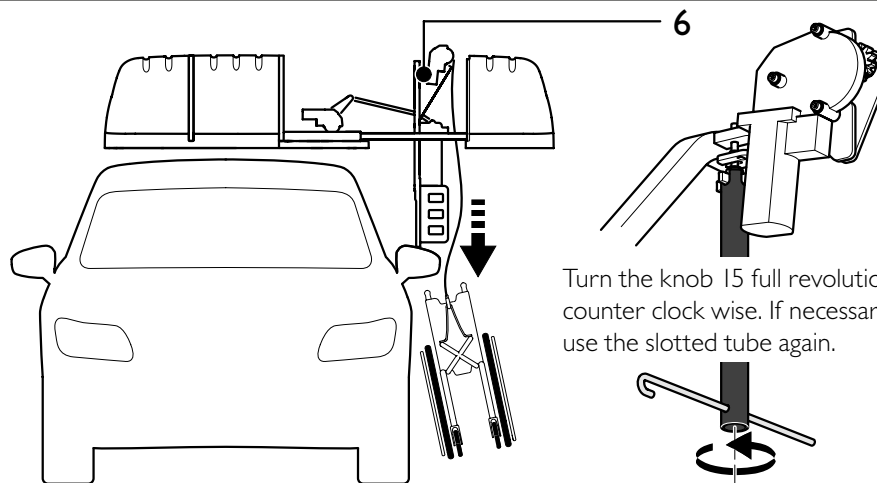

Turn the knob 15 full revolutions counter clock wise. If necessary use the slotted tube again.

! DANGER

RISK OF BODILY INJURY AND MATERIAL DAMAGE

During this procedure the wheelchair will suddenly drop and free fall from the Chair Topper. Unless held by a person of adequate strength, it may cause injury to anyone in its path as well as cause damage to the vehicle.

UP and IN

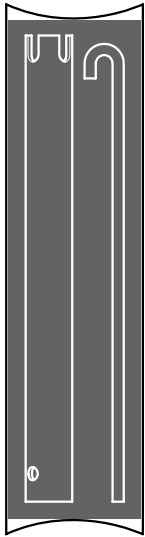

Use the emergency kit, supplied with the Chair Topper, to facilitate the emergency operation.

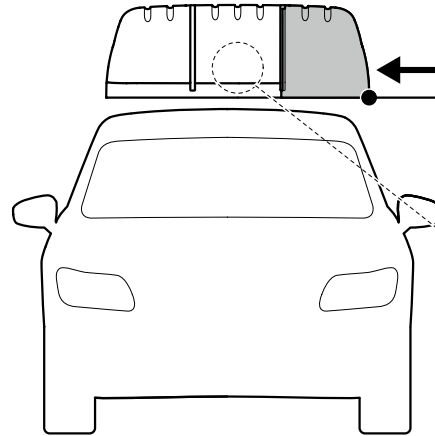

Push in the slide frame until the fold frame is in a horizontal position. Place the seat hook and chains on top of the fold frame. Continue to push in the slide frame until it is fully closed.

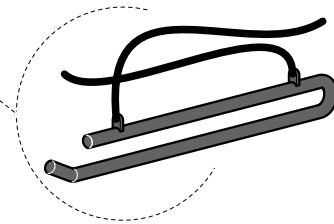

Always contact your installation technician after an emergency operation to fix the fault before using Chair Topper again.

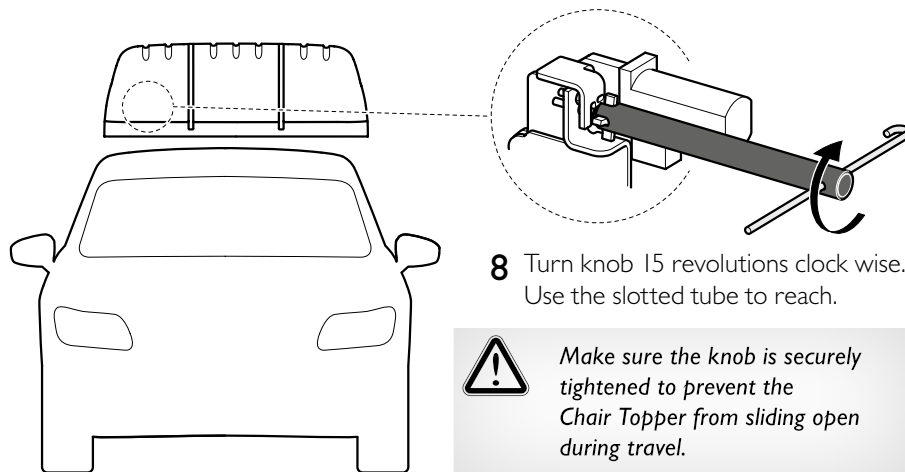

Maintenance



Any maintenance, modifications or repairs to the Chair Topper may only be performed by a qualified installation technician.



Press the OUT button to deploy Chair Topper fully and then disconnect the red 12-gauge power wire from the battery prior to any servicing or repairs.

Perform maintenance at the scheduled intervals according to the number of cycles or elapsed time whichever comes first. Always contact your dealer for disassembly.

Wash and/or wax the ABS plastic in the same manner which you care for your vehicle.

4 weeks or 100 cycles	Inspect all bearings for wear. Lubricate with light oil.
	Fold linkage pivot points. Lubricate with light oil.
	Remove and clean any debris or obstructions.
	Inspect bearing mounting for proper securement. Correct and replace if needed.
	Inspect mounting hardware (frame and topper securement). Make sure there are no loose or missing parts. Replace, tighten or resecure as needed.
3 months or 300 cycles	Repeat all checks listed in the 4 weeks or 100 cycles. Repeat maintenance procedures.
	Inspect sprockets for securement, slippage, alignment or any damage. Replace, realign or resecure as needed.
	Inspect chain channels (plastic for damage, securement or obstructions. Clean, correct or replace.

3 months or 300 cycles	Inspect chain bolts and all chain connecting points. Inspect master links and chain blocks for positive securement and/or possible damage. Replace, resecure or correct as needed.
	Inspect chains for lubrication, damage, misalignment, binding or twisting. Lubricate with light oil. Clean before lubricating - realign or correct any other conditions as needed.
	Inspect chain boxes (up/down chain enclosure) for obstructions or damage. Clean or correct.
	Inspect the side bearing channel on both sides for damage, securement or obstructions. Clean, resecure or correct as needed.
	Inspect all mounting hardware (securing framework, hearings, linkage, motors, etc.) for loos, damaged or missing parts. Replace, tighten, adjust or realign as needed.
	Inspect main wiring harness for possible damage, securement or poor electrical connections. Correct, resecure or repair as needed.
	Inspect control harness for possible damage; securement, or poor electrical connections. Correct, resecure or repair as needed.
	Inspect power cable for damage or poor connections. Correct or replace as needed.
	Inspect ground wires damage, securement or poor connections. Correct, resecure or repair as needed.
	Inspect the harness/wire socks attachment points on wind screen of vehicle. Replace worn or missing cable tie/cable tie attachment feet.
	Inspect fold springs to see if detached or worn. Correct or replace.
	Inspect fold linkage for excessive wear, damage, lubrication and securement. Lubricate with light oil, resecure or realign as needed.
Inspect pop rivets/washers (securing ABS plastic shell) to see if worn or missing. Replace or resecure as needed.	

<p>1 year or 1250 cycles</p>	<p>Repeat all checks listed in the two previous sections. Repeat maintenance procedures.</p>
	<p>Inspect fuse holder and electrical connections. Correct as needed.</p>
	<p>Inspect the channel on both sides for damage, securement or obstructions. Clean, resecure or correct as needed. Lubricate black plastic bearing on three sides with a thin layer of <i>AGS door-ease stick lubricant</i>.</p>
	<p>Inspect the two micro switches for possible damage, securement or poor electrical connections. Replace, resecure or correct wiring connections as needed.</p>
	<p>Inspect relays/relay blocks for possible damage, securement or poor electrical connections. Replace, resecure or correct wiring connections as needed.</p>
	<p>Inspect seals and gaskets to see if damaged, worn or missing. Correct as needed.</p>
	<p>Inspect decals. Replace if worn, missing or illegible.</p>
	<p>Internal moisture (from use during rain or snow). Leave open on dry day to dry interior.</p>

Troubleshooting

Hand held control does not work.....

- Check that the wiring to the hand held control is connected and undamaged.
- Check that the fuse is intact and that the vehicle battery is charged.
- Follow the instructions for “**Emergency operation**”.

Unusual noises heard during operation.....

- Do not use the Chair Topper. Contact your installation technician for an overhaul.

Please contact your installation engineer if you require further assistance or need to ask questions about warranty. We recommend keeping the following information to hand at all times /

Contact details for the installation engineer /

Model /

Serial number /

Year of manufacture /

Date of purchase /

Notes /

Technical specification

Dimensions

A, length	143 cm
B, width	131 cm
C, height.....	46+10* cm
D, extension	91 cm
E, chain length (200 cm with ext. kit)...	109 cm
F, max folded height.....	93 cm
G, max folded apex height.....	83 cm
H, max folded width.....	35 cm

Product data

Lift capacity.....	20 kg
Unit weight.....	55 kg
Fuse auto reset.....	15A
Motors	12VDC
Load cycle time	30 sec

All weights and dimensions are for reference only.

*During operation the product extends an additional 10 cm in height.

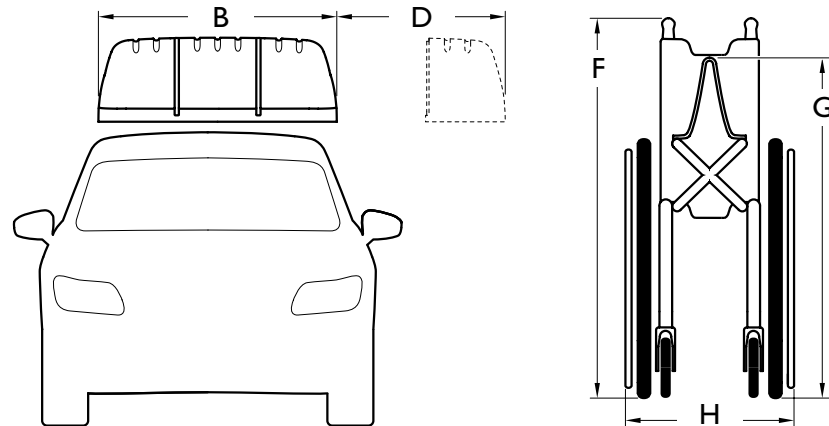
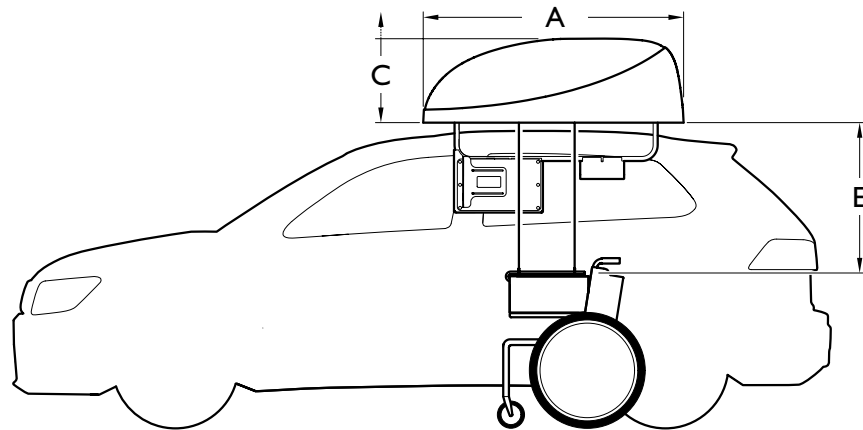

Introduction for users

BraunAbility Europe AB would like you, as a user, to feel secure and comfortable with your new product. For that reason, it is your installer's duty to go through the following with you /

Safety
Operation
Emergency-mode operation

If any questions about the product should come up later on, you are of course very welcome to contact your installation engineer again.

The above chapters have been gone through /

Date /

Name of dealer /

Signature, installation engineer

Signature, user

Product certificate

Manufacturer /

BraunAbility Europe AB
Åkerivägen 7
443 61 Stenkullen
Sweden

Phone: +46 302 254 00
E-mail: info@braunability.eu
www.braunability.eu

Declares that the product /

Chairtopper, model left/right

Conforms to following directives, standards and regulations /

2006/42/EEC
ECE R-10
ISO 11154

BraunAbility Europe AB, Stenkullen
2019-04-02



Jan M Jensen
Managing Director



Accredited by SWEDAC as testing laboratory in accordance with ISO/IEC 17025:2005
Quality system certified in accordance with ISO 9001:2015

Illustrations, descriptions and specifications in the user manual are based on current product information.
BraunAbility Europe AB reserves the right to make alterations without previous notice.
© 2019 BraunAbility Europe AB



BraunAbility Europe AB
Åkerivägen 7
443 61 Stenkullen
Sweden

Phone: +46 302 254 00
E-mail: info@braunability.eu
www.braunability.eu