

Hive EV Charging

EO Mini Pro 3 Installation Guide



Contents

Before you start	3
Charger installation	4
Software setup	9
Smart Charging	12
Randomised Delay	13
PEN fault detection	14
Connection options	14
Wi-Fi connectivity	15
GSM - Hive SIM	18
Customer registration	19
Wiring connections	22
Status light	22
Hive support centre	23



Before you start

IMPORTANT!

- Failure to register with the EO academy may invalidate the customer warranty. DO NOT continue with installation until you have registered.
- After installation you must provide the EIC (Electrical Installation Certificate) to the customer. This is a requirement of wiring regulations (BS 7671).
- Please ensure all necessary checks are done and that the application to connect is compliant with the Energy Network Associations guidelines.

1. Register with EO as an installer and complete the necessary induction modules. This will take approximately 20 minutes.

<https://eouk-eocharging.talentlms.com/>

2. Ensure you have access to a mobile device that can connect to Wi-Fi, and appropriately sized cable glands, based on cable sizing.
3. Find the Installer Details label within the rear housing (see below) and take a clear photo where you can read the text clearly. **You will need to refer to this later.**

NOTE: Technical support is available from Hive at <https://hivehome.com/guides/ev-charging> or call +44 (0)333 202 1054 (UK) or 01 611 0189 (RoI).

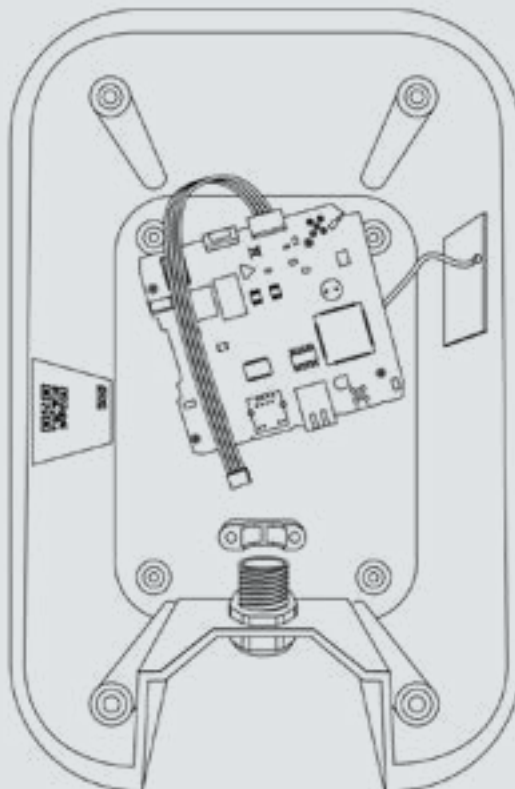

Charger installation

1. Remove all packaging.

In the box:

A) Fascia – this is the last component to fit

B) Centre section containing the charger socket and main electrical components

C) Rear housing containing the electronics, including the Wi-Fi and GSM modems, make sure you have a clear photo of the Installer Details label on the inside wall of the main housing (see image C)

Please note the diagrams below and throughout this guide are based on the untethered version – installation requirements remain the same for tethered chargers.

A



B



C

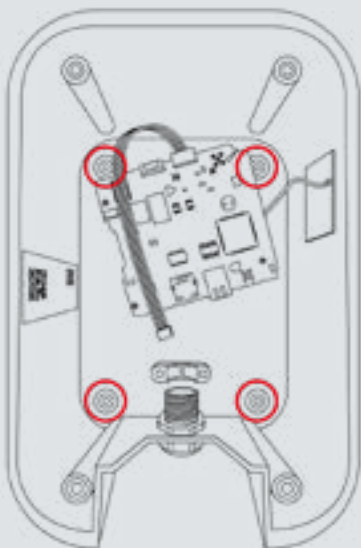
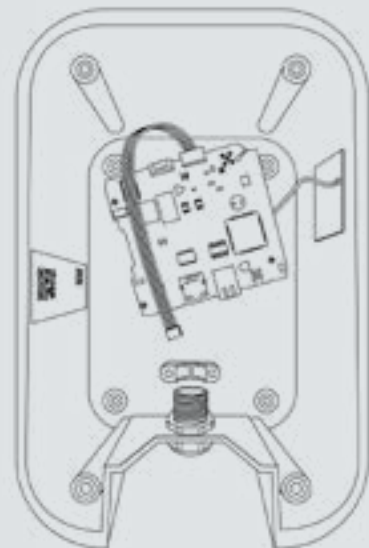

2. Place the base of the EO Mini Pro 3 in the installation location and make sure the surface is flat and level.
3. Level the EO Mini Pro 3 base and mark the position of the four holes.
4. Take the EO Mini Pro 3 base away and drill the four holes in the mounting surface.

5. If using Ethernet as a means of connecting to the client router, CT clamps need to be fed into the Mini Pro 3, then the second aperture can be drilled out and a suitable gland fitted. In all cases, a separate, suitably rated IP gland should be used for the Ethernet cable entry to the unit.

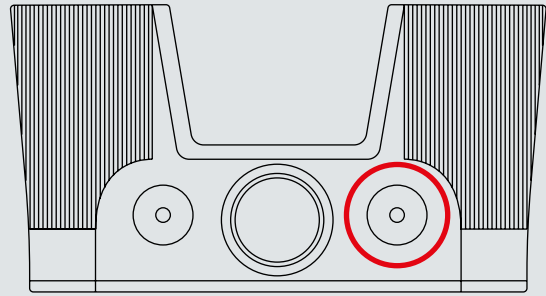

6. The rear charger housing allows for one rear cable entry using the position as shown on the image.



DO NOT drill into any other area of the housings as doing so will invalidate the product warranty and could damage the rear internal PCB.

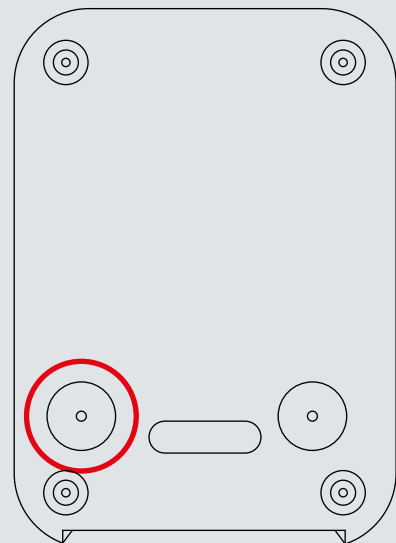

7. If using Ethernet, connect it to the RJ45 female connector located on the Mini Pro 3 circuit board.

Please ensure that any rear entry glanding has a suitable IP rating and that consideration is given to the depth and fit of the gland against flat surfaces.

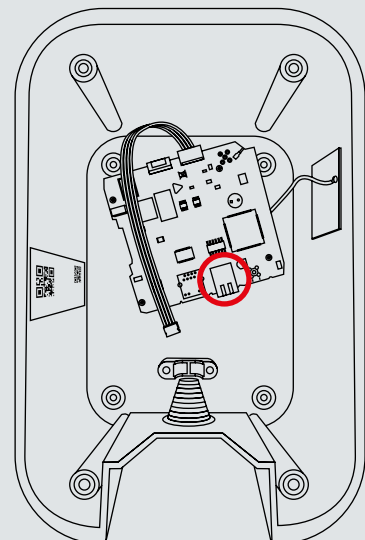

8. Attach the EO Mini Pro 3 base to the wall using the four screws provided. Make sure the charger is secure and flush against the wall. Use packing washers if necessary for a flush fit.
9. Strip and prepare the power cable and feed into the pre-made hole and stuffing gland, using an appropriately sized gland (25mm gland provided).

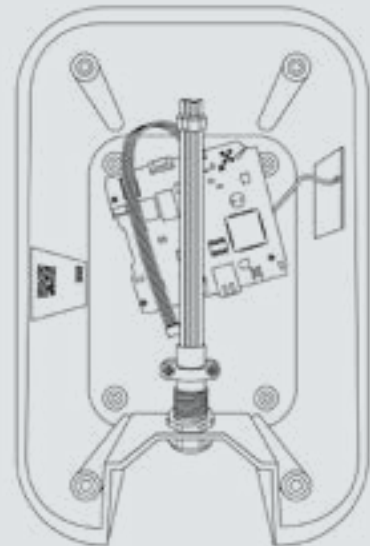

10. Connect the live, neutral, and earth wires to the charger connector block.

NOTE: There is no need to modify (tighten or loosen) either of the following connections in the charger as all of these fixings are tightened to the correct setting in the factory:

- Mains Power Terminal
- Castle nuts on the PCB

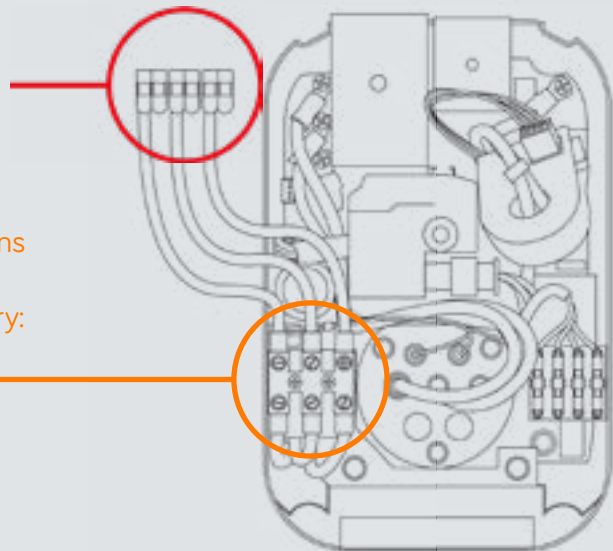

When connecting CT clamps for load management, there is a four-pin connector block in the lower right of the unit (see right). Ensure this is firmly seated before moving on and that the sheathed screen cable for the data cable is connected to earth.

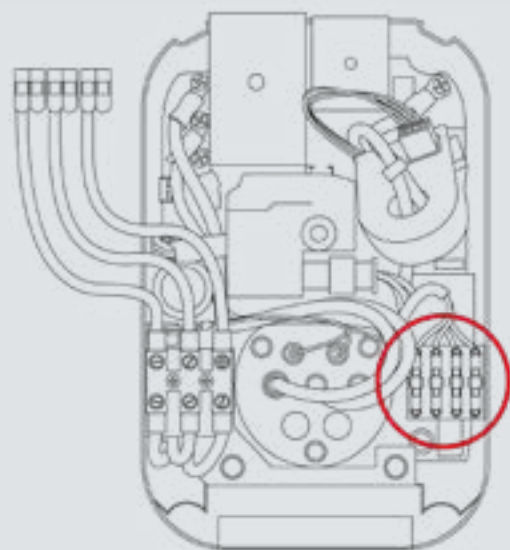

Wire designations for load management

Connector Number	CT Assignment	CT Wiring Colour	Function
1	CT1A	Red	ALM
2	CT1B	White	ALM

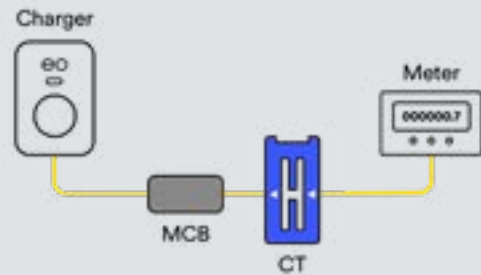

The CT clamps supplied have a red and white wire attached to them.

NOTE: The shielding from the signal cable shall be grounded.

The CT for load management should be connected to CT1. Connect the red wire to position 1 and the white wire to position 2.

Make sure to orientate the CT clamps correctly when connecting them to the supply cable.

The clamps have an arrow which should be orientated with the current flow, which is the flow from the supply.

11. Take a photo of the Installer Details label if you haven't already. You will need this information to configure the charger once the unit is assembled.
12. Before closing the charger case, check that the PCB tethering lead is plugged in and connects both front and rear PCB boards together, as shown on the next page.



NOTE: CT clamps are included with your Hive EO Mini Pro 3 and are recommended to be installed as per the above instructions. If you decide not to install CT clamps you will need to ensure that Load Management is **NOT** enabled (pages 9 & 10).



Make sure the PCB tethering lead is connected to the right-hand male connector of the rear case, as below:

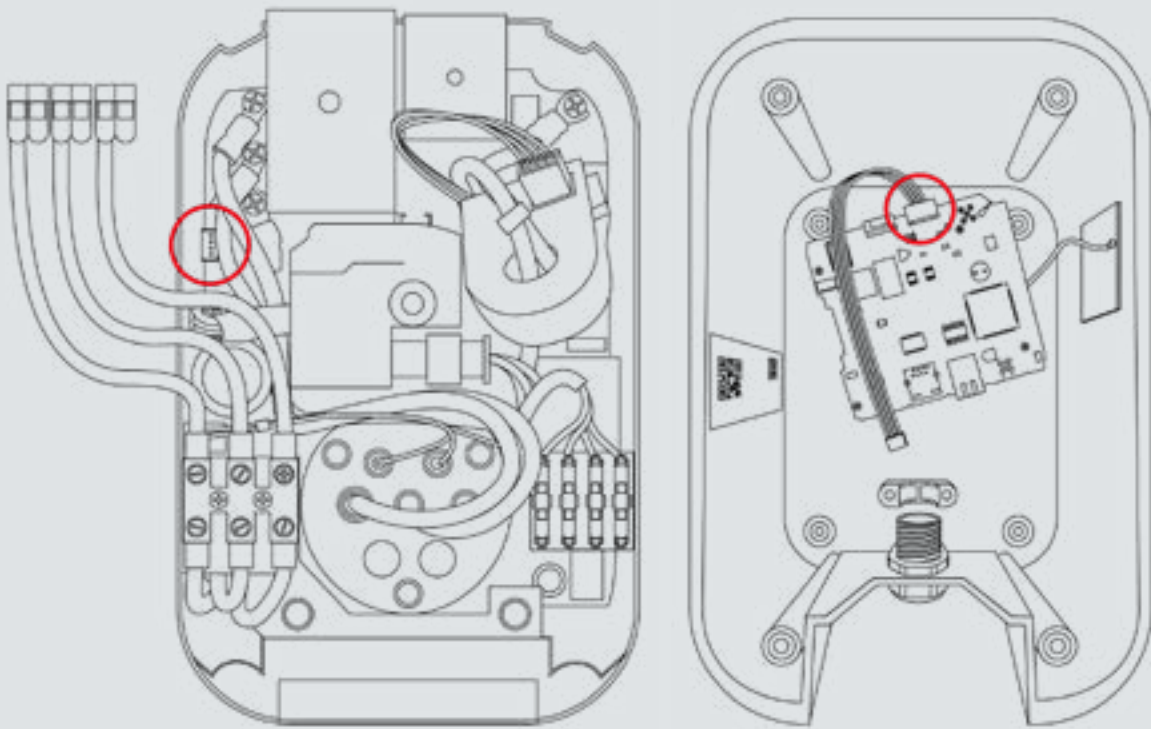

13. With all cables securely connected, close the Mini Pro 3 cases together, making sure no internal cabling is trapped, and secure the housings together with the four hex bolts and washers.
14. Do not attach the fascia to the EO Mini Pro 3 until all testing is done. Complete all testing before closing the unit.



Software setup

1. Power up the charger.
2. You will see a hotspot with the name eo-xxxxxxxxxxxxx – it may take a couple of minutes to appear. The hotspot expires after 10 minutes if no connection is made. You must power the charger down and back up again to reactivate the hotspot.
3. Use a laptop or mobile device to search for the Wi-Fi hotspot and join it, using the credentials on the Installer Details label – you should be able to see these in the photo you took earlier of the label.



NOTE: For Windows OS, you may be limited to entering eight characters into the password field. To enable more characters, click **Connect using a security key** instead.

4. Once connected to the hotspot, open your device's web browser.
5. In the address bar, type 10.10.10.1 – your browser may warn you with a security message. Accept it and proceed.
6. You should now see the charge point User Interface [UI] login page.



7. Enter the UI credentials from the Installer Details label.

8. Confirm charger settings.

Installer Settings

Charger Settings

Timezone
(UTC+0000) Dublin, Edinburgh, Lisbon, London [Save Timezone](#)

Charger Current Limit (A)
32

Installer Info

Installer Name (name) Installer Company (name) Installer Email (email)

EVSE #1/3

Tilt/Bump Detection

Enabled Bump Amplitude (1 - 100) TS Range (1 - 20) [Save Tilt + Calibrate](#)

- Enter your installer details.
Please note, failure to enter these details **WILL** invalidate the customer's warranty.
- Tap Save Tilt + Calibrate to confirm if you have changed any of these values.

Phase Settings

Number Phase Selection Phase Connection (ph)

External Metering

External CT Clamps Enabled

CT Clamps

Clamp #	Switch	Rating (A)	Type
Clamp #1	<input checked="" type="checkbox"/>	63	<input type="text" value="Site"/>
Clamp #2	<input type="checkbox"/>	63	<input type="text" value="Site"/>

[Save all configurations + calibrate](#)

[Save + Calibrate](#)

- Load management is enabled by default and requires a CT clamp to be fitted. If you do not fit a CT clamp, then Load Management needs to be disabled.
- If an external CT clamp has been fitted, enable the option, enter the CT rating and set the Type to Site.
- Make sure your CT clamp is connected at the outgoing live cable from your electric meter, then click Save + Calibrate.

CT Types

Source: An external source of energy.

Site: Boundary point into a property which will contain the charger usage within it.

Load: An external load to the charger that does not contain the charger usage.

NOTE: Site is the expected setting.

Load Management

Where a CT clamp is fitted you can set parameters for load management on the Load Balancing page.

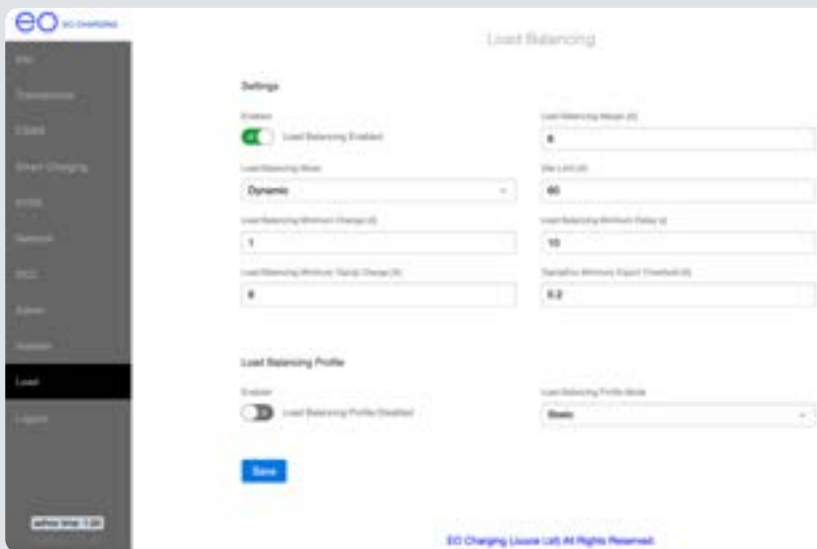

Load balancing is switched off by default so slide the toggle to allow inputs.

Main fuse size in property	60 Amp	80 Amp	100 Amp
Site value limit to input = main fuse size (SVL)	60A	80A	100A
Load balancing margin for 60 Amp (ALM60)	6A	20A	40A
Load balancing margin for 80 Amp (ALM80)	N/A	1A	20A
Load balancing margin for 100 Amp (ALM100)	N/A	N/A	1A
Connect and Notify* (CN)	1A	20A	40A
Apply to connect - (A2C) (looped supply, etc.) (Fuse upgrade)	1A	1A	1A

***NOTE:** The ENA will accept a Connect and Notify if

- Maximum Demand and charger < 60A
- Maximum Demand < 60A, connection = OK and the load management is set to 60 Amps

Note the above are regardless of the fuse rating of the property and it is the responsibility of the installer to adhere to the ENA guidelines.



Smart Charging

In accordance with UK regulations, all chargers are supplied with a Smart Charging profile enabled. Customers can log in to the charging station using their EV user account to view their transaction history and modify their default charging schedules and Randomised Delay settings.

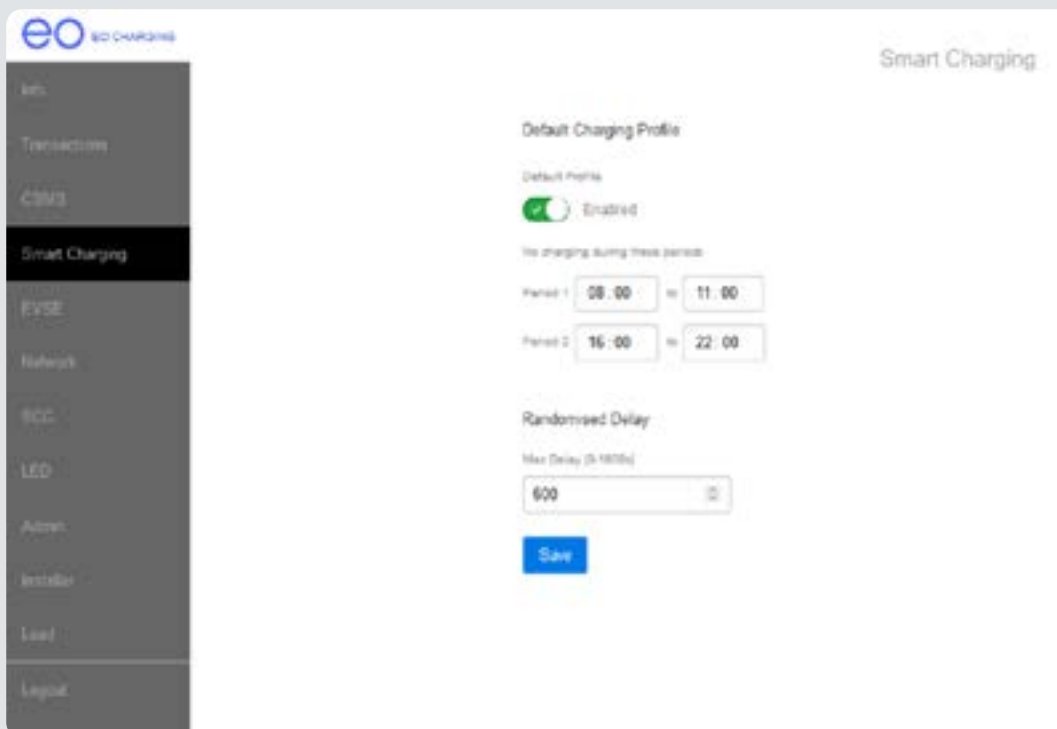

If the charger is going to be used with the Hive app:

Disable the toggle beneath Default Profile and set the Max Delay (beneath Randomised Delay) to 0. These will be overridden by the Hive app.

If the charger is going to be used as a non-smart charger, without the Hive app:

Set the Default Profile to suit the customer's requirements. Otherwise, they will only be able to charge outside of the periods set by the factory.

Set Max Delay to 600s and check all settings with the customer. Otherwise, the charger may not work as they expect.

NOTE: Any Smart Charging settings you configure for non-smart operation may impact testing or demonstration of the device to the user. After you have confirmed these settings in line with the end user's requirements, you may need to temporarily disable the Smart Charging profile (using the toggle under Default Profile) to carry out any test or demonstration. To re-enable it after your testing/demonstration is complete please follow the initial hotspot connection process and navigate back to the Default Profile section.



Randomised Delay

There is a risk of overloading the grid if lots of people start or stop charging their EV at the same time. To avoid this, all EV chargers now have a Randomised Delay feature. This means that there will be a random delay of up to 10 minutes when customers start or stop charging, which will help the grid stay balanced.

This setting is a legal requirement so it can't be switched off, but it doesn't apply to customers who have their own energy generation (such as wind or solar) and are using their own excess energy. EV chargers that provide Demand Side Response are also exempt.

The default setting is 600 seconds. This means that when the customer plugs their EV into the charger, it will start charging anywhere between immediately and 10 minutes later.

If it is set to zero, the charger will always try to start charging as soon as an EV is plugged in.

IMPORTANT: NEVER give a customer your installer access credentials as it could cause damage and be a health and safety risk. Customers can amend their settings with their own login details, which are provided on their own access label. The functions they can access are limited for safety reasons. They can find more details in their user guide.



PEN fault detection

Hive's EO Mini Pro 3 models HIVE-EV-01 and HIVE-EV-02 have built-in Protective Multiple Earth (PEN) fault detection and no configuration is needed.

Connection options

The Hive EO Mini Pro 3 has been developed with three methods of connection to the Hive platform. During the installation you should consult with the customer and choose the most effective method of communication that suits their home and the installation location.

It's important to choose an option which provides the most robust connection method as the Hive EO Mini Pro 3's advanced features and control via the Hive app depend on a stable and consistent connection.

The connection options available are:

- Ethernet (LAN)
- Wi-Fi
- GSM (SIM)

Network (LAN) connectivity

When using a hard-wired connection to a LAN, make sure a working connection to the client's network is available prior to installation or the charging stations will fail to connect to the Hive platform. When connecting to the Hive platform please ensure that ports 80 and 443 are open.

By default the ethernet port is enabled and set up for dynamic DHCP. If a static IP address is required then the DHCP switch should be set to Static and then IP address details should be entered.

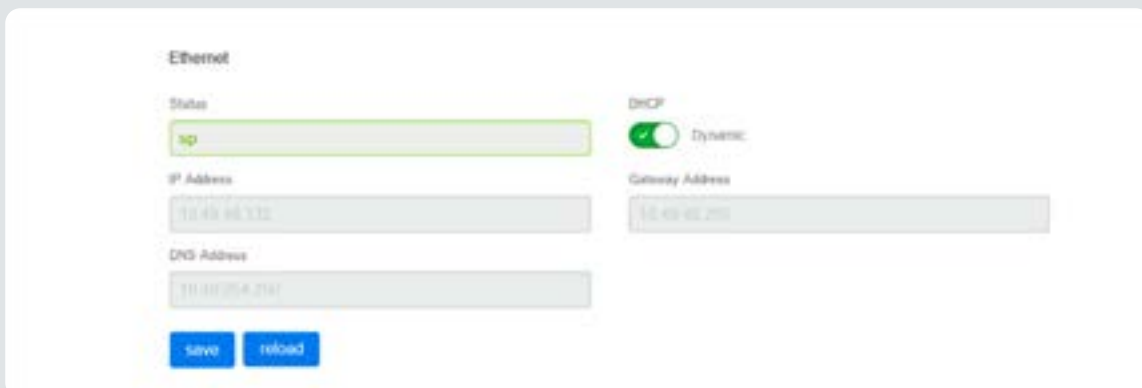

The screenshot shows the 'Ethernet' configuration page. It includes a 'Status' dropdown menu set to 'ip', a 'DHCP' toggle switch set to 'Dynamic', and input fields for 'IP Address' (192.168.1.100), 'Gateway Address' (192.168.1.1), and 'DNS Address' (192.168.1.1). There are 'save' and 'reload' buttons at the bottom.

Wi-Fi connectivity

If the Hive EO Mini Pro 3 is to use Wi-Fi for its internet connection to the Hive platform, before fitting the device in place, it is recommended that the strength and integrity of the Wi-Fi signal is checked. If a weak Wi-Fi signal is present, then there is a chance that the installation of the charging station may fail. To check that the Wi-Fi signal is strong enough please complete the following steps:

1. Ensure that a 2.4GHz Wi-Fi network is available.
2. Utilise a suitable Wi-Fi analyser mobile device app to verify signal stability, strength, and interference levels.
3. Using a mobile device connect to the premises' Wi-Fi router (if the customer grants permission).
4. Measure the data rate and signal noise. The data rate should be greater than 5mbs and using an appropriate mobile app, measure the signal noise [RSSI] value which should be less than 67dBm.

Tip! When configuring Wi-Fi, you can view the signal strength of the network from the charger UI when selecting your network. Signal strength is indicated by a % value after the given network's name.

NOTE: If the Wi-Fi is not suitable, a couple of options exist:

1. Install a 2.4GHz Wi-Fi booster.
2. Use the hard-wired ethernet option.



Configuring a Wi-Fi connection

If you are connecting the Hive EO Mini Pro 3 to a customer's Wi-Fi then please:

1. Enable Wi-Fi

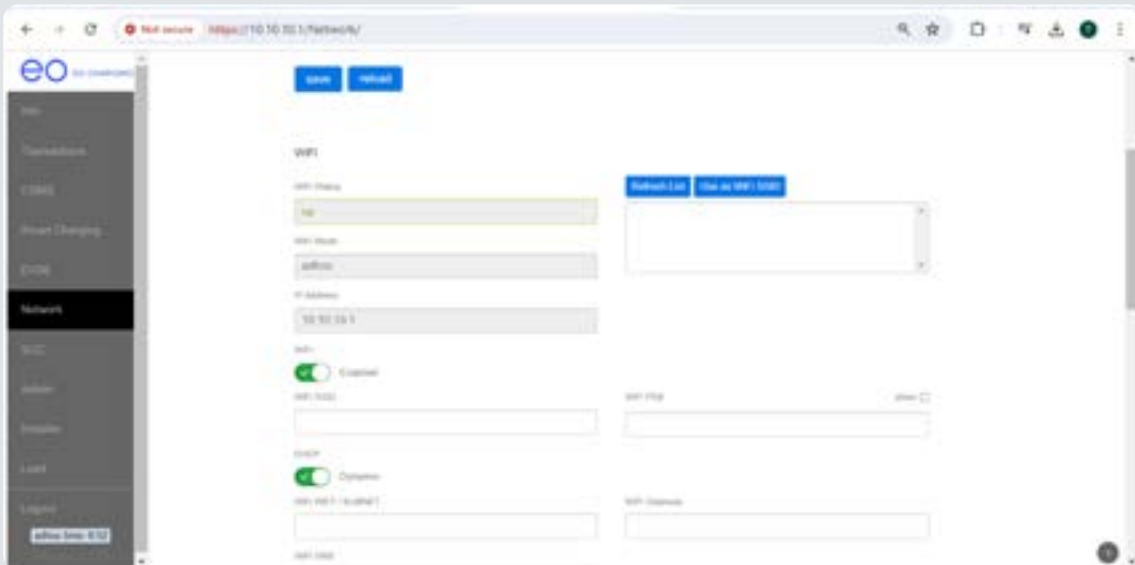

2. In order to view the list of available Wi-Fi networks, click on the “Refresh List” button.

3. This will show the list of available networks and their associated signal strengths.

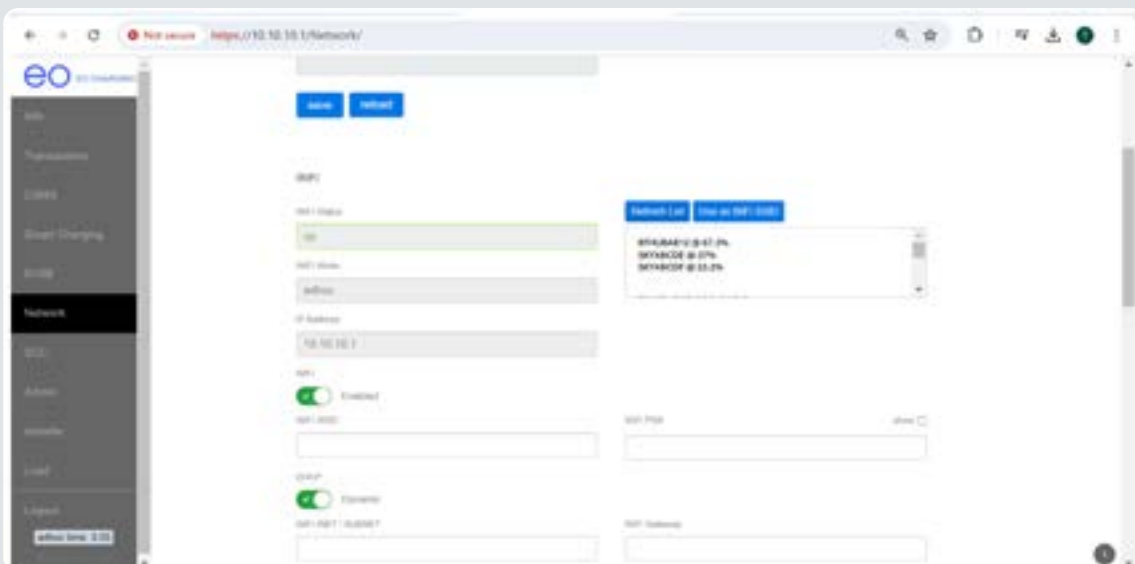

4. Select the chosen network and then click on the “use as Wi-Fi SSID” button.

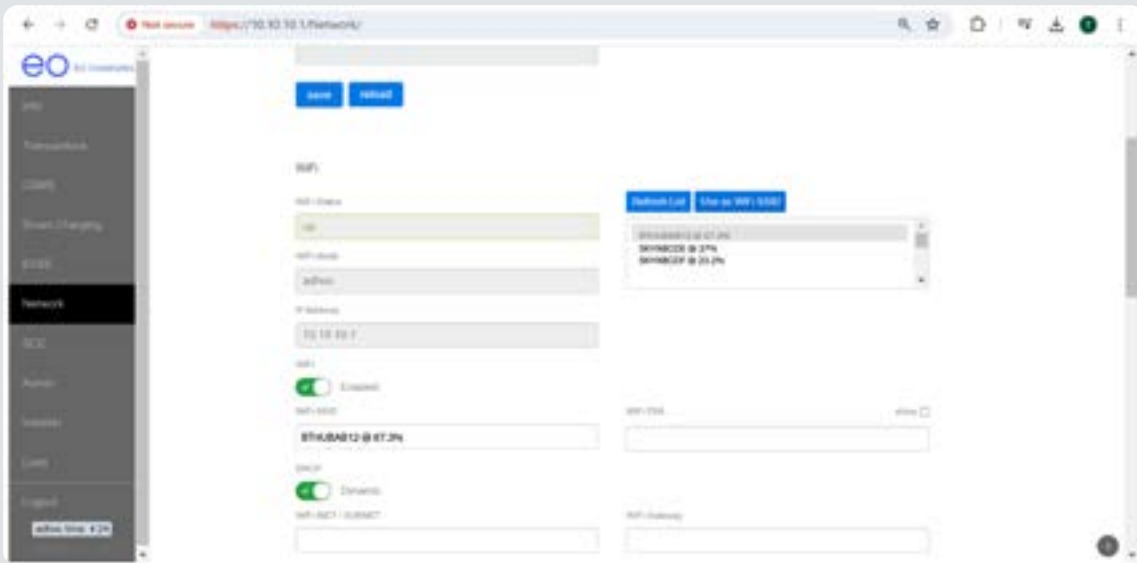

5. This will then populate the “Wi-Fi SSID” text field allowing the installer to enter the Wi-Fi password into the Wi-Fi PSK field.

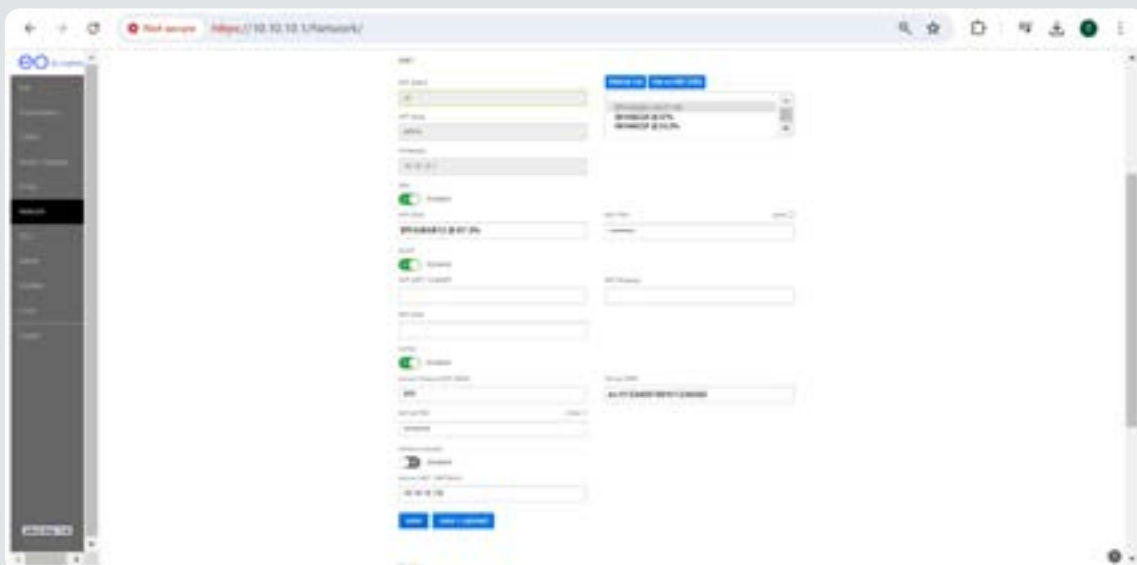

6. Once all Wi-Fi details have been input, press “Save” to ensure they are stored on the charger.

GSM – Hive SIM

For units that are GSM-enabled with a Hive SIM:

1. Select the Network page from the left-hand menu.
2. At the bottom of the page, you will find a Modem section showing SIM status details. Do not change these settings.
3. Modem Status messages:
 - **SIM Status:** This shows the charger can see the SIM and communicate with it.
 - **IP:** Displays the IP address assigned by the network provider.
 - **PING Test:** Displays a successful communication ping to the back office.
 - **RSSI:** Signal strength.

The screenshot displays the 'Modem' section of a web interface. It contains several input fields and status indicators:

- ICCID:** 01234567890123456789
- IMSI:** 240075810009903
- APN:** BQ545602E79302
- CCPS:** Automatic, Vodafone UK, User-specified GSM access technology
- RSSI (dBm):** -60
- SIM Status:** SIM OK
- IP:** 172.17.62.125
- PING IP:** 0.0.0.0
- PING Test:** Successful

Below these fields are two blue buttons: 'reconnect modem (interface + service)' and 'refresh modem info'. At the bottom, there are fields for 'APN' (stream.co.uk), 'Username' (default), and 'Password' (---), with a 'Show' checkbox and a 'Save' button.

4. Connection via GSM will not occur unless the Wi-Fi hotspot connection has timed out or closed so disconnect from the hotspot and reboot the charger.

Physical EO Mini Pro 3 installation is now complete. The customer can now log in to the Hive app to complete setup of the charger. If the customer has not received a charger PIN from Hive then please follow the customer registration steps which follow.

NOTE: If you are unable to connect the charger via GSM, please contact Hive Support on +44 (0)333 202 1054.

Customer registration

The customer needs to be registered with Hive to receive the PIN that is required to add their EO Mini Pro 3 charger to the Hive app. You can complete this by:

- Going to hivehome.com/ev-charging-retail or scanning the QR code on the Installer Details label
- Entering their details on the registration form
- Adding their Charger PIN, which they'll receive by email from Hive

NOTE: If you are installing this device in a new-build property or somewhere else where you do not have the customer's details, the registration process allows you to input information so Hive can onboard the customer later.

After completing the installation and configuration of the charger, it might update to the latest firmware. This might take a few minutes.



Important installation information

Topic	Note
Characteristics of power supply input	Permanently connected to 230V
Characteristics of power supply output	Supplies 230V AC to the vehicle
Normal environmental conditions	Can be installed indoors or outdoors
Access requirements	Can be installed with no access restrictions
Mounting method	Stationary equipment intended for surface or post mounting
Protection against electric shock	Class I equipment
Charging mode	Mode 3 charging equipment
Ventilation during the supply of energy	Does not support ventilation during charging
Ingress protection	IP54
Mechanical strength	IK08
Operating temperature	-25 °C to +50 °C
Height of installation	The charging equipment should be mounted with the bottom face of the enclosure at least 0.9m above ground level. For tethered units, the holster height should be between 0.5m and 1.5m above ground level.
Usage of adaptors/cord extension sets	Adaptors and conversion adaptors sets are not permitted to be used with the equipment. Cord extension sets are not permitted to be used.
Maximum altitude	2000m
Pollution degree	Pollution Degree 2
Torque setting for main input cables	1.2Nm
Skill level	Operation by ordinary - Installation by skilled authorised electrician
Nature of short-circuit protective device	Upstream RCD Type A required - Internal: 6mA DC Leakage, PEN, LoE, LoN
Torque setting for main chassis screws	6Nm
Measures for protection against electric shock	Where the EO Mini Pro 3 includes internal 6mA DC leakage protection (DCL option), then a 30mA Type A RCD must be fitted at the supply. Otherwise, a Type B RCD or equivalent should be used. EO recommends a 40A supply for a 32A charging station. Overcurrent protection (e.g. MCB) should be installed upstream of the charging station.
Short-circuit protection of the charging cable	40A Type B or Type C MCB with a maximum I _{2t} of + Socket version should be ≤ 75000 A ² s + Tethered version should be ≤ 80000 A ² s.
Fuse rating	3.15A, 240V time delayed cartridge fuse
Overvoltage category	Category 3
Rated Insulation Voltage	230V

Rated impulse withstand voltage Uimp	4000V
Rated peak withstand current (Ipk)	≤ 80kA2s
Rated short time withstand current (Icw)	N/A
Rated conditional short-circuit current of an ASSEMBLY (Icc)	5000A2s
Electromagnetic compatibility (EMC) classification	EN 61851-21-2:2021 Residential and Non Residential EN 55032:2015 + A1:2020 Class B ENI EN 301 489-1 V2.2.3:2019 EN 300 328 V2.2.2:2019 EMC Directive 2014/30/EU and UK Electromagnetic compatibility Regulations 2016
Dimensions and weight	230mm x 151mm x 125mm, <2kg (socketed), <5kg (tethered)
Storage	Dry storage location in ambient temperatures between 0 °C and 30 °C
Maximum charging rate	32 Amps

IMPORTANT: The installer must select the RCD and earthing configuration by following the current local regulations and best practices. The installer must follow national usage guidelines to ensure the unit is installed in accordance with any local restrictions. For the UK refer to the current IET code of practice and a Type A RCD and Type B MCB are recommended.

Wiring connections

Physical connections

Wiring system	Power connections on EO Mini Pro 3		
	PE	N	L1
TN (230V)	PE	N	L1

PE = Protective Earth

N = Neutral

L1 = Line/Phase 1

L2 = Line/Phase 2

Status light

The EO Mini Pro 3 has a status LED on the front face to show its status.

When powering up

LED colour	State	Notes
Not illuminated	Power off	No power is available
LED solid white	Initialising	Initialising
LED pulses blue	Ready	The unit has started up successfully and is ready to charge*

*Once the LED pulses blue, it may take up to a further 10 minutes for the charger to connect to the Hive platform, which enables control and smart functionality within the Hive app.



During normal operation

LED state	State	Charger state
LED solid white	Initialising	Initialising
LED slow pulsing blue	Ready	Charger is ready to charge but cable is not connected to charger or car
LED fast pulsing blue	Preparing	Charger is connected to car but charging session has not started
LED solid green	Charging	A charging session has started successfully
LED pulsing green	Charging suspended	A charging session is suspended either due to the charging schedule or the car settings
LED solid red	Fault condition	A fault has occurred
LED pulsing blue and green	Firmware update	The Hive EO Mini Pro 3 is updating to the latest firmware. Once complete the charger will reboot
LED pulsing red and green	Device tamper notification	This indicates that the internal tamper boundary of the device has been triggered

Hive support centre

Get help at hivehome.com/guides/ev-charging or call **+44 (0)333 202 1054**.

This document contains information that is subject to change without notice.

The latest version of this guide can be downloaded at:

hivehome.com/guides/ev-charging

Disclaimer: No part of this publication may be reproduced or transmitted in any form or by any means, electronic or mechanical, including, but not limited to, copying, recording, retrieving data, or computer networks without the written permission of Centrica Hive.

