



**A SEAMLESS BLEND OF  
FUNCTIONALITY AND  
AESTHETICS**

**TITANE NEXT**  
High Traffic Commercial Door



By  Hydro

↗ **Windows** ↗ **Doors** ↗ **Facades** ↗ **Sliders**



## TITANE NEXT

➤ HIGH TRAFFIC COMMERCIAL DOOR

### THE ULTIMATE SHOP FRONT AND COMMERCIAL BUILDING DOOR SOLUTION

Easy to manufacture and assemble, TITANE NEXT is a state-of-the-art shop front and commercial building aluminium door solution, designed to meet the unique requirements of the building industry.

Engineered with cutting-edge technology, this remarkable system offers exceptional thermal performance and larger dimensions, providing a seamless blend of functionality, aesthetics, and energy efficiency.

#### **STRONGLY COMMITTED TO THE ENVIRONMENT**

The TITANE NEXT commercial door is made with recycled and low-carbon aluminium. It's produced as part of a responsible supply chain, and its design is adapted to a circular economy.

#### **ENHANCED THERMAL PERFORMANCE**

TITANE NEXT will create a comfortable and energy-efficient environment within commercial spaces. It is designed with superior thermal insulation, minimizing heat transfer, and reducing energy consumption during the use phase.

#### **UNCOMPROMISING SECURITY**

TITANE NEXT doors are engineered with robust security features, offering unparalleled strength and protection. With strong frames, multi-point locking systems, and impact-resistant glazing, premises are safeguarded against potential intruders.

#### **LARGE DIMENSIONS**

TITANE NEXT door comes in a range of large dimensions, exceeding industry standards, allowing ample natural light to flood the space, and thus creating a welcoming ambiance for visitors and occupants.

#### **SLEEK DESIGN**

TITANE NEXT doors are crafted with meticulous attention to detail, combining contemporary design with exceptional functionality. Choose from a wide range of colours to customise the look, perfectly enhancing the overall appeal of any commercial property.

#### **LOW MAINTENANCE AND DURABILITY**

TITANE NEXT door is designed for long-lasting durability and minimal maintenance. Crafted from high-quality materials, it is resistant to corrosion, fading and wear.

# FUNCTIONALITY AND AESTHETICS

➤ TITANE NEXT – HIGH TRAFFIC COMMERCIAL DOOR

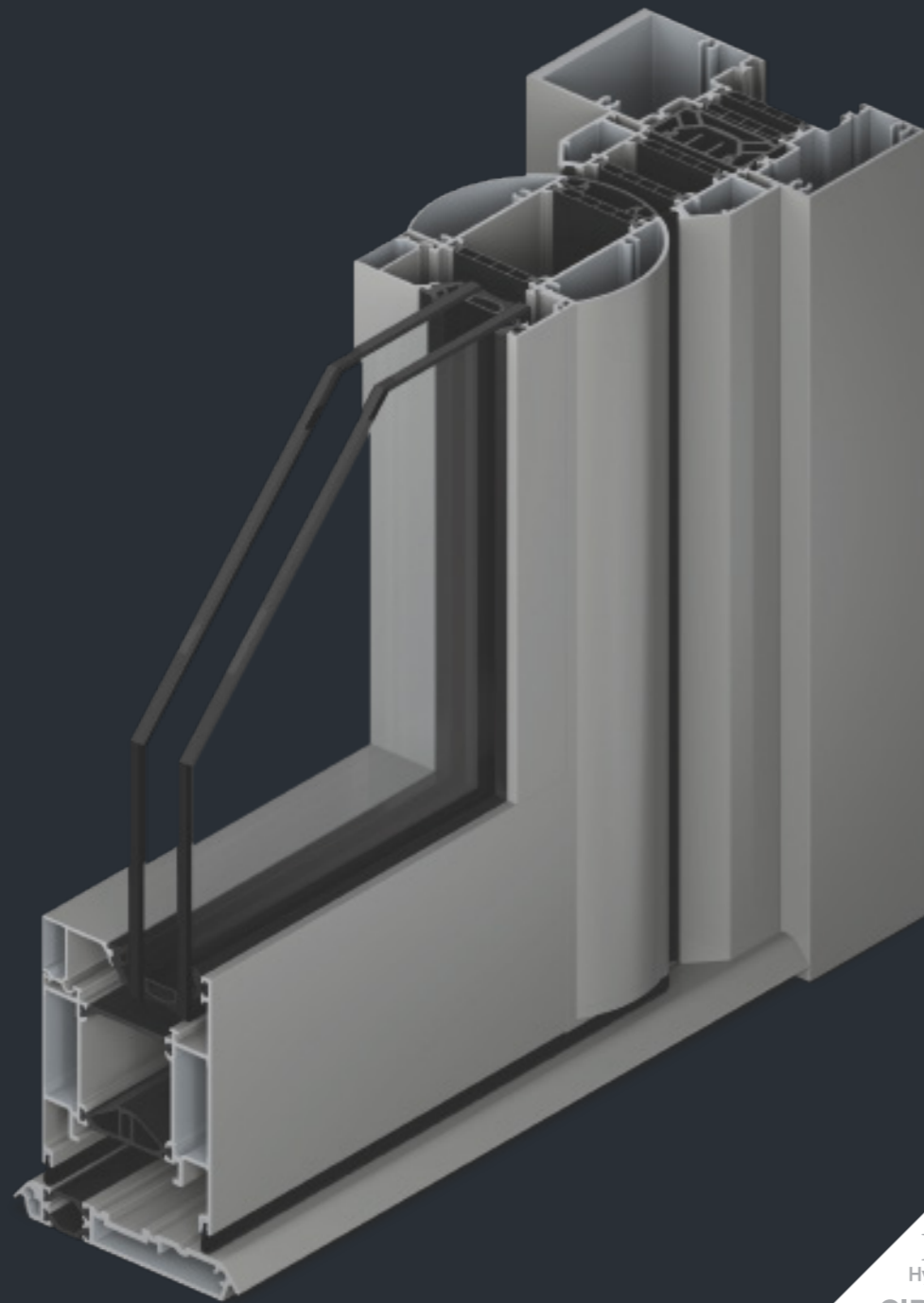

# KEY FEATURES & INNOVATIONS

➤ TITANE NEXT – HIGH TRAFFIC COMMERCIAL DOOR

## DESIGN

- Concealed elements such as hinge, electromagnetic locks, and transom closer
- Full RAL colour palette
- Available with Dual Colour option

## LARGE DIMENSIONS

- Doors:
  - Module: 75 mm
  - Height: up to 3 meters
  - Width: up to 1.2 meters
  - Glazing thickness: up to 60 mm
  - Leaf weight: up to 110 kg
- Fixed parts:
  - Module: 100 mm
  - Height: up to 3 m
  - Glazing thickness:
    - Pocket rebate up to 32 mm
    - Open rebate up to 46 mm
  - Glass infill weight: up to 200 kg

## APPLICATIONS

- Standard door, double action, 1 leaf or 2 leaves
- Panic exit door, single action, 1 leaf or 2 leaves
- Door with electro-magnetic lock, single action, 1 leaf or 2 leaves
- Side light and other composite framing options

## SAFETY & ACCESSIBILITY

- Low threshold 15 mm
- Panic exit door according to EN1125
- Anti-finger-pinching protection system on the pivot side
- Burglary resistance PAS24
- Electromagnetic locks (optional)

## PERFORMANCES

- Endurance test for heavy traffic on transom closer: up to 500,000 cycles
- Thermal insulation:  $U_w =$  up to  $0.79 \text{ W/m}^2\text{K}$
- Weather performance complying to international standards:
  - Air permeability: up to A2
  - Water tightness: up to 3A
  - Wind resistance: up to C3

## SOFTWARE

- Available in TechDesign

## SUSTAINABILITY

- Available in Hydro CIRCAL®, an aluminium made with a minimum of 75% recycled end-of-life aluminium. This aluminium has one of the lowest CO2 footprints worldwide: 1.9 kg of CO2 /kg aluminium.
- PVC-free components
- Dynamic EPD available in TechDesign
- 75% recycled and 95% recyclable components
- Easy to dismantle for recycling at end of product lifecycle

# FLAWLESS SECURITY, ACCESSIBILITY FOR ALL

## ➤ TITANE NEXT – HIGH TRAFFIC COMMERCIAL DOOR

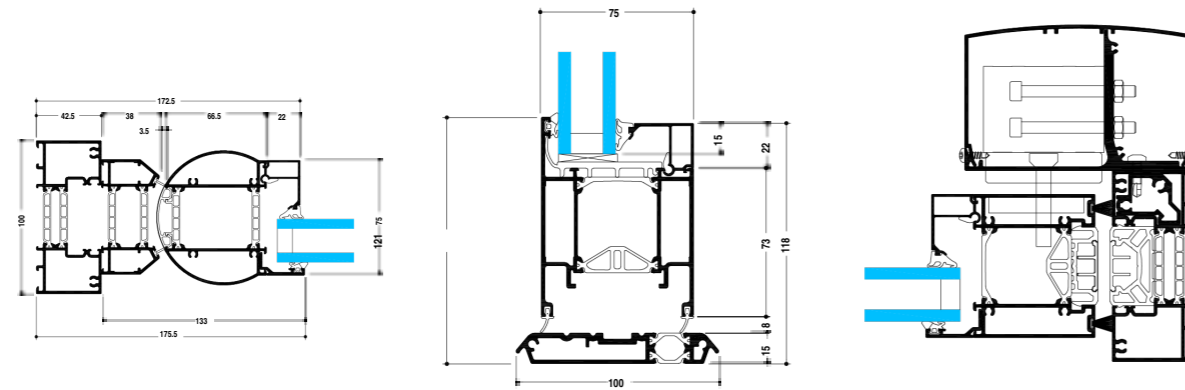

Anti-finger trap safety stile

Low threshold 15 mm

Integrated electro magnetic lock

### SAFETY

TITANE NEXT doors are engineered with robust safety features, offering strength and protection:

- Burglary resistance level: PAS 24
- Finger-protection safety stile
- Panic and emergency escape locks handles, and push bars conforming to EN 1125

### LOCKS

- Single-point locks
- Multiple single point locks
- Electro-magnetic lock:
  - Integrated into the system with a pull-resistance up to 750 kg by magnet
  - Flexibility in access control
- Can be combined with locks with night latch

### ACCESSIBILITY

The disabled access threshold for the TITANE NEXT door maintains high weather performance.

Drainable threshold as low as 15 mm for easy access to people with disabilities or reduced mobility.

# APPLICATION

## ➤ TITANE NEXT – HIGH TRAFFIC COMMERCIAL DOOR

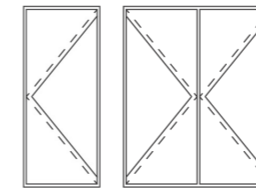

Stand-alone

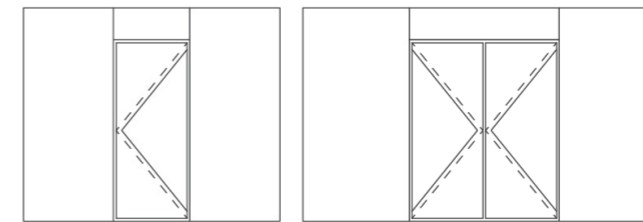

Compositions with fixed light

### COMPOSITIONS WITH FIXED LIGHT

TITANE NEXT has its own framing solution, simplifying the creation of side light and other composite framing options.

The door and side light can share a continuous threshold for improved aesthetics.

For improved thermal performance, the glass thickness for pocket rebate can go up to 32 mm (double glazing), and up to 50mm (triple glazing) for open rebate.

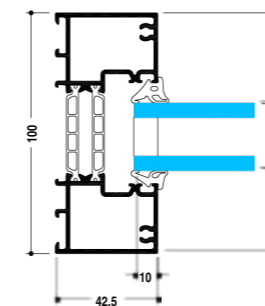

Pocket framing for glass up to 32 mm

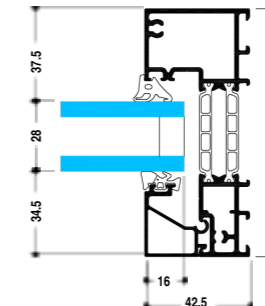

Open rebate for glass up to 51 mm



Architect: Austin-Smith:Lord LLP  
Photographer: A2N Management

### QUICK AND EASY TO ASSEMBLE

The TITANE NEXT door and shopfront were designed to be quick and easy to fabricate, allowing fabricators to save time.

- Multiple innovative profile connection solutions, quick and easy to assemble
- Straight cut assembly
- Specific mullion box profiles simplify assembly and increase strength for larger spans
- Half mullion profiles allow for composite frames to be factory fabricated and coupled together on site
- Outside glazing, easier to install versus inside glazing for fixed parts
- Locks integrated in the insulation area for easy machining
- Unique new low threshold profile designed to run the full width of an opening, under both doors and frame for simplified fabrication and installation

# FUNCTIONAL DESIGN

## ➤ TITANE NEXT – HIGH TRAFFIC COMMERCIAL DOOR



- TITANE NEXT doors are crafted with meticulous attention to detail, combining contemporary design with exceptional functionality. Choose from a wide range of finishes to customise the look, enhancing the overall appeal of any commercial property.
- Transom and bottom pivot closer integrated in the door structure, making them invisible and more aesthetically pleasing
- Door stile end mouldings provide an improved finish and allow a continuous seal across the bottom of the door
- Discreet electromagnetic lock, integrated in the system
- Many ways to customise with colours and handles: profiles available with dual colour option

Architect: David Hughes Lawry Architects  
Photography: A2N Management

# HANDLES

## ➤ TITANE NEXT – HIGH TRAFFIC COMMERCIAL DOOR

### PUSH BAR

Easy to manipulate, the push bar is compatible with all applications of TITANE NEXT.



**ROUND INOX PUSH BAR**  
Stainless Steel

### T SHAPE HANDLE

The timeless design of the stainless-steel T shape handle.

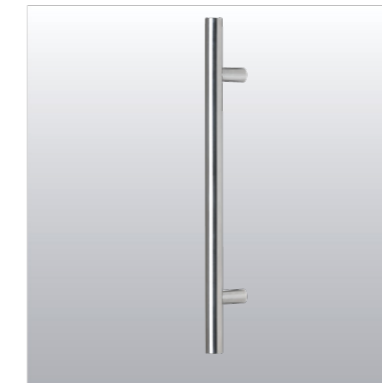

**T SHAPE HANDLE**  
Stainless Steel

### HANDLE FOR MAGNETIC LOCK

This handle can be combined with the magnetic lock which is integrated in the system.

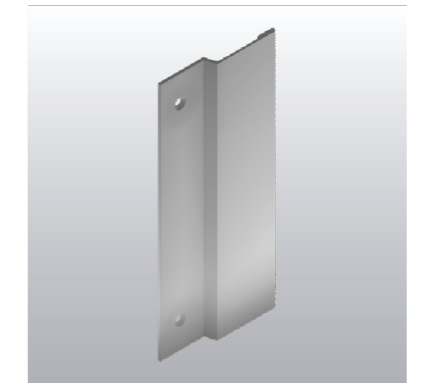

**HANDLE FOR MAGNETIC LOCK**  
Can be coated

### PULL HANDLES

Our exclusive design pull handles are robust and available in a range of different colours.

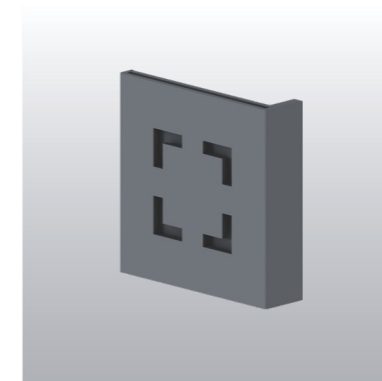

**PULL HANDLE**  
Can be coated



**FULL HEIGHT PULL HANDLE**  
Can be coated

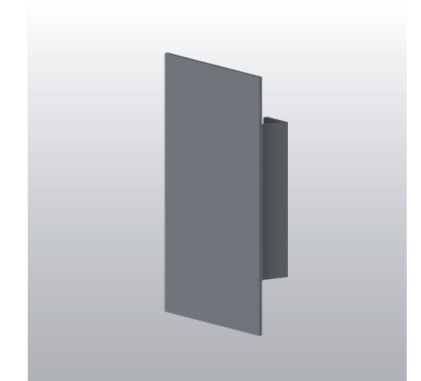

**PULL HANDLE**  
Can be coated



## LESS IMPACT

➤ IMAGINE BEYOND LIMITS

The building and construction sector represents 39% of global energy-related carbon emissions.

The carbon footprint of a building is made of two stages:

**USE:** "operational" emissions caused by heating, cooling... and

**CONSTRUCTION:** "upfront" emissions caused by materials extraction and production, delivery, waste management...

We go beyond materials to provide you with high-performance and circular products which contributes to reducing the carbon emissions caused in the **use** phase.

At the same time we go beyond products to focus on upfront emissions, to contribute to the reduction of carbon emissions during both the **production and construction** phase.

# COMMITMENT AND SUSTAINABILITY

## DRIVING DECARBONISATION PATHWAY

TECHNAL demonstrates its strong commitment to the environment in all areas: by using recycled and low-carbon materials, with a product design that is adapted to a circular economy, and produced within a responsible supply chain. In addition, these statements are certified by external organisations to ensure maximum transparency.

### HYDRO CIRCAL®

We are demonstrating our focus on sustainability by using Hydro CIRCAL® for our system solutions, one of the most sustainable aluminium alloys in our sector. Hydro CIRCAL® is a range of prime quality aluminium made with a minimum of 75% recycled end-of-life aluminium (post-consumer scrap). Hydro CIRCAL® also has **one of the smallest CO<sub>2</sub> footprint worldwide: 1.9 kg CO<sub>2</sub> per kg of aluminium** – 85% of reduction vs the world global primary average.

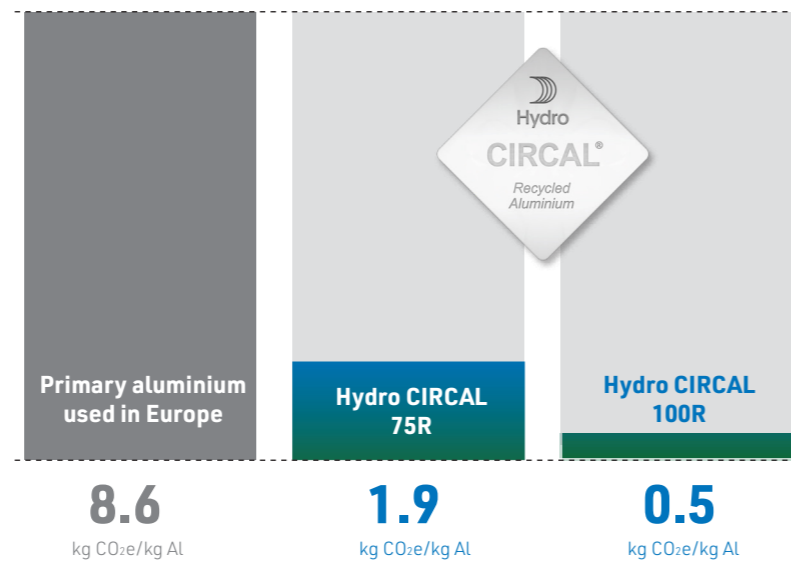

### OUR CERTIFICATIONS



Tental 60 has been certified Cradle to Cradle silver.



100% of our extrusion plants are ASI Performance Standard Certified.



Thanks to TechDesign, it's possible to generate a dynamic EPD according specified dimensions, applications any type of glazing.



### 75% RECYCLED ET 95% RECYCLABLE CONTENT

Following our path to the certified circular economy, all of our systems are composed with a majority of materials and components that can be infinitely recyclable, that can come from recycled raw materials, that can be recycled to have a second life or components that can also be reused.

In rough figures, we're talking about **75% recycled content and 95% recyclable content**. It's an efficient way to drastically reduce the impact of materials on the life cycle of a building. Finally, our greener approach goes a step further thanks to recycled thermal strips for 75 mm modules.

### TARGET 2025 VS 2018: CO<sub>2</sub> COMPANY EMISSIONS DIVIDED BY 2

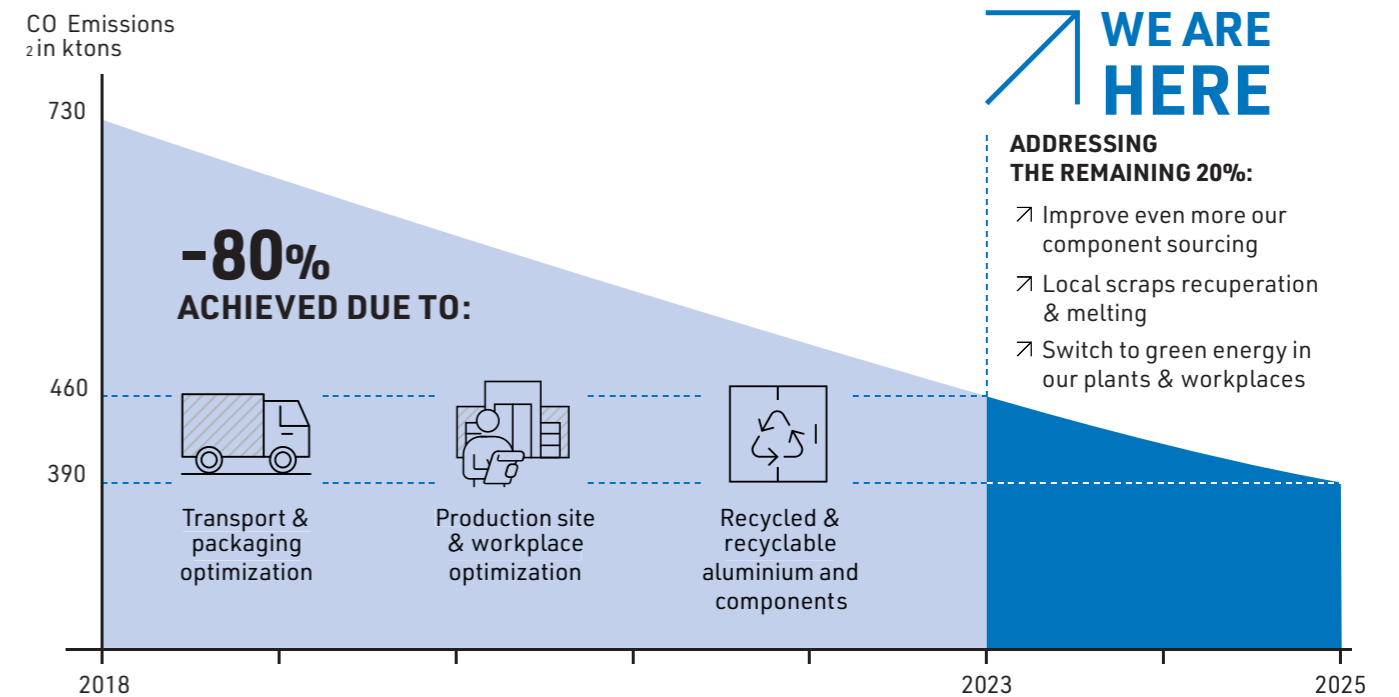

# WEATHER AND RESISTANCE PERFORMANCES

## ➤ TITANE NEXT - HIGH TRAFFIC COMMERCIAL DOOR

TITANE NEXT   THERMAL PERFORMANCES $U_d$ (W/m <sup>2</sup> K)					
Application	Dimensions W x H (mm)	with $U_g = 1.0$ (double glazing 28 mm)	*with $U_g = 0.7$ (triple glazing 36 mm)	with $U_g = 0.6$ (triple glazing 42 mm)	with $U_g = 0.5$ (triple glazing 48 mm)
Door + Shopfront	5200 x 2500	1.2 W/m <sup>2</sup> K	0.96 W/m <sup>2</sup> K	0.87 W/m <sup>2</sup> K	0.79 W/m <sup>2</sup> K
Door	1250 x 2500	1.5 W/m <sup>2</sup> K	1.3 W/m <sup>2</sup> K	1.2 W/m <sup>2</sup> K	1.2 W/m <sup>2</sup> K
Door	1230 x 2180	1.6 W/m <sup>2</sup> K	1.4 W/m <sup>2</sup> K	1.3 W/m <sup>2</sup> K	1.2 W/m <sup>2</sup> K

TITANE NEXT   WEATHER PERFORMANCES (WWA)					
Application	Report	Dimensions W x H (mm)	Air permeability	Water tightness	Wind
Single double action door		1250 x 2500	A2	3A (100 Pa)	C3
Fixed partitions pocket framing	FCBA -403-22-0575-A-1-VE1	3024 x 3134	A4	E900	A5
Fixed partitions open rebate	FCBA -403-23-0332-A-1-VE1	3105 x 3000	A4	E900	A2





IMAGINE WHAT'S NEXT

Head Office  
Severn Drive, Tewkesbury  
Gloucestershire  
GL20 8SF

Tel+44 1684 853500

Northern Office  
Cedar Court Office Park,  
Denby Dale Road, Wakefield  
WF4 3FU

[info.uk@hydro.com](mailto:info.uk@hydro.com)

London Office  
The Building Centre  
26 Store Street, London  
WC1E 7BT

[www.technal.co.uk](http://www.technal.co.uk)

