

## **The Elsevier DTD 5 Family of XML DTDs**





ELSEVIER

**Tag by Tag**  
**The Elsevier DTD 5 Family of**  
**XML DTDs**

**Bill Bernickus, Jos Migchielsen,**  
**Simon Pepping and Rob Schrauwen**

**Version 1.3.0**

**April 21, 2009**

*Correspondence to:*

Rob Schrauwen  
VP, Director of Central Application Management, Operations  
Elsevier  
Radarweg 29  
1043 NX Amsterdam  
Netherlands  
Email: [r.schrauwen@elsevier.com](mailto:r.schrauwen@elsevier.com)

The authors are members of Elsevier's DTD Development & Maintenance Team. That team is responsible for development, maintenance and support of the Elsevier DTDs and XML schemas. Comments about the DTDs and their documentation, as well as change requests, can be sent to the team. Change requests will be considered for implementation in a future DTD.

The Elsevier DTDs, schemas, and a fully clickable PDF file of this documentation are available via <http://www.elsevier.com/locate/xml>.

Elsevier, a Reed Elsevier company, is an integral partner with the scientific, technical and health communities, delivering superior information products and services that foster communication, build insights, and enable individual and collective advancement in scientific research and health care.

<http://www.elsevier.com>

© 2003–2009 Elsevier B.V. All rights reserved. This document may be reproduced and distributed in whole or in part in any medium, physical or electronic, so long as this copyright notice remains intact and unchanged on all copies. It may not be redistributed, wholly or in part, under terms more restrictive than those under which it has been received.

While every precaution has been taken in the preparation of this book, neither the authors nor Elsevier assume responsibility for errors or omissions.

Many of the designations used by the manufacturers and sellers to distinguish their products are claimed as trademarks. Where those designations appear in this book, and the authors were aware of a trademark claim, the designations have been marked.

This document was typeset using pdf $\text{\TeX}$  and the current  $\text{\TeX}$ Live distribution.

# Contents

<b>Chapter 1. Introduction</b> . . . . .	3
<b>Chapter 2. Technical aspects</b> . . . . .	7
The setup of the DTD family . . . . .	8
The XML file . . . . .	12
Entities and the DOCTYPE declaration . . . . .	14
An XML file's DTD version and catalogs . . . . .	15
Namespaces in the XML file . . . . .	17
Elsevier's additional glyphs . . . . .	26
Strip-in images . . . . .	30
<b>Chapter 3. Journal Article DTD</b> . . . . .	31
PITs: Journal article publication item types . . . . .	56
<b>Chapter 4. Serial Issue DTD</b> . . . . .	59
<b>Chapter 5. Book DTD</b> . . . . .	93
<b>Chapter 6. The Common Element Pool</b> . . . . .	147
Versions of the common element pool . . . . .	148
Cross-references and the ce:label element . . . . .	151
Text effects . . . . .	155
Parameter entities . . . . .	158
ISO 639 list of language codes . . . . .	162
Views . . . . .	163
<b>Chapter 7. The Elements of the CEP</b> . . . . .	167
Alphabetical listing of all elements . . . . .	168
<b>Chapter 8. Structured bibliographic references</b> . . . . .	393
Bibliographic references — Examples . . . . .	394
Alphabetical listing of all elements . . . . .	409
<b>Chapter 9. MathML</b> . . . . .	445
Usage of MathML elements and attributes . . . . .	446
<b>Chapter 10. (Extended) CALS tables</b> . . . . .	451
CALS tables — Examples . . . . .	454
CALS table elements . . . . .	462
Ornament types and styles . . . . .	471
<b>Index</b> . . . . .	475



# Chapter 1

## Introduction

This is the documentation of the family of Elsevier's DTD 5 family of XML DTDs. This family is centred around the common element pool (CEP). In this version of the documentation, the following members of the family are described:

- the journal article (JA) DTD versions 5.0.1, 5.0.2 and 5.1.0;
- the serial issue (SI) DTD 5.1.0;
- the EHS Book DTD versions 5.1.0 and 5.1.1;
- the Elsevier Book DTD versions 5.2.0, 5.2.1 and 5.3.0;
- the common element pool (CEP) versions 1.1.0–1.1.6.

### Historical remarks

Elsevier has a long tradition of using SGML (Standard Generalized Markup Language) for its products. In the 1980s, the CAPCAS DTD (Document Type Definition) was created to capture article frontmatters. In 1992, the first DTD for full-length scientific articles was developed [2].

CAP (Computer-Aided Production) started as a project in the 1990s, and is now the regular production method for Elsevier's more than 1800 STM (science, technology and medical) journals and an increasing number of books, including all major reference works and book series. The consequence of CAP is that journal articles and book chapters are produced as full-text XML, and XML drives both the printed journals and books as well as the online versions on Elsevier platforms such as ScienceDirect (<http://www.sciencedirect.com>) and MDConsult (<http://www.mdconsult.com>), as well as many other platforms. Abstracts are extracted from the XML and find their way to destinations such as Scopus (<http://www.scopus.com>) and PubMed (<http://www.ncbi.nlm.nih.gov>).

Large-scale implementation of the "SGML-first workflow" began with the release of the full-length article DTD 3.0 in November 1995 and continued with the implementation of DTD 4.1, released in November 1997. Updates followed in February 2000 (DTD 4.2) and January and March 2001 (DTD 4.3). As from June 2005, SGML for journal articles was replaced by XML.

The DTDs 4.1–4.3 were described in the previous edition of the *Tag by Tag* [5].

### DTD 5.0

The next generation of DTDs are XML DTDs. These were developed in 2001 and 2002. The business reasons for developing a new family of DTDs were as follows.

- The DTDs should cover all types of content, not just journal articles, but also book content, secondary publishing content, etc. They should be accompanied by new transport formats in the form of W3C schemas.

- The DTDs should be in XML.
- The DTDs should adopt Unicode. Unicode has become the standard for character sets. In the STIX project, Elsevier participated in order to ensure that the characters in the Elsevier Grid were represented in Unicode, although the chemical symbols were left out.
- The DTDs should incorporate MathML. The previous DTDs possessed their own, bespoke fragment for mathematical formulae. Some modifications were needed.
- The DTDs should incorporate CALS tables. CALS tables are widely used in other DTDs and software components for it are available. We have chosen the OASIS Exchange Format, and “extended CALS” tables had to be developed so that all tables occurring in STM articles can be captured.
- The DTDs should follow other XML standards. Where possible, and deemed useful, we have adopted the XLink standard, and we have used standard attribute names such as `xml:lang`.
- The DTDs should be more restrictive (in other words, more precise). The DTD has traditionally been very loose, meaning that it allowed constructs such as tables within footnotes within the first name of an author. Such constructs were prevented by semantic rules, enforced by the SGML quality control tools.

Adopting common international standards has not been without problems. Unicode contains a wealth of symbols, but at the time of introduction of the DTD, it lacked a number of symbols such as the chemical symbols present in the Elsevier Grid. MathML does not allow any parametrization. In particular, text portions appearing in displayed formulae cannot be structured—they must be plain characters. CALS tables turned out to be too poor for all varieties of tables encountered in scientific articles. Our desire to retain an “SGML/XML-First” workflow, i.e., a workflow in which the SGML/XML file is used to create all the products, be it print or electronic (see below), necessitated the introduction of table extensions. The fact that the CALS table model has no provision for namespaces complicated matters. In all these cases we were forced to modify the standards, with the risk of losing the benefits of adopting those standards.

The name “full-length article DTD” has been replaced by the more accurate name “journal article DTD”.

In order to maintain a consistent set of XML DTDs, the concept of a *common element pool* was introduced, described in more detail later. The individual DTDs make use of this pool.

Additionally, a distinction is made between *input* and *output* DTDs, where “input” and “output” relate to Elsevier’s Electronic Warehouse. The input DTD is geared towards supplying XML documents, whereas the output DTD facilitates rendering using stylesheets—the latter features, for instance, information about height and width of figures.

The project to create and implement the DTD 5 family of DTDs was called “Hawaii 5.0”.

### How to read this documentation

This documentation is not intended as an introduction into XML. It is assumed that the reader is familiar with XML terminology, and can read XML fragments.

This documentation alone is not sufficient to describe electronic deliveries to and from Elsevier. It should be read together with

- the Guide for MFC activities, containing copy-edit instructions;
- the Typographic Standardization and the journals’ typesetting instructions, containing the default rendering of the SGML/XML files on paper;



- Electronic Warehouse input and output specifications, detailing the structure of electronic datasets.

### **CAP, CAPLite, CAPLitePlus**

A CAP delivery of an item contains a PDF file (Portable Document Format from Adobe) and an XML file capturing the full item as well as all external files (“assets”) referred to from the XML file.

For some types of content, e.g. camera-ready journals, delivery of full-article XML is not a viable alternative. For these types of content, the full-article PDF file is required, but only the head and the tail are captured in XML (the definition of “head” and “tail” are given in later chapters). In total, four varieties of XML capturing are distinguished:

- CONTENTS-ENTRY-ONLY. Only the title and authors are captured, also known as “ultralight” deliveries.
- HEAD-ONLY. Only the head is captured, also known as “CAPLite” deliveries.
- HEAD-AND-TAIL. Only the head and the tail are captured, also known as “CAPLite-Plus” deliveries.
- Full CAP: the whole article is captured.

The DTDs support these different “XML manifestations”, and they are also dealt with in this documentation. Fortunately, these manifestations limit themselves to a small number of publications.

There is a difference between a HEAD-ONLY document and a full CAP document that only contains a head. In the latter case, one can be sure that the document is nothing more than the head. In the former case a body and a tail may or may not have been present. Interpreting the XML file and concluding the file is HEAD-ONLY is therefore wrong. It must be concluded from the manifestation type indicated by the dataset description.

### **SGML/XML First**

The core principle of the CAP workflow has always been “SGML/XML First”. This means that all products, be it online or in print, are derived from the same source SGML/XML file. The PDF files used for print are as much derived from the XML as the online product.

If one would define XML First as “Give a valid XML file to any supplier, then each supplier will produce the same PDF file”, one can say that XML First is achieved for the majority of journal titles. For some nonstandard titles, and for some book projects, the layout requirements are so important that full compliance to the XML First Principle is not always possible.

For PreCAP, where printed journal issues are scanned and delivered electronically, the principle obviously does not apply.



## Chapter 2

# Technical aspects

This chapter contains technical details of the Elsevier DTD family and the XML files that are structured according to these DTDs.

- The first section, [The setup of the DTD family](#) (p. 8), describes the general set-up of the DTD 5.0 family, with several DTDs calling in the common element pool, which in turn uses the MathML and CALS DTDs.
- The second section, [The XML files](#) (p. 12), explains general rules for each XML file, such as its UTF-8 encoding and whitespace rules.
- Each XML file structured according to one of the Elsevier DTDs begins with a doctype declaration and the declaration of external entities, if any. This is described in the third section, [Entities and the DOCTYPE declaration](#) (p. 14).
- The fourth section, [The DTD version of an XML file and catalogs](#) (p. 15), stresses that the authoritative version of the DTD with which an XML file is structured is found using the public identifier in the doctype declaration.
- Extensive use of namespaces has been made. This is detailed in the fifth section, [Namespaces in the XML file](#) (p. 17).
- The Unicode standard misses some crucial symbols that are used in Elsevier's XML files. The additional glyphs are listed in the sixth section, [Elsevier's additional glyphs](#) (p. 26).
- MathML formulae and extended CALS tables are accompanied by a graphical representation, called a strip-in. General rules for strip-ins are described in the final section of this chapter, [strip-ins](#) (p. 30).

## The setup of the DTD family

This section describes the setup of the DTDs, the common element pool and the corresponding namespaces.

In order to manage a family of XML DTDs, a modular approach was adopted. The DTDs belonging to the DTD 5 family use a common element pool (CEP), consisting of elements shared by various DTDs. In turn, the common element pool includes other DTD fragments, e.g. MathML and CALS tables.

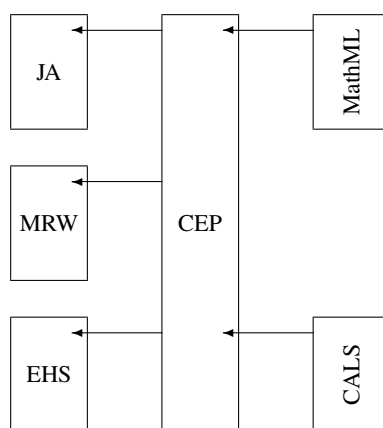

Figure 1: Modular structure of the DTDs

As a result, the individual DTDs are mostly fairly small; they describe the top-level structure of the content. Some DTDs are different by nature, such as the serials issue (SI) DTD and the Elsevier Health Science (EHS) DTD, and therefore use fewer common elements.

### Namespaces

Even though DTDs, unlike, e.g., XML schemas, offer limited support for namespaces, these have been introduced in the DTD 5 family, and these play a role when processing files using namespace-aware software. For instance, XSLT stylesheets are aware of the namespace and unexpected results can be obtained when the namespace is not taken care of. The namespaces are named using URIs — these are abstract names not pointing to any page on the Elsevier corporate website. The following namespaces are the namespaces used in the DTD 5 family.

Namespace identifier	Elements
<a href="http://www.elsevier.com/xml/ja/dtd">http://www.elsevier.com/xml/ja/dtd</a>	JA DTD
<a href="http://www.elsevier.com/xml/si/dtd">http://www.elsevier.com/xml/si/dtd</a>	SI DTD
<a href="http://www.elsevier.com/xml/ehs-book/dtd">http://www.elsevier.com/xml/ehs-book/dtd</a>	EHS Books
<a href="http://www.elsevier.com/xml/bk/dtd">http://www.elsevier.com/xml/bk/dtd</a>	Elsevier Books
<a href="http://www.elsevier.com/xml/common/dtd">http://www.elsevier.com/xml/common/dtd</a>	Core CEP
<a href="http://www.elsevier.com/xml/common/struct-bib/dtd">http://www.elsevier.com/xml/common/struct-bib/dtd</a>	Structured references
<a href="http://www.elsevier.com/xml/common/table/dtd">http://www.elsevier.com/xml/common/table/dtd</a>	CALS extensions
<a href="http://www.elsevier.com/xml/common/cals/dtd">http://www.elsevier.com/xml/common/cals/dtd</a>	OASIS CALS
<a href="http://www.w3.org/1999/xlink">http://www.w3.org/1999/xlink</a>	XLink
<a href="http://www.w3.org/1998/Math/MathML">http://www.w3.org/1998/Math/MathML</a>	MathML

The namespaces existing within the DTD and the common element pool are declared in the top-level element. The MathML namespace is declared in the MathML Qualified Names Module.

The convention is adopted that the elements indigenous to the DTD belong to the default namespace. Therefore within the family of DTDs two different elements with the same name can exist. Namespace-aware processors will treat each variant differently.

The other elements are explicitly prefixed in the DTD: all elements in the common element pool have been given a prefix `ce:` or, for elements for structured bibliographic references, `sb:`, or `tb:` for elements that extend the CALS table model. The MathML elements have been assigned a prefix `mml:`.

An unfortunate exception is formed by the elements in the CALS table fragment. Since that fragment lacks the option to declare a namespace prefix, they all have no prefix, even though they belong to the common element pool. In order to avoid that XML processors treat these elements as belonging to the default namespace of the DTD, the element `ce:table` resets the default namespace to the CALS namespace. The element `entry` resets the default namespace to that of the common element pool.

More details can be found in the section [Namespaces in the XML file](#) (p. 17).

## MathML, CALS

The common element pool pulls in MathML and CALS fragments. It should be noted that it is important to use for these fragments the files belonging to the common element pool distribution, rather than files found elsewhere. These files contain the correct version, corresponding to the Public Identifiers defined in the common element pool.

## Doctypes

In order to make the DTDs more precise, they may contain more than one top-level element, the *doctype*. Other documentation gives instructions about when a certain doctype is appropriate. For instance, `article` and `book-review` are doctypes defined by the journal article DTD (JA DTD). A full-length article begins as follows:

```
<?xml version="1.0" encoding="UTF-8" ?>
<!DOCTYPE article
  PUBLIC "-//ES//DTD journal article DTD version 5.0.1//EN//XML"
  "art501.dtd" []>
<article docsubtype="fla">
```

whereas a book review begins thus:

```
<?xml version="1.0" encoding="UTF-8" ?>
<!DOCTYPE book-review
  PUBLIC "-//ES//DTD journal article DTD version 5.0.1//EN//XML"
  "art501.dtd" []>
<book-review docsubtype="brv">
```

Similarly, the books DTDs contain doctypes (top-level elements) for the chapters, the index, the glossary, and the book “hub”.

### Version numbering

It is likely that development of the individual DTDs will require changes to the common element pool. As a consequence, it is likely that different versions of the common element pool will be in use at any one time. For instance, the major reference works DTD might need version 1.2 of the common element pool, while the journal article DTD does not need an update and continues to use the common element pool version 1.1.

The correct version number of the DTD is found in the public identifier of the DTD. (See the section [The DTD version number and XML catalogs](#), p. 15.) A DTD change that results in a change of the second or third digit will always be a backward compatible one.

In case of a change to the third digit, note that the `version` attributes of the top-level elements do not contain the third digit. Therefore, a file structured according to version 5.2.0 will still parse with version 5.2.1 without any change to the XML file. The only thing an application needs to do is to change the [catalog](#) (p. 14) in such a way that the public identifier of the 5.2.0 DTD points to the 5.2.1 file.

### Backward compatibility and downgradability

After a DTD has gone into production, limitations of backward compatibility and downgradability are put on the DTDs.

*Backward compatibility* means that applications that can handle documents conforming to a certain version, can also handle documents conforming to a previous version.

*Downgradability* means that applications that cannot yet handle documents conforming to a newer version, can downgrade these documents or receive documents already downgraded.

In complex situation where many thousands of web services, tools and applications use the XML content, it is impossible to lockstep migration with a DTD upgrade. Therefore these limitations are needed.

Making an element optional is backward compatible, but it is only downgradable if a default value can be supplied in case the element is not present in an XML file. For instance, when a `city` element in an address were to be made optional, older documents are still valid with the new DTD, but it is virtually impossible to scan the affiliation and automatically tag the city in order to downgrade the file.

Making an optional element mandatory is downgradable but not backward compatible as applications that only know about the new DTD will expect the potentially missing element in the XML file. However, for applications that could already handle the optional element the added precision that the element will henceforth always be present is only helpful.

Adding a new, optional element is both backward compatible and downgradable. Adding a new, mandatory element is neither backward compatible nor downgradable.

Only first-digit changes do not need to be backward compatible or downgradable. The *4.x* DTDs have existed for 6.5 years and the family of *5.x* DTDs will be with us for many years as well.

## The XML file

This section describes various rules about the XML files themselves.

### Valid files

Obviously, the XML file must be a valid XML instance. A consequence is that the file is well-formed: that it contains entities properly closed with a semi-colon, and that the < and & characters are only used as XML markup. The file must begin with the XML version declaration including the UTF-8 encoding statement

```
<?xml version="1.0" encoding="UTF-8" ?>
```

Nothing may appear before that statement, between that statement and the DOCTYPE declaration, and after the end tag of the top-level element.

### UTF-8 encoding

Elsevier expects XML files to be delivered in UTF-8 encoding. This encoding, in which each Unicode point is stored as a sequence of one or more bytes, is the only encoding allowed.

Beside the native UTF-8 encoding of the Unicode point, it is also allowed to use explicit character numbers such as `&#x02008;`. Alternatively, the entity name can be used if the entity belongs to one of the ISO characters sets pulled in by the MathML DTD or if it belongs to the ESextra collection. For MathML symbols in Plane One it is required to use math variants.

Hence, the following code results in three times “é”:

```
é &eacute; ; &#x000E9;
```

By the first we mean é in its native UTF-8 encoding. (Note that in that encoding the character is not hex E9 but is encoded as the two-byte sequence C3 A9.)

All these three instances are *identical*. It is wrong to perform character manipulation on a raw XML file: it does not make sense to make a difference between the character entity and the other two variants.

Outside markup, <, " and & are always escaped and present in their pre-defined entity forms `&lt;`, `&quot;`; and `&amp;`;

### Whitespace in the XML file

In this section, “whitespace” refers to the space character (ASCII 32), the linefeed (LF) character (ASCII 10) and the TAB character (ASCII 9). Each of these characters has the same effect: a space in the rendered document.

Unlike the SGML files structured according to DTDs prior to DTD 5, DTD 5 XML files may contain TABs and linefeed characters for ease of reading XML files with the human eye. The carriage-return (CR) character (ASCII 13) is not allowed; line breaks therefore do not follow the MSDOS pattern CRLF.

When a sequence of consecutive whitespace characters appears in an XML file, the effect is as if one space were present. These sequences may only occur at the beginning of a line.

Care should be taken when using whitespace at the beginning or end of mixed-content elements, i.e., with #PCDATA in their content model.



*XML*

```
<ce:caption>
  <ce:simple-para>This is a paragraph ending in a whitespace (the
    linefeed after the full stop); this is not correct.
  </ce:simple-para>
</ce:caption>
```

There are five whitespace characters between “(the” and “linefeed”, which is allowed; they count as one space. The three whitespaces after the full stop, however, are not correct. (It follows from the DTD that the three whitespace characters after `<ce:caption>` are ignored.)

It should be noted that in some of the examples in this documentation, erroneous extra spacing has sometimes been introduced to make the examples easier to read. The close-up sign `␣` is used in that case to make it clear that the XML files should have no spaces or linebreaks at this point.

*XML*

```
<ce:caption>
  <ce:simple-para>The close-up sign indicates that there should
    be no whitespace at the end of the paragraph; the end tag
    is placed on the next line only for reasons of readability.␣
  </ce:simple-para>
</ce:caption>
```

## Entities and the DOCTYPE declaration

The relationship between the XML file and the artwork files and files containing electronic components is made via XML *entities*. These entities are used exclusively in the `ce:link` element and must be declared within the declaration subset of the XML file according to the rules described in this section.

Consider a journal article consisting of an XML file `main.xml`; three artwork files `gr1.jpg`, `gr2.jpg` and `fx1.tif`; an audio file `au1.mp3` and a videoclip `clip.avi`.

The XML file of the article, structured with the journal article DTD, begins like this:

```
<?xml version="1.0" encoding="UTF-8" ?>
<!DOCTYPE article
  PUBLIC "-//ES//DTD journal article DTD version 5.0.1//EN//XML"
  "art501.dtd" [
  <!ENTITY loc1 SYSTEM "gr1" NDATA IMAGE>
  <!ENTITY loc2 SYSTEM "gr2" NDATA IMAGE>
  <!ENTITY loc3 SYSTEM "fx1" NDATA IMAGE>
  <!ENTITY loc4 SYSTEM "au1" NDATA AUDIO>
  <!ENTITY loc5 SYSTEM "clip" NDATA VIDEO>]>
<article docsubtype="fla">
  ...
</article>
```

The entities `loc1`–`loc5` are used in the ENTITY-type attributes of the element `ce:link`. The system names are the file names without extension.

The actual link is established in a three-step process, starting with its usage within the document which looks like this:

```
<ce:biography id="vt1">
  <ce:link locator="loc3"/>
  <ce:simple-para>...</ce:simple-para>
</ce:biography>
```

The `ce:link` element instructs the rendering application to pull in an external file. It is the file referenced through the entity `loc3`, the value of the `locator` attribute, that is declared in the doctype declaration as the external entity with system name (i.e., file name) `fx1`. The *catalog* redirects this to `fx1.tif`.

In the declaration subset (between square brackets), it is only allowed to declare entities of the types NDATA. The notations defined in the DTD are TEXT, reserved for plain text; IMAGE, reserved for artwork formats such as GIF, JPEG and TIF; AUDIO, reserved for audio formats such as MP3, MP4 and WAV; VIDEO, reserved for video formats such as AVI, MP4 and MPEG; APPLICATION, reserved for documents for other applications or for scripts and executables; and XML, reserved for external XML files, e.g. for scalable vector graphics or chemical object notations. (Not all these notations are currently used.) Precisely those entities needed in the document must be declared.

Applications that wish to check whether all external files are present should examine the declaration subset of the XML file and verify these against the dataset.

Obviously, only files referred to from the XML file are declared as entities as described above. Other files belonging to the item, such as PDF files, are not mentioned in the XML file.

## An XML file's DTD version and catalogs

It is expected that the public identifier in the DOCTYPE declaration of the XML file is used to retrieve the DTD as well as its version number. The `version` attribute of the top element should not be used as it only contains the first two digits of the DTD version number for reasons of backward compatibility (p. 8).

*XML*

```
<!DOCTYPE simple-article
PUBLIC "-//ES//DTD journal article DTD version 5.0.1//EN//XML"
"art501.dtd">

<!DOCTYPE serial-issue
PUBLIC "-//ES//DTD serials issue DTD version 5.1.0//EN//XML"
"si510.dtd">

<!DOCTYPE ehs-book
PUBLIC "-//ES//DTD ehs book DTD version 5.1.1//EN//XML"
"ehs_book511.dtd">

<!DOCTYPE book
PUBLIC "-//ES//DTD ehs book DTD version 5.2.1//EN//XML"
"book521.dtd">

<!DOCTYPE converted-article
PUBLIC "-//ES//DTD journal article DTD version 4.5.2//EN//XML"
"art452.dtd">
```

The string after the keyword PUBLIC contains the DTD associated with the XML file that has this DOCTYPE declaration. The system identifier does not contain that information. To map the public identifier to a file on the user's system XML catalogs should be used as explained below.

### XML catalogs

Catalogs are an important tool in entity management: they allow XML tools to locate DTDs and other external files that are used by the XML file. Catalogs make entity management flexible: they allow us to associate system identifiers (file paths and names) to public identifiers, and to rewrite system identifiers.

During the SGML era the SGML Open Catalog (SOC) specification was developed [16]. James Clark's SP suite is a well-known application implementing SOC, and it was the only application that implemented system identifier rewriting.

XML has long done without its own entity resolution system. It had the new rule that even the declaration of a public identifier had to contain a system identifier, which allowed external entity handling to be simple. Some applications continued to use the SOC system. On 6 August 2001 and again on 24 October 2002 OASIS published its XML Catalog specification [17]. It can be seen as a continuation and a refinement of the SOC system. It provides powerful methods to map public identifiers to system identifiers, to rewrite system identifiers, and to modularize catalog management. At the time of this writing several XML toolsets contain implementations of this catalog specification; for an overview see the home page of OASIS' catalog committee [18].

*XML*

```

<?xml version="1.0" encoding="UTF-8" ?>
<catalog xmlns="urn:oasis:names:tc:entity:xmlns:xml:catalog"
  prefer="public">

  <public
    publicId="-//ES//DTD journal article DTD version 5.0.1//EN//XML"
    uri="file:///D:/home/xml/dtd/art500/art501.dtd"/>

  <group xml:base="file:///D:/home/article/">
    <system systemID="gr1" uri="main.assets/gr1.tif"/>
    <system systemID="gr2" uri="main.assets/gr2.tif"/>
  </group>

  <group xml:base="file:///D:/home/xml/dtd/">
    <nextCatalog catalog="mathml/xcatalog"/>
    <nextCatalog catalog="calstable/xcatalog"/>
  </group>

  <rewriteSystem systemIdStartString="file:///D:/home/article/"
    rewritePrefix="file:///G:/datasets/20030310/art5001"/>

</catalog>

```

The above example catalog starts with specifying where the JA DTD can be found. Note that this ignores the system identifier for this DTD in the XML file itself. Also note that this is a local implementation, on other systems the DTD may be located elsewhere.

Then the system identifiers for the images in the XML file discussed above are mapped to an existing file location. Note that a subdirectory is specified and a file name extension is given.

Then two other catalogs are included, for the MathML DTD and the CALS table DTD. This makes it possible to maintain separate catalogs for these subsystems.

Finally some system identifiers are rewritten. Rewriting applies to the start of the system identifier. Here a situation is described where all data for the article have been moved from one place to another.

XML catalogs provide more facilities for entity management. See the specification [17] for details.

Note that using catalogs in this way makes it possible to perform a third-digit update of the DTD by changing the catalog in such a way that the public identifier of the old and new versions both point to the new DTD.

## Namespaces in the XML file

Namespaces are widely used in programming. XML has introduced namespaces to text structuring. Namespaces allow one to reuse commonly used names. For example, the element `title` may have a different content model in one namespace than in another. More importantly, namespaces allow one to group related elements together, and separate them off from other groups of elements.

Namespaces are indicated by their name. In XML, the name is a URI. Usually it is a URL, e.g. `http://www.elsevier.com/xml/common/dtd`. Sometimes it has a rather different form of URI, e.g. `urn:oasis:names:tc:entity:xmlns:xml:catalog`, which is the name of the namespace of an XML catalog.

In an XML document namespaces are indicated by prefixes. A prefix is an alias for a namespace name. Prefixes are defined according to a flexible system. Each element in an XML document may declare prefixes for one or more namespaces using the attribute `xmlns:pfx="name"`, where `pfx` is the newly declared prefix. This prefix is valid for this element and all its descendants, until it is redeclared by another `xmlns` attribute. One may also declare a default namespace, with the attribute `xmlns="name"`. This causes this element, if it does not have a prefix, as well as all its descendants without a prefix, to belong to the declared namespace. When there is no default namespace declaration, all elements without a prefix do not belong to a namespace. One could also say that they belong to the namespace with an empty name.

This flexible system does not fit well into the DTD system. A DTD is not namespace aware. In a DTD the prefix is a fixed part of an element's name. It must be used as determined by the DTD, and cannot be redeclared in the XML document. If one would redeclare a prefix as describe above, the document would become invalid according to the DTD. Some flexibility can be gained by writing the DTD in such a way that the prefix is determined by an entity. This allows one to declare a different prefix at the top of each XML document. The CEP does not use this flexibility, and fixes the prefixes used.

The CEP and the DTDs built on top of it, do all namespace declarations in the DTD, by means of attributes with fixed values. This has the advantage that no namespace declarations are required in the XML document. For a proper understanding that may be a disadvantage, because in the XML document the namespaces are rather invisible. Only by looking up the DTD can one find out in which namespaces the elements live.

In the XML world there are namespace-aware applications and non-namespace-aware applications. DTDs are not namespace aware. For a DTD the prefix is just a part of the element name, and a namespace declaration is an attribute like any other. Parsers may be namespace aware. This makes it possible to inquire in which namespace an element lives. In our first example we make use of this facility.

XSLT processors are namespace aware. They read the DTD and pick up any namespace declarations. Therefore they know in which namespace each element of the XML source document lives, including those without a prefix. If the stylesheet specifies a match with an element, the processor matches the element's name *and* the namespace. If the namespaces are not the same, there is no match. This may sometimes come as a surprise, especially for elements in the default namespace. In our second example we will demonstrate this.

**Example 1**

In this example we first show a short XML document according to the JA DTD. Then we show an outline of the document, and list for each element to which namespace it belongs. Finally we provide some explanation.

The namespace listing in this example was obtained from a SAX2 parser, which reports the namespace URI as the first argument of the callbacks `startElement` and `endElement`.

*XML*

```
<?xml version="1.0" encoding="UTF-8"?>
<!DOCTYPE article
  PUBLIC "-//ES//DTD journal article DTD version 5.0.1//EN//XML"
  "art501.dtd" []>
<article>
  <item-info>
    <jid>aad</jid>
    <aid>16</aid>
    <ce:pii>S0000-0000(03)00002-0</ce:pii>
    <ce:copyright type="society" year="2003">American
      Academy of Dermatology</ce:copyright>
    <ce:doctopics>
      <ce:doctopic>
        <ce:text>Continuing Medical Education</ce:text>
      </ce:doctopic>
    </ce:doctopics>
  </item-info>
  <ce:floats>
    <ce:table id="tbl1" frame="topbot" colsep="0" rowsep="0">
      <ce:label>Table 1</ce:label>
      <ce:caption>
        <ce:simple-para id="sp1">Colours</ce:simple-para>
      </ce:caption>
      <tgroup cols="3">
        <colspec colnum="1" colname="one" colwidth="3*"/>
        <colspec colnum="2" colname="two" colwidth="2*"/>
        <colspec colnum="3" colname="three" colwidth="4*"/>
        <thead>
          <row rowsep="1">
            <entry>Colour 1</entry>
            <entry>Colour 2</entry>
            <entry>Colour 3</entry>
          </row>
        </thead>
        <tbody>
          <row>
            <entry colsep="1"><tb:left-border/>Blue</entry>
            <entry morerows="1" colsep="1"><tb:top-border/>High
              Green</entry>
            <entry><tb:right-border/>Red</entry>
          </row>
          <row>
            <entry colsep="1" colname="one">Red</entry>
            <entry>Blue</entry>
          </row>
        </tbody>
      </tgroup>
    </ce:table>
  </ce:floats>

```

```

        </tbody>
      </tgroup>
    </ce:table>
  </ce:floats>
<head>
  <ce:article-footnote>
    <ce:label>&z.star;</ce:label>
    <ce:note-para>This text was constructed.</ce:note-para>
  </ce:article-footnote>
  <ce:dochead>
    <ce:textfn>Continuing medical education</ce:textfn>
  </ce:dochead>
  <ce:title>Cutaneous photodamage</ce:title>
  <ce:author-group>
    <ce:author>
      <ce:given-name>Sheldon R.</ce:given-name>
      <ce:surname>Pinnell</ce:surname>
      <ce:degrees>MD</ce:degrees>
      <ce:cross-ref refid="aff1">a</ce:cross-ref>
    </ce:author>
    <ce:affiliation id="aff1">
      <ce:label>a</ce:label>
      <ce:textfn>Durham, North Carolina</ce:textfn>
    </ce:affiliation>
  </ce:author-group>
  <ce:abstract>
    <ce:abstract-sec>
      <ce:simple-para>New methods.</ce:simple-para>
    </ce:abstract-sec>
  </ce:abstract>
</head>
<body>
  <ce:sections>
    <ce:section>
      <ce:section-title>Photodamage</ce:section-title>
      <ce:para>Sunlight coupled <ce:cross-ref
        refid="ref1">[1]</ce:cross-ref></ce:para>
    </ce:section>
  </ce:sections>
</body>
<tail>
  <ce:bibliography>
    <ce:section-title>References</ce:section-title>
    <ce:bibliography-sec>
      <ce:bib-reference id="ref1">
        <ce:label>1.</ce:label>
        <sb:reference>
          <sb:contribution>
            <sb:authors>
              <sb:author>
                <ce:surname>Trautinger</ce:surname>
                <ce:given-name>F.</ce:given-name></sb:author>
            </sb:authors>
            <sb:title>

```

```

        <sb:maintitle>Mechanisms of photodamage</sb:maintitle>
      </sb:title>
    </sb:contribution>
    <sb:host>
      <sb:issue>
        <sb:series>
          <sb:title>
            <sb:maintitle>Clin Exp Dermatol</sb:maintitle>
          </sb:title>
          <sb:volume-nr>26</sb:volume-nr>
        </sb:series>
        <sb:date>2001</sb:date>
      </sb:issue>
      <sb:pages>
        <sb:first-page>573</sb:first-page>
      </sb:pages>
    </sb:host>
  </sb:reference>
</ce:bib-reference>
</ce:bibliography-sec>
</ce:bibliography>
</tail>
</article>

```

The following table shows the namespaces with which the elements of the article are associated. In the right column the name of the namespace is given. Here the string `http://www.elsevier.com/xml/`, which is common to all namespace names in the CEP and the DTDs built on top of it, has been omitted for brevity. In the left column the element name is given. Here the structure of the article is indicated by indentation. If an element is indented with respect to a previous element, it is contained in that element.

See the explanation below the table.

Element	Namespace
article	ja/dtd
item-info	ja/dtd
jid	ja/dtd
aid	ja/dtd
ce:pii	common/dtd
ce:copyright	common/dtd
ce:doctopics	common/dtd
ce:doctopic	common/dtd
ce:text	common/dtd
ce:floats	common/dtd
ce:table	common/dtd
ce:label	common/dtd
ce:caption	common/dtd
ce:simple-para	common/dtd
tgroup	common/cals/dtd
colspec	common/cals/dtd
colspec	common/cals/dtd
colspec	common/cals/dtd
thead	common/cals/dtd



Element	Namespace
row	common/cals/dtd
entry	common/dtd
entry	common/dtd
entry	common/dtd
tbody	common/cals/dtd
row	common/cals/dtd
entry	common/dtd
tb:left-border	common/table/dtd
entry	common/dtd
tb:top-border	common/table/dtd
entry	common/dtd
tb:right-border	common/table/dtd
row	common/cals/dtd
entry	common/dtd
entry	common/dtd
head	ja/dtd
ce:article-footnote	common/dtd
ce:note-para	common/dtd
ce:dochead	common/dtd
ce:textfn	common/dtd
ce:title	common/dtd
ce:author-group	common/dtd
ce:author	common/dtd
ce:given-name	common/dtd
ce:surname	common/dtd
ce:degrees	common/dtd
ce:cross-ref	common/dtd
ce:affiliation	common/dtd
ce:label	common/dtd
ce:textfn	common/dtd
ce:abstract	common/dtd
ce:abstract-sec	common/dtd
ce:simple-para	common/dtd
body	ja/dtd
ce:sections	common/dtd
ce:section	common/dtd
ce:section-title	common/dtd
ce:para	common/dtd
ce:cross-ref	common/dtd
tail	ja/dtd
ce:bibliography	common/dtd
ce:section-title	common/dtd
ce:bibliography-sec	common/dtd
ce:bib-reference	common/dtd
ce:label	common/dtd
sb:reference	common/struct-bib/dtd
sb:contribution	common/struct-bib/dtd
sb:authors	common/struct-bib/dtd
sb:author	common/struct-bib/dtd

Element	Namespace
ce:surname	common/dtd
ce:given-name	common/dtd
sb:title	common/struct-bib/dtd
sb:maintitle	common/struct-bib/dtd
sb:host	common/struct-bib/dtd
sb:issue	common/struct-bib/dtd
sb:series	common/struct-bib/dtd
sb:title	common/struct-bib/dtd
sb:maintitle	common/struct-bib/dtd
sb:volume-nr	common/struct-bib/dtd
sb:date	common/struct-bib/dtd
sb:pages	common/struct-bib/dtd
sb:first-page	common/struct-bib/dtd

### Explanation

The elements [article](#), [item-info](#), [jid](#), [aid](#), [head](#), [body](#) and [tail](#), which have no prefix, are in the namespace <http://www.elsevier.com/xml/ja/dtd>. This is so because on the [article](#) element the DTD declares the namespace <http://www.elsevier.com/xml/ja/dtd> as the default namespace.

All elements with the prefix `ce` are in the namespace <http://www.elsevier.com/xml/common/dtd>. This concerns most elements in a journal article.

A somewhat complicated situation arises at the `ce:table` element. On this element the DTD declares that the namespace <http://www.elsevier.com/xml/common/cals/dtd> becomes the default namespace. This means all elements below the `ce:table` element which do not have a prefix, belong to the namespace <http://www.elsevier.com/xml/common/cals/dtd>. This applies to the elements [tgroup](#), [colspec](#), [thead](#), [tbody](#) and [row](#). A few elements in the table have the prefix `tb`. This indicates that they are in the namespace <http://www.elsevier.com/xml/common/table/dtd>, which is the namespace of extensions to the CALS table model.

On the [entry](#) element the DTD declares that the namespace <http://www.elsevier.com/xml/common/dtd> becomes the default namespace. Despite the fact that the element [entry](#) does not have a prefix `ce`, it *does* belong to this namespace. This namespace emphasizes the fact that the content model of [entry](#) is determined by the CEP, not by the CALS table model.

Elements with the prefix `sb` only occur in structured references, starting with the top element [sb:reference](#). They are in the namespace <http://www.elsevier.com/xml/common/struct-bib/dtd>. Structured references also contain a few elements that belong to the namespace <http://www.elsevier.com/xml/common/dtd> (prefix `ce`).

### Example 2

In this example we first show a simple XSLT stylesheet, which we apply to the document of example 1. It contains two templates for each of the elements `item-info`, `row` and `entry`, one with and one without prefix. Only one template of each pair will produce a match. Next we show the resulting HTML document. Finally we provide some explanation.

*XML*

```

<?xml version="1.0" encoding="UTF-8"?>
<xsl:stylesheet version="1.0"
  xmlns:xsl="http://www.w3.org/1999/XSL/Transform"
  xmlns:ce="http://www.elsevier.com/xml/common/dtd"
  xmlns:cals="http://www.elsevier.com/xml/common/cals/dtd"
  xmlns:tb="http://www.elsevier.com/xml/common/table/dtd"
  xmlns:mml="http://www.w3.org/1998/Math/MathML"
  xmlns:ja="http://www.elsevier.com/xml/ja/dtd"
  xmlns:sb="http://www.elsevier.com/xml/common/struct-bib/dtd"
  xmlns:xlink="http://www.w3.org/1999/xlink"
>

  <xsl:output encoding="UTF-8" method="html"/>
  <xsl:strip-space elements="*" />

  <xsl:template match="item-info">
    <h2>Item info</h2>
    JID: <xsl:value-of select="jid"/><br/>
    AID: <xsl:value-of select="aid"/><br/>
    PII: <xsl:value-of select="ce:pii"/><br/>
  </xsl:template>

  <xsl:template match="ja:item-info">
    <h2>(JA:) Item info</h2>
    JID: <xsl:value-of select="ja:jid"/><br/>
    AID: <xsl:value-of select="ja:aid"/><br/>
    PII: <xsl:value-of select="ce:pii"/><br/>
  </xsl:template>

  <xsl:template match="row">
    <tr><td>row</td><xsl:apply-templates/></tr>
  </xsl:template>

  <xsl:template match="cals:row">
    <tr><td>cals:row</td><xsl:apply-templates/></tr>
  </xsl:template>

  <xsl:template match="entry">
    <td>entry: <xsl:apply-templates/></td>
  </xsl:template>

  <xsl:template match="ce:entry">
    <td>ce:entry: <xsl:apply-templates/></td>
  </xsl:template>

  <xsl:template match="/">
    <html>
      <body bgcolor="#FFFFFF">
        <xsl:apply-templates/>
      </body>
    </html>
  </xsl:template>

```

```

<xsl:template match="ce:table">
  <table border="1">
    <caption>
      <xsl:value-of select="ce:label"/>
      <xsl:text>. </xsl:text>
      <xsl:value-of select="ce:caption"/>
    </caption>
    <xsl:apply-templates/>
  </table>
</xsl:template>

<xsl:template match="ja:article|ce:floats|ce:simple-para|cals:*">
  <xsl:apply-templates/>
</xsl:template>

<xsl:template match="*" />

</xsl:stylesheet>

```

The following document is the output HTML document. It has been edited for line breaks.

XML

```

<html
  xmlns:xlink="http://www.w3.org/1999/xlink"
  xmlns:sb="http://www.elsevier.com/xml/common/struct-bib/dtd"
  xmlns:ja="http://www.elsevier.com/xml/ja/dtd"
  xmlns:mml="http://www.w3.org/1998/Math/MathML"
  xmlns:tb="http://www.elsevier.com/xml/common/table/dtd"
  xmlns:cals="http://www.elsevier.com/xml/common/cals/dtd"
  xmlns:ce="http://www.elsevier.com/xml/common/dtd">
<body bgcolor="#FFFFFF">
<h2>(JA:) Item info</h2>
  JID: aad<br>
  AID: 16<br>
  PII: S0000-0000(03)00002-0<br>
<table border="1">
<caption>Table 1. Colours</caption>
<tr>
<td>cals:row</td>
<td>ce:entry: Colour 1</td>
<td>ce:entry: Colour 2</td>
<td>ce:entry: Colour 3</td>
</tr>
<tr>
<td>cals:row</td>
<td>ce:entry: Blue</td>
<td>ce:entry: High Green</td>
<td>ce:entry: Red</td>
</tr>
<tr>
<td>cals:row</td>
<td>ce:entry: Red</td>
<td>ce:entry: Blue</td>
</tr>
</table>

```

```
</body>  
</html>
```

### Explanation

The XSLT stylesheet starts by declaring prefixes for all namespaces used in a JA article. It uses the same prefixes as the DTD. This is not required. One is free to use any prefix, regardless of the prefixes used in the source XML document. Of course, selecting the same prefixes adds clarity. Note that the stylesheet also declares a prefix for the namespace `http://www.elsevier.com/xml/ja/dtd`, which is the default namespace in the source XML document. In the stylesheet the default namespace has no name. This is required because its output is an HTML document, which does not use namespaces.

The output HTML document also starts with namespace declarations. The XSLT processor inserts all namespace declarations that it knows of. In this case it is quite useless, but because HTML browsers ignore attributes they do not recognize, it does not harm.

The XSLT stylesheet has two templates for the element `item-info`. One template matches the element in the default namespace. The other template matches the element in the namespace `http://www.elsevier.com/xml/ja/dtd`. Their output is slightly different. The latter template adds the string '(JA:)' to the header.

The resulting HTML document makes it clear that only the template using the `ja` prefix has produced a match. The source document *does* contain an element `item-info` in the `http://www.elsevier.com/xml/ja/dtd` namespace, and it does *not* contain an element `item-info` without a namespace. This is despite the fact that the XML document itself does not show the namespace; the namespace declaration is hidden in the DTD.

Similarly, the XSLT stylesheet contains two templates for the element `row` and two for the element `entry`. Again they produce slightly different output. The resulting HTML file shows again that the templates with a prefix have a match, and those without a prefix do not. In agreement with the table in example 1, we use the `http://www.elsevier.com/xml/common/cals/dtd` namespace for the `row` element, and the `http://www.elsevier.com/xml/common/dtd` namespace for the `entry` element.

## Elsevier’s additional glyphs

Not all symbols used in our publications have been adopted by Unicode. Prior to DTD 5.0, these symbols were part of the “Elsevier Science Grid” [5]. The element `ce:glyph` has been introduced so that we can continue to support these additional symbols.

It is expected that some or all of the glyphs may be added to future versions of Unicode. In that case, it is not an error to use the `ce:glyph` element, but it is preferred that the Unicode character is used.

The list of glyph names allowed in `ce:glyph` is contained in the parameter entity `%glyph-names;`. The following two tables give an overview of the glyph names and the symbols to which they refer. The position refers to the position in the Grid [5]. When a Unicode code point has been assigned to a symbol, it is listed in the column Unicode.

Rendering applications need to store these glyphs, they are not delivered along with the XML files as are [strip-ins](#) (p. 30).

### Glyphs ordered by grid coordinate

Position	Glyph name	Description	Unicode
Bd5	dlcorn	left bottom corner, long	
Bd6	smid	shortmid (Height of small x)	
Bd7	spar	short parallel (Height small x)	
Be5	drcorn	right bottom corner, long	
Be6	nsmid	nshortmid	
Be7	nspar	not short parallel	
Bfp	sqfne	square with filled N-E-corner	
Bfr	sqfsw	square with filled S-W-corner	
Bfv	sqft	square, top filled	
Bfw	sqfb	square, bottom filled	
Bgg	lozfl	lozenge, left filled	
Bgh	lozfr	lozenge, right filled	
Bgi	lozf	lozenge, filled	
Bh8	herma	hermaphrodite	
Bji	S	S-sign	
Bn3	lbd2td	2 bonds on the lefthand side, top double	
Bn4	lbd2bd	2 bonds on the lefthand side, bottom double	
Bn5	rbd2td	2 bonds on the righthand side, top double	
Bn6	rbd2bd	2 bonds on the righthand side, bottom double	
Bo0	rad	radical dot	
Bo1	pent	pentagon	
Bo3	pdbtd	partial double bond, top dashed	
Bo5	ptbtd	partial triple bond, top dashed	
Bo6	ptbdb	partial triple bond, bottom dashed	
Bo7	sbnd	single bond	
Bo8	pdbond	Partial double bond	
Boq	dbnd	double bond; length as m-dash	
Bor	tbnd	triple bond; length as m-dash	
Bos	qbnd	quadruple bond; length as m-dash	
Bpq	dbnd6	6-point double bond; length half of m-dash	
Bpr	tbnd6	6-point triple bond; length half of m-dash	
Bps	qbnd6	six-point quadruple bond; length half of m-dash	

Position	Glyph name	Description	Unicode
Bpt	rbond3	3 bonds on the righthand side	
Bpu	lbond3	3 bonds on the lefthand side	
Bpv	rbond2	2 bonds on the righthand side	
Bpw	lbond2	2 bonds on the lefthand side	
Buc	camb	Cambrian (era)	
Can	bigdot	big dot above (accent)	
Cfi	jnodot	undotted l.c. j	
Pa8	ht	hooktop (phonetic symbol)	
Pb6	ggrave	extra low, accent (phonetic symbol)	
Pb8	ctl	curly tail (phonetic symbol)	
Pc3	sbw	subscript w (phonetic symbol)	
Pc6	hris	high rising, accent (phonetic symbol)	
Pc7	hriss	high rising, symbol (phonetic symbol)	002E6-002E5
Pd3	hbar	horizontal bar (phonetic symbol)	
Pd6	lris	low rising, accent (phonetic symbol)	
Pd7	lriss	low rising, symbol (phonetic symbol)	002E9-002E8
Pdk	resmck	small capital K, reversed (phonetic symbol)	
Pdp	phktp	p hooktop phonetic symbol)	001A5
Pe6	risfla	rising-falling, accent (phonetic symbol)	
Pe7	risfls	rising-falling, symbol (phonetic symbol)	002E6-002E5-002E6
Pfj	jnodot	j, undotted (phonetic symbol)	
Pgh	hrtrh	turned h, hook right tail (phonetic symbol)	
Phn	ncurt	curly-tail n (phonetic symbol)	
Pht	tcurt	curly-tail t (phonetic symbol)	
Pid	dcurt	curly-tail d (phonetic symbol)	
Pih	heng	heng (phonetic symbol)	
Pj1	pSlash	double Slash (phonetic symbol)	
Pk1	trisla	triple Slash (phonetic symbol)	
Pko	trnomeg	inverted omega (phonetic symbol)	
Plr	refhrl	reversed fish-hook r, long leg (phonetic symbol)	
Pt2	btmliq	bottom ligature (phonetic symbol)	

**Glyphs ordered by glyph name**

Glyph name	Position	Description	Unicode
bigdot	Can	big dot above (accent)	
btmliq	Pt2	bottom ligature (phonetic symbol)	
camb	Buc	Cambrian (era)	
ctl	Pb8	curly tail (phonetic symbol)	
dbnd	Boq	double bond; length as m-dash	
dbnd6	Bpq	6-point double bond; length half of m-dash	
dcurt	Pid	curly-tail d (phonetic symbol)	
dlcorn	Bd5	left bottom corner, long	
drcorn	Be5	right bottom corner, long	
ggrave	Pb6	extra low, accent (phonetic symbol)	
hbar	Pd3	horizontal bar (phonetic symbol)	
heng	Pih	heng (phonetic symbol)	
herma	Bh8	hermaphrodite	
hris	Pc6	high rising, accent (phonetic symbol)	
hriss	Pc7	high rising, symbol (phonetic symbol)	002E6-002E5
hrtrrh	Pgh	turned h, hook right tail (phonetic symbol)	
ht	Pa8	hooktop (phonetic symbol)	
jnodot	Pfj	j, undotted (phonetic symbol)	
lbd2bd	Bn4	2 bonds on the lefthand side, bottom double	
lbd2td	Bn3	2 bonds on the lefthand side, top double	
lbond2	Bpw	2 bonds on the lefthand side	
lbond3	Bpu	3 bonds on the lefthand side	
lozf	Bgi	lozenge, filled	
lozfl	Bgg	lozenge, left filled	
lozfr	Bgh	lozenge, right filled	
lris	Pd6	low rising, accent (phonetic symbol)	
lriiss	Pd7	low rising, symbol (phonetic symbol)	002E9-002E8
ncurt	Phn	curly-tail n (phonetic symbol)	
nsmid	Be6	nshortmid	
nspar	Be7	not short parallel	
pdbdtd	Bo3	partial double bond, top dashed	
pdbond	Bo8	Partial double bond	
pent	Bo1	pentagon	
phktp	Pdp	p hooktop (phonetic symbol)	001A5
pSlash	Pj1	double Slash (phonetic symbol)	
ptbdbd	Bo6	partial triple bond, bottom dashed	
ptbdtd	Bo5	partial triple bond, top dashed	
qbnd	Bos	quadruple bond; length as m-dash	
qbnd6	Bps	six-point quadruple bond; length half of m-dash	
rad	Bo0	radical dot	
rbd2bd	Bn6	2 bonds on the righthand side, bottom double	
rbd2td	Bn5	2 bonds on the righthand side, top double	
rbond2	Bpv	2 bonds on the righthand side	
rbond3	Bpt	3 bonds on the righthand side	
refhrl	Plr	reversed fish-hook r, long leg (phonetic symbol)	
resmck	Pdk	small capital K, reversed (phonetic symbol)	
risfla	Pe6	rising-falling, accent (phonetic symbol)	
risfls	Pe7	rising-falling, symbol (phonetic symbol)	002E6-002E5-002E6
S	Bji	S-sign	
sbnd	Bo7	single bond	
sbw	Pc3	subscript w (phonetic symbol)	



Glyph name	Position	Description	Unicode
smid	Bd6	shortmid (Height of small x)	
spar	Bd7	short parallel (Height small x)	
sqfb	Bfw	square, bottom filled	
sqfne	Bfp	square with filled N-E-corner	
sqfsw	Bfr	square with filled S-W-corner	
sqft	Bfv	square, top filled	
tbnd	Bor	triple bond; length as m-dash	
tbnd6	Bpr	6-point triple bond; length half of m-dash	
tcurt	Pht	curly-tail t (phonetic symbol)	
trisla	Pk1	triple Slash (phonetic symbol)	
trnomeg	Pko	inverted omega (phonetic symbol)	

## Strip-in images

Since Elsevier began delivering SGML files for electronic products, the files have been accompanied with graphic representations of SGML expressions that are hard to render. Prior to DTD 5.0, these included all accent constructions, all formulae and all tables. Graphic representations of these constructs are called *strip-ins*. These strip-ins were created by Elsevier's Electronic Warehouse from the SGML source.

Strip-ins should not be confused with graphic images of *symbols* in the Elsevier Grid that cannot be represented in today's HTML-based browsers. Such images, seen on platforms such as ScienceDirect<sup>®</sup>, look the same as strip-ins, but are held in glyph libraries of the platforms. With the adoption of Unicode, graphic representation of symbols will become a thing of the past.

Some constructs in an XML file structured by one of the DTDs of the 5.0 family are still hard to render on today's browsers.

- MathML (Chapter 9) is not yet supported natively in the important browsers that Elsevier's readers use, although we expect that to change in the near future. After some time in which readers switch to the newer version, we can assume that MathML can be rendered without problem. At present, however, we continue to supply strip-ins for the element `mml:math`.
- We expect that native CALS tables (Chapter 10) can be rendered in today's web browsers, but the more complicated extended CALS tables are a different matter. These require complicated border styles or complicated alignment that is not possible. For `tgroup` elements with extensions with the `tb:` prefix, we also supply strip-ins. Unlike strip-ins for math, these strip-ins may well continue to be supplied in the future.

Both the `mml:math` and the `tgroup` elements possess an attribute `altimg` that contains the filename of the strip-in image. Note that unlike other external files, the link is not made via an entity (as described in the section [Entities and the DOCTYPE declaration](#), p. 14).

XML

```
<mml:math altimg="si18.gif">...</mml:math>
<tgroup altimg="si103.gif">...</tgroup>
```

The strip-in images are GIF images of the typeset output found in the PDF file of the document. The GIF images are specified in more detail elsewhere. Some points to note:

- Strip-ins are cropped closely. The current specifications do not allow the baseline to be specified. This is only a potential problem for small inline formulae, not for displayed formulae or tables.
- Strip-ins of displayed formulas look identical to the PDF version, except when a column or page break appears right in the middle of them. So, in a two-column journal they might look narrow and in a one-column journal they will be wider.
- Strip-ins of inline formulas look identical to the PDF version except when a line break happens to appear in the middle of them. The strip-in image will appear unbroken.
- Strip-ins of `tgroups` are always one GIF image, irrespective of the height and width of the table.

## Chapter 3

# Journal Article DTD

This chapter contains an alphabetic listing of the elements in the journal article DTD, JA DTD. This DTD is used for capturing journal articles. It is also applied for structuring chapters of certain types of books, e.g. chapters in volumes of book series.

The JA DTD is the successor of the SGML full-length article DTDs.

The journal article DTD defines four top-level elements: [article](#), [simple-article](#), [book-review](#) and [exam](#).

The serial issue DTD, SI DTD, described in Chapter 4, is a related DTD. It is used for capturing the data belonging to a journal issue or a book series volume.

### CEP version used in this DTD

The journal article DTD versions described in this documentation use different versions of the common element pool, as follows:

Journal article DTD	Common element pool
JA DTD 5.0.1	CEP 1.1.0
JA DTD 5.0.2	CEP 1.1.0.1
JA DTD 5.1.0	CEP 1.1.5

### Parameter entities

The journal article DTD versions 5.0.1 and 5.0.2 locally declare parameter entities [%cross-ref](#); and [%cross-refs](#); to consist of [ce:cross-ref](#) and [ce:cross-refs](#), respectively.

```
<!ENTITY % cross-ref          "ce:cross-ref" >
<!ENTITY % cross-refs        "ce:cross-refs" >
```

As a result, it is impossible to use [ce:intra-ref](#) and [ce:intra-refs](#) in documents structured with these versions of the JA DTD.

This restriction is removed in JA DTD 5.1.0.

# aid

## Declaration

### Model (JA DTD 5.0.1–JA DTD 5.1.0)

```
<!ELEMENT aid ( %string.data; )*>
```

## Description

The element [aid](#) contains the article number of the item.

## Usage

The article ID is captured using [aid](#). Article IDs have no leading zeroes.

## See also

[ce:doi](#), [ce:pii](#), [jid](#)

# article

## Declaration

### Model (JA DTD 5.0.1, JA DTD 5.0.2)

```
<!ELEMENT article ( item-info, ce:floats?, head, body?,
tail? )>
<!ATTLIST article
xmlns CDATA #FIXED %ESJA.xmlns;
version CDATA #FIXED '5.0'
xmlns:ce CDATA #FIXED %ESCE.xmlns;
xmlns:sb CDATA #FIXED %ESSB.xmlns;
xmlns:xlink CDATA #FIXED %XLINK.xmlns;
xml:lang %language; 'en'
docsubtype %docsubtype; "fla">
```

### Model (JA DTD 5.1.0)

```
<!ELEMENT article ( item-info, ce:floats?, head, body?,
tail? )>
<!ATTLIST article
xmlns CDATA #FIXED %ESJA.xmlns;
version CDATA #FIXED '5.1'
xmlns:ce CDATA #FIXED %ESCE.xmlns;
xmlns:sb CDATA #FIXED %ESSB.xmlns;
xmlns:xlink CDATA #FIXED %XLINK.xmlns;
xml:lang %iso639; 'en'
docsubtype %docsubtype; "fla">
```

## Description

The element [article](#) contains a complete journal article or a complete book chapter.

## Usage

The element [article](#) is one of the top-level elements (doctypes) of the JA DTD. It is used for structuring full-length articles and other articles of scientific importance.

There are several attributes of the element, as follows.

- The attribute [docsubtype](#) is the most important one. It defaults to `fla`; its complete list of values is described in the section [Publication item types](#) (p. 56). Under regular production conditions, articles with this attribute set to `chp`, `fla`, `rev`, `sco` or `ssu` will be structured with [article](#). However, a CONTENTS-ENTRY-ONLY full-length article may well be structured using [simple-article](#). The precise rules are described in Electronic Warehouse Input specifications.
- The attribute [xml:lang](#) specifies the language in which the article is written (default English, `en`). See Section 7.5 (p. 162) for an overview of the allowed language codes.
- The fixed attribute [xmlns](#) sets the default namespace for JA elements, and the other fixed attributes beginning with `xmlns:` set the prefix and the namespace of elements used in the DTD, e.g. those of the common element pool ([xmlns:ce](#) and [xmlns:sb](#)) and of the XLink standard ([xmlns:xlink](#)). Since these attributes are fixed, they need not be specified as they are inferred by the parser.
- [version](#) is fixed to the first two digits of the version of the DTD.

See [head](#) for an example article opening.

## Version history

In JA DTDs 5.0.1 and 5.0.2, [xml:lang](#) could only can adopt the values English (en, default) French (fr), German (de), Portuguese (pt), Russian (ru), Spanish (es).

## See also

[book-review](#), [exam](#), [simple-article](#)

# body

## Declaration

### Model (JA DTD 5.0.1–JA DTD 5.1.0)

```
<!ELEMENT body ( ce:nomenclature?, ce:salutation?,
                 ce:sections, ce:acknowledgment?,
                 ce:appendices? )>
<!ATTLIST body
  view %view; 'all'>
```

## Description

The element `body` contains the body of an item.

## Usage

The main part of a document is contained in the body, `body`. It consists of an optional nomenclature (`ce:nomenclature`), an optional salutation (`ce:salutation`), a collection of paragraphs, sections, subsections, etc., contained in `ce:sections`, an optional acknowledgment (`ce:acknowledgment`), and optional appendices contained in `ce:appendices`.

## Light reading

In HEAD-ONLY, HEAD-AND-TAIL and CONTENTS-ENTRY-ONLY deliveries, the body is not fully captured in XML. Such documents may still have a `body`, for instance in order to capture electronic components.

# book-review

## Declaration

### Model (JA DTD 5.0.1, JA DTD 5.0.2)

```
<!ELEMENT book-review      ( item-info, ce:floats?, book-review-
                             head, body?, simple-tail? )>
<!ATTLIST book-review
  xmlns          CDATA          #FIXED %ESJA.xmlns;
  version        CDATA          #FIXED '5.0'
  xmlns:ce       CDATA          #FIXED %ESCE.xmlns;
  xmlns:sb       CDATA          #FIXED %ESSB.xmlns;
  xmlns:xlink    CDATA          #FIXED %XLINK.xmlns;
  xml:lang       %language;     'en'
  docsubtype     %docsubtype;   #FIXED "brv">
```

### Model (JA DTD 5.1.0)

```
<!ELEMENT book-review      ( item-info, ce:floats?, book-review-
                             head, body?, simple-tail? )>
<!ATTLIST book-review
  xmlns          CDATA          #FIXED %ESJA.xmlns;
  version        CDATA          #FIXED '5.1'
  xmlns:ce       CDATA          #FIXED %ESCE.xmlns;
  xmlns:sb       CDATA          #FIXED %ESSB.xmlns;
  xmlns:xlink    CDATA          #FIXED %XLINK.xmlns;
  xml:lang       %iso639;      'en'
  docsubtype     ( brv|err )   "brv">
```

## Description

The element [book-review](#) is used to structure a book review.

## Usage

The element [book-review](#) is one of the top-level elements (doctypes) of the JA DTD. It is used for structuring book reviews.

There are several attributes of the element, as follows.

- The attribute [docsubtype](#) contains the [publication item type](#) (p. 56) The values `brv` and `err` are allowed.
- The attribute [xml:lang](#) specifies the language in which the article is written (default English, `en`). See Section 7.5 (p. 162) for an overview of the allowed language codes.
- The fixed attribute [xmlns](#) sets the default namespace for JA elements, and the other fixed attributes beginning with `xmlns:` set the prefix and the namespace of elements used in the DTD, e.g. those of the common element pool ([xmlns:ce](#) and [xmlns:sb](#)) and of the XLink standard ([xmlns:xlink](#)). Since these attributes are fixed, they need not be specified as they are inferred by the parser.
- [version](#) is fixed to the first two digits of the version of the DTD.

See [book-review-head](#) for an example article opening.



## Version history

In JA DTDs 5.0.1 and 5.0.2, [xml:lang](#) could only adopt the values English (en, default) French (fr), German (de), Portuguese (pt), Russian (ru), Spanish (es).

As of JA DTD 5.1.0, the value `err` is allowed for [docsubtype](#).

## See also

[article](#), [exam](#), [simple-article](#)

## book-review-head

### Declaration

#### Model (JA DTD 5.0.1)

```
<!ELEMENT book-review-head ( ce:article-footnote*, ( ( ce:title,
ce:alt-title* ) | ( ce:dochead,
( ce:title, ce:alt-title* )? ) ),
( sb:reference | ce:other-ref )+,
ce:author-group+, ce:date-received?,
ce:date-revised*, ce:date-accepted?,
ce:miscellaneous? )>
```

#### Model (JA DTD 5.0.2)

```
<!ELEMENT book-review-head ( ce:article-footnote*, ce:markers?,
( ( ce:title, ce:alt-title* ) |
( ce:dochead, ( ce:title, ce:alt-
title* )? ) ), ( sb:reference |
ce:other-ref )+, ce:author-group+,
ce:date-received?, ce:date-
revised*, ce:date-accepted?,
ce:miscellaneous? )>
```

#### Model (JA DTD 5.1.0)

```
<!ELEMENT book-review-head ( ce:article-footnote*, ce:markers?,
( ( ce:label?, ce:title, ce:alt-
title* ) | ( ce:dochead, ce:label?,
( ce:title, ce:alt-title* )? ) ),
( sb:reference | ce:other-ref )+,
ce:author-group+, ce:date-received?,
ce:date-revised*, ce:date-accepted?,
ce:miscellaneous? )>
```

### Description

The element `book-review-head` contains the head or frontmatter of a book review, structured according to `book-review`.

### Usage

The head of a book review consists of the article footnotes (`ce:article-footnote`), markers (`ce:markers`), the document heading (`ce:dochead`), a label (e.g., “Chapter 7”) (`ce:label`), the article title (`ce:title`), a sequence of titles each in an alternative language (`ce:alt-title`), a list of structured and unstructured bibliographic references, being the books under review (`sb:reference` and `ce:other-ref`), the author groups (`ce:author-group`), the article history (`ce:date-received`, `ce:date-revised`, `ce:date-accepted`) and `ce:miscellaneous`.

The `book-review-head` differs from a `head` in that `head`’s subtitles have been replaced by information about the book or books under review. Moreover, `ce:title` is not mandatory; instead, there must be at least a `ce:dochead` or a `ce:title`. There is no dedication or presented by, and there are no keywords and (stereochemistry) abstracts.

An example of an opening of a book review is shown in Figs. 2 and 3.



Science of Computer Programming 31 (1998) 383–385

---



---

Science of  
Computer  
Programming

---



---

## Book review\*

**V. Stoltenberg-Hansen, I. Lindström and E.R. Griffor, *Mathematical Theory of Domains* (Cambridge Tracts in Theoretical Computer Science 22, 1994) 349 pp., Hardback.**

Domain theory is the study of certain kinds of mathematical structure, *domains*, which model notions of approximation in computation. Such structures first arose in the development of denotational semantics of programming languages, where the notion of approximation was crucial for modelling recursion and recursively defined datatypes. From these roots, domain theory has blossomed into an interesting mathematical theory in its own right. Many varieties of domains have been identified and classified, with applications ranging from computation in continuous mathematics to abstract recursion theory.

Other recent textbooks in the area have been primarily concerned with the denotational semantics of programming languages, introducing domain theory as a necessary tool for the provision of such. *Mathematical Theory of Domains* takes an alternative approach, presenting domain theory very much from a pure mathematical standpoint. This approach is to be applauded. The mathematical theory of domains is more than sufficiently rich to deserve such a presentation, and previous expositions from this viewpoint have appeared only as unpublished notes, or as chapters in handbooks. Therefore, the authors have identified a genuine gap in the market. The question is how well they have filled it.

[...]

In summary, this book tackles the worthy goal of presenting domain theory as an interesting mathematical theory in its own right. Although the presentation is not completely to my taste, the book is well written and does contain a wealth of valuable material, especially in its second half. I would not entirely endorse it as an introductory textbook, but it is highly recommended as a useful and informative addition to any researcher's bookshelf.

Alex Simpson  
University of Edinburgh

---

\*Review copies of books which might be of interest to the readers of *Science of Computer Programming* should be sent to Prof. K. Apt (address: see inside front cover). Proceedings of conferences will not normally be reviewed.

Figure 2: Example of an article opening (a mocked-up example from which some text has been removed). Its XML coding can be found in Fig. 3.

## Version history

Subelement [ce:markers](#) was introduced in JA DTD 5.0.2. Subelement [ce:label](#) was introduced in JA DTD 5.1.0.

## Light reading

The complete head is part of HEAD-ONLY and HEAD-AND-TAIL files. A CONTENTS-ENTRY-ONLY file can only contain [ce:article-footnote](#), [ce:title](#) and [ce:subtitle](#), and within [ce:author-group](#) only [ce:author](#) and [ce:collaboration](#).

## See also

[head](#), [simple-head](#)

---

```

<?xml version="1.0" encoding="UTF-8" ?>
<!DOCTYPE book-review
  PUBLIC "-//ES//DTD full length article DTD version 5.0.1//EN//XML"
  "art501.dtd">
<book-review docsubtype="brv">
<item-info>
  <jid>SCIC0</jid><aid>508</aid>
  <ce:pII>S0167-6423(98)00009-4</ce:pII>
  <ce:doi>10.1016/S0167-6423(98)00009-4</ce:doi>
  <ce:copyright type="unknown" yr="1998"></ce:copyright>
</item-info>
<book-review-head>
  <ce:article-footnote>
    <ce:label>*</ce:label>
    <ce:note-para>Review copies of books which might be of interest
      to the readers of ...</ce:note-para>
  </ce:article-footnote>
  <ce:dochead><ce:textfn>Book review</ce:textfn></ce:dochead>
  <sb:reference>
    <sb:contribution>
      <sb:authors>
        <sb:author>
          <ce:given-name>V.</ce:given-name><ce:surname>Stoltenberg-Hansen</ce:surname>
        </sb:author>
        <sb:author>
          <ce:given-name>I.</ce:given-name><ce:surname>Lindström</ce:surname>
        </sb:author>
        <sb:author>
          <ce:given-name>E.R.</ce:given-name><ce:surname>Griffor</ce:surname>
        </sb:author>
      </sb:authors>
      <sb:title><sb:maintitle>Mathematical Theory of Domains</sb:maintitle></sb:title>
    </sb:contribution>
    <sb:host>
      <sb:book>
        <sb:book-series>
          <sb:series>
            <sb:title>
              <ce:maintitle>Cambridge Tracts in Theoretical Computer
                Science</ce:maintitle>
            </sb:title>
            <sb:volume-nr>22</sb:volume-nr>
          </sb:series>
        </sb:book-series>
        <sb:date>1994</sb:date>
      </sb:book>
    </sb:host>
    <sb:comment>349 pp., Hardback.</sb:comment>
  </sb:reference>
  <ce:author-group>
    <ce:author>
      <ce:given-name>Alex</ce:given-name><ce:surname>Simpson</ce:surname>
    </ce:author>
    <ce:affiliation>
      <ce:textfn>University of Edinburgh</ce:textfn>
    </ce:affiliation>
  </ce:author-group>
</book-review-head>
<body>
  <ce:sections>
    <ce:para>Domain theory is the study of certain kinds of mathematical
      structure, <ce:italic>domains</ce:italic>, which model notions
      of approximation in computation. ...
  </ce:para>
  </ce:sections>

```

---

Figure 3: XML of the article opening shown in Fig. 2.

## exam

### Declaration

#### Model (JA DTD 5.0.1, JA DTD 5.0.2)

```
<!ELEMENT exam ( item-info, ce:floats?, simple-
                head, ( ce:exam-answers | ce:exam-
                questions )+ )>
<!ATTLIST exam
  xmlns          CDATA          #FIXED %ESJA.xmlns;
  version        CDATA          #FIXED '5.0'
  xmlns:ce       CDATA          #FIXED %ESCE.xmlns;
  xmlns:sb       CDATA          #FIXED %ESSB.xmlns;
  xmlns:xlink    CDATA          #FIXED %XLINK.xmlns;
  xml:lang       %language;     'en'
  docsubtype     %docsubtype;   #FIXED "exm">
```

#### Model (JA DTD 5.1.0)

```
<!ELEMENT exam ( item-info, ce:floats?, simple-
                head, ( ce:exam-answers | ce:exam-
                questions )+ )>
<!ATTLIST exam
  xmlns          CDATA          #FIXED %ESJA.xmlns;
  version        CDATA          #FIXED '5.1'
  xmlns:ce       CDATA          #FIXED %ESCE.xmlns;
  xmlns:sb       CDATA          #FIXED %ESSB.xmlns;
  xmlns:xlink    CDATA          #FIXED %XLINK.xmlns;
  xml:lang       %iso639;      'en'
  docsubtype     ( exm|err )   "exm">
```

### Description

The element [exam](#) is used to structure an examination article.

### Usage

The element [exam](#) is one of the top-level elements (doctypes) of the JA DTD. It is used for structuring examinations. Examinations, e.g. for continuous medical education (CME), contain questions and answers. They can occur in the [tail](#) of an [article](#) but also have an independent existence.

There are several attributes of the element, as follows.

- The mandatory attribute [docsubtype](#) contains the [publication item type](#) (p. 56). The values `exm` and `err` are allowed.
- The attribute [xml:lang](#) specifies the language in which the article is written (default English, `en`). See Section 7.5 (p. 162) for an overview of the allowed language codes.
- The fixed attribute [xmlns](#) sets the default namespace for JA elements, and the other fixed attributes beginning with `xmlns:` set the prefix and the namespace of elements used in the DTD, e.g. those of the common element pool ([xmlns:ce](#) and [xmlns:sb](#)) and of the XLink standard ([xmlns:xlink](#)). Since these attributes are fixed, they need not be specified as they are inferred by the parser.
- [version](#) is fixed to the first two digits of the version of the DTD.

## Version history

In JA DTDs 5.0.1 and 5.0.2, [xml:lang](#) could only adopt the values English (en, default) French (fr), German (de), Portuguese (pt), Russian (ru), Spanish (es).

As of JA DTD 5.1.0, the value `err` is allowed for [docsubtype](#).

## See also

[article](#), [book-review](#), [simple-article](#), [ce:exam-questions](#)

# head

## Declaration

### Model (JA DTD 5.0.1)

```
<!ELEMENT head ( ce:article-footnote*, ce:dochead?,
ce:title, ce:subtitle?, ( ce:alt-
title, ce:alt-subtitle? )*,
ce:presented?, ce:dedication?,
ce:author-group+, ce:date-received?,
ce:date-revised*, ce:date-accepted?,
ce:miscellaneous?, ce:abstract*,
ce:keywords*, ce:stereochem* )>
```

### Model (JA DTD 5.0.2)

```
<!ELEMENT head ( ce:article-footnote*, ce:markers?,
ce:dochead?, ce:title, ce:subtitle?,
( ce:alt-title, ce:alt-subtitle? )*,
ce:presented?, ce:dedication?,
ce:author-group+, ce:date-received?,
ce:date-revised*, ce:date-accepted?,
ce:miscellaneous?, ce:abstract*,
ce:keywords*, ce:stereochem* )>
```

### Model (JA DTD 5.1.0)

```
<!ELEMENT head ( ce:article-footnote*, ce:markers?,
ce:dochead?, ce:label?, ce:title,
ce:subtitle?, ( ce:alt-title,
ce:alt-subtitle? )*, ce:presented?,
ce:dedication?, ce:author-group+,
ce:date-received?, ce:date-
revised*, ce:date-accepted?,
ce:miscellaneous?, ce:abstract*,
ce:keywords*, ce:stereochem* )>
```

## Description

The element [head](#) contains the head or frontmatter of an article.

## Usage

The head of an article consists of the article footnotes ([ce:article-footnote](#)), markers ([ce:markers](#)), the document heading ([ce:dochead](#)), a label (e.g., “Chapter 7”) ([ce:label](#)), the article title and subtitle ([ce:title](#) and [ce:subtitle](#)), a sequence of titles and subtitles in an alternative language ([ce:alt-title](#) and [ce:alt-subtitle](#)), presented-by and dedicated-to information ([ce:presented](#) and [ce:dedication](#)), the author groups ([ce:author-group](#)), article history ([ce:date-received](#), [ce:date-revised](#), [ce:date-accepted](#) and [ce:miscellaneous](#)) abstracts of various classes, each in several possible languages ([ce:abstract](#)), keywords and classification codes ([ce:keywords](#)), stereochemistry abstracts ([ce:stereochem](#)).

An example of an article opening is shown in Figs. 4 and 5.

The [head](#) differs from a [simple-head](#) in that the title ([ce:title](#)) and the author group ([ce:author-group](#)) are mandatory.



## Version history

Subelement [ce:markers](#) was introduced in JA DTD 5.0.2. Subelement [ce:label](#) was introduced in JA DTD 5.1.0.

## Light reading

The complete head is part of HEAD-ONLY and HEAD-AND-TAIL files. A CONTENTS-ENTRY-ONLY file can only contain [ce:article-footnote](#), [ce:title](#) and [ce:subtitle](#), and within [ce:author-group](#) only [ce:author](#) and [ce:collaboration](#).

## See also

[book-review-head](#), [simple-head](#)



Sensors and Actuators 83 (2000) 156–160

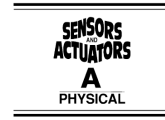

www.elsevier.nl/locate/sna

## Electroforming of 3D microstructures on highly structured surfaces<sup>☆</sup>

L.S. Johansen<sup>a,\*</sup>, M. Ginnerup<sup>a</sup>, P.T. Tang<sup>b</sup>, B. Löchel<sup>c,1</sup>

<sup>a</sup> Microelectronics Centre, Technical University of Denmark, Bldg. 345 East, DK-2800 Lyngby, Denmark

<sup>b</sup> Department of Manufacturing Engineering, Technical University of Denmark, Bldg. 204, DK-2800 Lyngby, Denmark

<sup>c</sup> Fraunhofer-Institut für Siliziumtechnologie, Dillenburger Straße 53, D-14199 Berlin, Germany

Received 7 June 1999; received in revised form 8 December 1999; accepted 21 December 1999

### Abstract

Electrodeposition of photoresist on highly structured surfaces is combined with electroplating to fabricate three new types of advanced 3D metal microstructures. In one application, electroplated nickel cantilever arrays are formed on the sloped sidewalls of KOH etched silicon. The cantilevers are released by sacrificial etching of copper. In another application it is shown how KOH etched silicon V-grooves can be patterned by electrodeposited photoresist to generate versatile 3D electroforming moulds. To demonstrate the potential of this technology, an innovative all-nickel cantilever structure with V-shaped cross section and integrated reflection mirror for optical readout has been fabricated. Cantilevers with V-cross section can be designed to have significantly larger out of plane bending stiffness or higher resonant frequency compared to rectangular cantilevers with similar dimensions. A third application uses electrodeposited photoresist to fabricate copper solenoids on an oxidised silicon support. © 2000 Elsevier Science S.A. All rights reserved.

**Keywords:** Electroplating; Electrodeposited photoresist; 3D fabrication; Cantilevers; Microcoils

### 1. Introduction

Conventional photoresist spin coating is an inherently planar technology and does not allow for conformal coating of highly structured surfaces. The advent of electrodeposited (ED) photoresists has made such conformal coatings possible. Due to the self-stopping deposition chemistry, ED resist can coat very uneven surfaces with a uniform layer thickness. The as-deposited resist film has a low water content and therefore only a small tendency to flow. Exposure can be carried out using standard UV mask aligners. Recently, X-ray exposure has also been employed, yielding very high pattern resolution at large mask gaps [1].

The above mentioned advantages of conformal coating have already resulted in a number of MEMS applications such as wafer feed-through leads [2,3], acoustic hole formation on the bottom of a KOH etched back plate for a condenser microphone [4], and patterning of 45° angled silicon mirrors [5]. The major drawback of ED resist is that only conducting surfaces can be coated. This might render it useless for applications where a conductive layer can not be applied. In electroplating processes however, a conductive seed layer is already present, and ED resist can easily be adapted as a plating mould. Since both electrodeposition and electroplating processes have the ability of covering complex topographies, a combination of these has great potential and has not yet been fully explored.

This paper presents three different demonstrations of how electrodeposition of photoresist on highly structured surfaces can be combined with electroplating to form new advanced metallic 3D structures. Hitherto, no releasing of microstructures defined by ED resist has been performed. Two of the demonstrators therefore show how novel released nickel cantilevers can be electroformed using ED photoresist moulds on non-planar surfaces, thus adding a new degree of freedom to microsystem design. The third application demonstrates an alternative fabrication of micro-solenoids, made possible by ED moulds. All three

<sup>☆</sup> This manuscript is based on a presentation (No. 2A2.4) delivered at the 10th International Conference on Solid-State Sensors and Actuators (Transducers '99). The title of the presentation was "Improved Piezo-Resistive Sensor using Novel Nickel-Induced Laterally Crystallized Polycrystalline Silicon."

\* Corresponding author. Tel.: +45-45-25-57-66/00; fax: +45-45-88-77-62.

E-mail address: lsj@mic.dtu.dk (L.S. Johansen).

<sup>1</sup> B. Löchel is now with BESSY, Anwenderzentrum Mikrotechnik, Albert Einstein Straße 15, D-12489 Berlin, Germany.

Figure 4: Example of an article opening. Its XML coding can be found in Fig. 5.

---

```

<?xml version="1.0" encoding="UTF-8" ?>
<!DOCTYPE article
  PUBLIC "-//ES//DTD full length article DTD version 5.0.1//EN//XML" "art501.dtd" [
<!ENTITY loc1 SYSTEM "gr1" NDATA IMAGE>]
<article docsubtype="fla">
<item-info>
  <jid>SNA</jid><aid>123</aid><ce:pai>S0924-4247(00)00346-0</ce:pai>
  <ce:doi>10.1016/S0924-4247(00)00346-0</ce:doi>
  <ce:copyright type="full-transfer" yr="2000">Elsevier Science S.A.</ce:copyright>
</item-info>
<head>
  <ce:article-footnote><ce:label>&z.star;</ce:label>
  <ce:note-para>This manuscript is based on a presentation (No. 2A2.4)
    delivered at the 10th International Conference ...</ce:note-para>
</ce:article-footnote>
<ce:title>Electroforming of 3D microstructures on highly structured surfaces</ce:title>
<ce:author-group>
  <ce:author>
    <ce:given-name>L.S.</ce:given-name><ce:surname>Johansen</ce:surname>
    <ce:cross-ref refid="aff1"><ce:sup>a</ce:sup></ce:cross-ref>
    <ce:cross-ref refid="cor1"><ce:sup>&#x0204E;</ce:sup></ce:cross-ref>
    <ce:e-address type="email">lsj@mic.dtu.dk</ce:e-address>
  </ce:author>
  <ce:author>
    <ce:given-name>M.</ce:given-name><ce:surname>Ginnerup</ce:surname>
    <ce:cross-ref refid="aff1"><ce:sup>a</ce:sup></ce:cross-ref>
  </ce:author>
  <ce:author>
    <ce:given-name>P.T.</ce:given-name><ce:surname>Tang</ce:surname>
    <ce:cross-ref refid="aff2"><ce:sup>b</ce:sup></ce:cross-ref>
  </ce:author>
  <ce:author>
    <ce:given-name>N.</ce:given-name><ce:surname>Löchel</ce:surname>
    <ce:cross-ref refid="aff3"><ce:sup>c</ce:sup></ce:cross-ref>
    <ce:cross-ref refid="fn1"><ce:sup>1</ce:sup></ce:cross-ref>
  </ce:author>
  <ce:affiliation id="aff1"><ce:label>a</ce:label>
    <ce:textfn>Microelectronics Centre, Technical University
      of Denmark, Bldg. 345 East, DK-2800 Lyngby, Denmark</ce:textfn>
  </ce:affiliation>
  <ce:affiliation id="aff2"><ce:label>b</ce:label>
    <ce:textfn>Department of Manufacturing Engineering,
      Technical University of Denmark, Bldg. 204, DK-2800 Lyngby, Denmark</ce:textfn>
  </ce:affiliation>
  <ce:affiliation id="aff3"><ce:label>c</ce:label>
    <ce:textfn>Fraunhofer-Institut für Siliziumtechnologie, Dillenburg
      Straße 53, D-14199 Berlin, Germany</ce:textfn>
  </ce:affiliation>
  <ce:correspondence id="cor1"><ce:label>&#x0204E;</ce:label>
    <ce:text>Corresponding author. Tel.: +45-45-25-57-66/00; fax: +45-45-88-77-62.</ce:text>
  </ce:correspondence>
  <ce:footnote id="fn1"><ce:label>1</ce:label>
    <ce:note-para>B. Löchel is now with BESSY, Anwenderzentrum Mikrotechnik,
      Albert Einstein Straße 15, D-12489 Berlin, Germany.</ce:note-para>
  </ce:footnote>
</ce:author-group>
<ce:date-received day="7" month="6" year="1999"/>
<ce:date-revised day="8" month="12" year="1999"/>
<ce:date-accepted day="21" month="12" year="1999"/>
<ce:abstract>
  <ce:section-title>Abstract</ce:section-title>
  <ce:abstract-sec><ce:simple-para>Electrodeposition of photoresist on
    highly ... oxidised silicon support.</ce:simple-para></ce:abstract-sec>
</ce:abstract>
<ce:keywords>
  <ce:keyword>Electroplating</ce:keyword><ce:keyword>Electrodeposited photoresist</ce:keyword>
  <ce:keyword>3D fabrication</ce:keyword><ce:keyword>Cantilevers</ce:keyword>
  <ce:keyword>Microcoils</ce:keyword>
</ce:keywords>
</head>
<body>
  <ce:sections>
    <ce:section><ce:label>1</ce:label><ce:section-title>Introduction</ce:section-title>
    <ce:para>Conventional photoresist spin coating is an ...

```

---

Figure 5: XML of the article opening shown in Fig. 4.

## item-info

### Declaration

#### Model (JA DTD 5.0.1–JA DTD 5.1.0)

```
<!ELEMENT item-info          ( jid, aid?, ce:pii, ce:doi?,
                               ce:document-thread?, ce:copyright,
                               ce:doctopics?, ce:preprint? )>
```

### Description

The element `item-info` contains information about the article.

### Usage

Item information is contained within `item-info`. The Elsevier system code and article number are present in `jid` and `aid`. This is followed by the PII and optionally the DOI, `ce:pii` and `ce:doi`. The DOI is not always present, since it may be assigned only to items that will be published online.

A relationship with other articles can be made using `ce:document-thread`, e.g. to link an erratum to the original article or to create a discussion thread.

The mandatory `ce:copyright` contains the copyright owner and status of the item.

The `ce:doctopics` can be used to place the article in a topic hierarchy.

Finally, the subelement `ce:preprint` is to link the item with a preprint of the article residing on a preprint server.

For more information, see the subelements.

#### XML

```
<item-info>
  <jid>AQTOX</jid>
  <aid>1099</aid>
  <ce:pii>S0166-445X(99)00065-X</ce:pii>
  <ce:doi>10.1016/S0166-445X(99)00065-X</ce:doi>
  <ce:copyright type="full-transfer" year="2000">Elsevier
    Science B.V.</ce:copyright>
</item-info>
```

# **jid**

## **Declaration**

### **Model (JA DTD 5.0.1–JA DTD 5.1.0)**

```
<!ELEMENT jid ( %string.data; )*>
```

## **Description**

The element `jid` contains the Elsevier system code of the journal.

## **See also**

[aid](#), [ce:pii](#), [ce:doi](#)

## simple-article

### Declaration

#### Model (JA DTD 5.0.1, JA DTD 5.0.2)

```
<!ELEMENT simple-article      ( item-info, ce:floats?, simple-head,
                               body?, simple-tail? )>
<!ATTLIST simple-article
  xmlns          CDATA          #FIXED %ESJA.xmlns;
  version        CDATA          #FIXED '5.0'
  xmlns:ce       CDATA          #FIXED %ESCE.xmlns;
  xmlns:sb       CDATA          #FIXED %ESSB.xmlns;
  xmlns:xlink    CDATA          #FIXED %XLINK.xmlns;
  xml:lang       %language;     'en'
  docsubtyp     %docsubtype;    #REQUIRED>
```

#### Model (JA DTD 5.1.0)

```
<!ELEMENT simple-article      ( item-info, ce:floats?, simple-head,
                               body?, simple-tail? )>
<!ATTLIST simple-article
  xmlns          CDATA          #FIXED %ESJA.xmlns;
  version        CDATA          #FIXED '5.1'
  xmlns:ce       CDATA          #FIXED %ESCE.xmlns;
  xmlns:sb       CDATA          #FIXED %ESSB.xmlns;
  xmlns:xlink    CDATA          #FIXED %XLINK.xmlns;
  xml:lang       %iso639;      'en'
  docsubtyp     %docsubtype;    #REQUIRED>
```

### Description

The element [simple-article](#) is used to structure a simple article.

### Usage

The element [simple-article](#) is one of the top-level elements (doctypes) of the JA DTD. It is used for structuring “simple” articles, such as editorials, obituaries, prefaces, etc. Ironically, simple articles are more complicated in an XML sense, since enforcing strict rules is not always possible due to the great variety of appearances of these articles.

Note that even a full-length article might be structured as a simple article, e.g. when it is delivered as CONTENTS-ENTRY-ONLY.

There are several attributes of the element, as follows.

- The attribute [docsubtype](#) is the most important one. It is mandatory; its complete list of values is described in the section [Publication item types](#) (p. 56).
- The attribute [xml:lang](#) specifies the language in which the article is written (default English, en). See Section 7.5 (p. 162) for an overview of the allowed language codes.
- The fixed attribute [xmlns](#) sets the default namespace for JA elements, and the other fixed attributes beginning with [xmlns:](#) set the prefix and the namespace of elements used in the DTD, e.g. those of the common element pool ([xmlns:ce](#) and [xmlns:sb](#)) and of the XLink standard ([xmlns:xlink](#)). Since these attributes are fixed, they need not be specified as they are inferred by the parser.
- [version](#) is fixed to the first two digits of the version of the DTD.

## Version history

In JA DTDs 5.0.1 and 5.0.2, [xml:lang](#) could only adopt the values English (en, default) French (fr), German (de), Portuguese (pt), Russian (ru), Spanish (es).

## See also

[article](#), [book-review](#), [exam](#)

## simple-head

### Declaration

#### Model (JA DTD 5.0.1)

```
<!ELEMENT simple-head
( ce:article-footnote*, ( ce:title
| ( ce:dochead, ce:title? ) ),
ce:subtitle?, ( ce:alt-title, ce:alt-
subtitle? )*, ce:author-group*,
ce:date-received?, ce:date-revised*,
ce:date-accepted?, ce:miscellaneous?,
ce:abstract*, ce:keywords* )>
```

#### Model (JA DTD 5.0.2)

```
<!ELEMENT simple-head
( ce:article-footnote*, ce:markers?,
( ce:title | ( ce:dochead,
ce:title? ) ), ce:subtitle?,
( ce:alt-title, ce:alt-subtitle? )*,
ce:author-group*, ce:date-received?,
ce:date-revised*, ce:date-accepted?,
ce:miscellaneous?, ce:abstract*,
ce:keywords* )>
```

#### Model (JA DTD 5.1.0)

```
<!ELEMENT simple-head
( ce:article-footnote*, ce:markers?,
( ( ce:label?, ce:title ) |
( ce:dochead, ce:label?, ce:title? ) ),
ce:subtitle?, ( ce:alt-title, ce:alt-
subtitle? )*, ce:author-group*,
ce:date-received?, ce:date-revised*,
ce:date-accepted?, ce:miscellaneous?,
ce:abstract*, ce:keywords* )>
```

### Description

The element [simple-head](#) contains the head or frontmatter of a “simple” article or an examination item, [simple-article](#) or [exam](#).

### Usage

The head of a simple article consists of the article footnotes ([ce:article-footnote](#)), markers ([ce:markers](#)), the document heading ([ce:dochead](#)), a label (e.g., “Chapter 7”) ([ce:label](#)), the article title and subtitle ([ce:title](#), [ce:subtitle](#)), a sequence of titles and subtitles in an alternative language ([ce:alt-title](#) and [ce:alt-subtitle](#)), the author groups ([ce:author-group](#)), article history ([ce:date-received](#), [ce:date-revised](#), [ce:date-accepted](#) and [ce:miscellaneous](#)) abstracts of various classes, each in several possible languages ([ce:abstract](#)), keywords and classification codes ([ce:keywords](#)).

The [simple-head](#) differs from a [head](#) in that the title ([ce:title](#)) is mandatory in a head, whereas in a simple head there is at least a [ce:dochead](#) or a title; the author group ([ce:author-group](#)) is mandatory in a head; and in a simple head there is no presented by or dedicated to information and there are no stereochemistry abstracts.



## Version history

Subelement [ce:markers](#) was introduced in JA DTD 5.0.2. Subelement [ce:label](#) was introduced in JA DTD 5.1.0.

## Light reading

The complete head is part of HEAD-ONLY and HEAD-AND-TAIL files. A CONTENTS-ENTRY-ONLY file can only contain [ce:article-footnote](#), [ce:title](#) and [ce:subtitle](#), and within [ce:author-group](#) only [ce:author](#) and [ce:collaboration](#).

## See also

[book-review-head](#), [head](#)

## simple-tail

### Declaration

#### Model (JA DTD 5.0.1, JA DTD 5.0.2)

```
<!ELEMENT simple-tail      ( ce:bibliography?, ce:further-
                             reading? )>
<!ATTLIST simple-tail
    view          %view;          'all'>
```

#### Model (JA DTD 5.1.0)

```
<!ELEMENT simple-tail      ( ce:bibliography?, ce:further-reading?,
                             ce:glossary?, ce:biography* )>
<!ATTLIST simple-tail
    view          %view;          'all'>
```

### Description

The element [simple-tail](#) contains the tail of a simple article or book review.

### Usage

The tail of a simple article or a book review is contained within [simple-tail](#). This element consists of four subelements: an optional [ce:bibliography](#) (containing the bibliographic references) and an optional [ce:further-reading](#) (containing the further-reading list), a glossary ([ce:glossary](#)) and a number of biographies of the authors ([ce:biography](#)).

### Version history

The subelements [ce:glossary](#) and [ce:biography](#) were added in JA DTD 5.1.0.

### See also

[tail](#)

# tail

## Declaration

### Model (JA DTD 5.0.1–JA DTD 5.1.0)

```
<!ELEMENT tail
( ce:bibliography?, ce:further-
  reading?, ce:glossary?, ce:biography*,
  ( ce:exam-answers | ce:exam-questions
  | ce:exam-reference )* )>
<!ATTLIST tail
  view %view; 'all'>
```

## Description

The element [tail](#) contains the tail of an article.

## Usage

The tail of an article or a book review is contained within [tail](#). None of its constituents are mandatory, but the element must not be empty.

The tail consists of the bibliographic references ([ce:bibliography](#)), a further-reading list ([ce:further-reading](#)), a glossary ([ce:glossary](#)), a number of biographies of the authors ([ce:biography](#)), followed by a sequence of examination questions and answers, and references to earlier examinations ([ce:exam-questions](#), [ce:exam-answers](#), [ce:exam-reference](#)). For more information, see these elements.

## See also

[simple-tail](#)

## PITs: Journal article publication item types

The attribute `docsubtype` of the top-level elements of the journal article DTD contains the publication item type of the article. Its possible values are contained in `%docsubtype`; and are described here.

PIT	Short	Description
<code>abs</code>	Abstract	Abstract of a paper or oral presentation or poster, published as a separate item. A better name would be “very short communication”. These mostly occur in fairly great numbers in conference proceedings, where not all authors are allowed to publish a full-length article. <i>Note.</i> Not to be confused with <code>lit</code> ( <i>q.v.</i> ). <i>Note.</i> <code>abs</code> refers to one single such thing.
<code>add</code>	Addendum	Publication item giving additional information regarding another publication item, mostly presenting additional results. <i>Note.</i> Needs a <code>ce:document-thread</code> .
<code>adv</code>	Advertisement	Advertisement (mostly commercial, but also including Elsevier’s own).
<code>ann</code>	Announcement	Informative statement with a scope within the context of the publication in which it appears.
<code>brv</code>	Book review	Book review. <i>Note.</i> <code>brv</code> can only be assigned to a single book review, not to a collection of book reviews which appear under the heading “Book reviews”.
<code>cal</code>	Calendar	List of forthcoming meetings, symposia, conferences and other events.
<code>chp</code>	Chapter	Complete chapter in a book series volume. Similar to <code>fla</code> .
<code>cnf</code>	Conference	Information about a conference (can be a description of the venue, but also a visit report of a scientist who has attended a conference). <i>Note.</i> A scientific article in a conference proceedings is not <code>cnf</code> .
<code>con</code>	Contents list	List of publication items published in issue(s) or volume(s) of the publication at hand. <i>Note.</i> This includes volume contents. This PIT is only rarely used, in case a list of contents requires an XML delivery and is handled as a contents entry.
<code>cor</code>	Correspondence	Letter to the editor or a reply to the letter. <i>Note.</i> The reply needs a <code>ce:document-thread</code> .
<code>cop</code>	Copyright	Item detailing the copyright of the work, containing the information traditionally found on the copyright page in the frontmatter.
<code>dis</code>	Discussion	Argumentative communication, like papers in a discussion, but also perspectives, commentaries, etc. <i>Note.</i> Subsequent discussion papers need a <code>ce:document-thread</code> .
<code>dup</code>	Duplicate	Tombstone article, duplicate of a published article. See ref. [25].

PIT	Short	Description
edb	Editorial board	List containing the scientific editors, the managing and executive editors, etc., of the publication.
edi	Editorial	From the (guest-) editor of the publication. Can be Foreword, Editorial, Guest-Editorial, Preface, etc.
err	Erratum	Article in which errors are reported that were made in an earlier publication in the same journal. Can be Erratum but also Corrigendum. <i>Note.</i> Needs a <a href="#">ce:document-thread</a> .
exm	Examination	Examination or quiz, with questions and answers.
fla	Full-length article	Complete report on original research.
ind	Index	Cross-reference of items against the location of occurrence. Can be Author index, Master index, Subject index, Materials index, etc.
lit	Literature alert	Publication item containing information on relevant literature. This includes lists of recently published books, and collections of abstracts of articles published, or to be published, elsewhere (in the same or another journal). <i>Note.</i> Such abstracts should not be confused with articles of type <a href="#">abs</a> . Those are independent, small articles. These are sequences of abstracts of other articles whose bibliographic source is mentioned.
mis	Miscellaneous	All publication items that do not fit in any of the other publication item types mentioned and that do not merit the introduction of a new type.
nws	News	Publication item containing new information relevant to the audience of the publication.
ocn	Other contents	Contents list of another, related journal. <i>Note.</i> Must be another journal.
pgl	Practice guideline	A report that describes guidelines for effective diagnosis or treatment of a medical condition. The report is generally authored by a society, government agency, or working group.
pnt	Patent report	Report on newly developed patents.
prp	Personal report	Bit of a misnomer: it is in fact a report about one or more (living or deceased) persons, e.g. an obituary, a biography, an award ceremony, etc., but it can also include personal historical overviews or reminiscences of the author.
prv	Product review	Product review, i.e. a review of software, hardware, medical products, etc. <i>Note.</i> Not book reviews: see <a href="#">brv</a> . Not conference review: see <a href="#">cnf</a> .
pub	Publisher's note	Publisher's note, which is a message from the Publisher to the readers.
rem	Removal	Tombstone article, removed. The article has been retracted and its original text is completely removed from public access. See ref. [26].
req	Request for assistance	Publication item containing the description of a problem with an appeal to the audience for a solution.

PIT	Short	Description
ret	Retraction	Tombstone article, retracted. See ref. [26].
rev	Review article	Substantial overview of original research, usually with a comprehensive bibliography, often with a table of contents. <i>Note.</i> Not a book review: see <a href="#">brv</a> .
sco	Short communication	Short report or announcement of research, usually claiming certain results, usually with a shorter publication time than other papers in the same publication. Appear under many names, such as letter papers, preliminary notes, notes, etc.
ssu	Short survey	Short or mini-review, in appearance much like a short full-length article.

## Chapter 4

# Serial Issue DTD

This chapter contains an alphabetic listing of the elements in the serial issue DTD, SI DTD. This DTD is used for defining journal issues and book series volumes, i.e. it captures the exact composition of the issue in the form of pointers to the individual items, and it captures the issue's properties such as title, (guest) editors, cover date, etc. A document structured with the SI DTD is often called an *issue hub*.

The serial issue DTD defines one top-level element: [serial-issue](#).

### **CEP version used in this DTD**

The serial issue DTD 5.1.0 described in this documentation uses the common element pool version 1.1.3.

## abbr-name

### Declaration

#### Model

```
<!ELEMENT abbr-name ( %richstring.data; )*>
```

### Description

The element [abbr-name](#) contains the official abbreviated name of a conference.

### Usage

See [conference-info](#).



# conference-info

## Declaration

### Model

```
<!ELEMENT conference-info      ( full-name?, abbr-name?, venue?,
                                date-range? )>
```

## Description

The element `conference-info` contains information about a conference.

## Usage

Issues can be related to a conference or contain the proceedings of a conference. In that case, information about the conference is captured with `conference-info`.

The `full-name` contains the full name of the conference if it is different from the title of the issue. Often, a conference also has an commonly known abbreviated name, `abbr-name`. The location where the conference took place is captured with `venue`. A subelement `date-range` is provided for the date or date range when the conference took place. The four subelements are optional, but `conference-info` must not be empty.

*XML*

```
<conference-info>
  <full-name>Foundations of Software Science
    and Computation Structures</full-name>
  <abbr-name>FOSSACS 2001</abbr-name>
  <venue>Genova, Italy</venue>
  <date-range>
    <start-date>20010402</start-date>
    <end-date>20010404</end-date>
  </date-range>
</conference-info>
```

*XML*

```
<conference-info>
  <full-name>Periglacial Geomorphology at
    the Beginning of the 21st Century</full-name>
  <venue>Tokyo, Japan</venue>
  <date-range>
    <start-date>20010825</start-date>
  </date-range>
</conference-info>
```

## See also

[date-range](#)

## cover-date

### Declaration

#### Model

```
<!ELEMENT cover-date ( date-range )>
```

### Description

The element `cover-date` contains the cover date of the issue.

### Usage

The cover date of the issue is contained within `cover-date` in the form of a `date-range`.

It is not always clear for each publication what the cover date is. Some serial publications do not carry a cover date on the cover of their printed issues. ScienceDirect<sup>®</sup>, however, displays the cover date prominently with each issue in the issue list for each journal or book series, and uses it to determine the publication year when it generates the bibliographic data for the items in the issue. For lack of a more precise definition, the date displayed there is the cover date contained in this element.

## cover-image

### Declaration

#### Model

```
<!ELEMENT cover-image ( ce:figure )>
```

### Description

The element `cover-image` contains the cover image of a serial issue.

### Usage

Cover images are captured with the element `cover-image`.

Structurally, the cover image is associated with the issue using the `ce:figure`, which in this case may not be nested within itself. The `ce:link` element provides the link to the cover image file. An optional caption explaining the featured cover image, copyright information, etc., can be added, using the features of `ce:figure`.

#### XML

```
<cover-image>
  <ce:figure>
    <ce:label>Functional Specificity of Small GTPases</ce:label>
    <ce:caption>
      <ce:simple-para>The cover shows eight of the distinct cell
        morphology classes that were induced by expression of
        constitutively active Ras superfamily small GTPases. NIH3T3
        fibroblasts were transfected with 100 different mutant small
        GTPases and the observed morphologies were grouped into
        different classes. The cell in the middle is a cell
        transfected with a control construct. For further
        information, please see the article by Heo and Meyer in
        this issue (pp. <ce:inter-ref xlink:href="doi:10.1016/
        S0092-8674(03)00307-6">369-381</ce:inter-ref>).
      </ce:simple-para>
    </ce:caption>
    <ce:link locator="cover"/>
  </ce:figure>
</cover-image>
```

#### Presentation

See Figure 6 (p. 79) for a possible representation.

### See also

[ce:figure](#)

## date-range

### Declaration

#### Model

```
<!ELEMENT date-range          ( start-date, end-date? )>
```

### Description

The element `date-range` contains the date range in EFFECT date format.

### Usage

The element `date-range` consists of a `start-date` and an optional `end-date`, both in EFFECT format.

The EFFECT date format has one of three EFFECT date *forms*.

- YYYY, denoting a year.
- YYYYMM, where YYYY is a year, and MM is a month, season or quarter. If MM ranges between 01 and 12, then it denotes a month (January to December). If MM ranges between 21 and 24, then it denotes a season (21: Spring, 22: Summer, 23: Autumn, 24: Winter). If MM ranges between 31 and 34, then it denotes a quarter (31: 1st Quarter, 32: 2nd Quarter, 33: 3rd Quarter, 34: 4th Quarter).
- YYYYMMDD, denoting a day.

The `end-date` must be of the same EFFECT date form as the `start-date`.

There is also an EFFECT date *range* format, containing a slash. This must not be used.

#### XML

```
<date-range><start-date>2003</start-date></date-range>
<date-range><start-date>200305</start-date></date-range>
<date-range><start-date>200331</start-date></date-range>
<date-range><start-date>20040229</start-date></date-range>
<date-range>
  <start-date>200305</start-date>
  <end-date>200307</end-date>
</date-range>
<date-range>
  <start-date>20030530</start-date>
  <end-date>20030601</end-date>
</date-range>
<date-range>
  <start-date>20030530</start-date>
  <end-date>20030531</end-date>
</date-range>
```

#### Presentation

```
2003
May 2003
First quarter 2003
29 February 2003
May – July 2003
30 May – 1 June 2003
30–31 May 2003
```

## editors

### Declaration

#### Model

```
<!ELEMENT editors ( %richstring.data; )*>
```

### Description

The element `editors` contains the names of the (guest) editors of a serial issue in an unstructured format.

### Usage

See [title-editors-group](#).

*XML*

```
<editors>P. Johnson and K.S. Agarwal</editors>
```

This element is provided for backward compatibility with the EFFECT dataset.toc dataset description file.

## end-date

### Declaration

#### Model

```
<!ELEMENT end-date ( %string.data; )*>
```

### Description

The element [end-date](#) contains the end date of a date range in EFFECT format.

### Usage

See [date-range](#).

## full-name

### Declaration

#### Model

```
<!ELEMENT full-name ( %richstring.data; )*>
```

### Description

The element [full-name](#) contains the full name of a conference if it is different from the issue title.

### Usage

See [conference-info](#).

## iss-first

### Declaration

#### Model

```
<!ELEMENT iss-first ( %string.data; )*>
```

### Description

The element `iss-first` contains the issue number, or the first issue number in an issue number range, of a serial issue.

### Usage

See [volume-issue-number](#).



## iss-last

### Declaration

#### Model

```
<!ELEMENT iss-last ( %string.data; )*>
```

### Description

The element `iss-last` contains the last issue number in an issue number range of a serial issue.

### Usage

See [volume-issue-number](#).

## issue-body

### Declaration

#### Model

```
<!ELEMENT issue-body          ( ( ce:include-item | issue-sec )+ )>
```

### Description

The element `issue-body` provides the link between the issue and the items in that issue. It is both a “hub” and the source for the table of contents.

### Usage

The issue body consist of all items that belong to the issue. These items are referred to via the generic `ce:include-item` element. Thus it acts as hub for the whole issue, but it also acts as the table of contents of the issue. The items can be grouped in sections, `issue-sec`, that must have a section title. These sections can be nested. In this way, second-, third- and fourth-order headings within the table of contents are supported. Headings of higher order than that, though possible according to the DTD, are not allowed. In files structured according to the SI DTD, the title subelements of `ce:include-item` are not used.

#### XML

```
<issue-body>
  <issue-sec>
    <ce:section-title>Nuclear Structure
      and Dynamics</ce:section-title>
    <ce:include-item>
      <ce:pri>S0375-9474(02)01400-8</ce:pri>
      <ce:doi>10.1016/S0375-9474(02)01400-8</ce:doi>
      <ce:pages>
        <ce:first-page>355</ce:first-page>
        <ce:last-page>390</ce:last-page>
      </ce:pages>
    </ce:include-item>
    ...
    <ce:include-item>
      <ce:pri>S0375-9474(02)01372-6</ce:pri>
      <ce:doi>10.1016/S0375-9474(02)01372-6</ce:doi>
      <ce:pages>
        <ce:first-page>463</ce:first-page>
        <ce:last-page>477</ce:last-page>
      </ce:pages>
    </ce:include-item>
  </issue-sec>
  <issue-sec>
    <ce:section-title>Hadronic Physics</ce:section-title>
    <ce:include-item>
      <ce:pri>S0375-9474(02)01371-4</ce:pri>
      <ce:doi>10.16/S0375-9474(02)01371-4</ce:doi>
      <ce:pages>
        <ce:first-page>481</ce:first-page>
```

```

        <ce:last-page>501</ce:last-page>
      </ce:pages>
    </ce:include-item>
    ...
    <ce:include-item>
      <ce:pii>S0375-9474(02)01403-3</ce:pii>
      <ce:doi>10.1016/S0375-9474(02)01403-3</ce:doi>
      <ce:pages>
        <ce:first-page>632</ce:first-page>
        <ce:last-page>640</ce:last-page>
      </ce:pages>
    </ce:include-item>
  </issue-sec>
<issue-sec>
  <ce:section-title>Intermediate and High Energy
    Heavy Ion Physics</ce:section-title>
  <ce:include-item>
    <ce:pii>S0375-9474(02)01399-4</ce:pii>
    <ce:doi>10.1016/S0375-9474(02)01399-4</ce:doi>
    <ce:pages>
      <ce:first-page>643</ce:first-page>
      <ce:last-page>670</ce:last-page>
    </ce:pages>
  </ce:include-item>
</issue-sec>
<issue-sec>
  <ce:section-title>Nuclear Astrophysics</ce:section-title>
  <ce:include-item>
    <ce:pii>S0375-9474(02)01397-0</ce:pii>
    <ce:doi>10.1016/S0375-9474(02)01397-0</ce:doi>
    <ce:pages>
      <ce:first-page>673</ce:first-page>
      <ce:last-page>695</ce:last-page>
    </ce:pages>
  </ce:include-item>
</issue-sec>
<issue-sec>
  <ce:section-title>Errata</ce:section-title>
  <ce:include-item>
    <ce:pii>S0375-9474(02)01363-5</ce:pii>
    <ce:doi>10.1016/S0375-9474(02)01363-5</ce:doi>
    <ce:pages>
      <ce:first-page>696</ce:first-page>
      <ce:last-page>698</ce:last-page>
    </ce:pages>
  </ce:include-item>
</issue-sec>
<ce:include-item>
  <ce:pii>S0375-9474(02)01580-4</ce:pii>
  <ce:doi>10.1016/S0375-9474(02)01580-4</ce:doi>
  <ce:pages>
    <ce:first-page>699</ce:first-page>
    <ce:last-page>727</ce:last-page>
  </ce:pages>

```

```
</ce:include-item>
</issue-body>
```

#### Presentation

##### Nuclear Structure and Dynamics

T. von Egidy, C. Doll, J. Jolie, N.V. Warr, J. Kern, M. Crittin and L. Genilloud  
*Nuclear structure of  $^{126}\text{Te}$  studied with the  $(n, \gamma)$  reaction* 355

⋮

M. Sambataro  
*RPA-like calculations within limited particle–hole spaces* 463

##### Hadronic Physics

F. Neumann, M. Buballa and M. Oertel  
*Mixed phases of color superconducting quark matter* 481

⋮

M.P. Rekalo and E. Tomasi-Gustafsson  
*Determination of the  $g_{V\sigma\gamma}$  coupling constant through the process  $\gamma + N \rightarrow N + V$  with circularly polarized photons* 632

##### Intermediate and High Energy Heavy Ion Physics

C. Fuchs and T. Gaitanos  
*Consequences of kinetic non-equilibrium for the nuclear equation-of-state in heavy ion collision* 643

##### Nuclear Astrophysics

E. Holmlund and J. Suhonen  
*Microscopic nuclear structure calculations for the solar-neutrino detector  $^{71}\text{Ga}$  and close-lying isobars* 673

##### Errata

H. Nakada and M. Sato  
*Erratum to: “A method of implementing Hartree–Fock calculations with zero- and finite-range interactions” [Nucl. Phys. A 699 (2002) 511]* 696

*Cumulative author index* 699

Add-on items, short commentaries that follow an item, are included with `ce:include-items`. The main item does not possess a `role` attribute. The add-on items have the `role` attribute set to `add-on`.

The element `ce:include-item` possesses a `view` attribute. This can be used to include different items depending on the view. See the section on [Views](#).

If an item comprises just one page, the `ce:last-page` is not present.

## Rendering notes

It can happen that an `issue-sec` is not followed by another `issue-sec` but by further `ce:include-items`. In the example given above, this is the case for the “Cumulative author index” at the end of the issue. Visual separation is required in order to prevent the impression that the item belongs to be preceding `issue-sec`.

## issue-data

### Declaration

#### Model

```
<!ELEMENT issue-data          ( cover-date, ce:pages+, cover-image?,
                               issue-designation?, title-editors-
                               group* )>
```

### Description

The element `issue-data` contains the data belonging to the issue itself.

### Usage

The element `issue-data` consists of `cover-date`, the mandatory cover date; `ce:pages`, a series of one or more page ranges, detailing the page ranges that occur in the issue; `cover-image`, an optional image of the (paper) issue’s cover; `issue-designation`, an optional subtitle or section of the serial publication; and optional title, editors, conference information, etc., in `title-editors-group`.

The page ranges of the issue, captured with a series of `ce:pages`, include only the “interior” page ranges of the serial issue, unless front- or backmatter ranges are of great importance.

#### XML

```
<ce:pages>
  <ce:first-page>1</ce:first-page>
  <ce:last-page>300</ce:last-page>
</ce:pages>
<ce:pages>
  <ce:first-page>L1</ce:first-page>
  <ce:last-page>L38</ce:last-page>
</ce:pages>
```

#### Presentation

Possible rendering: *Pages 1–300, L1–L38*

A journal issue or book series volume can be associated with more than one conference, e.g. two thin special issues in one issue. For this reason there can be more than one `title-editors-group`. It is, however, impossible to indicate which items in the serial issue are associated with which title and editors group — this can only be made clear by using meaningful `issue-secs`.

For more information about the remaining subelements of `issue-data`, see these subelements.

# issue-designation

## Declaration

### Model

```
<!ELEMENT issue-designation ( %richstring.data; )*>
```

## Description

The element `issue-designation` contains a subtitle or section of the serial publication to which the issue belongs.

## Usage

For some publications, the issues belong to a certain section or “sub-journal” or “sub-series”. The element `issue-designation` can be used to store that information.

### XML

```
<issue-designation>Logic, semantics and theory of  
programming</issue-designation>
```

### XML

```
<issue-designation>Field Theory and  
Statistical Systems</issue-designation>
```

### Explanation

The issues of the journal *Theoretical Computer Science* carry a subtitle “Algorithms, complexity and games” or “Logic, semantics and theory of programming”. The issues of the journal *Nuclear Physics B* carry a subtitle “Field Theory and Statistical Systems”, “Physical Mathematics” or “Particle Physics”. This is the way to capture that property of the issue.

## issue-info

### Declaration

#### Model

```
<!ELEMENT issue-info          ( ce:pri, ce:doi?, jid, ce:issn,
                               volume-issue-number, ce:isbn? )>
```

### Description

The element `issue-info` contains the identifiers that uniquely identify the issue.

### Usage

An issue in a serial publication has several equivalent identifiers that can be used to retrieve the issue.

An issue has its own “publishable item identifier”, PII, stored within `ce:pri`. An optional digital object identifier, DOI can also be assigned to the issue, `ce:doi`. The issue PII may have an “X” in the first position of the five-digit component.

An alternative form of issue identification is by the Elsevier internal system code, called JID (an abbreviation of journal ID) and volume/issue number. The serial publication is identified in two ways: by code, `jid` and by the ISSN, `ce:issn`. In view of publication evolution and the importance of correctly assigning an issue to a publication, both are present. The volume/issue number is captured using the subelement `volume-issue-number`.

Finally, some serial publications assign ISBNs to their volumes or issues, e.g. in the case of all book series. The optional `ce:isbn` is used to store the ISBN.

#### XML

```
<issue-info>
  <ce:pri>S9999-9994(03)X7607-2</ce:pri>
  <jid>ENDEND</jid>
  <ce:issn>9999-9994</ce:issn>
  <volume-issue-number>
    <vol-first>31</vol-first>
    <iss-first>5</iss-first>
  </volume-issue-number>
</issue-info>
```

## issue-sec

### Declaration

#### Model

```

<!ELEMENT issue-sec          ( ce:section-title?, ( ce:include-item |
                               issue-sec )+ )>
<!ATTLIST issue-sec
    id             ID             #IMPLIED
    role          CDATA          #IMPLIED>

```

### Description

The element [issue-sec](#) is used to group items within the issue under a common heading.

### Usage

Many issues contain a hierarchical structure of their items. This structure usually reveals itself in the table of contents, that may contain first-order headings or higher-order headings. This grouping of items is accomplished using the element [issue-sec](#). It consists of a [ce:section-title](#) containing the heading, a number of included items and/or nested item sections.

Although [ce:section-title](#) is declared optional in the DTD, it must always be present.

For more information, see [issue-body](#).



# **jid**

## **Declaration**

### **Model**

```
<!ELEMENT jid ( %string.data; )*>
```

## **Description**

The element [jid](#) contains the Elsevier system code of the serial publication.

## **See also**

[ce:pii](#), [ce:doi](#)

## serial-issue

### Declaration

#### Model

```

<!ELEMENT serial-issue ( issue-info, issue-data, issue-body )>
<!ATTLIST serial-issue
  xmlns CDATA #FIXED %ESSI.xmlns;
  version CDATA #FIXED '5.1'
  xmlns:ce CDATA #FIXED %ESCE.xmlns;
  xmlns:sb CDATA #FIXED %ESSB.xmlns;
  xmlns:xlink CDATA #FIXED %XLINK.xmlns;
  xml:lang %language; 'en'>

```

### Description

The element `serial-issue` contains a serial issue.

### Usage

The element `serial-issue` is the top-level element (single doctype) of the SI DTD. It is used for structuring serial issues. It captures the data of the issue, and acts as a “hub” for the items in the issue.

There are several attributes of the element, as follows.

- The attribute `xml:lang` specifies the language in which the properties of the issue is written in the XML file. It can adopt the values English (`en`, default) French (`fr`), German (`de`), Italian (`it`), Portuguese (`pt`), Russian (`ru`), Spanish (`es`).
- The fixed attribute `xmlns` sets the default namespace for SI elements, and the other fixed attributes beginning with `xmlns:` set the prefix and the namespace of elements used in the DTD, e.g. those of the common element pool (`xmlns:ce` and `xmlns:sb`) and of the XLink standard (`xmlns:xlink`). Since these attributes are fixed, they need not be specified as they are inferred by the parser.
- `version` is fixed to 5.1, i.e. the first two digits of the version of the DTD.

Figures 6 and 7 on the following pages show an example of a serial issue.

## TABLE OF CONTENTS

	<b>May 2, 2003: 113 (3)</b> <b>"Functional Specificity of Small GTPases"</b> <b>[Cover Caption]</b>	
<b>Browse Archive:</b>		
← →		
<b>Previews ↑</b>		
	<b>p53 and TGF-<math>\beta</math> in Development: Prelude to Tumor Suppression?</b> Malcolm Whitman and Frank McKeon [Summary] [Full Text] [PDF]	<b>Pages</b> <b>275-276</b>
	<b>tRNA Structure Goes from L to »</b> Paul Schimmel and Koji Tamura [Summary] [Full Text] [PDF]	<b>276-278</b>
	<b>Coordinate Regulation of an Extended Chromosome Domain</b> Vincent C. Calhoun and Michael Levine [Summary] [Full Text] [PDF]	<b>278-280</b>
<b>Minireview ↑</b>		
	<b>The Stem Cell Concept in Plants: A Matter of Debate</b> Thomas Laux [Summary] [Full Text] [PDF]	<b>Pages</b> <b>281-283</b>
<b>Articles ↑</b>		
	<b>Stereotyped Pruning of Long Hippocampal Axon Branches Triggered by Retraction Inducers of the Semaphorin Family</b> Anil Bagri, Hwai-Jong Cheng, Avraham Yaron, Samuel J. Pleasure, and Marc Tessier-Lavigne [Summary] [Full Text] [PDF] [Supplementary Data]	<b>Pages</b> <b>285-299</b>
...		
<hr/>		
	<b>↑</b> On the cover: The cover shows eight of the distinct cell morphology classes that were induced by expression of constitutively active Ras superfamily small GTPases. NIH3T3 fibroblasts were transfected with 100 different mutant small GTPases and the observed morphologies were grouped into different classes. The cell in the middle is a cell transfected with a control construct. For further information, please see the article by Heo and Meyer in this issue (pp. <a href="#">369-381</a> ).	

Figure 6: Example of an issue table of contents complete with cover image and a caption. (Based on a real-life [example](#).) Its XML encoding can be found in Figure 7.

---

```

<?xml version="1.0" encoding="UTF-8"?>
<!DOCTYPE serial-issue
  PUBLIC "-//ES//DTD serials issue DTD version 5.1.0//EN//XML"
  "si510.dtd" [
  <!ENTITY cover SYSTEM "cover" NDATA IMAGE>
]>
<serial-issue>
  <issue-info>
    <ce:pii>S0092-8674(03)X0400-6</ce:pii>
    <jid>CELL</jid>
    <ce:issn>0092-8674</ce:issn>
    <volume-issue-number>
      <vol-first>113</vol-first>
      <iss-first>3</iss-first>
    </volume-issue-number>
  </issue-info>
  <issue-data>
    <cover-date>
      <date-range>
        <start-date>20030502</start-date>
      </date-range>
    </cover-date>
    <ce:pages>
      <ce:first-page>275</ce:first-page>
      <ce:last-page>419</ce:last-page>
    </ce:pages>
    <cover-image>
      <ce:figure>
        <ce:label>Functional Specificity of Small GTPases</ce:label>
        <ce:caption>
          <ce:simple-para>The cover shows eight of the distinct cell
            morphology classes that were induced by expression of
            constitutively active Ras superfamily small GTPases. NIH3T3
            fibroblasts were transfected with 100 different mutant small
            GTPases and the observed morphologies were grouped into
            different classes. The cell in the middle is a cell
            transfected with a control construct. For further
            information, please see the article by Heo and Meyer in this
            issue (pp. <ce:inter-ref xlink:href="doi:10.1016/
            S0092-8674(03)00307-6">369-381</ce:inter-ref>).</ce:simple-para>
          </ce:caption>
          <ce:link locator="cover"/>
        </ce:figure>
      </cover-image>
    </issue-data>
    <issue-body>
      <issue-sec>
        <ce:section-title>Previews</ce:section-title>
        <ce:include-item>
          <ce:pii>S0092-8674(03)00317-9</ce:pii>
          <ce:doi>10.1016/S0092-8674(03)00317-9</ce:doi>
          <ce:pages>
            <ce:first-page>275</ce:first-page>
            <ce:last-page>276</ce:last-page>
          </ce:pages>
        </ce:include-item>
      </issue-sec>
    </issue-body>
  </serial-issue>

```

```

<ce:include-item>
  <ce:pII>S0092-8674(03)00313-1</ce:pII>
  <ce:doi>10.1016/S0092-8674(03)00313-1</ce:doi>
  <ce:pages>
    <ce:first-page>276</ce:first-page>
    <ce:last-page>278</ce:last-page>
  </ce:pages>
</ce:include-item>
<ce:include-item>
  <ce:pII>S0092-8674(03)00309-X</ce:pII>
  <ce:doi>10.1016/S0092-8674(03)00309-X</ce:doi>
  <ce:pages>
    <ce:first-page>278</ce:first-page>
    <ce:last-page>280</ce:last-page>
  </ce:pages>
</ce:include-item>
</issue-sec>
<issue-sec>
  <ce:section-title>Minireview</ce:section-title>
  <ce:include-item>
    <ce:pII>S0092-8674(03)00312-X</ce:pII>
    <ce:doi>10.1016/S0092-8674(03)00312-X</ce:doi>
    <ce:pages>
      <ce:first-page>281</ce:first-page>
      <ce:last-page>283</ce:last-page>
    </ce:pages>
  </ce:include-item>
</issue-sec>
<issue-sec>
  <ce:section-title>Articles</ce:section-title>
  <ce:include-item>
    <ce:pII>S0092-8674(03)00267-8</ce:pII>
    <ce:doi>10.1016/S0092-8674(03)00267-8</ce:doi>
    <ce:pages>
      <ce:first-page>285</ce:first-page>
      <ce:last-page>299</ce:last-page>
    </ce:pages>
  </ce:include-item>
  ...
</issue-sec>
  ...
</issue-body>
</serial-issue>

```

Figure 7: XML encoding of the issue table of contents shown in Figure 6.

## sponsor

### Declaration

#### Model

```
<!ELEMENT sponsor ( %richstring.data; )*>
```

### Description

The element [sponsor](#) contains sponsor text for a conference.

### Usage

See [sponsors](#).

## sponsors

### Declaration

#### Model

```
<!ELEMENT sponsors ( sponsor+ )>
```

### Description

The element `sponsors` contains information about one or more sponsors of a conference or sponsors of the serial issue.

### Usage

When a conference or a journal issue or book series volume is sponsored, the element `sponsors` is used to capture this information.

The element `sponsor` does not generate any text itself, therefore the full “sponsored by” text is captured within `sponsor`.

*XML*

```
<sponsors>
  <sponsor>Sponsored by Reckitt Benckiser Pharmaceuticals</sponsor>
</sponsors>
```

*XML*

```
<sponsors>
  <sponsor>Sponsored by Reckitt Benckiser Pharmaceuticals
    and GlaxoSmithKline</sponsor>
</sponsors>
```

*XML*

```
<sponsors>
  <sponsor>This issue was partially funded by a grant from the
    Clay Mathematics Institute</sponsor>
</sponsors>
```

The second example shows that it is possible to have two sponsors within `sponsor`. If there is the need to have more than one sponsor text it is possible to use more `sponsor` elements. Examples of this are sponsor texts in different languages or texts of a different nature that one would like to separate.

*XML*

```
<sponsors>
  <sponsor>Sponsored by Reckitt Benckiser Pharmaceuticals</sponsor>
  <sponsor>The conference was made possible by a grant from the
    National Science Foundation</sponsor>
</sponsors>
```

*XML*

```
<sponsors>
  <sponsor>Sponsored by Reckitt Benckiser Pharmaceuticals</sponsor>
  <sponsor>Gesponsort durch Reckitt Benckiser Pharmaceuticals</sponsor>
</sponsors>
```

## start-date

### Declaration

#### Model

```
<!ELEMENT start-date ( %string.data; )*>
```

### Description

The element [start-date](#) contains the start date of a date range in EFFECT format.

### Usage

See [date-range](#).



# suppl

## Declaration

### Model

```
<!ELEMENT suppl ( %string.data; )*>
```

## Description

The element [suppl](#) contains the supplementary designation within the volume/issue number of the journal issue, for supplements, parts and indexes.

## Usage

See [volume-issue-number](#).

## title-editors-group

### Declaration

#### Model

```
<!ELEMENT title-editors-group ( (%titles;)?, conference-info?, ( editors | ce:editors )?, sponsors? )>
```

### Description

The element `title-editors-group` contains information belonging to a serial issue.

### Usage

The element `title-editors-group` contains information about the serial issue, such as its title, its editors, etc.

Journal issues are either “regular” or “special”. Special issues also include proceedings and thematical or topical issues. They have additional properties above those of a regular issue. In particular, they may possess a title, (guest) editors, and can belong to a conference.

A volume in a book series can also have one or more of these properties.

The element `title-editors-group` is provided for capturing the above-mentioned properties of a serial issue. An issue can have zero or more of these elements. If it has none, then the issue must be regular. If it has more than one, then it indicates that the issue in fact contains more than one “special issue”; there is, however, no means to link the items with this element.

The title of the serial issue can be captured with `ce:title`. In addition to the title, there can optionally be a subtitle (`ce:subtitle`), titles in an alternative language (`ce:alt-title`), and subtitles in an alternative language (`ce:alt-subtitle`).

If the serial issue is related to a conference, then the details of that conference is contained in `conference-info`.

Serial issues may have (guest) editors. These can be captured in two alternative ways. One is in the form of an unstructured string of names (`editors`), the other is a structured list of editors (`ce:editors`, for more information see the description of that element). These (guest) editors should not be confused with the Editorial Board members. Those are captured in a separate document with `docsubtype` equal to `edb`.

One or more sponsors can be associated with the issue (or with the conference). These are captured within `sponsors`.

#### XML

```
<title-editors-group>
  <ce:title>Restless Legs Syndrome</ce:title>
  <ce:editors>
    <ce:author-group>
      <ce:author>
        <ce:degrees>Dr</ce:degrees>
        <ce:given-name>Sudhansu</ce:given-name>
        <ce:surname>Chokroverty</ce:surname>
      </ce:author>
    </ce:author-group>
  </ce:editors>
</title-editors-group>
```

```

    </ce:author>
    <ce:affiliation>
      <ce:textfn>Saint Vincents Hospital and
        Medical Center, 153 West 11th St., Cronin 466,
        New York, NY 10011, USA</ce:textfn>
    </ce:affiliation>
  </ce:author-group>
</ce:editors>
</title-editors-group>

<title-editors-group>
  <ce:title>Buprenorphine and Buprenorphine/Naloxone:
    A Guide For Clinicians</ce:title>
  <editors>Paul J. Fudala and T. Peter Bridge</editors>
  <sponsors>
    <sponsor>Supported by Reckitt Benckiser Pharmaceuticals
      Inc.</sponsor>
  </sponsors>
</title-editors-group>

<title-editors-group>
  <ce:title>Statphys-Taiwan-2002:
    Lattice Models and Complex Systems</ce:title>
  <conference-info>
    <venue>Taipei and Taichung, Taiwan</venue>
    <date-range>
      <start-date>20020526</start-date>
      <end-date>20020601</end-date>
    </date-range>
  </conference-info>
  <editors>Chin-Kun Hu and K.-t. Leung</editors>
</title-editors-group>

```

Element `editors` is provided for backward compatibility with the EFFECT dataset . toc dataset description file.

## venue

### Declaration

#### Model

```
<!ELEMENT venue ( %richstring.data; )*>
```

### Description

The element [venue](#) contains the location where the conference took place.

### Usage

See [conference-info](#).

## vol-first

### Declaration

#### Model

```
<!ELEMENT vol-first ( %string.data; )*>
```

### Description

The element `vol-first` contains the volume number, or the first volume in a volume number range, of a serial issue.

### Usage

See [volume-issue-number](#).

## vol-last

### Declaration

#### Model

```
<!ELEMENT vol-last ( %string.data; )*>
```

### Description

The element `vol-last` contains the last volume in a volume number range of a serial issue.

### Usage

See [volume-issue-number](#).

## volume-issue-number

### Declaration

#### Model

```
<!ELEMENT volume-issue-number ( vol-first, (( vol-last, suppl ) |
                                     ( iss-first, iss-last?, suppl? ) |
                                     suppl ))>
```

### Description

The element `volume-issue-number` contains the volume/issue number of the issue.

### Usage

Each issue has a “volume/issue number”, which can be broken into different parts: the volume or volume range, the issue or issue range, and the supplementary information. This is captured in up to five elements, `vol-first`, `vol-last`, `iss-first`, `iss-last`, `suppl`.

The `suppl` element may only contain the following:

- C, for “complete”
- P, for “part”, optionally followed by a single digit or a capital letter
- I, for “index”, optionally followed by a single or a double digit number or a capital letter
- S, for “supplement”, optionally followed by a single or a double digit number or a capital letter

In the case of a P100 delivery the `suppl` element may also contain an F, for “spin-off”, optionally followed by a single digit, or one of the above options followed by F optionally followed by a single digit.

#### XML

```
<volume-issue-number>
  <vol-first>4</vol-first>
  <iss-first>4</iss-first>
</volume-issue-number>

<volume-issue-number>
  <vol-first>192</vol-first>
  <iss-first>1</iss-first>
  <iss-last>3</iss-last>
</volume-issue-number>

<volume-issue-number>
  <vol-first>227</vol-first>
  <vol-last>228</vol-last>
  <suppl>C</suppl>
</volume-issue-number>

<volume-issue-number>
  <vol-first>50</vol-first>
  <suppl>I</suppl>
</volume-issue-number>
```

```
<volume-issue-number>  
  <vol-first>73</vol-first>  
  <suppl>S1</suppl>  
</volume-issue-number>
```

```
<volume-issue-number>  
  <vol-first>42</vol-first>  
  <vol-last>45</vol-last>  
  <suppl>PB</suppl>  
</volume-issue-number>
```

*Presentation*

4/4

192/1–3

227–228

Vol. 50, Master Index

Vol. 73, Supplement 1

Vols. 42–45, Part B



# Chapter 5

## Book DTD

This chapter contains an alphabetic listing of the elements in the Elsevier Book DTD and its predecessor, the Elsevier Health Sciences Book DTD. This DTD has the following top-level elements: `book`, `chapter`, `simple-chapter`, `examination`, `fb-non-chapter`, `glossary`, `index`, `introduction`, `bibliography`. These top-level elements provide the option to define the *structure* of the book (`book`) and the *content* of the book (the other top-level elements). The former contains metadata and hierarchy of the book project, and it “calls” the chapters, the index, etc. using the `ce:include-item` element. This is why it is often referred to as the “hub” of the book.

In serial publications, items and issue hubs are structured with two different DTDs, the JA DTD and the SI DTD. This is due to historical reasons. In the Elsevier Book DTD, all aspects of a book are supported.

### CEP version used in this DTD

The Book DTD versions described in this documentation make use of different versions of the common element pool, as follows:

Book DTD	Common element pool
EHS Book DTD 5.1.0	CEP 1.1.2
EHS Book DTD 5.1.1	CEP 1.1.3
Book DTD 5.2.0	CEP 1.1.3
Book DTD 5.2.1	CEP 1.1.3
Book DTD 5.3.0	CEP 1.1.6

### Parameter entities

The Book DTDs use the local parameter entities `%local.spar.data`; and `%local.par.data`; to add element `ce:index-flag` to parameter entities `%spar.data`; and `%par.data`; . The effect is that `ce:index-flag` can be used in any element that has `%spar.data`; or `%par.data`; in its model. In the same way it adds `ce:br` to parameter entity `%textfn.data`;

```
<!ENTITY % local.spar.data    "| ce:index-flag">
<!ENTITY % local.par.data     "| ce:index-flag">
<!ENTITY % local.textfn.data  "| ce:br">
```

# bibliography

## Declaration

### Model (Book DTD 5.1.0, Book DTD 5.1.1)

```
<!ELEMENT bibliography      ( info, ce:further-reading+ )>
<!ATTLIST bibliography
  id                ID                #REQUIRED
  xmlns             CDATA             #FIXED %ES.xmlns;
  version           CDATA             #FIXED '5.1'
  xmlns:ce          CDATA             #FIXED %ESCE.xmlns;
  xmlns:xlink       CDATA             #FIXED %XLINK.xmlns;
  xml:lang          %language;        'en'
  docsubtype        %docsubtype;      #FIXED "bib">
```

### Model (Book DTD 5.2.0, Book DTD 5.2.1)

```
<!ELEMENT bibliography      ( info, ce:label?, ce:further-
                             reading* )>
<!ATTLIST bibliography
  id                ID                #REQUIRED
  xmlns             CDATA             #FIXED %ESBK.xmlns;
  version           CDATA             #FIXED '5.2'
  xmlns:ce          CDATA             #FIXED %ESCE.xmlns;
  xmlns:xlink       CDATA             #FIXED %XLINK.xmlns;
  xml:lang          %language;        'en'
  role              CDATA             #IMPLIED
  docsubtype        %docsubtype;      #FIXED "bib">
```

### Model (Book DTD 5.3.0)

```
<!ELEMENT bibliography      ( info, ce:label?, ce:title?,
                             ce:further-reading* )>
<!ATTLIST bibliography
  xmlns             CDATA             #FIXED %ES.xmlns;
  version           CDATA             #FIXED '5.3'
  xmlns:ce          CDATA             #FIXED %ESCE.xmlns;
  xmlns:xlink       CDATA             #FIXED %XLINK.xmlns;
  xml:lang          %iso639;         'en'
  id                ID                #REQUIRED
  role              CDATA             #IMPLIED
  docsubtype        %docsubtype;      #FIXED "bib">
```

## Description

The element [bibliography](#) is used to capture book-level bibliographies that sometimes appear in a book's back matter.

## Usage

The [bibliography](#) element is used to capture a book-level bibliography when they appear in the back matter of a book. When used, [bibliography](#) will always appear as a top-level element, with its own DOCTYPE declaration/PUBLIC identifier appearing at the top of the XML file. A [bibliography](#) gets called into the book's hub XML file by a [ce:include-item](#) element.

Content for `bibliography` consists of required `info` followed by optional `ce:label`, optional `ce:title`, and optional/repeatable `ce:further-reading`.

It has an optional `role`, along with several required attributes:

- `xmlns` `http://www.elsevier.com/xml/book/dtd`
- `version` 5.3
- `xmlns:ce` `http://www.elsevier.com/xml/common/dtd`
- `xmlns:xlink` `http://www.w3.org/1999/xlink`
- `xml:lang` `en`
- `id`
- `docsubtype` `bib`.

#### XML

```
<!DOCTYPE bibliography PUBLIC "-//ES//DTD book DTD
version 5.3.0//EN//XML" "book530.dtd" []>
<bibliography docsubtype="bib" id="bibliog">
  <info>
    <ce:pII>B978-0-323-01679-7.10003-8</ce:pII>
    <ce:ISBN>978-0-323-01679-7</ce:ISBN>
    <ce:copyright type="full-transfer" year="2003">Mosby, Inc.</ce:copyright>
  </info>
  <ce:title>Bibliography</ce:title>
  <ce:further-reading>
    ...
  </ce:further-reading>
</bibliography>
```

### Version history

In the Elsevier Book DTD 5.2.0 the optional attribute `role` and optional subelement `ce:label` were added, and `ce:further-reading` was made optional/repeatable to allow for Ultra-light delivery of book backfile projects.

In the Elsevier Book DTD 5.3.0 the `ce:title` was added to allow for proper title and tagging in synch with other DOCTYPES.

The `ce:section-title` element, child of `ce:bibliography` should no longer be used for Bibliography item titles.

# body

## Declaration

### Model (Book DTD 5.1.0–Book DTD 5.2.1)

```
<!ELEMENT body ( volume | part | section | ce:include-
                item )+>
```

### Model (Book DTD 5.3.0)

```
<!ELEMENT body ( volume | part | section | ce:include-
                item )+>
<!ATTLIST body
    role                CDATA                #IMPLIED>
```

## Description

The element `body` is used to capture all of the material that appears between the front and rear of Elsevier books.

## Usage

The `body` element is used to delimit and capture the material that appears between the front and rear in Elsevier books. It consists of required and repeatable `volumes` and/or `parts` and/or `sections` and/or `ce:include-items`.

It has an optional `role`.

The only time the role attribute should be used is for Major Reference Works (MRWs). The values "enc" for Encyclopedias or "com" for Comprehensives.

The element `body`, child of `book`, appears in the hub file for the book. If present, any hierarchy above chapters (e.g. volume, parts, sections) should also be captured using this content model within the hub file.

Lower-level items (doctypes chapter, introduction, examination, and in very rare cases bibliography) within the body get called in to the hub file using `ce:include-item` elements. Other doctypes usually do not get called into `body`.

### XML

```
<body>
  <volume id="vI"><ce:label>Volume I</ce:label>
  <part id="pA"><ce:label>Part A</ce:label>
    <ce:title>GENERAL ISSUES AND APPROACH TO DISEASE
      IN PRIMARY CARE MEDICINE</title>
    <ce:include-item>
      <ce:pii>B0-323-01679-0/10027-7</ce:pii>
      <ce:title>Introduction</ce:title>
      <ce:pages>
        <ce:first-page>1</ce:first-page>
        <ce:last-page>8</ce:last-page>
      </ce:pages>
    </ce:include-item>
  <section id="s1"><ce:label>Section 1</ce:label>
    <ce:title>Core Issues and Special Groups
```

```
        in Primary Care</ce:title>
    <ce:include-item>
        <ce:pii>B0-323-01679-0/10003-4</ce:pii>
        <ce:title>Core Issues in Primary Care</ce:title>
        <ce:pages>
            <ce:first-page>9</ce:first-page>
            <ce:last-page>18</ce:last-page>
        </ce:pages>
    </ce:include-item>
    ...
</section>
...
</part>
...
</volume>
</body>
```

Version 5.3 added optional role attribute to allow for proper tagging of MRWs.

# book

## Declaration

### Model (Book DTD 5.2.0)

```

<!ELEMENT book ( info, top, ce:floats?, front, body,
                rear )>
<!ATTLIST book
  xmlns CDATA #FIXED %ESBK.xmlns;
  version CDATA #FIXED '5.2'
  xmlns:ce CDATA #FIXED %ESCE.xmlns;
  xmlns:xlink CDATA #FIXED %XLINK.xmlns;
  xml:lang %language; 'en'
  docsubtype %docsubtype; #FIXED "bk">

```

### Model (Book DTD 5.2.1)

```

<!ELEMENT book ( info, top, ce:floats?, front?, body,
                rear? )>
<!ATTLIST book
  xmlns CDATA #FIXED %ESBK.xmlns;
  version CDATA #FIXED '5.2'
  xmlns:ce CDATA #FIXED %ESCE.xmlns;
  xmlns:xlink CDATA #FIXED %XLINK.xmlns;
  xml:lang %language; 'en'
  docsubtype %docsubtype; #FIXED "bk">

```

### Model (Book DTD 5.3.0)

```

<!ELEMENT book ( info, top, ce:floats?, front?, body,
                rear? )>
<!ATTLIST book
  xmlns CDATA #FIXED %ES.xmlns;
  version CDATA #FIXED '5.3'
  xmlns:ce CDATA #FIXED %ESCE.xmlns;
  xmlns:xlink CDATA #FIXED %XLINK.xmlns;
  xml:lang %iso639; 'en'
  docsubtype %docsubtype-book; "bk">

```

## Description

The element `book` is the top-level element for Elsevier books. A majority of books should be able to be captured using the content model from this DTD.

## Usage

A Book dataset can be used to capture most Elsevier book publications.

Book content consists of a hub file used to reflect hierarchy in body above chapter, as well as to call all of the lower-level doctypes (e.g. chapter, index) into the book. Contrary to serial publications, where the item and the hub have different DTDs for historical reasons, the hub and items of an Elsevier book are structured with different top-level elements (doctypes) of the same DTD.

The hub's top-level element is `book`. It consists of required `info` and `top`, optional `ce:floats` and optional `front`, required `body`, and optional `rear` elements.

It has several required attributes:

- `xmlns:` <http://www.elsevier.com/xml/book/dtd>
- `version:` 5.2
- `xmlns:ce:` <http://www.elsevier.com/xml/common/dtd>
- `xmlns:xlink:` <http://www.w3.org/1999/xlink>
- `xml:lang:` en (default value)
- `docsubtype-book:` bk (default value)

*XML*

```

<!DOCTYPE book
  PUBLIC "-//ES//DTD book DTD version 5.3.0//EN//XML"
  "book530.dtd" []>
<book>
  <info>
    ...
  </info>
  <top>
    ...
  </top>
  <front>
    ...
  </front>
  <body>
    ...
  </body>
  <rear>
    ...
  </rear>
</book>

```

**Version history**

In the Elsevier Book DTD 5.2.0 the top-level element changed from `ehs-book` to `book`. The subelement `top` was added as was the attribute `docsubtype` with fixed value `bk`.

In the Elsevier Book DTD 5.2.1 subelements `front` and `rear` were made optional.

In the Elsevier Book DTD 5.3.0, changed from a fixed value of `docsubtypebk`, to `docsubtype-bookbk`.

# chapter

## Declaration

### Model (Book DTD 5.1.0)

```

<!ELEMENT chapter ( info, ce:floats?, ce:label, ce:title,
ce:subtitle?, ce:author-group*,
ce:displayed-quote?, ce:nomenclature?,
ce:intro?, ( ce:section | subchapter
| exam )+, ( ( ce:bibliography |
ce:further-reading )+, ( ce:section |
exam )* )? )>

<!ATTLIST chapter
  id ID #REQUIRED
  xmlns CDATA #FIXED %ES.xmlns;
  version CDATA #FIXED '5.1'
  xmlns:ce CDATA #FIXED %ESCE.xmlns;
  xmlns:xlink CDATA #FIXED %XLINK.xmlns;
  xml:lang %language; 'en'
  docsubtype %docsubtype; #FIXED "chp">

```

### Model (Book DTD 5.1.1)

```

<!ELEMENT chapter ( info, ce:floats?, ce:label, ce:title,
ce:subtitle?, ce:author-group*,
ce:displayed-quote?, poem?, outline?,
objectives?, ce:nomenclature?,
ce:intro?, ( ce:sections | subchapter
| exam )+, ( ( ce:bibliography |
ce:further-reading )+, ( ce:section |
exam )* )? )>

<!ATTLIST chapter
  id ID #REQUIRED
  xmlns CDATA #FIXED %ES.xmlns;
  version CDATA #FIXED '5.1'
  xmlns:ce CDATA #FIXED %ESCE.xmlns;
  xmlns:xlink CDATA #FIXED %XLINK.xmlns;
  xml:lang %language; 'en'
  docsubtype %docsubtype; #FIXED "chp">

```

### Model (Book DTD 5.2.0)

```

<!ELEMENT chapter ( ce:footnote*, info, ce:floats?,
ce:label, ce:title, ce:subtitle?,
ce:author-group*, ce:displayed-
quote?, poem?, outline?, objectives?,
ce:nomenclature?, ce:acknowledgment?,
ce:intro?, ( ce:sections | subchapter
| exam )+, ( ( ce:bibliography |
ce:further-reading )+, ( ce:section |
exam )* )? )>

<!ATTLIST chapter
  id ID #REQUIRED
  xmlns CDATA #FIXED %ESBK.xmlns;
  version CDATA #FIXED '5.2'
  xmlns:ce CDATA #FIXED %ESCE.xmlns;
  xmlns:xlink CDATA #FIXED %XLINK.xmlns;

```



```

xml:lang           %language;           'en'
role               CDATA                #IMPLIED
docsubtype        %docsubtype;         #FIXED "chp">

```

**Model (Book DTD 5.2.1)**

```

<!ELEMENT chapter ( ce:footnote*, info, ce:floats?,
                    ce:label?, ce:title, ce:subtitle?,
                    ce:author-group*, ce:displayed-
                    quote?, poem?, outline?, objectives?,
                    ce:nomenclature?, ce:acknowledgment?,
                    ce:intro?, ( ce:sections | subchapter
                    | exam )+, ( ( ce:bibliography |
                    ce:further-reading )+, ( ce:section |
                    exam )* )? )>

<!ATTLIST chapter
id                ID                    #REQUIRED
xmlns             CDATA                #FIXED %ESBK.xmlns;
version          CDATA                #FIXED '5.2'
xmlns:ce         CDATA                #FIXED %ESCE.xmlns;
xmlns:xlink      CDATA                #FIXED %XLINK.xmlns;
xml:lang         %language;           'en'
role             CDATA                #IMPLIED
docsubtype       %docsubtype;         #FIXED "chp">

```

**Model (Book DTD 5.3.0)**

```

<!ELEMENT chapter ( ce:footnote*, info, ce:floats?,
                    ce:label?, ce:title, ce:subtitle?,
                    ce:author-group*, ce:miscellaneous?,
                    ce:abstract*, ce:keywords*,
                    ce:displayed-quote?, poem?, out-
                    line?, objectives?, ce:nomenclature?,
                    ce:acknowledgment?, ce:intro?,
                    ( ce:sections | subchapter |
                    exam )+, ( ( ce:bibliography |
                    ce:further-reading )+, ( ce:section |
                    exam )* )? )>

<!ATTLIST chapter
xmlns             CDATA                #FIXED %ES.xmlns;
version          CDATA                #FIXED '5.3'
xmlns:ce         CDATA                #FIXED %ESCE.xmlns;
xmlns:xlink      CDATA                #FIXED %XLINK.xmlns;
xml:lang         %iso639;             'en'
id               ID                    #REQUIRED
role             CDATA                #IMPLIED
docsubtype       %docsubtype;         #FIXED "chp">

```

**Description**

The element [chapter](#) is used to capture book chapters as individual XML files.

**Usage**

The [chapter](#) element is used to capture all the material that appears within a book chapter. There is a PUBLIC identifier and a DOCTYPE declaration for chapter, and individual chapter files get called into the book's hub file using the [ce:include-item](#) element.

Although the DTD does not restrict where lower-level book doctypes get called into the hub file, the intent is for `chapter` only to be called into `body`, not in `front` or `rear`.

Content for chapter consists of an optional/repeatable `ce:footnote`, a required `info` and the optional `ce:floats` container. The chapter begins with the (optional) `ce:label`, containing the name of the chapter (“Chapter 4”), the chapter title, tagged via the `ce:title` and optional `ce:subtitle` and optional and repeatable `ce:author-group` containing authors and their affiliations. Followed by optional `ce:miscellaneous`, optional/repeatable `ce:abstract`, and optional/repeatable `ce:keywords`. The optional subelements `ce:displayed-quote`, `poem`, optional/repeatable `outline`, optional `objectives`, and optional `ce:nomenclature` also belong to the “head” of the chapter, followed by an optional `ce:acknowledgment`. An introduction or summary is contained in the optional `ce:intro`.

The main body of the chapter consists of a sequence of `ce:sections`, `subchapter` and/or `exam` elements, followed by optional/repeatable `ce:bibliography` and/or `ce:further-reading`, possibly followed by more `ce:sections` and/or `exams`.

It has an optional `role`, along with several required attributes:

- `id`
- `xmlns:` `http://www.elsevier.com/xml/book/dtd`
- `version:` `5.3`
- `xmlns:ce:` `http://www.elsevier.com/xml/common/dtd`
- `xmlns:xlink:` `http://www.w3.org/1999/xlink`
- `xml:lang:` `en` (default value)
- `docsubtype:` `chp`

#### XML

```
<!DOCTYPE chapter
PUBLIC "-//ES//DTD book DTD version 5.3.0//EN//XML"
"book530.dtd" []>
<chapter id="ch1">
  <info>
    <ce:pII>B978-0-323-01679-7.10003-8</ce:pII>
    <ce:ISBN>978-0-323-01679-7</ce:ISBN>
    <ce:copyright type="full-transfer"
      year="2003">Mosby, Inc.</ce:copyright>
  </info>
  <ce:floats>
    ...
  </ce:floats>
  <ce:label>Chapter 1</ce:label>
  <ce:title>Core Issues in Primary Care</ce:title>
  <ce:author-group>
    ...
  </ce:author-group>
  <ce:intro>
    <ce:para>Text of opening paragraph...</ce:para>
  </ce:intro>
  <ce:sections>
    <ce:section>
      <ce:label>1.1</ce:label>
      <ce:section-title>Summary of Primary Care
        Today</ce:section-title>
      <ce:para>Text of opening paragraph...</ce:para>
    </ce:section>
  </ce:sections>
</chapter>
```

```

    <ce:para>Text second paragraph...</ce:para>
  </ce:section>
<ce:section>
  <ce:label>1.2</ce:label>
  <ce:section-title>Core Issues</ce:section-title>
  <ce:para>Text of opening paragraph...</ce:para>
  <ce:para>Text second paragraph...</ce:para>
</ce:section>
</ce:sections>
<ce:bibliography>
  ...
</ce:bibliography>
</chapter>

```

## Version history

In EHS Books DTD 5.1.1 the occurrence indicator for `ce:author-group` changed from ? to \*. Element `examination` was replaced by `exam` and the `docsubtype` attribute was added. Elements `poem`, `outline` and `objectives` were added. Element `ce:section` was changed to `ce:sections` to allow chapters to begin with regular paragraphs.

In Elsevier Book DTD 5.2.0, an optional/repeatable `ce:footnote` was added to the beginning of the content model for `chapter`. The optional attribute `role` was also added.

In Elsevier Book DTD 5.2.1 subelement `ce:label` was made optional.

In Elsevier Book DTD 5.3.0 this release of the DTD added optional `ce:miscellaneous`, optional/repeatable `ce:abstract`, and optional/repeatable `ce:keywords`.

## Light reading

Note that PreCAP chapters should be done using the doctype `simple-chapter`.

## cover-image

### Declaration

#### Model (Book DTD 5.2.0–Book DTD 5.3.0)

```
<!ELEMENT cover-image ( ce:figure )>
```

### Description

The element `cover-image` is used to include cover images for Elsevier books.

### Usage

The content for `cover-image` consists of a single `ce:figure`.

*XML*

```
<cover-image>
  <ce:figure>...</ce:figure>
</cover-image>
```

### Version history

This element first appeared in Elsevier Book DTD 5.2.0. It is optional to be backward compatible with earlier versions of the DTD.

# dedication

## Declaration

### Model (Book DTD 5.2.0–Book DTD 5.3.0)

```
<!ELEMENT dedication          ( ce:simple-para+ )>
```

## Description

The element `dedication` is used to tag dedications from book-level authors or editors that often appear in a book's front matter material.

## Usage

Content for `dedication` consists of required/repeatable `ce:simple-para`.

*XML*

```
<dedication>
  <ce:simple-para>There are so many people I must thank for
    the help they provided me in the creation of this
    book...</ce:simple-para>
  <ce:simple-para>And what sort of husband and father would I be if I
    forgot to mention my wonderful wife and children...</ce:simple-para>
</dedication>
```

## Version history

This element first appeared in Elsevier Book DTD 5.2.0.

This element should no longer be used after DTD 5.2.0 as dedications are now captured as individual items within `front`. See the CAP guide documentation for detailed guidance.

## ehs-book

### Declaration

#### Model (Book DTD 5.1.0, Book DTD 5.1.1)

```

<!ELEMENT ehs-book          ( info, top, ce:floats?, front, body,
                             rear )>
<!ATTLIST ehs-book
  xmlns          CDATA          #FIXED %ES.xmlns;
  version        CDATA          #FIXED '5.1'
  xmlns:ce       CDATA          #FIXED %ESCE.xmlns;
  xmlns:xlink    CDATA          #FIXED %XLINK.xmlns;
  xml:lang       %language;     'en'
  docsubtype     %docsubtype;   #FIXED "ehs">

```

### Description

The element `ehs-book` is the top-level element for Elsevier Health Science books. A majority of books should be able to be captured using the content model from this DTD.

### Usage

An EHS Books dataset can be used to capture most Elsevier Health Science book publications.

Book content consists of a hub file used to reflect hierarchy in body above chapter, as well as to call all of the lower-level doctypes (e.g. chapter, index) into the book. Contrary to serial publications, where the item and the hub have different DTDs for historical reasons, the hub and items of an EHS book are structured with different top-level elements (doctypes) of the same DTD.

The hub's top-level element is `ehs-book`. It consists of required `info` and `top`, optional `ce:floats` and required `front`, `body`, and `rear` elements.

It has several required attributes:

- `xmlns`: `http://www.elsevier.com/xml/ehs-book/dtd`
- `version`: `5.1`
- `xmlns:ce`: `http://www.elsevier.com/xml/common/dtd`
- `xmlns:xlink`: `http://www.w3.org/1999/xlink`
- `xml:lang`: `en` (default value)
- `docsubtype`: `ehs`

#### XML

```

<!DOCTYPE ehs-book
  PUBLIC "-//ES//DTD ehs book DTD version 5.1.1//EN//XML"
  "ehs_book511.dtd" []>
<ehs-book>
  <info>
    ...
  </info>
  <top>
    ...

```

```
</top>
<front>
  ...
</front>
<body>
  ...
</body>
<rear>
  ...
</rear>
</ehs-book>
```

### Version history

In Book DTD the new element `top` was added and the attribute `docsubtype`.

This element is superseded by `book` from Book DTD 5.2 onwards.

## exam

### Declaration

#### Model (Book DTD 5.1.0–Book DTD 5.2.1)

```
<!ELEMENT exam ( ce:title?, ce:exam-questions,
                  ce:exam-answers? )>
```

#### Model (Book DTD 5.3.0)

```
<!ELEMENT exam ( ce:title?, ce:exam-questions,
                  ce:exam-answers? )>
<!ATTLIST exam
            id ID #IMPLIED
            role CDATA #IMPLIED>
```

### Description

The element `exam` is used to capture review questions that appear within many different types of books.

### Usage

Content for `exam` consists of an optional `ce:title`, required `ce:exam-questions` and optional `ce:exam-answers`.

It has an optional `id`, optional `role`, and optional `view`.

#### XML

```
<exam id="exam1">
  <ce:title>Quiz from Section 1</ce:title>
  <ce:exam-questions>
    <ce:section-title>Questions</ce:section-title>
    <ce:para>...</ce:para>
  </ce:exam-questions>
  <ce:exam-answers>
    <ce:section-title>Answers</ce:section-title>
    <ce:para>...</ce:para>
  </ce:exam-answers>
</exam>
```

In version 5.3.0, optional ID, ROLE, and VIEW attributes were added.



# examination

## Declaration

### Model (Book DTD 5.1.0, Book DTD 5.1.1)

```
<!ELEMENT examination      ( info, ce:floats?, ce:label?, ce:title,
                             ce:author-group*, ce:intro?, exam+ )>
<!ATTLIST examination
  id                ID                #REQUIRED
  xmlns             CDATA             #FIXED %ES.xmlns;
  version           CDATA             #FIXED '5.1'
  xmlns:ce          CDATA             #FIXED %ESCE.xmlns;
  xmlns:xlink       CDATA             #FIXED %XLINK.xmlns;
  xml:lang          %language;        'en'
  docsubtyp        %docsubtyp;        #FIXED "exm">
```

### Model (Book DTD 5.2.0, Book DTD 5.2.1)

```
<!ELEMENT examination      ( info, ce:floats?, ce:label?, ce:title,
                             ce:author-group*, ce:intro?, exam* )>
<!ATTLIST examination
  id                ID                #REQUIRED
  xmlns             CDATA             #FIXED %ESBK.xmlns;
  version           CDATA             #FIXED '5.2'
  xmlns:ce          CDATA             #FIXED %ESCE.xmlns;
  xmlns:xlink       CDATA             #FIXED %XLINK.xmlns;
  xml:lang          %language;        'en'
  role              CDATA             #IMPLIED
  docsubtyp        %docsubtyp;        #FIXED "exm">
```

### Model (Book DTD 5.3.0)

```
<!ELEMENT examination      ( info, ce:floats?, ce:label?, ce:title,
                             ce:author-group*, ce:intro?, exam* )>
<!ATTLIST examination
  xmlns             CDATA             #FIXED %ES.xmlns;
  version           CDATA             #FIXED '5.3'
  xmlns:ce          CDATA             #FIXED %ESCE.xmlns;
  xmlns:xlink       CDATA             #FIXED %XLINK.xmlns;
  xml:lang          %iso639;         'en'
  id                ID                #REQUIRED
  role              CDATA             #IMPLIED
  docsubtyp        %docsubtyp;        #FIXED "exm">
```

## Description

The element `examination` is used to capture review questions that appear as their own item within many different types of books.

## Usage

The `examination` element is one of the top-level elements (doctypes) of the Books DTD. It is used to capture a series of review questions when they appear as a separate item in their own XML file, using the `examination` DOCTYPE and PUBLIC identifier, and is called into the central hub file for the book using the `ce:include-item` element.

The content for `examination` consists of required `info`, optional `ce:floats`, optional `ce:label`, followed by required `ce:title`, optional/repeatable `ce:author-group`, optional `ce:intro`, followed by required/repeatable `exam`.

It has an optional `role`, along with several required attributes:

- `id`
- `xmlns`: `http://www.elsevier.com/xml/book/dtd`
- `version`: `5.3`
- `xmlns:ce`: `http://www.elsevier.com/xml/common/dtd`
- `xmlns:xlink`: `http://www.w3.org/1999/xlink`
- `xml:lang`: `en` (default value)
- `docsubtype`: `exm`

#### XML

```

<!DOCTYPE examination PUBLIC "-//ES//DTD book DTD
  version 5.3.0//EN//XML" "book530.dtd" []>
<examination id="exm1" docsubtype="exm">
  <info>
    <ce:pii>B978-0-323-01679-7.10003-8</ce:pii>
    <ce:isbn>978-0-323-01679-7</ce:isbn>
    <ce:copyright type="full-transfer"
      year="2003">Mosby, Inc.</ce:copyright>
  </info>
  <ce:floats>
    ...
  </ce:floats>
  <ce:label>Unit 1</ce:label>
  <ce:title>Core Issues in Primary Care</ce:title>
  <ce:author-group>
    ...
  </ce:author-group>
  <ce:intro>
    <ce:para>Text of opening paragraph...</ce:para>
  </ce:intro>
  <exam>
    <ce:title>Section 1</ce:title>
    <ce:exam-questions>
      <ce:section-title>Questions</ce:section-title>
      <ce:para>...</ce:para>
    </ce:exam-questions>
    <ce:exam-answers>
      <ce:section-title>Answers</ce:section-title>
      <ce:para>...</ce:para>
    </ce:exam-answers>
  </exam>
  <exam>
    <ce:title>Section 2</ce:title>
    <ce:exam-questions>
      <ce:section-title>Questions</ce:section-title>
      <ce:para>...</ce:para>
    </ce:exam-questions>
    <ce:exam-answers>
      <ce:section-title>Answers</ce:section-title>
      <ce:para>...</ce:para>
    </ce:exam-answers>
  </exam>

```

```
    </ce:exam-answers>  
  </exam>  
</examination>
```

## Version history

In Elsevier Book DTD 5.2.0 the optional attribute `role` was added and subelement `exam` became optional.

## fb-non-chapter

### Declaration

#### Model (Book DTD 5.1.0)

```
<!ELEMENT fb-non-chapter ( info, ce:floats?, ce:label?,
                           ce:title, ( ce:author-group
                                       | ce:nomenclature | ce:para |
                                       ce:section )*, ce:bibliography? )>

<!ATTLIST fb-non-chapter
  id                ID                #REQUIRED
  xmlns             CDATA             #FIXED %ES.xmlns;
  version           CDATA             #FIXED '5.1'
  xmlns:ce          CDATA             #FIXED %ESCE.xmlns;
  xmlns:xlink      CDATA             #FIXED %XLINK.xmlns;
  xml:lang          %language;        'en'
  docsubtype       %docsubtype;      #REQUIRED>
```

#### Model (Book DTD 5.1.1)

```
<!ELEMENT fb-non-chapter ( info, ce:floats?, ce:label?,
                           ce:title, ( ce:author-group
                                       | ce:nomenclature | ce:para |
                                       ce:section )*, ce:bibliography? ,
                                       ce:further-reading? )>

<!ATTLIST fb-non-chapter
  id                ID                #REQUIRED
  xmlns             CDATA             #FIXED %ES.xmlns;
  version           CDATA             #FIXED '5.1'
  xmlns:ce          CDATA             #FIXED %ESCE.xmlns;
  xmlns:xlink      CDATA             #FIXED %XLINK.xmlns;
  xml:lang          %language;        'en'
  docsubtype       %docsubtype;      #REQUIRED>
```

#### Model (Book DTD 5.2.0, Book DTD 5.2.1)

```
<!ELEMENT fb-non-chapter ( info, ce:floats?, ce:label?,
                           ce:title, ( ce:author-group
                                       | ce:nomenclature | ce:para |
                                       ce:section )*, ce:bibliography? ,
                                       ce:further-reading? )>

<!ATTLIST fb-non-chapter
  id                ID                #REQUIRED
  xmlns             CDATA             #FIXED %ESBK.xmlns;
  version           CDATA             #FIXED '5.2'
  xmlns:ce          CDATA             #FIXED %ESCE.xmlns;
  xmlns:xlink      CDATA             #FIXED %XLINK.xmlns;
  xml:lang          %language;        'en'
  role             CDATA             #IMPLIED
  docsubtype       %docsubtype;      #REQUIRED>
```

#### Model (Book DTD 5.3.0)

```
<!ELEMENT fb-non-chapter ( info, ce:floats?, ce:label?,
                           ce:title, ( ce:author-group
                                       | ce:nomenclature | ce:para |
                                       ce:section )*, ce:bibliography? ,
                                       ce:further-reading? )>
```

```

<!ATTLIST fb-non-chapter
  xmlns          CDATA          #FIXED %ES.xmlns;
  version        CDATA          #FIXED '5.3'
  xmlns:ce       CDATA          #FIXED %ESCE.xmlns;
  xmlns:xlink    CDATA          #FIXED %XLINK.xmlns;
  xml:lang       %iso639;       'en'
  id             ID             #REQUIRED
  role           CDATA          #IMPLIED
  docsubtype     %docsubtype;   #REQUIRED>

```

## Description

The element `fb-non-chapter` is used to capture special front and back matter non-chapter divisions as individual XML files.

## Usage

The `fb-non-chapter` top-level element is used to capture material that appears in items that occur within the front (such as foreword, preface, about the author, etc.) and back matter (such as appendices) of books. The element should not be used to capture chapters within the book body.

There is a PUBLIC identifier and DOCTYPE declaration for `fb-non-chapter`, and individual XML files get called into the front and rear of the book's central hub file using the `ce:include-item` element.

A `docsubtype` attribute is required. The possible values for this attribute include:

- `app`: Appendix
- `bio`: Biography or About the Author
- `for`: Foreword
- `pre`: Preface
- `ack`: Acknowledgments
- `ctr`: Contributors
- `rev`: Reviewers
- `htu`: How to Use this Publication
- `ded`: Dedication

Other values should not be used with `fb-non-chapter`.

The content of `fb-non-chapter` consists of a required `info`, optional `ce:floats`, an optional `ce:label`, an `ce:title`, followed by optional and repeatable group of `ce:author-group` `ce:nomenclature` and/or `ce:para` and/or `ce:sections` (the order is the order as these appear in the book) followed by an optional `ce:bibliography`, followed by optional `ce:further-reading`.

It has an optional `role`, along with several required attributes:

- `id`
- `xmlns`: `http://www.elsevier.com/xml/book/dtd`
- `version`: `5.3`
- `xmlns:ce`: `http://www.elsevier.com/xml/common/dtd`
- `xmlns:xlink`: `http://www.w3.org/1999/xlink`
- `xml:lang`: `en` (default value)
- `docsubtype`

*XML*

```

<!DOCTYPE fb-non-chapter
  PUBLIC "-//ES//DTD book DTD version 5.3.0//EN//XML"
  "book530.dtd" []>
<fb-non-chapter docsubtype="app" id="appA">
  <info>
    <ce:pii>B978-0-323-01679-7.10003-8</ce:pii>
    <ce:isbn>978-0-323-01679-7</ce:isbn>
    <ce:copyright type="full-transfer"
      year="2003">Mosby, Inc.</ce:copyright>
  </info>
  <ce:floats>
    ...
  </ce:floats>
  <ce:label>Appendix A</ce:label>
  <ce:title>Color Plates</ce:title>
  <ce:author-group>
    ...
  </ce:author-group>
  <ce:para>Text of opening paragraph...</ce:para>
  <ce:section>
    <ce:section-title>...</ce:section-title>
    <ce:para>...</ce:para>
  </ce:section>
  <ce:bibliography>
    ...
  </ce:bibliography>
</fb-non-chapter>

```

**Version history**

Element `ce:further-reading` was added in EHS Books DTD 5.1.1 to allow for unnumbered references.

In Elsevier Book DTD 5.2.0 the optional attribute `role` was added.

In a patch to Elsevier Book DTD 5.2.0 the docsubtype `ded` was added.

**Light reading**

In a PreCAP delivery where the files are structured according to the Elsevier Book DTD 5.2.0, an `fb-non-chapter` DOCTYPE is delivered with weight `UltraLight`.

## front

### Declaration

#### Model (Book DTD 5.1.0, Book DTD 5.1.1)

```
<!ELEMENT front ( ce:include-item )+>
```

#### Model (Book DTD 5.2.0–Book DTD 5.3.0)

```
<!ELEMENT front ( ce:include-item+ )>
```

### Description

The element `front` is used to capture the front matter of Elsevier books.

### Usage

The `front` element is used to delimit and capture the front matter material in Elsevier books. It consists of required and repeatable `ce:include-item` elements. The element `front`, child of `book`, appears in the hub file for the book.

- The table of contents will be only be delivered as part of the “fat” PDF file for printing. An electronic version of the table of contents is replicated by the hub file and could be used by downstream applications for this purpose.
- The list of contributing authors (`docsubtype: ctr`) and/or reviewers (`docsubtype: rev`) should each be converted as a separate `fb-non-chapter` file and called into `front` using `ce:include-item` elements.
- Foreword (`docsubtype: for`), Preface (`docsubtype: pre`), Acknowledgments (`docsubtype: ack`), and Biography (`docsubtype: bio`), should also be converted as separate `fb-non-chapter` files and called into `front` using `ce:include-item` elements.
- Information for title, copyright, and dedication pages should be captured using the `top` element and should not be converted as separate items within `front`.

#### XML

```
<front>
  <ce:include-item>
    <ce:pII>B0-323-01679-0/10027-7</ce:pII>
    <ce:title>Contributors</ce:title>
    <ce:pages>
      <ce:first-page>v</ce:first-page>
      <ce:last-page>vii</ce:last-page>
    </ce:pages>
  </ce:include-item>
  <ce:include-item>
    <ce:pII>B0-323-01679-0/10001-0</ce:pII>
    <ce:title>Reviewers</ce:title>
    <ce:pages>
      <ce:first-page>viii</ce:first-page>
      <ce:last-page>viii</ce:last-page>
    </ce:pages>
  </ce:include-item>
</ce:include-item>
```

```
<ce:pII>B0-323-01679-0/10002-2</ce:pII>
<ce:title>Preface</ce:title>
<ce:pages>
  <ce:first-page>ix</ce:first-page>
  <ce:last-page>x</ce:last-page>
</ce:pages>
</ce:include-item>
<ce:include-item>
  <ce:pII>B0-323-01679-0/10003-4</ce:pII>
  <ce:title>Acknowledgments</ce:title>
  <ce:pages>
    <ce:first-page>xi</ce:first-page>
    <ce:last-page>xi</ce:last-page>
  </ce:pages>
</ce:include-item>
</front>
```



# glossary

## Declaration

### Model (Book DTD 5.1.0, Book DTD 5.1.1)

```
<!ELEMENT glossary          ( info, ce:glossary+ )>
<!ATTLIST glossary
  id                ID                #REQUIRED
  xmlns             CDATA             #FIXED %ES.xmlns;
  version           CDATA             #FIXED '5.1'
  xmlns:ce         CDATA             #FIXED %ESCE.xmlns;
  xmlns:xlink      CDATA             #FIXED %XLINK.xmlns;
  xml:lang         %language;        'en'
  docsubtype       %docsubtype;     #FIXED "gls">
```

### Model (Book DTD 5.2.0, Book DTD 5.2.1)

```
<!ELEMENT glossary          ( info, ce:label?, ce:glossary* )>
<!ATTLIST glossary
  id                ID                #REQUIRED
  xmlns             CDATA             #FIXED %ESBK.xmlns;
  version           CDATA             #FIXED '5.2'
  xmlns:ce         CDATA             #FIXED %ESCE.xmlns;
  xmlns:xlink      CDATA             #FIXED %XLINK.xmlns;
  xml:lang         %language;        'en'
  role             CDATA             #IMPLIED
  docsubtype       %docsubtype;     #FIXED "gls">
```

### Model (Book DTD 5.3.0)

```
<!ELEMENT glossary          ( info, ce:label?, ce:title?,
                             ce:glossary* )>
<!ATTLIST glossary
  xmlns             CDATA             #FIXED %ES.xmlns;
  version           CDATA             #FIXED '5.3'
  xmlns:ce         CDATA             #FIXED %ESCE.xmlns;
  xmlns:xlink      CDATA             #FIXED %XLINK.xmlns;
  xml:lang         %iso639;         'en'
  id               ID                #REQUIRED
  role             CDATA             #IMPLIED
  docsubtype       %docsubtype;     #FIXED "gls">
```

## Description

The element `glossary` is used to capture glossaries of special terms that can appear in a book's back matter.

## Usage

The `glossary` element is used to capture a glossary of special terms when they appear in the back matter of a book. When used, `glossary` will always appear as a top-level element, with its own DOCTYPE declaration and PUBLIC identifier appearing at the top of the XML file. A glossary gets called into the book's hub file by a `ce:include-item` element.

Content for glossary consists of required `info`, followed by optional `ce:label`, optional `ce:title`, then optional/repeatable `ce:glossary`, followed by optional/repeatable `ce:bibliography` and/or `ce:further-reading`.

It has an optional `role`, along with several required attributes:

- `id`
- `xmlns:` `http://www.elsevier.com/xml/book/dtd`
- `version:` 5.3
- `xmlns:ce:` `http://www.elsevier.com/xml/common/dtd`
- `xmlns:xlink:` `http://www.w3.org/1999/xlink`
- `xml:lang:` en (default value)
- `docsubtype:` gls

#### XML

```
<!DOCTYPE glossary
  PUBLIC "-//ES//DTD book DTD version 5.3.0//EN//XML"
  "book530.dtd" []>
<glossary id="gloss" docsubtype="gls">
  <info>
    <ce:pii>B978-0-323-01679-7.10003-8</ce:pii>
    <ce:isbn>978-0-323-01679-7</ce:isbn>
    <ce:copyright type="full-transfer"
      year="2003">Mosby, Inc.</ce:copyright>
  </info>
  <ce:title>Glossary</ce:title>
  <ce:glossary>
    <glossary-sec>
      <ce:section-title>A</ce:section-title>
      <ce:glossary-entry>
        <ce:glossary-heading>aardvark</ce:glossary-heading>
        <ce:glossary-def>An unusual-looking, long-nosed creature
          that eats ants.</ce:glossary-def>
      </ce:glossary-entry>
      ...
    </glossary-sec>
  </ce:glossary>
</glossary>
```

## Version history

In Elsevier Book DTD 5.2.0 the optional attribute `role` and optional subelement `ce:label` were added. Subelement `ce:glossary` was made optional/repeatable to allow for Ultra-light delivery of book backfile projects.

In the Elsevier Book DTD 5.3.0 the `ce:title` was added to allow for proper title tagging in synch with other DOCTYPES. It also added `ce:bibliography` and/or `ce:further-reading` elements at the end of the content model.

The `ce:section-title` element, child of `ce:glossary` should no longer be used for Glossary item titles.

# index

## Declaration

### Model (Book DTD 5.1.0, Book DTD 5.1.1)

```
<!ELEMENT index ( info, ce:index+ )>
<!ATTLIST index
  id ID #REQUIRED
  xmlns CDATA #FIXED %ES.xmlns;
  version CDATA #FIXED '5.1'
  xmlns:ce CDATA #FIXED %ESCE.xmlns;
  xmlns:xlink CDATA #FIXED %XLINK.xmlns;
  xml:lang %language; 'en'
  docsubtype %docsubtype; #FIXED "idx">
```

### Model (Book DTD 5.2.0, Book DTD 5.2.1)

```
<!ELEMENT index ( info, ce:label?, ce:index* )>
<!ATTLIST index
  id ID #REQUIRED
  xmlns CDATA #FIXED %ESBK.xmlns;
  version CDATA #FIXED '5.2'
  xmlns:ce CDATA #FIXED %ESCE.xmlns;
  xmlns:xlink CDATA #FIXED %XLINK.xmlns;
  xml:lang %language; 'en'
  role CDATA #IMPLIED
  docsubtype %docsubtype; #FIXED "idx">
```

### Model (Book DTD 5.3.0)

```
<!ELEMENT index ( info, ce:label?, ce:title?,
  ce:index* )>
<!ATTLIST index
  xmlns CDATA #FIXED %ES.xmlns;
  version CDATA #FIXED '5.3'
  xmlns:ce CDATA #FIXED %ESCE.xmlns;
  xmlns:xlink CDATA #FIXED %XLINK.xmlns;
  xml:lang %iso639; 'en'
  id ID #REQUIRED
  role CDATA #IMPLIED
  docsubtype %docsubtype; #FIXED "idx">
```

## Description

The element [index](#) is used to tag indices of terms which usually appear in a book's back matter.

## Usage

The [index](#) element will always appear as a top-level element, with its own DOCTYPE declaration and PUBLIC identifier appearing at the top of the XML file. An [index](#) gets called into the book's hub file by a [ce:include-item](#) element.

Content for [index](#) consists of required [info](#), followed by optional [ce:label](#), optional [ce:title](#), followed by optional/repeatable [ce:index](#) elements, followed by optional/repeatable [ce:bibliography](#) and/or [ce:further-reading](#) elements.

Multiple indices (e.g. Subject Index, Author Index, etc.) should be handled as separate `index` files, called into the book's hub file with separate `ce:include-item` elements. `Role="subject"` should be used to differentiate the subject index from any other indices.

Each `index` should be organized according to the following conventions:

- One `ce:index` element which encapsulates the complete index.
- Each `ce:index` element would contain multiple `ce:index-sec` elements, one for each letter of the alphabet.
- If the terms are separated by alphas that appear in the hardcopy, the `ce:section-title`, child of `ce:index-sec`, should contain the letter of the alphabet for each index section.

Due to their large size, it is envisioned that large index files will be developed in smaller pieces at book typesetters, then combined into a single, large file prior to delivery.

It is quite common in hardcopy book indices, in an effort to save space (and paper) that the first second-level index term appears on the same line as its parent primary index term. Therefore, this needs to be tagged as in the following example (where `ce:index-heading`, etc., have been left out for clarity):

Swallowing, assessment of  
pediatric variations in

Great care must be taken to ensure that such situations are tagged properly in the following manner:

*XML*

```
<ce:index-entry id="idx824">Swallowing,
  <ce:index-entry id="idx825a">assessment of,</ce:index-entry>
  <ce:index-entry id="idx825b">pediatric variations in,</ce:index-entry>
</ce:index-entry>
```

It has an optional `role`, along with several required attributes:

- `id`
- `xmlns:` `http://www.elsevier.com/xml/book/dtd`
- `version:` 5.3
- `xmlns:ce:` `http://www.elsevier.com/xml/common/dtd`
- `xmlns:xlink:` `http://www.w3.org/1999/xlink`
- `xml:lang:` en (default value)
- `docsubtype:` idx

*XML*

```
<!DOCTYPE index PUBLIC "-//ES//DTD book DTD
 version 5.3.0//EN//XML" "book530.dtd" []>
<index docsubtype="idx" id="index" role="subject">
  <info>
    <ce:pri>B978-0-7216-9204-3.00001-6</ce:pri>
    <ce:isbn>978-0-7216-9204-3</ce:isbn>
    <ce:copyright tpe="full-transfer"
      year="2003">Mosby, Inc.</ce:copyright>
  </info>
  <ce:title>Index</ce:title>
  <ce:index>
    <ce:index-sec>
      <ce:section-title>A</ce:section-title>
      <ce:index-entry>
```

```
    <ce:index-heading>aardvark</ce:index-heading>
    <ce:intra-ref href="...">1</ce:intra-ref>
  </ce:index-entry>
  <ce:index-entry>
    ...
  </ce:index-entry>
  ...
</ce:index-sec>
</ce:index>
</index>
```

## Version history

In Elsevier Book DTD 5.2.0 the optional attribute `role` and optional subelement `ce:label` were added. Subelement `ce:index` was made optional/repeatable to allow for Ultralight delivery of book backfile projects.

In the Elsevier Book DTD 5.3.0 added `ce:bibliography` and/or `ce:further-reading` elements at the end of the content model.

# info

## Declaration

### Model (Book DTD 5.1.0–Book DTD 5.3.0)

```
<!ELEMENT info ( ce:pII, ce:doi?, ce:isbn, ce:issn?,
                 ce:document-thread?, ce:copyright,
                 ce:imprint?, ce:doctopics? )>
```

## Description

The element `info` is a placeholder element for book-level metadata elements.

## Usage

The `info` element contains book-project level metadata for the book item and hub. It duplicates a few items from the metadata transport scheme, but only enough to confirm that the book item and book project match. It contains the metadata of all top-level elements of the Books DTD: `book`, `introduction`, `chapter`, `simple-chapter`, `examination`, `fb-non-chapter`, `glossary`, `bibliography`, and `index`.

Content for the `info` element consists of required `ce:pII`, optional `ce:doi`, required `ce:isbn`, optional `ce:issn`, optional `ce:document-thread`, optional `ce:copyright`, optional `ce:imprint`, and optional `ce:doctopics`.

### XML

```
<info>
  <ce:pII>B978-0-323-01679-7.10003-8</ce:pII>
  <ce:isbn>978-0-323-01679-7</ce:isbn>
  <ce:copyright type="full-transfer"
    year="2003">Elsevier Inc.</ce:copyright>
</info>
```

# introduction

## Declaration

### Model (Book DTD 5.1.0, Book DTD 5.1.1)

```
<!ELEMENT introduction      ( info, ce:floats?, ce:title?,
                             ce:author-group*, ce:sections,
                             ce:bibliography* )>
<!ATTLIST introduction
  id                ID                #REQUIRED
  xmlns             CDATA             #FIXED %ES.xmlns;
  version           CDATA             #FIXED '5.1'
  xmlns:ce          CDATA             #FIXED %ESCE.xmlns;
  xmlns:xlink      CDATA             #FIXED %XLINK.xmlns;
  xml:lang          %language;        'en'
  docsubtype       %docsubtype;      #FIXED "itr">
```

### Model (Book DTD 5.2.0, Book DTD 5.2.1)

```
<!ELEMENT introduction      ( info, ce:floats?, ce:title,
                             ce:author-group*, ce:sections?,
                             ( ce:bibliography | ce:further-
                               reading )* )>
<!ATTLIST introduction
  id                ID                #REQUIRED
  xmlns             CDATA             #FIXED %ESBK.xmlns;
  version           CDATA             #FIXED '5.2'
  xmlns:ce          CDATA             #FIXED %ESCE.xmlns;
  xmlns:xlink      CDATA             #FIXED %XLINK.xmlns;
  xml:lang          %language;        'en'
  role             CDATA             #IMPLIED
  docsubtype       %docsubtype;      #FIXED "itr">
```

### Model (Book DTD 5.3.0)

```
<!ELEMENT introduction      ( info, ce:floats?, ce:title,
                             ce:author-group*, ce:sections?,
                             ( ce:bibliography | ce:further-
                               reading )* )>
<!ATTLIST introduction
  xmlns             CDATA             #FIXED %ES.xmlns;
  version           CDATA             #FIXED '5.3'
  xmlns:ce          CDATA             #FIXED %ESCE.xmlns;
  xmlns:xlink      CDATA             #FIXED %XLINK.xmlns;
  xml:lang          %iso639;         'en'
  id               ID                #REQUIRED
  role             CDATA             #IMPLIED
  docsubtype       %docsubtype;      #FIXED "itr">
```

## Description

The element `introduction` is used to capture introductory material which often appears at the beginning of parts or sections used to divide/introduce chapters by topic within the body of a book.

## Usage

Since [parts](#) and/or [sections](#) often contain their own introductory material, the top-level [introduction](#) element is needed to properly capture this content. It gets called into the book's hub file using the [ce:include-item](#).

The introduction element consists of optional [ce:floats](#), required [ce:title](#), an optional/repeatable [ce:author-group](#), followed by optional [ce:sections](#), followed by optional/repeatable [ce:bibliographys](#) and/or [ce:further-readings](#).

It has an optional [role](#), along with several required attributes:

- [id](#)
- [xmlns](#): <http://www.elsevier.com/xml/book/dtd>
- [version](#): 5.3
- [xmlns:ce](#): <http://www.elsevier.com/xml/common/dtd>
- [xmlns:xlink](#): <http://www.w3.org/1999/xlink>
- [xml:lang](#): en (default value)
- [docsubtype](#): itr

### XML

```
<!DOCTYPE introduction
PUBLIC "-//ES//DTD book DTD version 5.3.0//EN//XML"
"book530.dtd" []>
<introduction id="part1-intro" docsubtype="itr">
  <info>
    <ce:pII>B978-0-323-01679-7.10003-8</ce:pII>
    <ce:ISBN>978-0-323-01679-7</ce:ISBN>
    <ce:copyright type="full-transfer"
      year="2003">Mosby, Inc.</ce:copyright>
  </info>
  <ce:floats>
    ...
  </ce:floats>
  <ce:title>Introduction</ce:title>
  <ce:author-group>
    ...
  </ce:author-group>
  <ce:sections>
    <ce:para>Paragraph of introductory
      text for part or section.</ce:para>
  </ce:sections>
</introduction>
```

## Version history

For Elsevier Book DTD 5.2.0, the subelement [ce:sections](#) was made optional to allow for PreCAP deliveries. The subelement [ce:further-reading](#) was also added for items without linked references.



# line

## Declaration

### Model (Book DTD 5.1.1–Book DTD 5.3.0)

```
<!ELEMENT line ( %richstring.data; )*>
```

## Description

The element [line](#) is used to capture a line of text from a poem.

## Usage

Content for [line](#) consists of [line](#).

```
XML
<line>Roses are red</line>
```

## Version history

This element first appeared in EHS Books DTD 5.1.1.

## See also

See also elements [poem](#) and [stanza](#).

# objectives

## Declaration

### Model (Book DTD 5.1.1–Book DTD 5.3.0)

```
<!ELEMENT objectives          ( ce:section-title?, ce:para+ )>
```

## Description

The element `objectives` is used to capture the objectives of a chapter. This information often appears at the beginning of a book chapter.

## Usage

Content for objectives consists of an optional `ce:section-title`, and required/repeatable `ce:para`.

*XML*

```
<objectives>
  <ce:section-title>Objectives</ce:section-title>
  <ce:para>The objectives for this chapter are for the student to ....</ce:para>
</objectives>
```

## Version history

This element first appeared in EHS Books DTD 5.1.1.

# outline

## Declaration

### Model (Book DTD 5.1.1–Book DTD 5.3.0)

```
<!ELEMENT outline          ( ce:list )>
```

## Description

The element `outline` is used to capture the outline of a chapter. This material often appears at the beginning of a book chapter.

## Usage

Content for outline consists of a required `ce:list`.

*XML*

```
<outline>
  <ce:list>
    <ce:section-title>Chapter Outline</ce:section-title>
    <ce:list-item><ce:para>Introduction</ce:para></ce:list-item>
    <ce:list-item><ce:para>Background</ce:para></ce:list-item>
    ...
  </ce:list>
</outline>
```

## Version history

This element first appeared in EHS Books DTD 5.1.1.

## part

### Declaration

#### Model (Book DTD 5.1.0)

```
<!ELEMENT part ( ce:label, ce:title?, ce:author-group*,
                 introduction?, ( section | ce:include-
                 item | ce:bibliography )+ )>
<!ATTLIST part
            id ID #REQUIRED>
```

#### Model (Book DTD 5.1.1)

```
<!ELEMENT part ( ce:label, ce:title?, ce:author-
                 group*, ( section | ce:include-item |
                 ce:further-reading )+ )>
<!ATTLIST part
            id ID #REQUIRED>
```

#### Model (Book DTD 5.2.0)

```
<!ELEMENT part ( ce:label, ce:title?, ce:author-
                 group*, ( section | ce:include-item |
                 ce:further-reading )+ )>
<!ATTLIST part
            id ID #REQUIRED
            role CDATA #IMPLIED>
```

#### Model (Book DTD 5.2.1)

```
<!ELEMENT part ( ce:label?, ce:title?, ce:author-
                 group*, ( section | ce:include-item |
                 ce:further-reading )+ )>
<!ATTLIST part
            id ID #REQUIRED
            role CDATA #IMPLIED>
```

#### Model (Book DTD 5.3.0)

```
<!ELEMENT part ( ce:label?, ce:title?, ce:author-
                 group*, ( part | section | ce:include-
                 item | ce:further-reading )+ )>
<!ATTLIST part
            id ID #REQUIRED
            role CDATA #IMPLIED>
```

### Description

The element [part](#) is used to capture the hierarchy above chapter and/or section when they occur within an Elsevier book.

### Usage

The element [part](#) is a child of [body](#) and of [volume](#). It is used when a large book is divided into parts in order to organize sections and/or chapters into groups. The element [part](#) appears in the hub file for the book.

The [part](#) elements can sometimes have their own introductions. These should be tagged as [introduction](#) and called into the hub file using [ce:include-item](#).

In very rare cases, `part` elements can sometimes have their own bibliography. These should be tagged as `bibliography` and called into the hub file using `ce:include-item`.

The part element consists of an optional `ce:label`, followed by an optional `ce:title`, an optional/repeatable `ce:author-group`, then a required and repeatable grouping of `parts`, `sections` and/or `ce:include-items` and/or `ce:further-reading`.

It has one required attribute, `id` and one optional attribute, `role`.

*XML*

```
<part id="pA"><ce:label>Part A</ce:label>
  <ce:title>GENERAL ISSUES AND APPROACH TO DISEASE
    IN PRIMARY CARE MEDICINE</title>
  <ce:include-item>
    <ce:pii>B0-323-01679-0/10027-7</ce:pii>
    <ce:title>Introduction</ce:title>
    <ce:pages>
      <ce:first-page>1</ce:first-page>
      <ce:last-page>8</ce:last-page>
    </ce:pages>
  </ce:include-item>
  <section id="s1"><ce:label>Section 1</ce:label>
    <ce:title>Core Issues and Special Groups
      in Primary Care</ce:title>
    <ce:include-item>
      <ce:pii>B0-323-01679-0/10003-4</ce:pii>
      <ce:title>Core Issues in Primary Care</ce:title>
      <ce:pages>
        <ce:first-page>9</ce:first-page>
        <ce:last-page>18</ce:last-page>
      </ce:pages>
    </ce:include-item>
    ...
  </section>
  ...
</part>
```

## Version history

Element `introduction` is a top-level element in EHS Books DTD 5.1.0. Since all top-level items are called into the book hub file with `ce:include-item`, subelement `introduction` was removed in EHS Books DTD 5.1.1. Subelement `ce:bibliography` was replaced by `ce:further-reading`.

In Elsevier Book DTD 5.2.0 the optional attribute `role` was added.

In Elsevier Book DTD 5.2.1 subelement `ce:label` was made optional.

In the Elsevier Book DTD 5.3.0 parts were allowed to recurse (part, child of part) to be able to properly handle MRWs.

## Known bugs, hacks and problems

The `ce:further-reading` is deprecated and should no longer be used. It remains to allow for backward compatibility with earlier versions.

## poem

### Declaration

#### Model (Book DTD 5.1.1–Book DTD 5.2.1)

```
<!ELEMENT poem ( ce:title?, ce:author?, stanza+,
                  ce:source? )>
```

#### Model (Book DTD 5.3.0)

```
<!ELEMENT poem ( ce:title?, ce:author?, stanza+,
                  ce:source? )>
<!ATTLIST poem
  id ID #IMPLIED>
```

### Description

The element [poem](#) is used to capture poetry that sometimes appear at the beginning of some book chapters.

### Usage

Content for poem consists of an optional [ce:title](#), optional [ce:author](#), required/repeatable [stanza](#) and optional [ce:source](#).

It has an optional [id](#), [role](#) and [view](#).

*XML*

```
<poem>
  <ce:title>Roses are Red</ce:title>
  <stanza>
    <line>Roses are red</line>
    <line>violets are blue</line>
    ...
  </stanza>
</poem>
```

### Version history

This element first appeared in EHS Book DTD 5.1.1.

In version 5.3.0, optional ID, ROLE, and VIEW attributes were added.

### See also

See also elements [stanza](#) and [line](#).

## rear

### Declaration

#### Model (Book DTD 5.1.0–Book DTD 5.3.0)

```
<!ELEMENT rear ( rearpart+ )>
```

### Description

The element `rear` is used to capture all of the material that appears in the back matter of Elsevier books.

### Usage

The `rear` element is used to delimit and capture the material that appears in the back matter of Elsevier books. It is used in the book’s hub file and consists of required and repeatable `rearparts`.

Lower-level doctypes — `glossary`, `bibliography`, `index`, and `fb-non-chapter` (appendices) — within the `rear` get called in using `ce:include-item` elements.

Although the DTD does not restrict where lower-level book doctypes get called into the hub file, doctypes other than those listed above should not be called into `rear`.

#### XML

```
<rear>
  <rearpart id="rearpart1">
    <ce:title>Appendices</ce:title>
    <ce:include-item>
      <ce:pii>B0-323-01679-0/10027-7</ce:pii>
      <ce:title>Appendix A</ce:title>
      <ce:pages>
        <ce:first-page>1000</ce:first-page>
        <ce:last-page>1001</ce:last-page>
      </ce:pages>
    </ce:include-item>
    <ce:include-item>
      <ce:pii>B0-323-01679-0/10001-0</ce:pii>
      <ce:title>Appendix B</ce:title>
      <ce:pages>
        <ce:first-page>1002</ce:first-page>
        <ce:last-page>1003</ce:last-page>
      </ce:pages>
    </ce:include-item>
  </rearpart>
  <rearpart id="rearpart2">
    <ce:include-item>
      <ce:pii>B0-323-01679-0/10002-2</ce:pii>
      <ce:title>Glossary</ce:title>
      <ce:pages>
        <ce:first-page>1004</ce:first-page>
        <ce:last-page>1020</ce:last-page>
      </ce:pages>
    </ce:include-item>
  </rearpart>
</rear>
```

```
</ce:include-item>
<ce:include-item>
  <ce:pii>B0-323-01679-0/10003-4</ce:pii>
  <ce:title>Index</ce:title>
  <ce:pages>
    <ce:first-page>1021</ce:first-page>
    <ce:last-page>1099</ce:last-page>
  </ce:pages>
</ce:include-item>
</rearpart>
</rear>
```



## rearpart

### Declaration

#### Model (Book DTD 5.1.0, Book DTD 5.1.1)

```
<!ELEMENT rearpart          ( ce:label?, ce:title?, ce:include-
                             item+ )>
<!ATTLIST rearpart
      id                ID                #REQUIRED>
```

#### Model (Book DTD 5.2.0–Book DTD 5.3.0)

```
<!ELEMENT rearpart          ( ce:label?, ce:title?, ce:author-
                             group*, ce:include-item+ )>
<!ATTLIST rearpart
      id                ID                #REQUIRED
      role              CDATA           #IMPLIED>
```

### Description

The element `rearpart` is used to provide organizational divisions to material (usually appendices) that appears in the back matter of Elsevier books.

### Usage

The `rearpart` element is usually used to give named or numbered divisions to material that appears within the back matter of Elsevier Health Science books, usually appendices. If the rear is not divided into parts, then there will only be one `rearpart`. The element appears in the book's hub file.

It consists of an optional `ce:label`, optional `ce:title`, an optional/repeatable `ce:author-group`, then one or more `ce:include-items`.

It has one required attribute, `id` and one optional attribute, `role`.

*XML*

```
<rearpart id="rearpart1">
  <ce:label>I</ce:label>
  <ce:title>Graphical Appendices</ce:title>
  <ce:include-item>
    <ce:pII>B0-323-01679-0/10027-7</ce:pII>
    <ce:title>Appendix A</ce:title>
    <ce:pages>
      <ce:first-page>1000</ce:first-page>
      <ce:last-page>1001</ce:last-page>
    </ce:pages>
  </ce:include-item>
  <ce:include-item>
    <ce:pII>B0-323-01679-0/10001-0</ce:pII>
    <ce:title>Appendix B</ce:title>
    <ce:pages>
      <ce:first-page>1002</ce:first-page>
      <ce:last-page>1003</ce:last-page>
    </ce:pages>
  </ce:include-item>
```

```
</rearpart>
<rearpart id="rearpart2">
  <ce:title>Tabular Appendices</ce:title>
  <ce:include-item>
    <ce:pii>B0-323-01679-0/10002-2</ce:pii>
    <ce:title>Appendix C</ce:title>
    <ce:pages>
      <ce:first-page>1004</ce:first-page>
      <ce:last-page>1005</ce:last-page>
    </ce:pages>
  </ce:include-item>
  <ce:include-item>
    <ce:pii>B0-323-01679-0/10003-4</ce:pii>
    <ce:title>Appendix D</ce:title>
    <ce:pages>
      <ce:first-page>1006</ce:first-page>
      <ce:last-page>1007</ce:last-page>
    </ce:pages>
  </ce:include-item>
</rearpart>
```

## Version history

The optional/repeatable subelement `ce:author-group` and optional attribute `role` were both added in Elsevier Book DTD 5.2.0.

## section

### Declaration

#### Model (Book DTD 5.1.0)

```
<!ELEMENT section ( ce:label, ce:title?, ce:author-group*,
                    introduction?, ( ce:include-item |
                    ce:bibliography )+ )>
<!ATTLIST section
    id ID #REQUIRED>
```

#### Model (Book DTD 5.1.1)

```
<!ELEMENT section ( ce:label, ce:title?, ce:author-group*,
                    ( ce:include-item | ce:further-
                    reading )+ )>
<!ATTLIST section
    id ID #REQUIRED>
```

#### Model (Book DTD 5.2.0)

```
<!ELEMENT section ( ce:label, ce:title?, ce:author-group*,
                    ( ce:include-item | ce:further-
                    reading )+ )>
<!ATTLIST section
    id ID #REQUIRED
    role CDATA #IMPLIED>
```

#### Model (Book DTD 5.2.1, Book DTD 5.3.0)

```
<!ELEMENT section ( ce:label?, ce:title?, ce:author-
                    group*, ( ce:include-item |
                    ce:further-reading )+ )>
<!ATTLIST section
    id ID #REQUIRED
    role CDATA #IMPLIED>
```

### Description

The element `section` is used to capture the hierarchy above chapter if/when they occur within Elsevier books.

### Usage

A `section` is used in large books to organize `ce:include-items` (chapters or examinations) into groups. It is a child of `body` and `volume` and/or `part` should not be confused with the common element `ce:section` that is used for subdivisions within items such as chapters.

A `section` can sometimes have its own introduction. These should be tagged as `introduction` and called into the hub file using `ce:include-item`.

In very rare cases, `section` elements can sometimes have their own bibliography. These should be tagged as `bibliography` and called into the hub file using `ce:include-item`.

The `section` element consists of an optional `ce:label`, optional `ce:title`, an optional/repeatable `ce:author-group`, then one or more groupings of `ce:include-items` and/or `ce:sections` and/or `ce:further-reading`.

It has one required attribute, `id` and one optional attribute, `role`.

*XML*

```

<section id="s1"><ce:label>Section 1</ce:label>
  <ce:title>Core Issues and Special Groups
    in Primary Care</ce:title>
  <ce:include-item>
    <ce:pri>B0-323-01679-0/10003-4</ce:pri>
    <ce:title>Core Issues in Primary Care</ce:title>
    <ce:pages>
      <ce:first-page>1</ce:first-page>
      <ce:last-page>8</ce:last-page>
    </ce:pages>
  </ce:include-item>
  <ce:include-item>
    <ce:pri>B0-323-01679-0/10027-7</ce:pri>
    <ce:title>Special Groups in Primary Care</ce:title>
    <ce:pages>
      <ce:first-page>9</ce:first-page>
      <ce:last-page>18</ce:last-page>
    </ce:pages>
  </ce:include-item>
  ...
</section>

```

**Version history**

Element [introduction](#) is a top-level element in EHS Books DTD 5.1.0. Since all top-level items are called into the book hub file with [ce:include-item](#), subelement [introduction](#) was removed. Subelement [ce:bibliography](#) was replaced by [ce:further-reading](#).

In Elsevier Book DTD 5.2.0 the optional attribute [role](#) was added.

In Elsevier Book DTD 5.2.1 subelement [ce:label](#) was made optional.

**Known bugs, hacks and problems**

The [ce:further-reading](#) is deprecated and should no longer be used. It remains to allow for backward compatibility with earlier versions.

## simple-chapter

### Declaration

#### Model (Book DTD 5.2.0)

```
<!ELEMENT simple-chapter ( ce:footnote*, info, ce:floats?,
ce:label, ce:title, ce:subtitle?,
ce:author-group*, ce:displayed-
quote?, poem?, outline?, objectives?,
ce:nomenclature?, ce:acknowledgment?,
ce:intro?, ( ce:sections | subchapter
| exam )*, ( ( ce:bibliography |
ce:further-reading )+, ( ce:section |
exam )* )? )>

<!ATTLIST simple-chapter
  id ID #REQUIRED
  xmlns CDATA #FIXED %ESBK.xmlns;
  version CDATA #FIXED '5.2'
  xmlns:ce CDATA #FIXED %ESCE.xmlns;
  xmlns:xlink CDATA #FIXED %XLINK.xmlns;
  xml:lang %language; 'en'
  role CDATA #IMPLIED
  docsubtype %docsubtype; #FIXED "scp">
```

#### Model (Book DTD 5.2.1)

```
<!ELEMENT simple-chapter ( ce:footnote*, info, ce:floats?,
ce:label?, ce:title, ce:subtitle?,
ce:author-group*, ce:displayed-
quote?, poem?, outline?, objectives?,
ce:nomenclature?, ce:acknowledgment?,
ce:intro?, ( ce:sections | subchapter
| exam )*, ( ( ce:bibliography |
ce:further-reading )+, ( ce:section |
exam )* )? )>

<!ATTLIST simple-chapter
  id ID #REQUIRED
  xmlns CDATA #FIXED %ESBK.xmlns;
  version CDATA #FIXED '5.2'
  xmlns:ce CDATA #FIXED %ESCE.xmlns;
  xmlns:xlink CDATA #FIXED %XLINK.xmlns;
  xml:lang %language; 'en'
  role CDATA #IMPLIED
  docsubtype %docsubtype; #FIXED "scp">
```

#### Model (Book DTD 5.3.0)

```
<!ELEMENT simple-chapter ( ce:footnote*, info, ce:floats?,
ce:label?, ce:title, ce:subtitle?,
ce:author-group*, ce:miscellaneous?,
ce:abstract*, ce:displayed-quote?,
poem?, outline?, objectives?,
ce:nomenclature?, ce:acknowledgment?,
ce:intro?, ( ce:sections | subchapter
| exam )*, ( ( ce:bibliography |
ce:further-reading )+, ( ce:section |
exam )* )? )>

<!ATTLIST simple-chapter
```

xmlns	CDATA	#FIXED %ES.xmlns;
version	CDATA	#FIXED '5.3'
xmlns:ce	CDATA	#FIXED %ESCE.xmlns;
xmlns:xlink	CDATA	#FIXED %XLINK.xmlns;
xml:lang	<a href="#">%iso639;</a>	'en'
id	ID	#REQUIRED
role	CDATA	#IMPLIED
docsubtype	<a href="#">%docsubtype;</a>	#FIXED "scp">

## Description

The element [simple-chapter](#) is used to capture book chapters as individual XML files, but only in a PreCAP backfile conversion project.

## Usage

The [simple-chapter](#) element is used to capture all the material that appears within a book chapter. There is a PUBLIC identifier and a DOCTYPE declaration for simple-chapter, and individual chapter files get called into the book's hub file using the [ce:include-item](#) element.

Although the DTD does not restrict where lower-level book doctypes get called into the hub file, the intent is for [simple-chapter](#) only to be called into [body](#), not in [front](#) or [rear](#).

Content for simple-chapter consists of an optional/repeatable [ce:footnote](#), a required [info](#) and the optional [ce:floats](#) container. The chapter begins with the (optional) [ce:label](#), containing the name of the chapter ("Chapter 4"), the chapter title, captured by use of the [ce:title](#), and optional and repeatable [ce:author-group](#) containing authors and their affiliations. Followed by optional [ce:miscellaneous](#), optional/repeatable [ce:abstract](#). The optional subelements [ce:displayed-quote](#), [poem](#), [outline](#), [objectives](#), and [ce:nomenclature](#) also belong to the "head" of the chapter, followed by an optional [ce:acknowledgment](#). An introduction or summary is contained in the optional [ce:intro](#).

The main body of the chapter consists of a optional/repeatable sequence of [ce:sections](#), [subchapter](#) and/or [exam](#) elements, followed by optional/repeatable [ce:bibliography](#) and/or [ce:further-reading](#), possibly followed by more [ce:sections](#) and/or [exams](#).

It has an optional [role](#), along with several required attributes:

- [id](#)
- [xmlns](#): <http://www.elsevier.com/xml/book/dtd>
- [version](#): 5.3
- [xmlns:ce](#): <http://www.elsevier.com/xml/common/dtd>
- [xmlns:xlink](#): <http://www.w3.org/1999/xlink>
- [xml:lang](#): en (default value)
- [docsubtype](#): scp

### XML

```
<!DOCTYPE simple-chapter
PUBLIC "-//ES//DTD book DTD version 5.3.0//EN//XML"
"book530.dtd" []>
<simple-chapter id="ch1">
  <info>
    <ce:pII>B978-0-323-01679-7.10003-8</ce:pII>
```

```
<ce:isbn>978-0-323-01679-7</ce:isbn>
<ce:copyright type="full-transfer"
  year="2003">Mosby, Inc.</ce:copyright>
</info>
<ce:bibliography>
  ...
</ce:bibliography>
</simple-chapter>
```

## Version history

This top element was added in Elsevier Book DTD 5.2.0 to allow for deliveries of book backfile projects.

In Elsevier Book DTD 5.2.1 subelement [ce:label](#) was made optional.

In Elsevier Book DTD 5.3.0 added optional [ce:miscellaneous](#), and optional/repeatable [ce:abstract](#).

## stanza

### Declaration

#### Model (Book DTD 5.1.1–Book DTD 5.3.0)

```
<!ELEMENT stanza ( line+ )>
```

### Description

The element [stanza](#) is used to capture a block of lines from a poem.

### Usage

Content for stanza consists of required/repeatable [line](#).

*XML*

```
<stanza>
  <line>Roses are red</line>
  <line>violets are blue</line>
  ...
</stanza>
```

### Version history

This element first appeared in EHS Books DTD 5.1.1.

### See also

See also elements [poem](#) and [line](#).



## subchapter

### Declaration

#### Model (Book DTD 5.1.0)

```
<!ELEMENT subchapter ( ce:label?, ce:title, ce:author-group*,
                        ce:displayed-quote?, ce:nomenclature?,
                        ce:intro?, ( ce:section | subchapter
                        | exam )+, ( ce:bibliography |
                        ce:further-reading )+, ( ce:section |
                        exam )* )>

<!ATTLIST subchapter
            id ID #REQUIRED>
```

#### Model (Book DTD 5.1.1)

```
<!ELEMENT subchapter ( ce:label?, ce:title, ce:author-group*,
                        ce:displayed-quote?, ce:nomenclature?,
                        ce:intro?, ( ce:sections | subchapter
                        | exam )+, ( ce:bibliography |
                        ce:further-reading )+, ( ce:section |
                        exam )* )>

<!ATTLIST subchapter
            id ID #REQUIRED>
```

#### Model (Book DTD 5.2.0, Book DTD 5.2.1)

```
<!ELEMENT subchapter ( ce:footnote*, ce:label?, ce:title,
                        ce:author-group*, ce:displayed-quote?,
                        ce:nomenclature?, ce:acknowledgment?,
                        ce:intro?, ( ce:sections | subchapter
                        | exam )+, ( ce:bibliography |
                        ce:further-reading )+, ( ce:section |
                        exam )* )>

<!ATTLIST subchapter
            id ID #REQUIRED
            role CDATA #IMPLIED>
```

#### Model (Book DTD 5.3.0)

```
<!ELEMENT subchapter ( ce:footnote*, ce:label?, ce:title,
                        ce:author-group*, ce:displayed-quote?,
                        ce:nomenclature?, ce:acknowledgment?,
                        ce:intro?, ( ce:sections | subchapter
                        | exam )+, ( ce:bibliography |
                        ce:further-reading )+, ( ce:section |
                        exam )* )>

<!ATTLIST subchapter
            id ID #REQUIRED
            role CDATA #IMPLIED>
```

### Description

The element `subchapter` is used to capture large portions of hierarchy that occur within book chapters.

## Usage

Quite frequently, book chapters are so large, that the subchapter element is needed to capture the complex hierarchy that occurs within them. Such divisions of chapters are often written by separate authors and will often contain their own references. For this DTD, the hierarchy below chapter that has its own author(s) and/or references should be tagged as a [subchapter](#). Hierarchy below chapter which does not have its own author(s) or references should be done as [ce:sections](#).

Content for the [subchapter](#) element is similar to the structure of its parent, [chapter](#), and consists of an optional/repeatable [ce:footnote](#), an optional [ce:label](#), a required [ce:title](#), optional and repeatable [ce:author-group](#). Followed by optional [ce:date-received](#), optional/repeatable [ce:date-revised](#), optional [ce:date-accepted](#), and optional/repeatable [ce:keywords](#), optional [ce:displayed-quote](#) and [ce:nomenclature](#), followed by an optional [ce:acknowledgment](#), optional introductory text in [ce:intro](#), followed by required/repeatable [ce:sections](#) and/or nested [subchapters](#) and/or [exams](#), followed by optional/repeatable [ce:bibliography](#) and/or [ce:further-reading](#), followed by optional/repeatable [ce:sections](#) and/or [exams](#).

It has one required attribute, [id](#) and optional [role](#) and optional [view](#).

### XML

```
<subchapter id="sc11">
  <ce:label>1.1</ce:label>
  <ce:title>Summary of Primary Care Today</ce:title>
  <ce:author-group>
    ...
  </ce:author-group>
  <ce:intro>
    <ce:para>Text of introductory paragraph...</ce:para>
  </ce:intro>
  <ce:section>
    <ce:title>Opening section title</ce:title>
    <ce:para>Text of first paragraph...</ce:para>
    <ce:para>Text of second paragraph...</ce:para>
  </ce:section>
  <ce:bibliography>
    ...
  </ce:bibliography>
</subchapter>
```

## Version history

In EHS Books DTD 5.1.1 the occurrence indicator for [ce:author-group](#) changed from ? to \*. Element [examination](#) was replaced by [exam](#) and the [docsubtype](#) attribute was added. Element [ce:section](#) was changed to [ce:sections](#) to allow subchapters to begin with regular paragraphs.

In Elsevier Book DTD 5.2.0, an optional/repeatable [ce:footnote](#) was added to the beginning of the content model for [subchapter](#). The optional attribute [role](#) was also added.

In Elsevier Book DTD 5.3.0 [ce:title](#) Reference end-notes were made optional.

## top

### Declaration

#### Model (Book DTD 5.1.0)

```
<!ELEMENT top ( %titles;, ce:edition, ce:copyright-
                line, ce:editors?, ce:author-group*,
                ce:dedication?, ce:sections )>
```

#### Model (Book DTD 5.1.1)

```
<!ELEMENT top ( %titles;, ce:edition, ce:copyright-
                line, ce:editors?, ce:author-group*,
                ce:dedication*, ce:sections )>
```

#### Model (Book DTD 5.2.0)

```
<!ELEMENT top ( %titles;, ce:edition, ce:copyright-
                line, cover-image?, ce:editors*,
                ce:author-group*, dedication*,
                ce:sections )>
```

#### Model (Book DTD 5.2.1, Book DTD 5.3.0)

```
<!ELEMENT top ( %titles;, ce:edition?, ce:copyright-
                line, cover-image?, ce:editors*,
                ce:author-group*, dedication*,
                ce:sections )>
```

### Description

The element `top` is a another placeholder element for book-level metadata elements.

### Usage

The info element contains book-project level metadata for the book item. It also contains material intended to render the following non-item material: title page, copyright page, and dedication (if present).

Content for the `top` element consists of required `ce:title`, optional `ce:subtitle`, optional/repeatable combination of required `ce:alt-title`, optional `ce:alt-subtitle`, followed by optional `ce:edition`, required `ce:copyright-line`, optional `cover-image`, optional `ce:editors`, optional/repeatable `ce:author-group`, optional/repeatable `dedication`, and required `ce:sections`.

*XML*

```
<top>
  <ce:title>Mosby's Clinical Nursing</ce:title>
  <ce:edition>5th Edition</ce:edition>
  <ce:editors>
    <ce:author-group>...</ce:author-group>
    <ce:author-group>...</ce:author-group>
  </ce:editors>
  <ce:copyright-line>Copyright &copy; 2002
    Mosby, Inc.</ce:copyright-line>
  <cover-image>...</cover-image>
  <ce:sections>
```

```
<ce:para>Previous editions copyrighted ...</ce:para>
<ce:para>All rights reserved. No part of this publication
    may be reproduced...</ce:para>
</ce:sections>
</top>
```

## Version history

In EHS Books DTD 5.1.1 the occurrence indicator for `ce:dedication` changed from ? to \*.

In the Elsevier Book DTD 5.2.0 the optional `cover-image` was added while `ce:dedication` was replaced by `dedication` to properly allow for book dedications that tend to be more elaborate than articles.

In the Elsevier Book DTD 5.2.1 the element `ce:edition` was made optional.

Due to changes over time, the `top` has become largely empty. Author dedications and the copyright page are now both now delivered as items within `front`. Refer to the CAP guides for specific detailed guidance.

## volume

### Declaration

#### Model (Book DTD 5.1.0, Book DTD 5.1.1)

```
<!ELEMENT volume          ( ce:label, ( part | section |
                             ce:include-item )+ )>
<!ATTLIST volume
  id                ID                #REQUIRED>
```

#### Model (Book DTD 5.2.0)

```
<!ELEMENT volume          ( ce:label, ce:title?, ce:author-group*,
                             ( part | section | ce:include-
                             item )+ )>
<!ATTLIST volume
  id                ID                #REQUIRED
  role              CDATA            #IMPLIED>
```

#### Model (Book DTD 5.2.1, Book DTD 5.3.0)

```
<!ELEMENT volume          ( ce:label?, ce:title?, ce:author-
                             group*, ( part | section | ce:include-
                             item )+ )>
<!ATTLIST volume
  id                ID                #REQUIRED
  role              CDATA            #IMPLIED>
```

### Description

Unlike journals, where a volume is a collection of journal issues, volumes in Elsevier books are usually only due to limitations of binding. In rare cases, they can also be used to delimit topical hierarchy as well. The element `volume` is used to capture material that appears between separately bound volumes of a multi-volume book if they occur within Elsevier books.

### Usage

The volume element, a child of `body`, is used to delimit and capture the material that appears between each separately bound volume if/when they occur. It should be noted that only the `ce:include-items` and hierarchy above them (material within `body`) appears within volume. This differs from many hardcopy multi-volume books where front and back matter gets repeated in each separately bound volume.

The `volume` element consists of an optional `ce:label` (often a Roman numeral), an optional `ce:title`, an optional/repeatable `ce:author-group`, followed by required/repeatable `parts` and/or `sections` and/or `ce:include-items`.

It has one required attribute, `id` and one optional attribute, `role`.

*XML*

```
<volume id="vI">
  <ce:label>Volume I</ce:label>
  <part id="pA"><ce:label>Part A</ce:label>
    <ce:title>GENERAL ISSUES AND APPROACH TO DISEASE
      IN PRIMARY CARE MEDICINE</title>
```

```

<ce:include-item>
  <ce:pii>B0-323-01679-0/10027-7</ce:pii>
  <ce:title>Introduction</ce:title>
  <ce:pages>
    <ce:first-page>1</ce:first-page>
    <ce:last-page>8</ce:last-page>
  </ce:pages>
</ce:include-item>
<section id="s1"><ce:label>Section 1</ce:label>
  <ce:title>Core Issues and Special Groups
  in Primary Care</ce:title>
  <ce:include-item>
    <ce:pii>B0-323-01679-0/10003-4</ce:pii>
    <ce:title>Core Issues in Primary Care</ce:title>
    <ce:pages>
      <ce:first-page>9</ce:first-page>
      <ce:last-page>18</ce:last-page>
    </ce:pages>
  </ce:include-item>
  ...
</section>
...
</part>
<part id="pB">
  <ce:label>Part B</ce:label>
  <ce:title>Title of Second Part</title>
  ...
</part>
</volume>

```

## Version history

In Elsevier Book DTD 5.2.0 optional `ce:title`, optional/repeatable `ce:author-group`, and optional attribute `role` were added.

In Elsevier Book DTD 5.2.1 subelement `ce:label` was made optional.

## Chapter 6

# The Common Element Pool

The common element pool (CEP), a phrase coined by Jabin White, contains elements that are common to all or some of the Elsevier DTDs. The common elements are subdivided in five namespaces:

- the “core” common element pool, whose elements are described in Chapter 7,
- the elements for structured bibliographic references, described in Chapter 8,
- the MathML elements, with Elsevier modifications, described in Chapter 9,
- the CALS table elements and the Extended CALS table elements, both described in Chapter 10.

This chapter (Chapter 6) contains general notions regarding the common element pool and the XML files that are structured according to the DTDs that use it. When individual elements are mentioned, their details can be found in the above-mentioned chapters.

Observe that the common element pool is used by several DTDs and contains elements shared by several of these DTDs, but not necessarily all. For instance, the JA DTD does not contain elements such as `ce:isbn`, `ce:index`, `ce:index-flag` or `ce:intra-ref`. In some cases this is accomplished by parametrization using parameter entities.

## Versions of the common element pool

This section describes the changes in the common element pool (CEP) since its first release as version 1.0.0. It also lists which DTDs make use of that particular version of the common element pool.

### CEP 1.1.0

- The following elements were added: `ce:isbn`, `ce:issn`, `ce:include-item`, `ce:pages`, `ce:first-page`, `ce:last-page`, `ce:copyright-line`, `ce:index-flag`, `ce:index-flag-term`, `ce:index-flag-see`, `ce:index-flag-see-also`.
- The following parameter entities were added: `%common-altimg.att;`, `%common-view.att;`, `%tbl.tgroup.att;`.
- Parameter entity `%titles;` was renamed to `%sb.titles;` and a new parameter entity `%titles;` was introduced.
- Element `ce:article-thread` was replaced by `ce:document-thread` and element `ce:refers-to-article` was replaced by `ce:refers-to-document`.
- Element `sb:comment`'s model was changed to allow for more content.
- Elements `ce:glossary` and `ce:index` now contain `ce:intro` in their models.
- Element `ce:textbox-tail` now contains `ce:glossary` and `ce:biography` in its model.
- Element `ce:author` now has an attribute `author-id`.
- Attribute `xml:lang` of `ce:abstract` now takes its values in `%iso639;`.
- The following elements now have an attribute `view`: `ce:appendices`, `ce:bibliography`, `ce:further-reading`, `ce:glossary`, `ce:index`, `ce:biography`, `ce:exam-reference`, `ce:exam-questions`, `ce:exam-answers`.
- The following elements now use `%sb.titles;` instead of `%titles;`: `sb:contribution`, `sb:series`, `sb:book`, `sb:edited-book`.

### CEP 1.1.0 patch level 1

The journal article (JA) DTD 5.0.1 makes use of this version of the CEP.

- The model of element `ce:e-component` was repaired to allow for multiple nested `ce:link` and `ce:e-component` subelements instead of just one.

### CEP 1.1.0.1

The journal article (JA) DTD 5.0.2 makes use of this version of the CEP.

- New parameter entity `%common-reqaltimg.att;` was added.
- New elements `ce:markers` and `ce:marker` were added.

### CEP 1.1.1

- Element `ce:imprint` was added.
- The notation declarations were extended with system identifiers.
- Value `it` was added to parameter entity `%language;`.
- The titles in element `ce:include-item` were made optional.



**CEP 1.1.2**

The EHS Books DTD 5.1.0 makes use of this version of the CEP.

- The following elements were added: `ce:edition`, `ce:editors`, `ce:br`.
- The following parameter entities were added: `%copyright;`, `%external-file.att;`, `%tbl.colspec.att;`, `%tbl.row.att;`.
- Parameter entity `%size-info.att;` was removed.
- Element `ce:br` was added to parameter entity `%cell.data;`.
- The following elements now have parameter entity `%cross-ref;` instead of element `ce:cross-ref` in their model: `ce:collaboration`, `ce:author`.
- The following elements now have parameter entity `%copyright;` instead of element `ce:copyright` in their model: `ce:figure`, `ce:textbox`, `ce:e-component`.
- The attribute list of `ce:link` was changed; it now consists of attributes `id` and `locator`.
- Element `ce:caption` now has an attribute list with attributes `role` and `xml:lang`.
- The models of elements `ce:e-component`, `ce:alt-e-component`, `ce:figure` and `ce:textbox` were changed to allow for more than one `ce:caption`.
- The model of parameter entity `%tbl.titles;` was changed to allow for more than one `ce:caption;` it now also contains parameter entity `%copyright;`.

**CEP 1.1.3**

The serial issue DTD 5.1.0, the EHS Books DTD 5.1.1 and the Elsevier Book DTDs 5.2.0 and 5.2.1 make use of this version of the CEP.

- The following elements were added: `ce:source`, `ce:reader-see`.
- Parameter entity `%see;` was introduced.
- Element `ce:index-entry` now uses element `ce:reader-see`, and parameter entity `%see;` instead of element `ce:see`.
- Element `ce:source` was added to the models of elements `ce:figure`, `ce:textbox`, `ce:e-component`, and to the model of parameter entity `%tbl.titles;`.

**CEP 1.1.4**

This CEP was intended to be used by the major reference works (MRW) DTD 5.0.0.

- New parameter entities `%glossary-entry-refs;` and `%index-entry-refs;` were added.
- Element `ce:indexed-name` was added to the models of elements `ce:glossary-entry` and `ce:index-entry`.
- Element `ce:reader-see` was added to the model of element `ce:glossary-entry`.
- New parameter entity `%common-reqalting.att;` was added.
- New elements `ce:markers` and `ce:marker` were added.

**CEP 1.1.5**

The journal article (JA) DTD 5.1.0 makes use of this version of the CEP.

- New parameter entity `%text-objects;` was added to the model of parameter entity `%note.data;`.
- Parameter entity `%language;` was removed and replaced by parameter entity `%iso639;` in the models of elements `ce:ce:alt-title`, `ce:alt-subtitle` and `ce:keyword`.
- Attribute `role` was added to the model of element `ce:e-component`.
- New elements `ce:grant-sponsor` and `ce:grant-number` were added.

**CEP 1.1.6**

The Elsevier Book DTD 5.3.0 makes use of this version of the CEP.

- Attributes `id`, `role` and `view` were added to the model of numerous elements.
- Element `ce:section-title` was made optional in the models of elements `ce:further-reading`, `ce:glossary` and `ce:index`.
- Element `ce:text` was added to the model of element `ce:author-group`.

## Cross-references and the ce:label element

Cross-referencing with the one-to-many `ce:cross-refs` is complicated. The content of that element is popularly thought of as the text to click on — but there is only one text to click on while there are multiple destinations. An online rendering of the document will want to present the user with a list of possible destinations. In this section, we assume that that list is in the form of a drop-down menu with destinations; in practice applications have often chosen to present the destinations inline. (For more details about that, see `ce:cross-refs`.)

The element `ce:cross-refs` must have more than one destination. The element `ce:cross-ref` is used for a simple link. Each destination is a valid `id` in the document. Elements may have `ids` whether or not they are being referred to.

The structure of the document must guarantee that such a drop-down list of destinations can be created. A crucial role is played by the `ce:label` elements of the destinations, because their content is used to fabricate the drop-down list. (In fact, this is a simplification, because not all elements possess a `ce:label`, but it is a concept worth remembering; more precise details are found below.)

The elements `ce:intra-refs` and `ce:inter-refs` are different. These elements conform to the XLink standard, and contain the names of the destinations in their subelements `ce:intra-ref-title` and `ce:inter-ref-title`. In the *Output DTD* each `ce:cross-ref` can be converted to `ce:intra-ref`.

In order to make one-to-many links work it is wrong, and even impossible, to analyze the *content* of the `ce:cross-refs`. The application should rely on the XML structure. To this end, there is a collection of *rules* which are described in this section. Roughly, the rules subscribe to the “drop-down menu principle”, which states that the destinations of the one-to-many link are the `ce:label` elements of the destination objects.

As an example, consider a document containing displayed equations Eqs. (2)–(14). The equations (4)–(13) are supplied on a graphic and they are shown in Scheme 6 (i.e., not captured in XML); the other equations are captured in XML. The following figure illustrates what happens if reference is made in the text to “Eqs. (2)–(14)”.

```
see <ce:cross-refs refid="fd2 fd3 sch6 fd14">Eqs. (2)&ndash;(14)</ce:cross-refs>
```

see Eqs. (2)–(14)

(2)	→	<ce:formula id="fd2"><ce:label>(2)</ce:label>
(3)	→	<ce:formula id="fd3"><ce:label>(3)</ce:label>
Scheme 6	→	<ce:figure id="sch6"><ce:label>Scheme 6</ce:label>
(14)	→	<ce:formula id="fd14"><ce:label>(14)</ce:label>

The “drop-down” menu, indicated above by the box underneath the “Eqs. (2)–(14)” (the text to click on), contains the `ce:label` elements of the four destinations, not all of which are displayed equations.

The rules for cross-referencing depend on the element. For each situation, a suggested “drop-down menu item” text is given below. In some cases, it is not even allowed to use `ce:cross-refs` to certain destinations.

Even though the XML validation checks the validity of the rules, rendering applications should be able to deal with exceptions and error situations. The `id` itself, for instance, could be used as a last resort.

### No `ce:cross-refs` allowed

It is not allowed to use the one-to-many `ce:cross-refs` to the following destinations:

`ce:abstract`, `ce:affiliation`, `ce:anchor`, `ce:acknowledgment`, `ce:author`, `ce:biography`, `ce:collaboration`, `ce:def-term`, `ce:displayed-quote`, `ce:glossary-entry`, `ce:index-entry`, `ce:index-flag`, `ce:inter-ref`, `ce:inter-refs-text`, `ce:intra-ref`, `ce:intra-refs-text`, `ce:link`, `ce:note-para`, `ce:para`, `ce:section-title`, `ce:simple-para`, `ce:text`, `ce:textfn`, `ce:textref`.

It is, of course, allowed to use `ce:cross-ref`.

### Mandatory `ce:label`

If the following elements are the target of a `ce:cross-refs`, they must have a `ce:label` element:

`ce:bib-reference` (\*), `ce:correspondence` (\*), `ce:e-component`, `ce:enunciation` (\*), `ce:figure`, `ce:footnote` (\*), `ce:list-item`, `ce:table`, `ce:table-footnote` (\*), `ce:textbox`.

(\*) Ensured by the DTD. The suggested “drop-down” text is the content of `ce:label`.

### Mandatory `ce:section-title`

If the following elements are the target of a `ce:cross-refs` they must have a `ce:section-title` element:

`ce:bibliography` (\*), `ce:bibliography-sec`, `ce:exam-answers`, `ce:exam-questions`, `ce:further-reading` (\*), `ce:further-reading-sec`, `ce:glossary` (\*), `ce:glossary-sec`, `ce:index` (\*), `ce:index-sec`.

(\*) Ensured by the DTD. The suggested “drop-down” text is the content of the `ce:section-title`.

### Mandatory `ce:label` or `ce:section-title`

If the following elements are the target of a `ce:cross-refs` (plural), they must have a `ce:label` and/or a `ce:section-title` element:

`ce:def-list`, `ce:list`, `ce:section`.

The suggested “drop-down” text is the concatenation of the `ce:label` and the `ce:section-title`.

### Element `ce:formula`

If the `ce:formula` does not contain nested `ce:formulae`, then it must have a `ce:label` subelement if it is the target of `ce:cross-ref` or `ce:cross-refs`.

If the `ce:formula` has nested `ce:formula` subequations, then the following rules apply.

1. If the top `ce:formula` is the target of a cross-reference (`ce:cross-ref` or `ce:cross-refs`), either it must possess a `ce:label` element itself or all nested `ce:formulae` must possess one.

2. If a nested `ce:formula` is the target of a cross-reference, it must have a `ce:label` element.
3. A `ce:label` may not occur on both the top and the nested level.

The suggested “drop-down menu” item text belonging to an `id` contains the content of the `ce:label` or the `ce:labels` of the sublevel.

### Elements `sb:reference`, `ce:other-ref`

If beside an `sb:reference` the parent `ce:bib-reference` does not contain any other `sb:reference` nor any `ce:other-refs`, then the `sb:reference` may not be the target of a cross-reference. (The reference must be made to the `ce:bib-reference`.)

If beside a `ce:other-ref` the parent `ce:bib-reference` does not contain any other `ce:other-ref` nor any `sb:references`, then the `ce:other-ref` may not be the target of a cross-reference. (The reference must be made to the `ce:bib-reference`.)

Any elements `sb:reference` and `ce:other-ref` that are the target of a cross-reference, must have a `ce:label` subelement.

All bibliographic references within `ce:bibliography` must be referred to from within the document (unless the XML file is of the HEAD-AND-TAIL variety). This means that for each `ce:bib-reference` at least one reference is made to either the `id` of the `ce:bib-reference` (and to zero or more child-`sb:references` and child-`ce:other-refs`) or to the `ids` of all child-`sb:references` and all child-`ce:other-refs`.

The elements `sb:reference` and `ce:other-ref` are “incomplete” cross-reference targets: their `ce:label` element is not meaningful for cross-referencing purposes without the `ce:label` element of their parent. This means that, in a one-to-many link with `sb:reference` and/or `ce:other-ref` elements, the “drop-down menu” (see earlier in this section) should show a combination of the `ce:label` elements of the cross-referenced `sb:reference` or `ce:other-ref` and that of the parent `ce:bib-reference` element.

#### XML

```
<ce:para>...
  Refs. <ce:cross-refs refid="bb2a or3b bib4">[2a,3b,4]</cross-refs>
  ...
<ce:bibliography>...
  <ce:bib-reference id="bib2"><ce:label>[2]</ce:label>
    <sb:reference id="bb2a"><ce:label>(a)</ce:label>...
    <sb:reference id="bb2b"><ce:label>(b)</ce:label>...
  </ce:bib-reference>
  <ce:bib-reference id="bib3"><ce:label>[3]</ce:label>
    <sb:reference id="bb3a"><ce:label>(a)</ce:label>...
    <other-ref id="or3b"><ce:label>(b)</ce:label>...
  </ce:bib-reference>
  <ce:bib-reference id="bib4"><ce:label>[4]</ce:label>...
</ce:bib-reference>
```

*Presentation*

see Refs. [2a,3b,4]

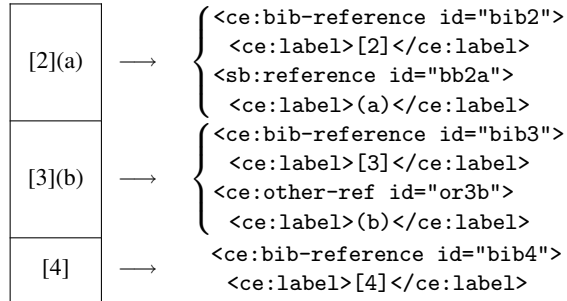

## Text effects

The text effect elements are listed in the parameter entity `%text-effect`; and include the elements `ce:sup`, `ce:inf`, `ce:hsp`, `ce:vsp`, the font-decoration elements `ce:underline`, `ce:cross-out`, as well as the five font-changing elements. The element `ce:br` is also considered to be a text effect element.

The content of the font-changing and font-decoration elements and the text effects `ce:sup` and `ce:inf` is described by the parameter entity `%richstring.data`. They may contain text, but no footnotes, anchors, cross-references and MathML formulae.

### Font-changing and font-decoration elements

The opening tag of a font-changing or font-decoration element changes the properties of the font. The font-decoration elements and most font-changing elements, the *font-style* changing elements, change only one aspect of the current font, but other font-changing elements, the *font-family* changing elements, replace the current font. The closing tag undoes the changes and restores the font properties to the values that were in effect at the opening tag.

The font-changing elements are listed in the parameter entity `%font-change`. Their meaning is listed in Table 4.

Table 4: The font-changing and font-decoration elements.

Element	Sample input	Sample output
<i>Font-decoration elements</i>		
<code>ce:underline</code>	<code>&lt;ce:underline&gt;any&lt;/ce:underline&gt;</code>	<u>any</u>
<code>ce:cross-out</code>	<code>&lt;ce:cross-out&gt;any&lt;/ce:cross-out&gt;</code>	<del>any</del>
<i>Font-style changing elements</i>		
<code>ce:italic</code>	<code>&lt;ce:italic&gt;any&lt;/ce:italic&gt;</code>	<i>any</i>
<code>ce:bold</code>	<code>&lt;ce:bold&gt;P&lt;/ce:bold&gt;(x)</code>	<b>P(x)</b>
<code>ce:small-caps</code>	<code>&lt;ce:small-caps&gt;Goldfarb&lt;/ce:small-caps&gt;</code>	GOLDFARB
<i>Font-family changing elements</i>		
<code>ce:monospace</code>	<code>&lt;ce:monospace&gt;var&lt;/ce:monospace&gt;</code>	var
<code>ce:sans-serif</code>	<code>&lt;ce:sans-serif&gt;A&lt;/ce:sans-serif&gt;</code>	A

The default font, i.e. the font that is used when no font-changing element is open, is defined by the journal style. In print that is the journal's typesetting instructions. There are no font-changing elements to set the font to the default font. One can only revert to the default font by closing all font-changing elements.

### Combinations of font-changing and font-decoration elements

For all types of font-changing and font-decoration elements that can be combined with each other, the order in which they are opened is irrelevant.

*Font-family changing elements* `ce:sans-serif`, `ce:monospace`. The font-family changing elements `ce:sans-serif` and `ce:monospace` are mutually exclusive. If these elements

are nested, the outer font-family changing element loses its effect until the inner font-family changing element is closed.

*Font-style changing elements* `ce:italic`, `ce:bold` and `ce:small-caps` and *font-decoration elements* `ce:cross-out`, `ce:underline`. The font-style changing elements `ce:italic`, `ce:bold` and `ce:small-caps` and the font-decoration elements `ce:cross-out` and `ce:underline` can be combined with each other and with each of the font-family changing elements. The font-style changing elements have the effect of changing the style of the current font. The font-decoration elements have the effect of adding underlining or cross-out to the current font.

*Text effect element* `ce:br`. Text element `ce:br` can only be used in cells.

## Copy edit considerations

Care must be taken that font-changing elements are switched off to avoid unwanted effects. For instance, compare the following two examples where a formula is structured outside MathML (which is to be avoided):

*XML*

```
<ce:italic>f(x<ce:sup>2</ce:sup></ce:italic>
```

*Presentation*

*f(x<sup>2</sup>)*

*Explanation*

Observe that the parentheses and the superior 2 are italicized.

*XML*

```
<ce:italic>f</ce:italic><ce:italic>x</ce:italic><ce:sup>2</ce:sup>
```

*Presentation*

*f(x<sup>2</sup>)*

Font-changing and font-decoration elements cannot contain anchors and cross-references. When such an element occurs in a text with a font change or decoration, the font-changing or font-decoration elements must be closed before the element, opened at the start of the element's content and closed again at its end, and opened again after the element.

*XML*

```
<ce:italic>See
</ce:italic><ce:cross-ref refid="bib2"><ce:italic>Ref.
[2]</ce:italic></ce:cross-ref><ce:italic> for
an important restriction.</ce:italic>
```

*Presentation*

*See Ref. [2] for an important restriction.*

Font-changing elements should not be used to introduce a style. For instance, if titles are to be displayed in caps and small caps, this should be handled by the document style and not by the use of the element `ce:small-caps`.

## Rendering notes

Rendering applications should be aware that certain glyphs may change appearance when a font-changing element is applied (e.g. a sans-serif “jnodot”).



## Version history

Prior to DTD 5.0, elements `ce:italic`, `ce:bold`, `ce:small-caps`, `ce:monospace` and `ce:sans-serif` were called `it`, `b`, `scp`, `ty` and `ssf`, respectively.

As open-face, German (fraktur) and script characters should only appear in math mode, the elements `of`, `ge` and `sc` have no counterparts in DTD 5.0. See the chapter on MathML (Chapter 9, p. 445) for more information.

The elements `ce:cross-out` and `ce:underline` were introduced in DTD 5.0 by popular demand.

## Parameter entities

Here we list the parameter entities that are used in the DTD. Parameter entities are used to define common parts of the DTD, i.e., parts that are (or could be) used several times. We distinguish three groups of parameter entities, according to their role in the DTD.

### Data entities

Data entities contain elements that appear within the text; each data entity contains a group of elements that play a similar role in the structuring of an article, and that therefore appear as alternatives of each other.

```
<!ENTITY % font-change      "ce:bold|ce:italic|ce:monospace|ce:sans-serif|
                             ce:small-caps">
<!ENTITY % text-effect      "%font-change;|ce:sup|ce:inf|ce:underline|
                             ce:cross-out|ce:hsp|ce:vsp">
<!ENTITY % lists            "ce:def-list|ce:list">
<!ENTITY % display          "ce:display|ce:displayed-quote|ce:enunciation">
<!ENTITY % string.data      "#PCDATA %local.string.data;">
<!ENTITY % richstring.data  "#PCDATA|ce:glyph|%text-effect;|
                             ce:inline-figure %local.richstring.data;">
<!ENTITY % text.data        "%richstring.data;|mml:math %local.text.data;">
<!ENTITY % textfn.data      "%text.data;|ce:footnote|
                             %cross-ref-s; %local.textfn.data;">
<!ENTITY % textref.data     "%text.data;|%cross-ref-s;|
                             %inter-ref-s; %local.textref.data;">
<!ENTITY % nondisplay.data  "%textref.data;|ce:footnote|
                             ce:anchor %local.nondisplay.data;">
<!ENTITY % note.data        "%textref.data;|%display;|%lists;|
                             ce:anchor %local.note.data;">
<!ENTITY % cell.data        "%textref.data;|%display;|%lists;|%cell-borders;|
                             tb:alignmark|ce:br %local.cell.data;">
<!ENTITY % spar.data        "%textref.data;|%display;|%lists;|ce:footnote|
                             ce:anchor %local.spar.data;">
<!ENTITY % par.data         "%textref.data;|ce:float-anchor|%display;|
                             %lists;|ce:footnote|ce:anchor %local.par.data;">
```

The “local” entities, e.g. `%local.par.data`; or `%local.spar.data`; , are all declared to be empty in the common element pool. However, they can be used by DTDs to add elements to the content of the data entities. For example, in books it is useful to add information to the text that can later be used to generate an index. This can be done with `ce:index-flag`. The EHS Books DTD therefore declares the following two “local” entities:

```
<!ENTITY % local.spar.data  "| ce:index-flag">
<!ENTITY % local.par.data   "| ce:index-flag">
```

The effect is that `ce:index-flag` can appear in any element that has `%par.data`; or `%spar.data`; in its content model.

Table 5: Content model of data elements

Parameter entity	Elements with that data model
<code>%string.data;</code>	<code>ce:copyright, ce:doi, ce:edition, ce:indexed-name, ce:initials, ce:isbn, ce:issn, ce:pii, sb:isbn, sb:issn</code>
<code>%richstring.data;</code>	<code>ce:anchor, ce:bold, ce:copyright-line, ce:cross-out, ce:degrees, ce:first-page, ce:given-name, ce:imprint, ce:inf, sb:issue-nr, ce:italic, ce:last-page, ce:monospace, ce:ranking, ce:roles, ce:sans-serif, ce:small-caps, ce:suffix, ce:sup, ce:underline, sb:date, sb:edition, sb:first-page, sb:issue-nr, sb:last-page, sb:location, sb:name, sb:volume-nr</code>
<code>%text.data;</code>	<code>ce:collab-aff, ce:compound-formula, ce:compound-name, ce:cross-ref, ce:cross-refs, ce:def-term, ce:e-address, ce:glossary-def, ce:index-flag-term, ce:index-flag-see, ce:index-flag-see-also, ce:inter-ref, ce:inter-ref-title, ce:inter-refs-text, ce:intra-ref, ce:intra-ref-title, ce:intra-refs-text, ce:label, ce:miscellaneous, ce:salutation, ce:see, ce:see-also, ce:surname, ce:text, sb:collaboration, sb:conference, sb:maintitle, sb:subtitle</code>
<code>%textfn.data;</code>	<code>ce:alt-title, ce:alt-subtitle, ce:chem, ce:dedication, ce:presented, ce:subtitle, ce:textfn, ce:title</code>
<code>%textref.data;</code>	<code>ce:glossary-heading, ce:index-heading, ce:textref</code>
<code>%nondisplay.data;</code>	<code>ce:section-title, sb:comment, mml:mtext</code>
<code>%note.data;</code>	<code>ce:note-para</code>
<code>%cell.data;</code>	<code>entry</code>
<code>%spar.data;</code>	<code>ce:simple-para</code>
<code>%par.data;</code>	<code>ce:para</code>

The above `.data` entities were introduced to make the DTD more restrictive. Table 5 shows which elements in the common element pool have which parameter entity as content model.

The general-purpose elements `ce:text`, `ce:textfn` and `ce:textref` use these data entities also and are used as containers in order to avoid mixed content.

To find out which elements can be used in e.g. `%textfn.data`; the parameter entities in its model need to be expanded. Parameter entities in an expanded model also need to be expanded, etc. If we take the “local” entities to be empty, then it becomes clear that `%textfn.data`; can contain everything `%text.data`; can contain as well as the elements `ce:footnote`, `ce:cross-ref`, `ce:cross-refs`, `ce:inter-ref` and `ce:inter-refs`. Entity `%textref.data`; can contain the same elements as `%textfn.data`; except for `ce:footnote`; additionally elements `ce:inter-ref` and `ce:inter-refs` are allowed.

The elements `ce:note-para` and `ce:simple-para` are variants of the paragraph element in which fewer structures are allowed. The following elements consist of simple paragraphs: `ce:abstract-sec`, `ce:biography`, `ce:caption`, `ce:legend`, `ce:note` (in the bibliography), `ce:displayed-quote`. The following elements consist of note paragraphs: `ce:article-footnote`, `ce:footnote`, `ce:table-footnote`.

### Content model entities

Content model entities contain pieces of content model that are shared by several elements.

```

<!ENTITY % copyright      "ce:copyright">
<!ENTITY % name           "( ( ce:given-name, ce:surname ) | ( ce:surname,
                           ce:given-name? ) ), ce:suffix?">
<!ENTITY % parsec         "( ce:para | ce:section )+>
<!ENTITY % titles         "( ce:title, ce:subtitle?, ( ce:alt-title,
                           ce:alt-subtitle? )* )">
<!ENTITY % sb.titles      "( ( sb:title, sb:translated-title? ) |
                           sb:translated-title )">
<!ENTITY % cross-ref-s    "%cross-ref;%cross-refs;">
<!ENTITY % inter-ref-s    "ce:inter-ref|ce:inter-refs">
<!ENTITY % cell-borders   "tb:top-border|tb:left-border|tb:bottom-border|
                           tb:right-border">

```

The following parameter entities are overruled by other DTDs. The local declarations are described in the documentation of the other DTDs. Below are the default values.

```

<!ENTITY % see            "ce:see">
<!ENTITY % glossary-entry-refs"( ce:cross-ref | ce:intra-ref )+>
<!ENTITY % index-entry-refs"( ce:see | ( ce:cross-ref | ce:intra-ref )+ )">
<!ENTITY % cross-ref      "ce:cross-ref|ce:intra-ref">
<!ENTITY % cross-refs     "ce:cross-refs|ce:intra-refs">

```

### Attribute type entities

Attribute type entities contain sets of possible values for attributes.

```

<!ENTITY % abstract-class "(author|editor|graphical|teaser)">
<!ENTITY % copyright-type "(full-transfer|limited-transfer|no-transfer|
                           unknown|us-gov|crown|society|other|joint)">
<!ENTITY % e-address-type "(email|url)">
<!ENTITY % hline           "(bar|tcub|bcub|tsqb|bsqb|circ|tilde|larr|rarr|
                           harr|lharu|rharu|tpar|bpar)">
<!ENTITY % language        "(de|en|es|fr|it|pt|ru)">
<!ENTITY % language-type   "(en|non-en|iso|unknown)">
<!ENTITY % loc             "(pre|post)">
<!ENTITY % style           "(s|d|t|da|dot|b|bl|n)">
<!ENTITY % view            "(compact|standard|extended|compact-standard|
                           standard-extended|all)">
<!ENTITY % vline           "(lpar|rpar|lsqb|rsqb|lcub|rcub|lang|rang|vb|sol|
                           bsol|lceil|rceil|lfloor|rfloor|dharr|uharr|darr|
                           uarr|varr)">

```

In addition there are the attribute type entities [%iso639](#); and [%glyph-names](#);

Entity [%iso639](#); contains the ISO 639 list of language codes. These codes are described in a separate [section](#) (p. 162).

Entity `%glyph-names`; contains the names of additional allowed glyphs (not present as Unicode characters). They are described in the section [Elsevier's additional glyphs](#) (p. 26). See also the description of `ce:glyph`.

```
<!ENTITY % iso639-cur      "aa|ab|af|am|ar|as|ay|az|ba|be|bg|bh|bi|bn|bo|br|
ca|co|cs|cy|da|de|dz|el|en|eo|es|et|eu|fa|fi|fj|
fo|fr|fy|ga|gd|gl|gn|gu|ha|he|hi|hr|hu|hy|ia|id|
ie|ik|is|it|ja|jw|ka|kk|kl|km|kn|ko|ks|ku|ky|la|
ln|lo|lt|lv|mg|mi|mk|ml|mn|mo|mr|ms|mt|my|na|ne|
nl|no|oc|om|or|pa|pl|ps|pt|qu|rm|rn|ro|ru|rw|sa|
sd|sg|si|sk|sl|sm|sn|so|sq|sr|ss|st|su|sv|sw|ta|
te|tg|th|ti|tk|tl|tn|to|tr|ts|tt|tw|uk|ur|uz|vi|
vo|wo|xh|yi|yo|zh|zu">

<!ENTITY % iso639-obs     "">

<!ENTITY % iso639        "(%iso639-cur; %iso639-obs;)">

<!ENTITY % glyph-names   "'(S|bigdot|btm|lig|camb|ctl|dbnd|dbnd6|dcurt|
dlcorn|drcorn|ggrave|hbar|heng|herma|hris|hriss|
hrttrh|ht|jnodot|lbd2bd|lbd2td|lbond2|lbond3|
lozf|lozfl|lozfr|lris|lriss|ncurt|nsmid|nspar|
pSlash|pbdtd|pdbond|pent|phktp|ptbdbd|ptbtd|
qbd|qbd6|rad|rbd2bd|rbd2td|rbond2|rbond3|
refhrl|resmck|risfla|risfls|sbnd|sbw|smid|spar|
sqfb|sqfne|sqfsw|sqft|tbnd|tbnd6|tcurt|trisla|
trnomeg)'">
```

## ISO 639 list of language codes

This section gives a description of the two-letter languages codes from International Standard ISO 639. These codes are used by all elements whose `xml:lang` attributes take their values in `%iso639;`.

language	Language	language	Language	language	Language
ab	Abkhazian	is	Icelandic	ro	Romanian
aa	Afar	id	Indonesian	rn	Rundi
af	Afrikaans	ia	Interlingua	ru	Russian
sq	Albanian	ie	Interlingue	sm	Samoan
am	Amharic	ik	Inupiaq	sg	Sango
ar	Arabic	ga	Irish Gaelic	sa	Sanskrit
hy	Armenian	it	Italian	gd	Scots Gaelic
as	Assamese	ja	Japanese	sr	Serbian
ay	Aymara	jw	Javanese	sn	Shona
az	Azerbaijani	kl	Kalaallisut	sd	Sindhi
ba	Bashkir	kn	Kannada	si	Sinhalese
eu	Basque	ks	Kashmiri	sk	Slovak
bn	Bengali	kk	Kazakh	sl	Slovenian
bh	Bihari	km	Khmer	so	Somali
bi	Bislama	rw	Kinyarwanda	st	Southern Sotho
br	Breton	ky	Kirghiz	es	Spanish
bg	Bulgarian	ko	Korean	su	Sudanese
my	Burmese	ku	Kurdish	sw	Swahili
be	Belarusian	lo	Lao	ss	Swati
ca	Catalan	la	Latin	sv	Swedish
zh	Chinese	lv	Latvian	tl	Tagalog
co	Corsican	ln	Lingala	tg	Tajik
hr	Croatian	lt	Lithuanian	ta	Tamil
cs	Czech	mk	Macedonian	tt	Tatar
da	Danish	mg	Malagasy	te	Telugu
nl	Dutch	ms	Malay	th	Thai
dz	Dzongkha	ml	Malayalam	bo	Tibetan
en	English	mt	Maltese	ti	Tigrinya
eo	Esperanto	mi	Maori	to	Tonga
et	Estonian	mr	Marathi	ts	Tsonga
fo	Faroese	mo	Moldavian	tn	Tswana
fj	Fijian	mn	Mongolian	tr	Turkish
fi	Finnish	na	Nauru	tk	Turkmen
fr	French	ne	Nepali	tw	Twi
fy	Frisian	no	Norwegian	uk	Ukrainian
gl	Gallegan	oc	Occitan	ur	Urdu
ka	Georgian	or	Oriya	uz	Uzbek
de	German	om	Oromo	vi	Vietnamese
el	Greek	pa	Panjabi	vo	Volapük
gn	Guarani	fa	Persian	cy	Welsh
gu	Gujarati	pl	Polish	wo	Wolof
ha	Hausa	pt	Portuguese	xh	Xhosa
he	Hebrew	ps	Pushto	yi	Yiddish
hi	Hindi	qu	Quechua	yo	Yoruba
hu	Hungarian	rm	Rhaeto-Romance	zu	Zulu

## Views

The need to distinguish several product types and to support these from a single source XML file, has led to the introduction of the `view` attribute. The following common elements possess a `view` attribute: `ce:appendices`, `ce:bibliography`, `ce:biography`, `ce:exam-answers`, `ce:exam-questions`, `ce:exam-reference`, `ce:further-reading`, `ce:glossary`, `ce:include-item`, `ce:index`, `ce:para`, `ce:section` and `ce:simple-para`. Some elements in the DTDs also possess this attribute, e.g. `body` in the JA DTD.

The values that this attribute can take are listed in `%view`; they are: `compact`, `standard`, `extended`, `compact-standard`, `standard-extended` and `all` (default, meaning all three views). If no `view` attribute is specified, this is the same as `all`.

In this model, an application decides it is either “compact”, “standard” or “extended”. An application that has, say, extended views displays all elements whose `view` attribute has values `all`, `standard-extended` and `extended` and ignores all elements with other values.

Application	Render only elements with views
compact	<code>all</code> , <code>compact</code> , <code>compact-standard</code>
standard	<code>all</code> , <code>standard</code> , <code>compact-standard</code> , <code>standard-extended</code>
extended	<code>all</code> , <code>extended</code> , <code>standard-extended</code>

Online applications such as ScienceDirect<sup>®</sup> are typically “extended” applications, while the printed version typically is “standard”. Palmtop devices and such could be “compact”.

### Online versus extended

While it is useful to visualize “extended” as the online product and standard as the print product, this is not necessarily the case. It should be perfectly possible to print an extended product—or, create a web PDF file for it. There are numerous cases of products where a PDF file appears online of a full journal article, while the printed issue only contains the abstract.

Views should not be confused with electronic components. Electronic components are captured with `ce:e-component`. These are external files that in principle could contain anything. It is mistake to think that these can only appear in “extended” views; indeed, they can appear in compact, standard and extended views. On paper, this means showing the `ce:alt-e-component` subelement, only in electronic products one can, of course, benefit from the real electronic component. Note that a web PDF file, although an “electronic file”, is not suitable for e-components, yet, as explained above, it may well contain the extended view.

Floats (figures, tables, textboxes, electronic components) that only appear within some views, say only in extended views, are contained within `ce:floats` along with the other floats. Their `ce:float-anchor` can be found within an extended section or paragraph.

Hence, e-component vs. conventional and standard view vs. extended view are two independent things, indeed all four combinations make sense, including:

- A figure within an extended view. This is a figure that satisfies all the CAP specifications for artwork regarding file types and resolution.

- An e-component within *any* view. This can, in principle, be any external component varying: audio, video, spreadsheets, source documents. Still images can also be e-components: this signals that the artwork has not undergone the stringent CAP validation. In media that cannot handle the e-component, `ce:alt-e-component` is used.

### Views within views

Applications choose to be exactly one of “compact”, “standard”, or “extended”. If an application encounters an element with a view that is not meant for it, it should skip the element completely, irrespective of what it contains.

For instance, if an “extended” application encounters a section with view `compact-standard`, it ignores that whole section completely. If, within that section there happen to be paragraphs or sections with views `extended`, then these will *not* display in the extended application at all, and also the paragraphs with the default view `all` will not be picked up by the extended application. Consequently, views within views only make sense if they narrow down the view.

### Example 1.

The first example deals with a collection of electronic components that are added to the online version. The printed version only contains a link to the online version.

*XML*

```
<ce:appendices>
  <ce:section view="compact-standard">
    <ce:label>Appendix A</ce:label>
    <ce:section-title>Background data</ce:section-title>
    <ce:para>The online version of this article contains additional
      background data in the form of Microsoft Excel
      spreadsheets and in additional maps. Please visit
      <ce:inter-ref xlink:href="doi:10.1016/j.cagd.2004.01.003">
        http://dx.doi.org/10.1016/j.cagd.2004.01.003</ce:inter-ref>.
    </ce:para>
  </ce:section>
  <ce:section view="extended">
    <ce:label>Appendix A</ce:label>
    <ce:section-title>Background data</ce:section-title>
    <ce:para>The results of the experiments of the previous sections
      are included as Microsoft Excel spreadsheets. The first
      spreadsheet, <ce:cross-ref refid="ec1">Spreadsheet
      1</ce:cross-ref><ce:float-anchor refid="ec1"/> is ordered
      by country, while <ce:cross-refs refid="ec2 ec3">Spreadsheets
      2 and 3</ce:cross-refs><ce:float-anchor refid="ec2"/>
      <ce:float-anchor refid="ec3"/> are ordered by population.
    </ce:para>
    <ce:para>Furthermore, the data is displayed in thirty-seven
      maps of the largest world cities, <ce:cross-refs refid="map1
      map2 ... map37">Maps I&ndash;XXXVII</ce:cross-refs>
      <ce:float-anchor refid="map1"/>...
      <ce:float-anchor refid="map37"/>.
    </ce:para>
  </ce:section>
```

*Explanation*

The printed product would display the first `ce:section`, explaining that the online version contains additional background data. The second `ce:section` would be displayed by



ScienceDirect®.

The float anchors refer to electronic components within `ce:floats`.

### Example 2

In some publications, it is common to publish the appendices only online. The printed product only contains the main body of the text. This is achieved using `ce:appendices` with an extended view.

Similarly, there are journals for which some less important articles only appear full text online; the printed product merely contains the head of the article. This is achieved by furnishing `body` and `tail` with an extended view only.

### Cross-referencing to the right view

It is only allowed to cross-reference to a destination that is contained within equal or wider view than where the cross-reference appears, so as to avoid linking to a destination that does not exist in a certain rendering.

Suppose that there are two sections, one compact-standard and one extended, created in order to obtain two parallel views of the section. Suppose both sections contain a version of the same enunciation Theorem 1. Then the only way to cross-reference to Theorem 1 from within a portion of the text is to also create two parallel paragraphs with different views, each containing a `ce:cross-ref` to the appropriate version of the enunciation.



## Chapter 7

# The Elements of the CEP

This chapter contains an alphabetic listing of the elements in the “core” common element pool; i.e., it excludes the elements for structuring bibliographic references, MathML and Extended CALS tables.

## ce:abstract

### Declaration

#### Model (CEPs 1.1.0–1.1.5)

```
<!ELEMENT ce:abstract ( ce:section-title?, ce:abstract-sec+,
                        ce:figure? )>
<!ATTLIST ce:abstract
  id          ID          #IMPLIED
  class       %abstract-class; "author"
  xml:lang    %iso639;    #IMPLIED>
```

#### Model (CEP 1.1.6)

```
<!ELEMENT ce:abstract ( ce:section-title?, ce:abstract-sec+,
                        ce:figure? )>
<!ATTLIST ce:abstract
  id          ID          #IMPLIED
  view        %view;      'all'
  class       %abstract-class; "author"
  xml:lang    %iso639;    #IMPLIED>
```

### Description

The element `ce:abstract` is used to capture abstracts in a variety of forms.

### Usage

The word “abstract” has various different meanings in publishing. For instance, a very short article, often in conference proceedings, is called an abstract, and so are short summaries of articles or chapters appearing in the frontmatter. The element `ce:abstract` is used to capture abstracts in the latter sense. It consists of an optional title, one or more abstract-sections, and an optional figure. It has three attributes, `id` (required), `class` and `xml:lang`. For each combination of `class` and `xml:lang`, only one abstract may exist in the document.

The language of the abstract, when different from the language of the article, should be specified in the `xml:lang` attribute. It takes its values in the [ISO 639 set of entities](#) (p. 162).

The type of abstract is specified by the `class` attribute, which takes its values in `%abstract-class`; containing the following values.

- `author` (default) is used for abstracts supplied by the author.
- `editor` is used for abstracts supplied by the editor.
- `graphical` is used for graphical abstracts. Only these abstracts may contain the optional `ce:figure`.
- `teaser` is used for short “teaser” abstracts that attract the attention of the reader. Usually, the teaser abstracts are not found in the rendering of the item itself; instead, they are commonly used to create an extended table of contents of an issue (i.e., a table of contents interspersed with teaser abstracts).

*XML*

```

<ce:abstract>
  <ce:section-title>Abstract</ce:section-title>
  <ce:abstract-sec>
    <ce:simple-para>In this document, we introduce the new
      XML DTD.</ce:simple-para>
  </ce:abstract-sec>
</ce:abstract>
<ce:abstract xml:lang="fr">
  <ce:section-title>Résumé</ce:section-title>
  <ce:abstract-sec>
    <ce:simple-para>Dans ce document, on présente le nouveau
      DTD XML.</ce:simple-para>
  </ce:abstract-sec>
</ce:abstract>

```

Abstract sections may have a section title, and each `ce:abstract-sec` except the first must have a section title.

Graphical abstracts have a `ce:figure`. If they contain text, this text comes in the usual place, in `ce:abstract-sec` elements before the figure.

*XML*

```

<ce:abstract class="graphical">
  <ce:section-title>Graphical abstract</ce:section-title>
  <ce:abstract-sec>
    <ce:simple-para>Copper chloride-catalyzed S-arylation of
      arenethiols is effected with activated aryl chlorides
      in water by using ethylenediamine as the pair
      ligand/base.</ce:simple-para>
  </ce:abstract-sec>
  <ce:figure>
    <ce:link locator="fx1"/>
  </ce:figure>
</ce:abstract>

```

*Presentation*

Copper chloride-catalyzed S-arylation of arenethiols is effected with activated aryl chlorides in water by using ethylenediamine as the pair ligand/base.

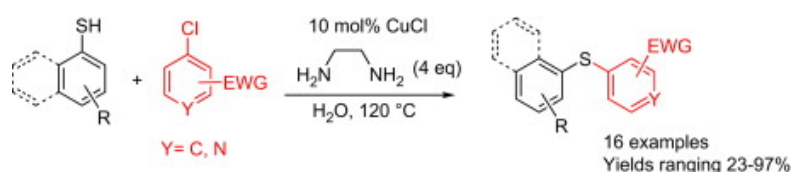

## Rendering notes

Abstracts, especially of the non-author classes, are not necessarily presented in the article. It is not uncommon for abstracts to be presented in an extended table of contents.

Copyright lines appended to the abstract are implied by the `ce:copyright` element.

## Version history

Prior to DTD 5.0, this element was called `abs`. Then the heading was generated automatically, it did not contain an `id` attribute, and the `class` attribute had no default value. As

from CEP 1.1.0 the `xml:lang` attribute takes its values in [%iso639](#). The `view` attribute was added in CEP 1.1.6.

## ce:abstract-sec

### Declaration

#### Model (CEPs 1.1.0–1.1.5)

```
<!ELEMENT ce:abstract-sec ( ce:section-title?, ce:simple-para+ )>
```

#### Model (CEP 1.1.6)

```
<!ELEMENT ce:abstract-sec ( ce:section-title?, ce:simple-para+ )>
```

```
<!ATTLIST ce:abstract-sec
```

id	ID	#IMPLIED
view	%view;	'all'>

### Description

The element `ce:abstract-sec` contains a section within the abstract.

### Usage

See `ce:abstract`.

### Version history

The `id` and `view` attributes were added in CEP 1.1.6.

## ce:acknowledgment

### Declaration

#### Model (CEPs 1.1.0–1.1.5)

```
<!ELEMENT ce:acknowledgment ( ce:section-title?, ce:para+ )>
<!ATTLIST ce:acknowledgment
  id ID #IMPLIED>
```

#### Model (CEP 1.1.6)

```
<!ELEMENT ce:acknowledgment ( ce:section-title?, ce:para+ )>
<!ATTLIST ce:acknowledgment
  id ID #IMPLIED
  role CDATA #IMPLIED
  view %view; 'all'>
```

### Description

The element `ce:acknowledgment` is used to capture the acknowledgment section within the body.

### Usage

The acknowledgment section has an optional section title and consists of one or more paragraphs.

*XML*

```
<ce:acknowledgment>
  <ce:section-title>Acknowledgment</ce:section-title>
  <ce:para>The authors thank Jeroen Hogendorp,
    Chris Sturhann and Michael Ward
    for their helpful comments.</ce:para>
</ce:acknowledgment>
```

### Version history

Prior to DTD 5.0, this element was called `ack`. Then it did not have a `ce:section-title`. The `role` and `view` attributes were added in CEP 1.1.6.

### See also

`ce:grant-number`, `ce:grant-sponsor`



## ce:affiliation

### Declaration

#### Model (CEPs 1.1.0–1.1.6)

```
<!ELEMENT ce:affiliation      ( ce:label?, ce:textfn )>
<!ATTLIST ce:affiliation
          id          ID          #IMPLIED
          role       CDATA       #IMPLIED>
```

### Description

Affiliations are captured using the element [ce:affiliation](#).

### Usage

An author group ([ce:author-group](#)) may contain any number of affiliations.

It is allowed to have affiliations with no associated authors or collaborations. Such affiliations cannot have an [id](#), because each affiliation with an [id](#) must be referred to. An affiliation with an [id](#) must have a [ce:label](#) element.

The [ce:label](#) element does not contain presentational elements, only the label of the affiliation. Linking of affiliations to authors is described under the [ce:author-group](#) element.

The actual content of the affiliation is found within the [ce:textfn](#) container subelement.

#### XML

```
<ce:affiliation id="aff1">
  <ce:label>a</ce:label>
  <ce:textfn>Elsevier, Radarweg 29,
    1043 NX Amsterdam, The Netherlands</ce:textfn>
</ce:affiliation>
<ce:affiliation id="aff2">
  <ce:label>b</ce:label>
  <ce:textfn>Elsevier Inc., P.O. Box 945, New York,
    NY 10159-0945, USA</ce:textfn>
</ce:affiliation>
<ce:affiliation id="aff3">
  <ce:label>c</ce:label>
  <ce:textfn>Elsevier Ltd, The Boulevard, Langford Lane,
    Kidlington, Oxford OX5 1GB, UK</ce:textfn>
</ce:affiliation>
```

### See also

[ce:author-group](#)

## ce:alt-e-component

### Declaration

#### Model (CEPs 1.1.0–1.1.1)

```
<!ELEMENT ce:alt-e-component ( ce:link | ( ce:caption, ce:link? ) )>
```

#### Model (CEPs 1.1.2–1.1.6)

```
<!ELEMENT ce:alt-e-component ( ce:link | ( ce:caption+, ce:link? ) )>
```

### Description

The element `ce:alt-e-component` contains an alternative to an electronic component, e.g. a frame of a movie.

### Usage

See `ce:e-component`.

### Version history

As from CEP 1.1.2 the caption is repeatable.

## ce:alt-subtitle

### Declaration

#### Model (CEPs 1.1.0–1.1.4)

```
<!ELEMENT ce:alt-subtitle ( %textfn.data; )*>
<!ATTLIST ce:alt-subtitle
  xml:lang %language; #REQUIRED>
```

#### Model (CEPs 1.1.5, 1.1.6)

```
<!ELEMENT ce:alt-subtitle ( %textfn.data; )*>
<!ATTLIST ce:alt-subtitle
  xml:lang %iso639; #REQUIRED>
```

### Description

The element `ce:alt-subtitle` contains the subtitle of an article, chapter, or other item.

### Usage

The element `ce:alt-subtitle` is used to capture the subtitle of an item, e.g. a journal article or book chapter, in an alternative language. It has one mandatory attribute `xml:lang`, which specifies the language of the alternative title. See Section 7.5 (p. 162) for an overview of the allowed language codes.

For more information about subtitles, see `ce:subtitle`.

#### XML

```
<ce:title>The Common Element Pool</ce:title>
<ce:subtitle>A modular approach to DTD design</ce:subtitle>
<ce:alt-title xml:lang="de">Der Pool der gemeinsamen
  Elemente</ce:alt-title>
<ce:alt-subtitle xml:lang="de">Eine modulare Weise des DTD
  Entwurfs</ce:alt-subtitle>
```

### Version history

In DTDs prior to DTD 5.0, the element `sbt` fulfilled the function of both `ce:subtitle` and `ce:alt-subtitle`; the language was specified in the parent `at1` element. In CEP 1.1.1 the value it was added to parameter entity `%language;`. As of CEP 1.1.5, all languages contained in `%iso639;` are allowed.

### See also

[ce:alt-title](#), [ce:subtitle](#), [ce:title](#)

## ce:alt-title

### Declaration

#### Model (CEPs 1.1.0–1.1.4)

```
<!ELEMENT ce:alt-title ( %textfn.data; )*>
<!ATTLIST ce:alt-title
  xml:lang %language; #REQUIRED>
```

#### Model (CEPs 1.1.5, 1.1.6)

```
<!ELEMENT ce:alt-title ( %textfn.data; )*>
<!ATTLIST ce:alt-title
  xml:lang %iso639; #REQUIRED>
```

### Description

The element `ce:alt-title` contains a title of an article, chapter, or other item, in an alternative language.

### Usage

The element `ce:alt-title` is used to capture a title in a language different from the language of the item; it occurs one or more times within its parent element. It has one mandatory attribute `xml:lang`, which specifies the language of the alternative title. See Section 7.5 (p. 162) for an overview of the allowed language codes.

*XML*

```
<ce:title>The Common Element Pool (CEP)</ce:title>
<ce:alt-title xml:lang="fr">Le Dépôt des Eléments Communs
(DEC)</ce:alt-title>
```

### Version history

In DTDs prior to DTD 5.0, the element `at1` fulfilled the function of both `ce:title` and `ce:alt-title`; moreover, it contained the subtitle within it. In CEP 1.1.1 the value it was added to parameter entity `%language;`. As of CEP 1.1.5 the complete list of languages contained in `%iso639;` can be used.

### See also

[ce:alt-subtitle](#), [ce:subtitle](#), [ce:title](#)

## ce:anchor

### Declaration

#### Model (CEPs 1.1.0–1.1.6)

```
<!ELEMENT ce:anchor ( %richstring.data; )*>
<!ATTLIST ce:anchor
  id ID #REQUIRED
  role CDATA #IMPLIED>
```

### Description

The element `ce:anchor` is a piece of text that can be the target of a cross-reference.

### Usage

An anchor is a (possibly empty) piece of text that can be the target of a cross-reference. It is similar to `<A NAME="...">` in HTML.

Anchor is special because it may have empty content, and it is an element referred without possessing a `ce:label` element.

*XML*

```
<ce:anchor id="anc1">CH<ce:inf>3</ce:inf>C<ce:glyph
  name="tbnd6"/>N (<ce:bold>23</ce:bold></ce:anchor>
...
a solution containing 20mmol of
<ce:cross-ref refid="anc1"><ce:bold>23</ce:bold></ce:cross-ref>
```

The attribute `role` can be used to attach a certain meaning to the anchor. Currently no roles have been defined.

### Light reading

`ce:anchor` may not be used in CONTENTS-ENTRY-ONLY, HEAD-ONLY or HEAD-AND-TAIL files.

## ce:appendices

### Declaration

#### Model (CEPs 1.1.0–1.1.6)

```
<!ELEMENT ce:appendices ( ce:section+ )>
<!ATTLIST ce:appendices
  view %view; 'all'>
```

### Description

The element `ce:appendices` contains the appendix matter (consisting of one or more appendices, each a `ce:section`) of a document.

#### XML

```
<ce:appendices>
  <ce:section id="app1">
    <ce:label>Appendix A</ce:label>
    <ce:section-title>Answers to the exercises</ce:section-title>
    ...
  </ce:section>
  <ce:section id="app2">
    <ce:label>Appendix B</ce:label>
    <ce:section-title>Basic skills</ce:section-title>
    ...
  </ce:section>
</ce:appendices>
```

#### Presentation

**Appendix A. Answers to the exercises**

...

**Appendix B. Basic skills**

...

#### XML

```
<ce:appendices>
  <ce:section id="apple" view="extended">
    <ce:label>Appendix A</ce:label>
    <ce:section-title>Supplementary data</ce:section-title>
    <ce:para>Supplementary data associated with this
      article ...
    </ce:section>
  <ce:section id="app1cs" view="compact-standard">
    <ce:label>Appendix A</ce:label>
    <ce:section-title>Supplementary data</ce:section-title>
    <ce:para>This appendix contains background data of
      our experiment in the form of four spreadsheets.
    ...
  </ce:section>
</ce:appendices>
```

#### Presentation

**Appendix A. Supplementary data**

Supplementary data associated with this article can be found in the online version, at doi:10.1016/j.endend.2003.07.001.

*Explanation*

The above presentation is the compact-standard version.

**Version history**

The [view](#) attribute was added in CEP 1.1.0.

**See also**

[ce:section](#)

## ce:article-footnote

### Declaration

#### Model (CEPs 1.1.0–1.1.5)

```
<!ELEMENT ce:article-footnote ( ce:label?, ce:note-para+ )>
```

#### Model (CEP 1.1.6)

```
<!ELEMENT ce:article-footnote ( ce:label?, ce:note-para+ )>
<!ATTLIST ce:article-footnote
  role          CDATA          #IMPLIED>
```

### Description

The element `ce:article-footnote` is used to capture “article footnotes”. These are footnotes that are commonly displayed at the title, and that contain information relevant to the whole article. Important information that must be presented with any rendering of the article, such as acknowledgment of grants, is usually the content of the `ce:article-footnote`.

### Usage

Each article footnote is a separate `ce:article-footnote` which consists of the footnote symbol in `ce:label` and a sequence of note paragraphs, `ce:note-para`.

#### XML

```
<ce:article-footnote>
  <ce:label>&z.star;</ce:label>
  <ce:note-para>An earlier version of this article
    appeared in ...</ce:note-para>
</ce:article-footnote>
<ce:article-footnote>
  <ce:label>&z.star;&z.star;</ce:label>
  <ce:note-para>This work was supported by NSF NYI grant
    CCR-9457806.</ce:note-para>
</ce:article-footnote>
```

### Version history

Prior to DTD 5.0, the element was called `at1fn`. Then it did not contain a separate element for the footnote label. The `role` attribute was added in CEP 1.1.6.



## ce:author

### Declaration

#### Model (CEPs 1.1.0–1.1.1)

```
<!ELEMENT ce:author ( ce:initials?, ce:indexed-name?,
                      ce:degrees?, %name;, ce:degrees?,
                      ce:ranking?, ce:roles?, ce:cross-ref*,
                      ce:e-address*, ce:link? )>
<!ATTLIST ce:author
  id          ID          #IMPLIED
  role       CDATA      #IMPLIED
  author-id  CDATA      #IMPLIED
  biographyid IDREF     #IMPLIED>
```

#### Model (CEPs 1.1.2–1.1.6)

```
<!ELEMENT ce:author ( ce:initials?, ce:indexed-name?,
                      ce:degrees?, %name;, ce:degrees?,
                      ce:ranking?, ce:roles?, ( %cross-
                      ref; )*, ce:e-address*, ce:link? )>
<!ATTLIST ce:author
  id          ID          #IMPLIED
  role       CDATA      #IMPLIED
  author-id  CDATA      #IMPLIED
  biographyid IDREF     #IMPLIED>
```

### Description

Each author of the item is captured using `ce:author`.

### Usage

The element `ce:author` consists of optional initials, if these cannot be inferred from the first name (`ce:initials`), an optional name under which the author should appear in an index (`ce:indexed-name`), optional degrees (`ce:degrees`), a possible first (given) name (`ce:given-name`) followed or preceded by a surname (family name, `ce:surname`), an optional indication for the generation (`ce:suffix`), more optional degrees (`ce:degrees`), an optional indication of the importance of the author (`ce:ranking`), optionally the roles the author has (`ce:roles`), cross-references to the author's affiliation(s) and to author footnotes (`ce:cross-ref`), a number of electronic addresses of the author (`ce:e-address`), and a link to a picture of the author (`ce:link`).

For more details, see these subelements. A `ce:cross-ref` should refer to a `ce:footnote` in a `ce:author-group` (possibly different from the current one). The surname may precede the first name; the order of these elements within `ce:author` determines the order in which they must be rendered.

The `ce:author` element has an attribute `biographyid` which is used to refer to a biography (`ce:biography`) of the author.

The attribute `id` can be used to link to the author. The attribute `author-id` is meant to contain a unique identification of the author, coming from a central Elsevier author database.

In many cases, it is not clear or it is unknown which part of an author name constitutes the first name and which the surname. In some cultures, people may have just a single name, which is treated as the surname. This may contradict how the author's culture feels about this, but the reason is purely functional: what matters is that an author is indexed under the surname; the first name may be abbreviated in the index or the running heads.

If the author is not a person, e.g. an institution or a government body, `ce:author` is also used, and the name is captured within `ce:surname`. This should not be confused with a named group of scientists, i.e. a collaboration, which is captured using `ce:collaboration`.

*XML*

```
<ce:author>
  <ce:surname>Liszt</ce:surname>
  <ce:given-name>Ferenc</ce:given-name>
</ce:author>
<ce:author>
  <ce:surname>Govinda</ce:surname>
</ce:author>
<ce:author>
  <ce:surname>National Board of Transport Safety</ce:surname>
</ce:author>
```

*XML*

```
<ce:author>
  <ce:degrees>Prof.</ce:degrees>
  <ce:given-name>Elizabeth M.C.</ce:given-name>
  <ce:surname>Square</ce:surname>
  <ce:suffix>Sr.</ce:suffix>
  <ce:degrees>D.Phil. (Oxon)</degrees>
  <ce:ranking>*</ce:ranking>
  <ce:roles>Chair, Royal Commission for Biomedical Research</ce:roles>
  <ce:cross-ref refid="aff1"><ce:sup>a</ce:sup></ce:cross-ref>
  <ce:cross-ref refid="aff5"><ce:sup>e</ce:sup></ce:cross-ref>
  <ce:cross-ref refid="fn2"><ce:sup>2</ce:sup></ce:cross-ref>
  <ce:e-address>emc.square@hotmail.com</ce:e-address>
  <ce:link locator="fx1"/>
</ce:author>
```

If the author is deceased, this cannot be indicated within `ce:author`; a footnote following the author is to be used.

If the author has only supplied initials instead of a full given name, then these are also captured in `ce:given-name`.

*XML*

```
<ce:author>
  <ce:given-name>A.P.</ce:given-name>
  <ce:surname>Ershov</ce:surname>
</ce:author>
```

In order to help applications to render the correct initials from a given name, the element `ce:initials` has been provided. If (and only if) the initials of the author cannot be inferred from the `ce:given-name` element by taking the first letter of each name, preserving dashes, the subelement `ce:initials` is used to capture the author's correct initials. It is used for rendering author names with initials instead of full given names, e.g. in tables of contents and in running heads. Note that `ce:initials` does not replace `ce:given-name`.

*XML*

```
<ce:author biographyid="bio2">
  <ce:initials>Ph.E.</ce:initials>
  <ce:given-name>Philippe E.</ce:given-name>
  <ce:surname>Shepherd</ce:surname>
</ce:author>
```

In order to help applications to correctly alphabetize a name, the element `ce:indexed-name` has been provided. If (and only if) it is common to alphabetize the name at a place which cannot be inferred from the `ce:surname`, the subelement `ce:indexed-name` is used. This is only for very exceptional cases, because it is assumed that indexing programs can cope with all names with accented characters.

*XML*

```
<ce:author>
  <ce:indexed-name>Gamma-Corporation</ce:indexed-name>
  <ce:surname>&Gamma;-Corporation</ce:surname>
</ce:author>
```

The element `ce:link` can be used to add a picture of the author. This should not be confused with a picture of the author within the biography.

## Version history

Prior to DTD 5.0, this element was called `au`; it did not contain the initials or indexed name, cross-references and the electronic addresses at this level. The `author-id` attribute was added in CEP 1.1.0. Parameter entity `%cross-ref;` was introduced in CEP 1.1.2.

## See also

[ce:author-group](#), [ce:collaboration](#)

## ce:author-group

### Declaration

#### Model (CEPs 1.1.0–1.1.5)

```
<!ELEMENT ce:author-group ( ( ce:collaboration | ce:author )+,
                             ce:affiliation*, ce:correspondence*,
                             ce:footnote* )>
```

#### Model (CEP 1.1.6)

```
<!ELEMENT ce:author-group ( ( ce:collaboration | ce:author
                              | ce:text )+, ce:affiliation*,
                              ce:correspondence*, ce:footnote* )>
<!ATTLIST ce:author-group
          role CDATA #IMPLIED>
```

### Description

The element `ce:author-group` contains authors and their affiliations.

### Usage

The element `ce:author-group` is an important part of the head of an item. It contains a group of authors and/or collaborations with associated information. Some document types allow more than one author group; this is needed for implicit author–affiliation couplings (see below).

The element `ce:author-group` is also used in a structured list of editors of an issue, `ce:editors`, to capture a group of editors.

Each author group consists of a sequence of authors (`ce:author`) and/or collaborations (`ce:collaboration`), possibly interspersed with free text (`ce:text`). This is followed by a list of affiliations (`ce:affiliation`), correspondence information (`ce:correspondence`) and footnotes (`ce:footnote`).

The affiliation list contains all the affiliations in this author group. Each author or collaboration may either be coupled to several affiliations, or all authors share the same uncoupled affiliations. The authors and/or collaborations on the one hand and affiliations on the other hand can be related to each other in two ways.

- *Explicit.* The relationship between authors and affiliations is indicated by adding a `ce:cross-ref` element within `ce:author`, referring to an `id` of an affiliation. In this case, authors always require a `ce:cross-ref` to an affiliation; collaborations require an affiliation if there are no authors in the same author group. When using explicit coupling, it is allowed to have affiliations without associated authors or collaborations. It is not allowed to couple an author with an affiliation in another author group.
- *Implicit.* All authors in an author group are related to all affiliations present in that author group. Typically, but not necessarily, there will be only one affiliation in the author group. The authors do not have a `ce:cross-ref` element, and the affiliations do not need a `ce:label` subelement.

Especially for the editors of an issue it may occur that some, or usually all, editors are listed without affiliation. In such a case it is important not to create unnecessary `ce:author-groups`. The following rule must be applied: consecutive authors or editors without an affiliation must be captured in a single `ce:author-group`.

The following example shows *explicit* author–affiliation coupling.

XML

```
<ce:author-group>
  <ce:author biographyid="vt1">
    <ce:given-name>J.J.</ce:given-name>
    <ce:surname>Niemela</ce:surname>
    <ce:ranking>*</ce:ranking>
    <ce:cross-ref refid="aff1"><ce:sup>a</ce:sup></ce:cross-ref>
    <ce:cross-ref refid="fn1"><ce:sup>1</ce:sup></ce:cross-ref>
  </ce:author>
  <ce:author biographyid="vt2">
    <ce:given-name>K.R.</ce:given-name>
    <ce:surname>Sreenivasan</ce:surname>
    <ce:cross-ref refid="aff1"><ce:sup>a</ce:sup></ce:cross-ref>
    <ce:cross-ref refid="aff2"><ce:sup>b</ce:sup></ce:cross-ref>
  </ce:author>
  <ce:author>
    <ce:given-name>R.J.</ce:given-name>
    <ce:surname>Donnelly</ce:surname>
    <ce:cross-ref refid="aff1"><ce:sup>a</ce:sup></ce:cross-ref>
    <ce:cross-ref refid="cor1">&#x0204E;</ce:cross-ref>
    <ce:e-address>russ@vortex.uoregon.edu</ce:e-address>
  </ce:author>
  <ce:affiliation id="aff1">
    <ce:label>a</ce:label>
    <ce:textfn>Cryogenic Helium Turbulence Laboratory,
      Department of Physics, University of Oregon, Eugene, OR
      97403, USA</ce:textfn>
  </ce:affiliation>
  <ce:affiliation id="aff2">
    <ce:label>b</ce:label>
    <ce:textfn>Mason Laboratory, Yale University, New Haven, CT
      06520-8286, USA</ce:textfn>
  </ce:affiliation>
  <ce:correspondence id="cor1">
    <ce:label>&#x0204E;</ce:label>
    <ce:text>Correspondence and requests for materials should be
      addressed to R.J. Donnelly.</ce:text>
  </ce:correspondence>
  <ce:footnote id="fn1">
    <ce:label>1</ce:label>
    <ce:note-para>Supported by NSF Grant ...</ce:note-para>
  </ce:footnote>
</ce:author-group>
```

*Presentation*

J.J. Niemela<sup>\*,a,1</sup>, K.R. Sreenivasan<sup>a,b</sup>, R.J. Donnelly<sup>a,\*</sup>

<sup>a</sup> Cryogenic Helium Turbulence Laboratory, Department of Physics, University of Oregon, Eugene, OR 97403, USA

<sup>b</sup> Mason Laboratory, Yale University, New Haven, CT 06520-8286, USA

⋮

\* Correspondence and requests for materials should be addressed to R.J. Donnelly.

<sup>1</sup> Supported by NSF Grant ...

The following example is an example of *implicit* author–affiliation coupling. Unlike the previous example, there are no labels “a” and “b” that make the coupling explicit. All the authors in the author group belong to the affiliation in this author group.

*XML*

```
<ce:author-group>
  <ce:author>
    <ce:given-name>Akira</ce:given-name>
    <ce:surname>Hirose</ce:surname>
  </ce:author>
  <ce:author>
    <ce:given-name>Hirofumi</ce:given-name>
    <ce:surname>Onishi</ce:surname>
  </ce:author>
  <ce:affiliation>
    <ce:textfn>Research Center for Advanced Science and Technology
      (RCAST), The University of Tokyo, 4-6-1 Komaba, Meguro-ku,
      Tokyo 153, Japan</ce:textfn>
  </ce:affiliation>
</ce:author-group>
```

*Presentation*

Akira Hirose and Hirofumi Onishi

*Research Center for Advanced Science and Technology (RCAST),*

*The University of Tokyo, 4-6-1 Komaba, Meguro-ku, Tokyo 153, Japan*

The element `ce:text` is an elementary way to add text before, in between and after author names.

*XML*

```
<ce:author-group>
  <ce:author>
    <ce:given-name>R.</ce:given-name>
    <ce:surname>Glynn-Jones</ce:surname>
    <ce:cross-ref refid="aff1"><ce:sup>a</ce:sup></ce:cross-ref>
  </ce:author>
  <ce:text>on behalf of the</ce:text>
  <ce:collaboration>
    <ce:text>Colorectal Cancer Annual Consensus Meeting Group</ce:text>
  </ce:collaboration>
  <ce:affiliation>
    <ce:label>a</ce:label>
    <ce:textfn>Mount Vernon Cancer Centre, Rickmansworth Road,
      Northwood HA6 2RN, UK</ce:textfn>
  </ce:affiliation>
</ce:author-group>
```

*Presentation*

R. Glynn Jones<sup>a</sup> on behalf of the Colorectal Cancer Annual Consensus Meeting Group

<sup>a</sup> *Mount Vernon Cancer Centre, Rickmansworth Road, Northwood HA6 2RN, UK*

## Version history

In CEP 1.1.6, subelement `ce:text` was added to the content model and the attribute `role` was added.

## See also

`ce:editors`

## ce:bibliography

### Declaration

#### Model (CEPs 1.1.0–1.1.6)

```
<!ELEMENT ce:bibliography ( ce:section-title, ce:bibliography-sec+ )>
<!ATTLIST ce:bibliography
  id ID #IMPLIED
  role CDATA #IMPLIED
  view %view; 'all'>
```

### Description

The element `ce:bibliography` is used for the reference list of a document.

### Usage

The element `ce:bibliography` contains bibliographic references of the document. It consists of several subsections, `ce:bibliography-sec`. Often there is just one reference list, in which case the bibliography contains only one `ce:bibliography-sec` without a `ce:section-title`. Each `ce:bibliography-sec` except the first must have a `ce:section-title`, for the first this is optional.

The subelement `ce:section-title` of `ce:bibliography` contains the name of the bibliography, e.g. “References” or “Bibliography”.

Each `ce:bibliography-sec` contains one or more bibliographic references, `ce:bib-reference`. Each `ce:bib-reference` must be referred to by means of `ce:cross-ref`. References which are not being referred to, may find a place in the further-reading list, `ce:further-reading`.

### Version history

Prior to DTD 5.0, the element `bibl` contained the bibliographic references. It is comparable to `ce:bibliography-sec`, and `ce:bibliography` is a container of the bibliography sections. The `view` attribute was added in CEP 1.1.0.

### Light reading

`ce:bibliography` is part of HEAD-AND-TAIL material.

### See also

Structured references are explained in more detail in the section [Bibliographic references](#) (p. 394).



## ce:bibliography-sec

### Declaration

#### Model (CEPs 1.1.0–1.1.5)

```
<!ELEMENT ce:bibliography-sec ( ce:section-title?, ce:bib-
reference+ )>
<!ATTLIST ce:bibliography-sec
    id ID #IMPLIED
    role CDATA #IMPLIED>
```

#### Model (CEP 1.1.6)

```
<!ELEMENT ce:bibliography-sec ( ce:section-title?, ce:bib-
reference+ )>
<!ATTLIST ce:bibliography-sec
    id ID #IMPLIED
    role CDATA #IMPLIED
    view %view; 'all'>
```

### Description

The element `ce:bibliography-sec` is a section within the bibliographic references.

### Usage

See `ce:bibliography`.

### Version history

The `view` attribute was added in CEP 1.1.6.

## ce:bib-reference

### Declaration

#### Model (CEPs 1.1.0–1.1.5)

```
<!ELEMENT ce:bib-reference ( ce:label, ( ce:note | ( ( sb:reference
| ce:other-ref )+, ce:note? ) ) )>
<!ATTLIST ce:bib-reference
  id ID #REQUIRED>
```

#### Model (CEP 1.1.6)

```
<!ELEMENT ce:bib-reference ( ce:label, ( ce:note | ( ( sb:reference
| ce:other-ref )+, ce:note? ) ) )>
<!ATTLIST ce:bib-reference
  id ID #REQUIRED
  role CDATA #IMPLIED>
```

### Description

The element `ce:bib-reference` is used to capture a bibliographic reference within the reference list or within the further-reading section.

### Usage

Each entry in a list of bibliographic references (`ce:bibliography`) or a further-reading list (`ce:further-reading`) is a `ce:bib-reference`.

The `ce:bib-reference` may be either just a `ce:note` (an endnote), or a sequence of one or more bibliographic references followed by a `ce:note`. The core of each bibliographic reference is a structured reference (`sb:reference`) or an unstructured reference (`ce:other-ref`).

The `ce:bib-reference` must have an `id` attribute and a `ce:label` subelement. For numbered references, the `ce:label` contains the number (no punctuation is generated by this instance of `ce:label`) and for name/date references it contains name and date in the way the reference is referred to in the text without parentheses. Several possible formats are shown below. Note in particular the full stop in the second example and the “1999a” in the fifth example.

#### XML

```
<ce:bib-reference id="bib37"><ce:label>[37]</ce:label>
<ce:bib-reference id="bib37"><ce:label>37.</ce:label>
<ce:bib-reference id="bib37"><ce:label>[Go78]</ce:label>
<ce:bib-reference id="bib37"><ce:label>Böhm et al., 1999</ce:label>
<ce:bib-reference id="bib37"><ce:label>Böhm et al., 1999a</ce:label>
```

### Name/date references

In case of the name/date referencing style the bibliographic references are printed without a label before the reference, and thus their `ce:label` element is not shown, and may seem irrelevant. However, in name/date references with the same authors and the same year, the “a” and “b” after the year is stored within the `ce:label` element. This is the only place where the “a” or “b” can be found; the `sb:date` does not contain it as it is not a property of the reference but of the document in which the reference appears.

Moreover, some publications may choose to show the `ce:label` element in their presentation. One case in which this happens in almost all applications, is when a reference is one of the targets in a one-to-many cross-reference. In electronic publications such a one-to-many cross-reference may be represented with a “drop-down menu”, which is built up via the `ce:label` elements of the targets (see the section [Cross-references and the label element](#), p. 151).

*XML*

```
<ce:bib-reference id="bib12">
  <ce:label>Sheen, 1999a</ce:label>
  <sb:reference>
    <sb:contribution>
      <sb:authors>
        <sb:author>
          <ce:given-name>J.</ce:given-name>
          <ce:surname>Sheen</ce:surname>
        </sb:author>
      </sb:authors>
      <sb:title>
        <sb:maintitle>C<ce:inf>4</ce:inf> gene expression</sb:maintitle>
      </sb:title>
    </sb:contribution>
    <sb:host>
      <sb:issue>
        <sb:series>
          <sb:title>
            <sb:maintitle>Ann. Rev. Plant Physiol. Plant
              Mol. Biol.</sb:maintitle>
          </sb:title>
          <sb:volume-nr>50</sb:volume-nr>
        </sb:series>
        <sb:date>1999</sb:date>
      </sb:issue>
      <sb:pages>
        <sb:first-page>187</sb:first-page>
        <sb:last-page>217</sb:last-page>
      </sb:pages>
    </sb:host>
  </sb:reference>
</ce:bib-reference>
```

*Presentation*

Sheen, J., 1999a. C<sub>4</sub> gene expression. Ann. Rev. Plant Physiol. Mol. Biol. 50, 187–217.

### Multiple bibliographic references in one `ce:bib-reference` element

It is possible to group more than one bibliographic reference within a `ce:bib-reference` element. These may be a mixed sequence of structured and unstructured references.

When one or more of the references in the `ce:bib-reference` element are cited individually, they *all* need to have a `ce:label` element, and at least the ones cited individually need to have an `id` attribute. When there is a single reference in a `ce:bib-reference` element, this single reference (`sb:reference` or `ce:other-ref`) is not allowed to have a `ce:label` element and an `id` attribute.

For cross-references to a `sb:reference` element, see the section [Cross-references and the](#)

label element (p. 151).

*XML*

```
<ce:bib-reference id="bib1">
  <ce:label>[1]</ce:label>
  <ce:other-ref>
    <ce:textref>H.P. Nilles, Nucl. Phys. B 499 (1997) 3</ce:textref>
  </ce:other-ref>
  <sb:reference>
    <sb:contribution>
      <sb:authors>
        <sb:author>
          <ce:given-name>T.</ce:given-name>
          <ce:surname>Banks</ce:surname>
        </sb:author>
        <sb:author>
          <ce:given-name>M.</ce:given-name>
          <ce:surname>Dine</ce:surname>
        </sb:author>
      </sb:authors>
    </sb:contribution>
    <sb:host>
      <sb:issue>
        <sb:series>
          <sb:title>
            <sb:maintitle>Nucl. Phys. B.</sb:maintitle>
          </sb:title>
          <sb:volume-nr>479</sb:volume-nr>
          <sb:date>1996</sb:date>
        </sb:series>
      </sb:issue>
      <sb:pages>
        <sb:first-page>173</sb:first-page>
      </sb:pages>
    </sb:host>
  </sb:reference>
</ce:bib-reference>
```

*Presentation*

[1] H.P. Nilles, Nucl. Phys. B 499 (1997) 3;  
T. Banks, M. Dine, Nucl. Phys. B 479 (1996) 173.

*XML*

```
<ce:bib-reference id="bib2">
  <ce:label>[2]</ce:label>
  <sb:reference id="bb2a">
    <ce:label>(a)</ce:label>
    <sb:contribution>...
  </sb:reference>
  <ce:other-ref id="or2b"><
    <ce:label>(b)</ce:label>
    <ce:textref>Y. Koide, ...</ce:textref>
  </ce:other-ref>
</ce:bib-reference>
```

*Presentation*

[2] (a) A. Szczepaniak, Phys. Rev. D 54 (1996) 1167;

(b) Y. Koide, Z. Phys. C 71 (1996) 459.

With the name/date referencing style, grouping of several [sb:reference](#) or [ce:other-ref](#) elements is discouraged.

### Version history

Prior to DTD 5.0, this element was called `bib`.

### Light reading

In HEAD-AND-TAIL SGML files, [ce:bib-references](#) need not be referred to.

### Known bugs, hacks and problems

It is not possible to have a comment to a multiple reference.

### See also

Structured references are explained in more detail in the section [Bibliographic references](#) (p. 394). The `role` attribute was added in CEP 1.1.6.

## ce:biography

### Declaration

#### Model (CEPs 1.1.0–1.1.5)

```
<!ELEMENT ce:biography ( ce:link?, ce:simple-para+ )>
<!ATTLIST ce:biography
  id ID #IMPLIED
  view %view; 'all'>
```

#### Model (CEP 1.1.6)

```
<!ELEMENT ce:biography ( ce:link?, ce:simple-para+ )>
<!ATTLIST ce:biography
  id ID #IMPLIED
  role CDATA #IMPLIED
  view %view; 'all'>
```

### Description

Some journals publish short biographies in their articles. The element `ce:biography` is used for this purpose.

### Usage

The biography element `ce:biography` contains a short biography of a person, mostly the author in the form of one or more “simple” paragraphs, `ce:simple-para`. It has an `id`; the link with the author is established through the `biographyid` attribute of `ce:author`. It is also possible to link a name in the text to a `ce:biography` via a `ce:cross-ref`.

If the biography contains a photograph of the author, the first subelement `ce:link` is used to reference the file containing the photograph. It is not appropriate to use `ce:inline-figure` for the photograph.

*XML*

```
<!ENTITY pic1 SYSTEM "fx1" NDATA IMAGE>
...
<ce:biography id="bio1">
  <ce:link locator="pic1"/>
  <ce:simple-para><ce:bold>Stephen Hawking</ce:bold> holds
    the chair once held by Isaac Newton as Lucasian
    Professor in Mathematics at the University of
    Cambridge...</ce:simple-para>
</ce:biography>
```

In some journals or books there are no biographies, but a picture of each author is displayed near the author’s name in the document head. For this, `ce:link` in `ce:author` is used.

### Version history

Prior to DTD 5.0, this element was called `vt`. Then it did not contain the `ce:link` subelement; the graphic file was associated to the biography with an attribute. The `view` attribute was added in CEP 1.1.0. The `role` attribute was added in CEP 1.1.6.

## ce:bold

### Declaration

#### Model (CEPs 1.1.0–1.1.6)

```
<!ELEMENT ce:bold ( %richstring.data; )*>
```

### Description

The element `ce:bold` is a [font changing element](#) (p. 155). It is used to obtain bold.

### Usage

#### XML

```
<ce:bold>This text is in bold</ce:bold>
```

#### Presentation

**This text is in bold**

### Version history

Prior to DTD 5.0, this element was called `b`.

### See also

For more information see the section on [text effects](#) (p. 155). See also [ce:cross-out](#), [ce:italic](#), [ce:monospace](#), [ce:sans-serif](#), [ce:small-caps](#), [ce:underline](#).

## ce:br

### Declaration

#### Model (CEPs 1.1.2–1.1.6)

```
<!ELEMENT ce:br EMPTY>
```

### Description

The element `ce:br` is used to create an explicit line break.

### Usage

If the need arises to indicate an explicit line break `ce:br` can be used within certain context, e.g. within a table cell.

#### XML

```
...
<row>
  <entry>Dairy</entry>
  <entry>8 oz milk<ce:br/>8 oz cottage cheese<ce:br/>8 oz ice
    cream<ce:br/>1 oz hard cheese<ce:br/>1 cup yogurt
  </entry>
  <entry>6 servings per day</entry>
  <entry>8 servings per day</entry>
  <entry>10 servings per day</entry>
  <entry>12 servings per day</entry>
</row>
...
```

#### Presentation

Menu Guidelines					
Food group	Serving size	Singleton	Twins	Triples	Quads
Dairy	8 oz milk 8 oz cottage cheese 8 oz ice cream 1 oz hard cheese 1 cup yogurt	6 servings per day	8 servings per day	10 servings per day	12 servings per day
...					

#### Explanation

The line breaks in the second column are a result of the use of element `ce:br` whereas the line breaks in columns 3–6 are created by the rendering application. Note that in the above XML example the header rows are omitted for brevity.

### Version history

This element was introduced in CEP 1.1.2.



## ce:caption

### Declaration

#### Model (CEPs 1.1.0–1.1.1)

```
<!ELEMENT ce:caption ( ce:simple-para+ )>
```

#### Model (CEPs 1.1.2–1.1.5)

```
<!ELEMENT ce:caption ( ce:simple-para+ )>
<!ATTLIST ce:caption
  role          CDATA          #IMPLIED
  xml:lang      %iso639;      #IMPLIED>
```

#### Model (CEP 1.1.6)

```
<!ELEMENT ce:caption ( ce:simple-para+ )>
<!ATTLIST ce:caption
  id            ID            #IMPLIED
  role          CDATA          #IMPLIED
  xml:lang      %iso639;      #IMPLIED>
```

### Description

Captions are tagged with `ce:caption`.

### Usage

Figures, tables, e-components and textboxes possess captions, structured with `ce:caption`, that give a description of the object. A `ce:caption` consists of one or more simple paragraphs, `ce:simple-para`.

The attribute `xml:lang`, with values in the [ISO 639 set of entities](#) (p. 162), indicates the language of the caption, by default the language of the document. This is to support publications that publish captions in different languages.

The attribute `role` allows one to categorize captions. For instance, it makes it possible to mark a caption as “title” and handle it different from ordinary captions. Applications should treat captions with roles unknown to them as ordinary captions, i.e., unknown roles must be ignored. The role must belong to a list validated by the XML validation tools. The following value for `role` has been defined:

- `title` is used to mark the caption as the title of the figure, table or textbox.

### Version history

The `xml:lang` and `role` attributes were added in CEP 1.1.2. The `id` attribute was added in CEP 1.1.6.

### See also

[ce:alt-e-component](#), [ce:e-component](#), [ce:figure](#), [ce:table](#), [ce:textbox](#)

## ce:chem

### Declaration

#### Model (CEPs 1.1.0–1.1.6)

```
<!ELEMENT ce:chem ( %textfn.data; )*>
```

### Description

A displayed chemical formula is captured using `ce:chem`.

### Usage

The element `ce:chem` is one of the possible subelements of `ce:formula`. It contains the text of the chemical formula to be displayed. The equation number is separately captured in the `ce:label` child element of the `ce:formula` parent.

*XML*

```
<ce:formula id="ch2">
  <ce:label>(2)</ce:label>
  <ce:chem>TLC (CH<ce:inf>2</ce:inf>C<ce:inf>12</ce:inf>/MeOH):
    <ce:it>R</ce:it><ce:inf>f</ce:inf>=0.45; IR:
    3423 cm<ce:sup>-1</ce:sup> (NH).</ce:chem>
</ce:formula>
```

Inline chemical formulae may be entered as part of the running text, without a special tag.

### Version history

Prior to DTD 5.0, both displayed mathematical and displayed chemical formulae were captured in the element `fd`.

### Rendering notes

The content is rendered within the formula area of `ce:formula`, possibly followed by the equation number.

## ce:collab-aff

### Declaration

#### Model (CEPs 1.1.0–1.1.6)

```
<!ELEMENT ce:collab-aff ( %text.data; )*>
```

### Description

The element `ce:collab-aff` adds an affiliation-like phrase to a collaboration.

### Usage

See [ce:collaboration](#).

## ce:collaboration

### Declaration

#### Model (CEPs 1.1.0–1.1.1)

```
<!ELEMENT ce:collaboration ( ce:indexed-name?, ce:text, ce:cross-
                             ref*, ce:collab-aff? )>
<!ATTLIST ce:collaboration
          id          ID          #IMPLIED
          role        CDATA       #IMPLIED>
```

#### Model (CEPs 1.1.2–1.1.6)

```
<!ELEMENT ce:collaboration ( ce:indexed-name?, ce:text, ( %cross-
                             ref; )*, ce:collab-aff? )>
<!ATTLIST ce:collaboration
          id          ID          #IMPLIED
          role        CDATA       #IMPLIED>
```

### Description

The name of a collaboration is captured in the `ce:collaboration` element.

### Usage

A collaboration denotes a group of authors who present themselves under a common name: the collaboration name. The element `ce:collaboration` is used to capture such a collaboration. It contains an optional name under which the collaboration should appear in an index (`ce:indexed-name`), a container for the actual name (`ce:text`), optional cross-references to affiliations or footnotes (`ce:cross-ref`), and an optional collaboration affiliation (`ce:collab-aff`).

#### XML

```
<ce:collaboration>
  <ce:text>ALPHA Collaboration</ce:text>
  <ce:cross-ref refid="fn1"><sup>1</sup></ce:cross-ref>
</ce:collaboration>
...
<ce:footnote id="fn1">
  <ce:label>1</ce:label>
  <ce:note-para>Operated by the Universities of ...</ce:note-para>
</ce:footnote>
```

The collaboration name can be used in an author group `ce:author-group` instead of or in addition to the names of its member authors. A `ce:collaboration` element can be the only element in an author group, or its author group can contain the names of other collaborations and the names of individual authors.

#### XML

```
<ce:author-group>
  <ce:author>
    <ce:given-name>Th.J.</ce:given-name>
    <ce:surname>Jansen</ce:surname>
```

```

</ce:author>
<ce:collaboration>
  <ce:text>The ISOLDE Collaboration</ce:text>
  <ce:collab-aff>Cryogenic Helium Turbulence
    Laboratory ...</ce:collab-aff>
</ce:collaboration>
</ce:author-group>

```

If (and only if) it is common to alphabetize the name at a place which cannot be inferred from the `ce:collaboration`, the subelement `ce:indexed-name` is used. This is only for very exceptional cases, because it is assumed that indexing programs can cope with all names with accented characters.

*XML*

```

<ce:collaboration>
  <ce:indexed-name>Alpha Collaboration</ce:indexed-name>
  <ce:text>&alpha; Collaboration</ce:text>
</ce:collaboration>

```

Sometimes a collaboration adds an affiliation-like phrase to its name. This can be captured in the `ce:collab-aff` element.

*XML*

```

<ce:collaboration>
  <ce:text>ALPHA Collaboration</ce:text>
  <ce:collab-aff>Stockholm&ndash;London&ndash;Amsterdam</ce:collab-aff>
</ce:collaboration>

```

*Presentation*

```

ALPHA Collaboration
Stockholm–London–Amsterdam

```

A collaboration should not be confused with a non-person author (captured using `ce:surname`).

## Version history

Parameter entity `%cross-ref;` was introduced in CEP 1.1.2.

## See also

`ce:author`, `ce:author-group`, `ce:collab-aff`, `ce:indexed-name`

## ce:compound-formula

### Declaration

#### Model (CEPs 1.1.0–1.1.6)

```
<!ELEMENT ce:compound-formula ( %text.data; )*>
```

### Description

The formula of a chemical compound within a stereochemistry abstract is captured using [ce:compound-formula](#).

### Usage

See [ce:stereochem](#).

### Version history

Prior to DTD 5.0, this element was called `compound-f`.

## ce:compound-info

### Declaration

#### Model (CEPs 1.1.0–1.1.6)

```
<!ELEMENT ce:compound-info      ( ce:list-item+ )>
```

### Description

Part of a stereochemistry abstract is additional itemized information about a chemical compound. The element [ce:compound-info](#) provides a way to capture this.

### Usage

See [ce:stereochem](#).

## ce:compound-name

### Declaration

#### Model (CEPs 1.1.0–1.1.6)

```
<!ELEMENT ce:compound-name ( %text.data; )*>
```

### Description

The name of a chemical compound within a stereochemistry abstract is captured using [ce:compound-name](#).

### Usage

See [ce:stereochem](#).



## ce:compound-struct

### Declaration

#### Model (CEPs 1.1.0–1.1.6)

```
<!ELEMENT ce:compound-struct ( ce:link )>
```

### Description

The purpose of the element [ce:compound-struct](#), part of a stereochemistry abstract, is to provide a link to a graphic file showing a chemical structure.

### Usage

See [ce:stereochem](#).

## ce:copyright

### Declaration

#### Model (CEPs 1.1.0–1.1.6)

```
<!ELEMENT ce:copyright ( %string.data; )*>
<!ATTLIST ce:copyright
  type          %copyright-type; #REQUIRED
  year          NMTOKEN          #REQUIRED>
```

### Description

The element `ce:copyright` contains information about the copyright owner of the document, or of a component of the document.

### Usage

The element `ce:copyright` is used to capture the copyright holder and status of an item. As an optional element within `ce:figure`, `ce:textbox` and `ce:e-component`, it can also be used to indicate the copyright holder of such an object.

It has two mandatory attributes, `type` and `year`. The latter contains the copyright year while the former, which takes its values in `%copyright-type;`, contains the copyright status, indicated by the following values (the copyright statuses refer to [20]):

- `crown` is used when the author claims Crown copyright. [Copyright status: 004.]
- `full-transfer`: this value is used when a full transfer to one of the publisher's companies has been received. [Copyright status: 002.]
- `joint` is used when a full transfer has been received for an article in a journal whose copyright is owned jointly by one of the publisher's companies and a society. [Copyright status: 002.]
- `limited-transfer` is used when the author has granted only limited rights; special care must be taken for its production. [Copyright status: 005.]
- `no-transfer` is used when there is an unresolvable copyright problem and the article may not be published (in principle, documents with this copyright status cannot occur). This should not be confused with copyright status 001, when copyright has not yet been transferred. Within `ce:figure`, `ce:textbox` or `ce:e-component` it is used to signal that the object may not appear online. [Copyright status: 007.]
- `other` is used when copyright owner is different from the journal's copyright owner, e.g. the authors or their employing institutions. This copyright type is also used in the `ce:copyright` within a `ce:figure`, `ce:textbox` or `ce:e-component`. [Copyright status: 006.]
- `society` is used when a full transfer has been received for an article in a journal whose copyright is owned by a society. [Copyright status: 002.]
- `unknown`: this value is used when the article may be published but the actual status is unknown. This is, for instance, the case when the copyright transfer form has not yet been received from the author. [Copyright status: 001.]
- `us-gov` is used when the author is a US government employee and will not transfer copyright. [Copyright status: 003.]

The content of `ce:copyright` is the copyright holder. Only if the value of `type` is `copyright`, `no-transfer`, `other`, `unknown` or `us-gov`, may the content be empty.

The presentation of the copyright notice of an article depends on (i) the article's copyright status, (ii) the content of the `ce:copyright` element, and (iii) the base data of the journal or book, in particular its copyright owner. It is explained in full detail in [21]. Some examples are given below.

*XML*

```
<ce:copyright type="full-transfer" year="2003">Elsevier  
  Ireland Ltd</ce:copyright>  
<ce:copyright type="society" year="2003">Society of  
  Cardiology</ce:copyright>  
<ce:copyright type="unknown" year="2003"></ce:copyright>
```

*Presentation*

© 2003 Elsevier Ireland Ltd. All rights reserved.  
© 2003 Society of Cardiology. Published by Elsevier Inc. All rights reserved.  
© 2003 Published by Elsevier B.V.

*Explanation*

Note that in the second example, the publishing company is inferred from the base data, it is not present in the XML file. Moreover, in the third example, the “published by” information is also inferred from the journal base data. The text would be different if the journal's copyright holder is not one of the publisher's companies.

## ce:copyright-line

### Declaration

#### Model (CEPs 1.1.0–1.1.6)

```
<!ELEMENT ce:copyright-line ( %richstring.data; )*>
```

### Description

The element `ce:copyright-line` contains a verbatim text to be used as copyright line.

### Usage

The element `ce:copyright-line` contains verbatim text to be used as copyright line. It is used in output DTDs, generated from the `ce:copyright` element, and in DTDs where the copyright statuses as defined in `ce:copyright` are not (yet) applicable.

*XML*

```
<ce:copyright-line>&copy; 2003 Elsevier B.V.</ce:copyright-line>
```

### Version history

This element was introduced in CEP 1.1.0.

## ce:correspondence

### Declaration

#### Model (CEPs 1.1.0–1.1.6)

```
<!ELEMENT ce:correspondence ( ce:label, ce:text )>
<!ATTLIST ce:correspondence
  id ID #REQUIRED>
```

### Description

The element [ce:correspondence](#) is used to indicate the corresponding author or authors, and possibly the correspondence address.

### Usage

The element [ce:correspondence](#) is used to indicate that each author linked to it is a corresponding author. The link is established through a [ce:cross-ref](#) within [ce:author](#), and it must be the target of at least one such cross-reference. To this end, the element [ce:correspondence](#) has an [id](#) attribute and a [ce:label](#) subelement — the latter contains the symbol displayed at the footnote.

It is also possible to have several corresponding authors, each with their own [id](#) and [ce:label](#) element.

The content can be merely “Corresponding author.” or it can contain the correspondence address, which might differ from the author’s affiliation.

*XML*

```
<ce:correspondence id="cor1">
  <ce:label>&#x0204E;</ce:label>
  <ce:text>Correspondence to: R. Schrauwen, Central Application
    Management, Production, Elsevier, Radarweg 29,
    1043 NX Amsterdam, The Netherlands.
    Tel.: +31 20 4852408; fax: +31 20 4853266.</ce:text>
</ce:correspondence>
```

### See also

[ce:author-group](#)

## ce:cross-out

### Declaration

#### Model (CEPs 1.1.0–1.1.6)

```
<!ELEMENT ce:cross-out ( %richstring.data; )*>
```

### Description

The element `ce:cross-out` is related to the [font changing elements](#) (p. 155). It is used to obtain crossed-out text.

### Usage

To obtain crossed-out (strike-through) text, use `ce:cross-out`.

#### XML

```
<ce:cross-out>This text is crossed-out</ce:cross-out>
```

#### Presentation

~~This text is crossed-out~~

### See also

For more information see the section on [text effects](#) (p. 155). See also [ce:bold](#), [ce:italic](#), [ce:monospace](#), [ce:sans-serif](#), [ce:small-caps](#), [ce:underline](#).

## ce:cross-ref

### Declaration

#### Model (CEPs 1.1.0–1.1.6)

```
<!ELEMENT ce:cross-ref ( %text.data; )*>
<!ATTLIST ce:cross-ref
  refid IDREF #REQUIRED>
```

### Description

Simple cross-references to targets within the same document instance are tagged using `ce:cross-ref`.

### Usage

A cross-reference is a reference to another element in the document instance. The mandatory attribute `refid` contains a valid ID.

#### XML

```
see <ce:cross-ref refid="tbl4">Table 4</ce:cross-ref>
according to <ce:cross-ref refid="enun7">Lemma 1.6</ce:cross-ref>
in (<ce:cross-ref refid="bib37">Smith et al., 1998</ce:cross-ref>)
<ce:cross-ref refid="fn2"><ce:sup>2</ce:sup></ce:cross-ref>
```

#### Presentation

```
see Table 4
according to Lemma 1.6
in (Smith et al., 1998)
2
```

The content of `ce:cross-ref` is popularly referred to as “the text to click on”. In an electronic rendering, clicking on the text immediately leads to the destination. The content is the full designation of the destination, e.g. “Fig. 4” rather than “4”. Presentation, such as superior for a reference to a footnote, is tagged explicitly.

The element `ce:cross-ref` may be empty. This can happen, for instance, in a glossary or index. The rendering application must then provide another way to reach the destination.

### Version history

In DTD 4, the element `cross-ref` allows one-to-many links. The new element `ce:cross-refs` has been introduced for that purpose.

### Rendering notes

Element `ce:cross-ref` has no influence on where its target appears in the paper or online versions. For instance, float placement is arranged using `ce:float-anchor`; where the `ce:cross-ref` that points to the float appears is immaterial.

### Copy edit considerations

It sometimes happens that cross-references, especially to bibliographic references, only appear within artwork. It is then required to change the text, e.g. the figure caption, in such a way that the object can be referred to using `ce:cross-ref`.

**See also**

For more information, see the section [Cross-references and the label element](#) (p. 151), as well as the elements [ce:cross-refs](#), [ce:intra-ref](#), [ce:intra-refs](#), [ce:inter-ref](#), [ce:inter-refs](#).



## ce:cross-refs

### Declaration

#### Model (CEPs 1.1.0–1.1.6)

```
<!ELEMENT ce:cross-refs      ( %text.data; )*>
<!ATTLIST ce:cross-refs
          refid                IDREFS          #REQUIRED>
```

### Description

Extended cross-references to multiple targets within the same document instance are tagged using `ce:cross-refs`.

### Usage

An extended cross-reference is a reference to several other elements in the document instance. The mandatory attribute `refid` contains a list of valid IDs. There must be more than one target; for single targets `ce:cross-ref` is used.

#### XML

```
see <ce:cross-refs refid="tbl4 tbl5">Tables 4 and 5</ce:cross-refs>
see <ce:cross-refs refid="pl2 pl3 pl4">Plates II&ndash;IV</ce:cross-refs>
in <ce:cross-refs refid="bib1 bib2 bib3">[1&ndash;3]</ce:cross-refs>
in (<ce:cross-refs refid="bib19 bib20">Jones, 2001a,b</ce:cross-refs>)
```

#### Presentation

```
see Tables 4 and 5
see Plates II–IV
in [1–3]
in (Jones, 2001a,b)
```

The content is the full designation of the destination, e.g. “Figs. 4 and 5” or “Tables 7–10”. Presentation, such as superior for a reference to a footnote, is tagged explicitly.

Due to the one-to-many nature of `ce:cross-refs`, it is a complicated element. The content of `ce:cross-refs` is popularly referred to as “the text to click on”. When users click on this text, the rendering application may provide the user with a list of the targets that this `ce:cross-refs` points to. An important role is played by the `ce:label` elements of the destinations, that can be used to construct such a list. For more information, see the section [Cross-references and the label element](#) (p. 151).<sup>1</sup>

The element `ce:cross-refs` may be empty. This can happen, for instance, in a glossary or index. The rendering application must then provide another way to reach the destination.

### Version history

In DTD 4, the element `cross-ref` was used for both one-to-one and one-to-many links. The element `ce:cross-ref` now only allows one-to-one links.

1. In XML files used for online rendering, it is possible to convert `ce:cross-refs` to the XLink-compliant `ce:intra-refs`, which already contains the designations of the targets.

## Copy edit considerations

It sometimes happens that cross-references, especially to bibliographic references, only appear within artwork. It is then required to change the text, e.g. the figure caption, in such a way that the object can be referred to using `ce:cross-ref`.

## Rendering notes

This section deals with the *online* rendering of one-to-many links.

Rendering one-to-many links is, of course, cumbersome. In the PDF rendering, the content of `ce:cross-refs` is displayed, and a link to only the first destination is made. In an online rendering, this is inadequate. An important role is played by the `ce:label` element of the target.<sup>2</sup> These labels are used to create a drop-down menu of targets, or they are rendered sequentially in-line.

Since the inline representation is the most popular, we describe it in more detail here.

### XML

```
see Refs. <ce:cross-refs refid="bib7 bib8 bib9 bib10">[7&ndash;10] ☺
</ce:cross-refs> for more information.
```

### Presentation

see Refs. [\[7\]](#), [\[8\]](#), [\[9\]](#), and [\[10\]](#) for more information.

### Explanation

The hyperlinks to the four bibliographic references are *not* created by examining the content of the `ce:cross-refs` element, but by pulling out the content of the `ce:label` elements of the targets. The content of `ce:cross-refs` is in fact a collapsed version of these `ce:labels`.

It is wrong to examine the content of the element `ce:cross-refs` and to build logic for expanding the text. A situation that is not uncommon is that an author refers to five chemical reactions (21)–(25), but that three of them are actually presented on a graphic, say Scheme VII. Since these are not coded in XML, it is impossible to refer to the individual reactions. This is done as follows.

### XML

```
... reactions <ce:cross-refs refid="f21 sc7 f25">(21)&ndash;(25) ☺
</ce:cross-refs> ...
```

### Presentation

... reactions [\(21\)](#), [Scheme VII](#), [\(25\)](#) ...

### Explanation

The `ce:label` elements of the targets lead the reader to the correct destination.

It is difficult to construct a sentence that works well with the content of `ce:cross-refs` as well as with the expansion of all the `ce:labels` of the target objects. For instance, suppose that the text contains “... in Figs. 4(a) and 5(b)–(d) ...” while the labels are “Fig. 4” and “Fig. 5”, then the way described above to construct the online sentence loses crucial information about which subfigures are meant. In such cases the use of `ce:cross-ref` is preferred.

2. Note that this is a simplification, used for brevity. In truth, the section title or other portions of the destination also play a role. This is explained in the section [Cross-references and the label element](#) (p. 151). In this section we talk about the `ce:label` element to explain the general concept.

**See also**

For more information, see the section [Cross-references and the label element](#) (p. 151), as well as the elements [ce:cross-refs](#), [ce:intra-ref](#), [ce:intra-refs](#), [ce:inter-ref](#), [ce:inter-refs](#).

## ce:date-accepted

### Declaration

#### Model (CEPs 1.1.0–1.1.6)

<!ELEMENT	ce:date-accepted	EMPTY>		
<!ATTLIST	ce:date-accepted			
	day	NMTOKEN		#IMPLIED
	month	NMTOKEN		#REQUIRED
	year	NMTOKEN		#REQUIRED>

### Description

The `ce:date-accepted` element is used to capture the acceptance date of the article. It is an optional, empty element within the frontmatter.

### Usage

Three attributes, `day`, `month`, `year` are used to store the day, month and year respectively. The latter two attributes are mandatory. The values are numbers, not padded with zero.

*XML*

```
<ce:date-accepted day="29" month="2" year="2000"/>
```

*Presentation*

Accepted 29 February 2000

*XML*

```
<ce:date-accepted month="8" year="2002"/>
```

*Presentation*

Accepted August 2002

### Version history

In DTDs prior to DTD 5.0, this element was called `acc`.

### See also

[ce:date-received](#), [ce:date-revised](#)

## ce:date-received

### Declaration

#### Model (CEPs 1.1.0–1.1.6)

```
<!ELEMENT ce:date-received EMPTY>
<!ATTLIST ce:date-received
    day NMTOKEN #IMPLIED
    month NMTOKEN #REQUIRED
    year NMTOKEN #REQUIRED>
```

### Description

The `ce:date-received` element is used to capture the received date of the article. It is an optional, empty element within the frontmatter.

### Usage

Three attributes, `day`, `month`, `year` are used to store the day, month and year respectively. The latter two attributes are mandatory. The values are numbers, not padded with zero.

#### XML

```
<ce:date-received day="20" month="5" year="1964"/>
```

#### Presentation

Received 20 May 1964

### Version history

In DTDs prior to DTD 5.0, this element was called `re`.

### See also

[ce:date-accepted](#), [ce:date-revised](#)

## ce:date-revised

### Declaration

#### Model (CEPs 1.1.0–1.1.6)

```
<!ELEMENT ce:date-revised EMPTY>
<!ATTLIST ce:date-revised
    day NMTOKEN #IMPLIED
    month NMTOKEN #REQUIRED
    year NMTOKEN #REQUIRED>
```

### Description

The `ce:date-revised` element is used to capture the revised date(s) of the article, also known as “revised version received” date.

It is an optional, empty element within the frontmatter, where it may occur multiple times.

### Usage

Three attributes, `day`, `month`, `year` are used to store the day, month and year respectively. The latter two attributes are mandatory. The values are numbers, not padded with zero.

#### XML

```
<ce:date-revised day="1" month="4" year="1998"/>
<ce:date-revised day="23" month="11" year="1999"/>
```

#### Presentation

Revised 1 April 1998 and 23 November 1999

#### XML

```
<ce:date-revised day="14" month="7" year="2003"/>
<ce:date-revised day="5" month="4" year="2004"/>
<ce:date-revised day="19" month="4" year="2004"/>
```

#### Presentation

Revised 14 July 2003, 5 April 2004 and 19 April 2004

### Version history

In DTDs prior to DTD 5.0, this element was called `rv`.

### See also

[ce:date-accepted](#), [ce:date-received](#)

## ce:dedication

### Declaration

#### Model (CEPs 1.1.0–1.1.5)

```
<!ELEMENT ce:dedication ( %textfn.data; )*>
```

#### Model (CEP 1.1.6)

```
<!ELEMENT ce:dedication ( %textfn.data; )*>
<!ATTLIST ce:dedication
  role          CDATA          #IMPLIED>
```

### Description

A dedication within the head of an article is captured using `ce:dedication`.

### Usage

The element `ce:dedication` is an optional subelement of the head of a document. It contains the full text of a dedication.

*XML*

```
<ce:dedication>Dedicated to Professor C. Böhm on the occasion
of his 60th birthday.</ce:dedication>
```

### Version history

Prior to DTD 5.0, this element was called `ded`. The `role` attribute was added in CEP 1.1.6.

### Rendering notes

The text “Dedicated to” is not generated.

## ce:def-description

### Declaration

#### Model (CEPs 1.1.0–1.1.6)

```
<!ELEMENT ce:def-description ( ce:para+ )>
```

### Description

The element [ce:def-description](#) is used to capture the description within an entry in a [ce:def-list](#).

### Usage

See [ce:def-list](#).

### Version history

Prior to DTD 5.0, this element was called dd.



## ce:def-list

### Declaration

#### Model (CEPs 1.1.0–1.1.5)

```
<!ELEMENT ce:def-list          ( ce:label?, ce:section-title?,
                                ce:def-term, ce:def-description? )+ >
<!ATTLIST ce:def-list
  id          ID          #IMPLIED>
```

#### Model (CEP 1.1.6)

```
<!ELEMENT ce:def-list          ( ce:label?, ce:section-title?,
                                ce:def-term, ce:def-description? )+ >
<!ATTLIST ce:def-list
  id          ID          #IMPLIED
  role       CDATA       #IMPLIED>
```

### Description

The element `ce:def-list` contains a list of terms and definitions.

### Usage

The element `ce:def-list`, definition list, is modeled after HTML's DL. Its purpose is to capture terms and definitions.

A definition list has an optional label (`ce:label`) and an optional title (`ce:section-title`). It has an optional `id` attribute so that it can become the target of cross-references.

The list itself is a sequence of definition terms, `ce:def-term`, and optional definition descriptions, `ce:def-description`, which consist of one or more paragraphs, `ce:para`. The `ce:def-term` may possess an `id` so that it can be referred to, but due to the efforts needed to create these cross-references, this seldom happens in practice.

If used to capture terms and definitions, as in `ce:nomenclature`, the term is always contained in the `ce:def-term` immediately preceding the `ce:def-description`.

### Version history

Prior to DTD 5.0, this element was called dl. The `role` attribute was added in CEP 1.1.6.

### See also

[ce:list](#), [ce:nomenclature](#)

## ce:def-term

### Declaration

#### Model (CEPs 1.1.0–1.1.6)

```
<!ELEMENT ce:def-term ( %text.data; )*>
<!ATTLIST ce:def-term
            id ID #IMPLIED>
```

### Description

The element [ce:def-term](#) is used to capture the term defined or explained in an entry of a [ce:def-list](#).

### Usage

See [ce:def-list](#).

### Version history

Prior to DTD 5.0, this element was called `dt`.

## ce:degrees

### Declaration

#### Model (CEPs 1.1.0–1.1.6)

```
<!ELEMENT ce:degrees ( %richstring.data; )*>
```

### Description

Titles before or after an author name are captured using `ce:degrees`.

### Usage

The element `ce:degrees` is used for academic degrees, titles of nobility or dignity, military or police ranks, etc. It may occur before and/or after the name.

*XML*

```
<ce:degrees>Prof. Dr. Ing.</ce:degrees>
<ce:given-name>Wolfgang</ce:given-name>
<ce:surname>Böhm</ce:surname>
```

*XML*

```
<ce:degrees>Sir</ce:degrees>
<ce:given-name>Michael</ce:given-name>
<ce:surname>Attiya</ce:surname>
<ce:degrees>Ph.D. (Oxon), KBE, FRCS</ce:degrees>
```

*XML*

```
<ce:degrees>Captain</ce:degrees>
<ce:given-name>Jean-Luc</ce:given-name>
<ce:surname>Picard</ce:surname>
```

*XML*

```
<ce:given-name>Patricia D.</ce:given-name>
<ce:surname>Smith</ce:surname>
<ce:degrees>(Mrs.)</ce:degrees>
```

*Presentation*

```
Prof. Dr. Ing. Wolfgang Böhm
Sir Michael Attiya, Ph.D. (Oxon), KBE, FRCS
Captain Jean-Luc Picard
Patricia D. Smith (Mrs.)
```

The element should not be confused with `ce:suffix` or `ce:roles`.

### Rendering notes

The second `ce:degrees` generates a comma, unless it begins with a parenthesis.

### Version history

Prior to DTD 5.0, this element was called `degs`.

### See also

[ce:author](#), [ce:suffix](#), [ce:roles](#)

## ce:display

### Declaration

#### Model (CEPs 1.1.0–1.1.6)

```
<!ELEMENT ce:display ( ce:figure | ce:table | ce:textbox |  
                      ce:e-component | ce:formula )>
```

### Description

The element [ce:display](#) is a container element for displayed figures, tables, textboxes, e-components and formulae.

### Usage

To indicate that a figure, table, textbox, e-component or formula is “displayed”—which means that it must appear free-standing with white space above and below at the exact position where the element occurs in the document—it should be embedded in a [ce:display](#) element.

### See also

[ce:e-component](#), [ce:figure](#), [ce:table](#), [ce:formula](#), [ce:textbox](#)

## ce:displayed-quote

### Declaration

#### Model (CEPs 1.1.0–1.1.6)

```
<!ELEMENT ce:displayed-quote ( ce:simple-para+ )>
<!ATTLIST ce:displayed-quote
  id ID #IMPLIED
  role CDATA #IMPLIED>
```

### Description

The element `ce:displayed-quote` is used to capture displayed quotes.

### Usage

Displayed quotes are pieces of text, mostly but not necessarily quotations, often presented with a certain indent and some white space above and below. They contain one or more simple paragraphs, `ce:simple-para`.

*XML*

```
<ce:displayed-quote>
  <ce:simple-para>&ldquo;Everything has a version number&rdquo; and
    &ldquo;Who is in the dark, should switch on the light&rdquo;
    are CAM mottos.</ce:simple-para>
</ce:displayed-quote>
```

The attribute `role` allows one to categorize displayed quotes. For instance, it makes it possible to mark “poetry” displayed quotes, and handle these in different ways than ordinary displayed quotes. Applications should treat displayed quotes with roles unknown to them as ordinary displayed quotes, i.e., unknown roles must be ignored. The role must belong to a list validated by the XML validation tools. The following value for `role` has been defined:

- poetry signals that the `ce:displayed-quote` contains a table which is used for the stanza of a poem, and that the rows should be printed with the normal line distance.

*XML*

```
<ce:displayed-quote role="poetry">
  <ce:simple-para><ce:display>
    <ce:table rowsep="0" colsep="0">
      <tgroup cols="1">
        <colspec colname="col1"/>
        <tbody>
          <row><entry>Just before our love got lost you said</entry></row>
          <row><entry>I am as constant as a northern star</entry></row>
          <row><entry>And I said, constant in the darkness</entry></row>
          <row><entry>Where's that at?</entry></row>
          <row><entry>If you want me I'll be in the bar</entry></row>
        </tbody>
      </tgroup>
    </ce:table>
  </ce:display><ce:display>
```

```

<ce:table rowsep="0" colsep="0">
  <tgroup cols="1">
    <colspec colname="col1"/>
    <tbody>
<row><entry>On the back of a cartoon coaster</entry></row>
<row><entry>In the blue tv screen light</entry></row>
<row><entry>I drew a map of Canada</entry></row>
<row><entry>Oh Canada</entry></row>
<row><entry>And your face sketched on it twice</entry></row>
    </tbody>
  </tgroup>
</ce:table>
</ce:display></ce:simple-para>
</ce:displayed-quote>

```

*Presentation*

Just before our love got lost you said  
 I am as constant as a northern star  
 And I said, constant in the darkness  
 Where's that at?  
 If you want me I'll be in the bar

On the back of a cartoon coaster  
 In the blue tv screen light  
 I drew a map of Canada  
 Oh Canada  
 And your face sketched on it twice

**Version history**

Prior to DTD 5.0, this element was called qd.

**Light reading**

[ce:displayed-quote](#) may not be used in CONTENTS-ENTRY-ONLY, HEAD-ONLY or HEAD-AND-TAIL files.

**See also**

[ce:textbox](#) (for pull-quotes)

## ce:dochead

### Declaration

#### Model (CEPs 1.1.0–1.1.6)

```
<!ELEMENT ce:dochead ( ce:textfn, ce:dochead? )>
```

### Description

The element `ce:dochead` contains the document heading or article type of the article.

### Usage

A document heading or article type usually appears above the title. There is a wide variety of examples, such as “Short Communication”, “Erratum”, “Fundamental Study”. Such headings are captured using `ce:dochead`.

*XML*

```
<ce:dochead>
  <ce:textfn>Short Communication</ce:textfn>
</ce:dochead>
```

It is possible to nest a `ce:dochead` to obtain a second-order document heading. It is not allowed to nest deeper.

Although usually items with the same `ce:dochead` are grouped in a table of contents under a similar heading, e.g. “Short communications”, this heading must not be inferred from the document headings of the items. The `ce:dochead` is only used to display a document heading above the title.

Some article types contain a `ce:dochead` but no `ce:title`.

### Light reading

The `ce:dochead` appears also in HEAD-ONLY and HEAD-AND-TAIL as well as in CONTENTS-ENTRY-ONLY files.

### See also

[ce:doctopics](#)

## ce:doctopic

### Declaration

#### Model (CEPs 1.1.0–1.1.6)

```
<!ELEMENT ce:doctopic          ( ce:text, ce:doctopic? )>
<!ATTLIST ce:doctopic
          role                    CDATA          #IMPLIED>
```

### Description

The element `ce:doctopic` contains a topic in a topic hierarchy.

### Usage

See [ce:doctopics](#).



## ce:doctopics

### Declaration

#### Model (CEPs 1.1.0–1.1.6)

```
<!ELEMENT ce:doctopics ( ce:doctopic+ )>
```

### Description

The element `ce:doctopics` is used to associate an item with one or more topic hierarchies.

### Usage

The table of contents of a book or journal issue is only one way to list the items it consists of. It is contained in a file structured according to a books DTD or content-transport schema. For instance, the proceedings of a large conference may be published in the order of the presentations at that conference. Besides this, it may be useful to associate the item with one or more topic hierarchies, in order to group items of the same scientific relevance. These hierarchies provide other ways to gain access to the items of a book or journal issue; in a sense tables of content different from the one that represents the physical publication can be generated from the topic hierarchies.









For instance, a proceedings about document structuring, whose articles appear in the order of the time when the presentations were given, might contain articles about “XML”, “SGML”, etc., and within the first category, articles about “XML schemas”, “Schematron”, “Relax NG”; but the proceedings might have another division depending on whether the article concerns theoretical aspects, practical aspects or actual implementations in software. The following example illustrates this.

#### XML

```
<ce:doctopics>
  <ce:doctopic role="languages">
    <ce:text>XML</ce:text>
  </ce:doctopic>
  <ce:doctopic>
    <ce:text>XML schemas</ce:text>
  </ce:doctopic>
  <ce:doctopic role="theory and practice">
    <ce:text>Parsers</ce:text>
  </ce:doctopic>
</ce:doctopics>
```

#### Presentation

This would generate no output for the item itself, but the item, entitled “An editing tool based on schemas” might appear thus in an online rendering of the topic hierarchy, which resembles a common directory structure:

- ⊕  SGML
- ⊖  XML
  - ⊕  Relax NG
  - ⊕  Schematron
  - ⊖  XML Schemas
    - ⊕  An editing tool based on schemas
    - ⊕  Practical schema design
    - ⊕  Schemas for DTDs

All articles with equal topic hierarchy end up in the same leaf node of the hierarchy.

The optional attribute `role` can be used to name topic hierarchies.

Keywords and classification codes, captured with `ce:keywords` are another way to apply structure to a collection of items. Keywords are mostly designed to ease searching, and typically apply to documents that may occur in many different products. For instance, the mathematics subject classification applies to items of many different journals as well as to books and book chapters. The topic hierarchies, however, are meant mostly for creating alternative tables of content depending on criteria of, say, one certain multi-volume book project.

## See also

[ce:dochead](#), [ce:keywords](#)

## ce:document-thread

### Declaration

#### Model (CEPs 1.1.0–1.1.6)

```
<!ELEMENT ce:document-thread ( ce:refers-to-document+ )>
```

### Description

The element `ce:document-thread` contains a sequence of document identifiers related to the item.

### Usage

A document thread consists of one or more references to other items, captured with element `ce:refers-to-document`.

It is used, for instance, to link an erratum to the original document. An online application can then create a link from the erratum to the original document and, perhaps more importantly, a link from the original document to the erratum.

Discussion threads can be quite complex: In a discussion thread of five documents, the documents could refer to the first one (except the first one itself of course) while the fifth document could also refer to the second and fourth document. An online application could then generate all the links as described in the previous paragraph (12 in total).

#### XML

```
<ce:document-thread>
  <ce:refers-to-document>
    <ce:pII>S0165-0114(04)00081-8</ce:pII>
    <ce:doi>10.1016/j.fss.2004.02.012</ce:doi>
  </ce:refers-to-document>
  <ce:refers-to-document>
    <ce:pII>S0165-0114(02)00276-2</ce:pII>
    <ce:doi>10.1016/S0165-0114(02)00276-2</ce:doi>
  </ce:refers-to-document>
</ce:document-thread>
```

### Version history

This element was introduced in CEP 1.1.0 and replaced `ce:article-thread`.

### See also

[ce:refers-to-document](#)

## ce:doi

### Declaration

#### Model (CEPs 1.1.0–1.1.6)

```
<!ELEMENT ce:doi ( %string.data; )*>
```

### Description

The element `ce:doi` contains the DOI of the item.

### Usage

Each item can have a DOI, a *digital object identifier*, see <http://www.doi.org>. To identify the document, `ce:doi` is populated with the DOI of the document.

The DOI co-exists beside the PII. An item can have a PII, but not a DOI, for instance if the journal does not have an online appearance.

The DOI of a bibliographic reference can also be captured with `ce:doi`.

*XML*

```
<ce:doi>10.1016/j.sedgeo.2003.11.025</ce:doi>
```

*Presentation*

```
doi:10.1016/j.sedgeo.2003.11.025
```

*XML*

```
<ce:bib-reference id="b111">
  <ce:label>Lesch, 2004</ce:label>
  <sb:reference>
    ....
    <sb:host>
      ...
      <ce:doi>10.1016/j.compag.2004.11.004</ce:doi>
    </sb:host>
  </sb:reference>
</ce:bib-reference>
```

*Presentation*

```
Lesch, S.M., 2004. Sensor-directed spatial response sampling designs for characterizing
spatial variation of soil properties. Comp. Electron. Agric., doi:10.1016/j.compag.2004.11.004.
```

### Rendering notes

The text “doi:” is never present in `ce:doi`. However, a DOI is always published with the text “doi:” before it.

### See also

[aid](#), [jid](#), [ce:pri](#)

## ce:e-address

### Declaration

#### Model (CEPs 1.1.0–1.1.6)

```
<!ELEMENT ce:e-address ( %text.data; )*>
<!ATTLIST ce:e-address
  type %e-address-type; "email">
```

### Description

The purpose of the [ce:e-address](#) element is to capture the electronic address(es) of the authors of the document.

### Usage

Each author can have zero or more electronic addresses which are tagged using [ce:e-address](#). The attribute [type](#) denotes the type of the electronic address. Its two values (collected in [%e-address-type](#);) are `email` and `url`. `email`, the default value, is an email address, and `url` is a complete URL, beginning with `http://`.

#### XML

```
<ce:e-address>g.thooft@phys.uu.nl</ce:e-address>
<ce:e-address type="url">http://www.phys.uu.nl/~thooft</ce:e-address>
```

Character entities are not allowed in the content of [ce:e-address](#) with the exception of [&amp](#); (used for an ampersand within a URL).

### Version history

Prior to DTD 5.0, this element was called `ead`.

### See also

[ce:author](#)

## ce:e-component

### Declaration

#### Model (CEPs 1.1.0–1.1.1)

```
<!ELEMENT ce:e-component ( ce:label?, ce:caption?, ce:copyright?,
( ( ce:link, ce:alt-e-component? ) |
ce:e-component )+ )>
<!ATTLIST ce:e-component
id ID #IMPLIED>
```

#### Model (CEP 1.1.2)

```
<!ELEMENT ce:e-component ( ce:label?, ce:caption*, ( %copy-
right; )?, ( ( ce:link, ce:alt-e-
component? ) | ce:e-component )+ )>
<!ATTLIST ce:e-component
id ID #IMPLIED>
```

#### Model (CEPs 1.1.3, 1.1.4)

```
<!ELEMENT ce:e-component ( ce:label?, ce:caption*, ce:source?,
( %copyright; )?, ( ( ce:link, ce:alt-
e-component? ) | ce:e-component )+ )>
<!ATTLIST ce:e-component
id ID #IMPLIED>
```

#### Model (CEPs 1.1.5, 1.1.6)

```
<!ELEMENT ce:e-component ( ce:label?, ce:caption*, ce:source?,
( %copyright; )?, ( ( ce:link, ce:alt-
e-component? ) | ce:e-component )+ )>
<!ATTLIST ce:e-component
id ID #IMPLIED
role CDATA #IMPLIED>
```

### Description

Electronic components are objects such as applets and video and audio sources, spreadsheets, etc., as well as images that do not satisfy the CAP requirements for [ce:figure](#). The element [ce:e-component](#) is provided for this purpose.

### Usage

The element [ce:e-component](#), short for electronic component, contains objects that exist in electronic form, and need to be presented to the reader of an electronic rendition of the document. The element has an optional subelement [ce:alt-e-component](#) which is used instead in media that cannot handle the electronic component, e.g. in print or in a web PDF file. Below we call these media “non-electronic media” and it is worth remembering that that includes the web PDF file.

Electronic components should not be confused with “views”, see [Views](#) (p. 163).

## XML structure of an electronic component

As for other cases where `ce:link` is used, the type of destination can be inferred from the entity's declaration. For a `ce:e-component`, NDATA types APPLICATION, AUDIO, VIDEO and XML can appear—these are exclusively used in `ce:e-component`. The NDATA type IMAGE can also appear, this is used for “Non-CAP” artwork, i.e., artwork meant for online display not satisfying the CAP artwork specifications.

The `ce:e-component` can be “floating” or “displayed”. While the distinction “floating” and “display” may make little difference in most online representations, it does for the embedded `ce:alt-e-component`.

A *displayed* e-component is contained in a `ce:display` element. In an electronic rendering, the displayed e-component should appear at the position where the `ce:display` occurs. What this means for each e-component type (e.g., audio) is up to the application. Non-electronic media display the embedded `ce:alt-e-component` instead, as if it were a displayed figure, see below.

A *floating* e-component is contained within `ce:floats`. A `ce:float-anchor` appears in the text, and acts as an anchor near to which the e-component should appear. Each floating e-component must have exactly one `ce:float-anchor`. Non-electronic media render the embedded `ce:alt-e-component` instead, as if it were a floating figure, see below.

The subelement `ce:label` contains the name or label of the electronic component. The caption (`ce:caption`), consisting of one or more paragraphs (`ce:simple-para`), contains descriptive text about the e-component. There can be multiple captions for different roles and/or languages; each caption must have a different role or language.

The optional subelement `ce:source` is used to describe the source of the figure. The optional `ce:copyright` element can be used if the copyright owner differs from the article's copyright owner.

The attribute `role` is used to indicate the role or alternative presentation style of the e-component.

## Alternative e-component

An optional `ce:alt-e-component` can be included in the e-component. This contains a `ce:link` to an object that is suitable for presentation in non-electronic media. For example, a significant frame (still image) from a video is an example of content of the alternative e-component.

Each `ce:alt-e-component` should be treated exactly like a `ce:figure`. All rules for figures apply. If the e-component is floating or displayed, the `ce:alt-e-component` will behave like a floating or displayed figure, respectively. Its label is the `ce:label` of the parent e-component, and its caption is the `ce:alt-e-component`'s own caption. If the caption is absent this means that the alternative e-component has no caption; it does not mean that the parent's caption should be used.

Quite the opposite situation occurs if `ce:alt-e-component` is *not* encountered within a certain e-component in *non*-electronic media. It is up to the document's style to decide what to do with the e-component in such a situation; the default is to ignore the e-component altogether, another style might print a list of e-component captions.

### Cross-referencing and nesting

The attribute `id` can be the target of a cross-reference or of a link from a foreign document. The `ce:e-component` can be, but does not have to be, referred to from within the text.

If a cross-reference is made to the `ce:e-component`, it must have an embedded `ce:alt-e-component`.

The element `ce:e-component` may be nested; this is mainly to be able to furnish each subcomponent with its own caption. The rules are identical to the rules for `ce:figure`. Within a nested `ce:e-component` it is not allowed to nest further `ce:e-components`.

### Background

The element `ce:e-component` behaves much like `ce:figure` and `ce:textbox`. It is important to realize the implication of this. In HTML, the external files might well be referenced *directly*, i.e. they are accessed via the A element, e.g.

```
for more detail, see CNN's <A HREF="korea.mpg">report of
President Kim Dae-jung's visit to North-Korea</A>..
```

In XML files the element `ce:inter-ref` — the counterpart of HTML's A element — are *not* used to access external files belonging to the document. Instead, these files are accessed through the `ce:link` element embedded in `ce:figure`, `ce:e-component`, etc., and cross-references within the document are made using `ce:cross-ref`.

XML

```
<!ENTITY korea SYSTEM "korea" NDATA VIDEO>
<!ENTITY korea-f SYSTEM "korea-frame" NDATA IMAGE>
...
for more detail, see CNN's <ce:cross-ref refid="ec1">report
of President Kim Dae-jung's visit to North-Korea</ce:cross-ref>.
<ce:e-component id="ec1">
  <ce:label>Video 1</ce:label>
  <ce:caption>
    <ce:simple-para>Coverage of South-Korean President Kim
    Dae-jung's historic visit to North-Korea and welcome by
    Dear Leader Kim Jong-il on Pyongyang International
    Airport.</ce:simple-para>
  </ce:caption>
  <ce:copyright type="other" year="2000">CNN</ce:copyright>
  <ce:link locator="korea"/>
  <ce:alt-e-component>
    <ce:link locator="korea-f"/>
  </ce:alt-e-component>
</ce:e-component>
```

### Version history

Prior to DTD 5.0, the element `upi` existed. It had a different purpose: the `ce:e-component` is specifically for electronic components such as audio and video clips and spreadsheets, etc., whereas `upi` could contain *any* object that should not appear in print (hence the name, unprinted item). The `ce:e-component` *can* appear in print — the `ce:alt-e-component` is shown instead.

In order to create portions of text, which may include figures, tables or electronic components, that should only appear in certain renditions of the document, the `view` attribute of various elements can be used, see [Views](#) (p. 163).



In CEP 1.1.0 a list of subelements `ce:link` and `ce:e-component` became possible. As from CEP 1.1.2, the caption has become repeatable for different languages and roles. Parameter entity `%copyright;` was introduced as well. Subelement `ce:source` was introduced in CEP 1.1.3.

The attribute `role` was added in CEP 1.1.5.

## ce:edition

### Declaration

#### Model (CEPs 1.1.2–1.1.6)

```
<!ELEMENT ce:edition ( %string.data; )*>
```

### Description

`ce:edition` contains the edition of an item.

### Usage

The element `ce:edition` is used to capture the text that describes the edition of an item. The text contains no closing punctuation.

*XML*

```
<ce:edition>Fourth edition</ce:edition>
```

### Version history

This element was introduced in CEP 1.1.2.

## ce:editors

### Declaration

#### Model (CEPs 1.1.2–1.1.5)

```
<!ELEMENT ce:editors ( ce:author-group+ )>
```

#### Model (CEP 1.1.6)

```
<!ELEMENT ce:editors ( ce:author-group+ )>
<!ATTLIST ce:editors
  role CDATA #IMPLIED>
```

### Description

The element `ce:editors` is a container element that is used for capturing the editors and their affiliations.

### Usage

If the need arises to capture the names, degrees, affiliations of editors, the `ce:editors` container element is used, that consists of one or more `ce:author-group` elements. Within this container, the editor names and affiliations are captured as if they were authors. The fact that the `ce:author-group` elements are contained within `ce:editors` indicates that the persons, institutions or collaborations captured with `ce:author` or `ce:collaboration` are editors. In other words, the container element `ce:editors` gives the instruction “for author, read editor”.

All the rules for `ce:author-group` apply, including the rules for implicit and explicit couplings with the affiliations.

*XML*

```
<ce:editors>
  <ce:author-group>
    <ce:text>Edited by</ce:text>
    <ce:author>
      <ce:given-name>Jerald P.</ce:given-name>
      <ce:surname>Kuhn</ce:surname>
      <ce:degrees>M.D.</ce:degrees>
    </ce:author>
    ...
  </ce:author-group>
</ce:editors>
```

### Version history

This element was introduced in CEP 1.1.2. The `role` attribute was added in CEP 1.1.6.

## ce:enunciation

### Declaration

#### Model (CEPs 1.1.0–1.1.6)

```
<!ELEMENT ce:enunciation      ( ce:label, ce:section-title?,
                                ce:para+ )>
<!ATTLIST ce:enunciation
            id             ID             #IMPLIED
            role          CDATA          #IMPLIED>
```

### Description

The element `ce:enunciation` is used to capture enunciations. Enunciations is the catch-all phrase given to the category of structure elements that occur frequently in, e.g., mathematical papers: theorems, lemmas, propositions, proofs, corollaries, definitions, remarks, etc. However, enunciations are not restricted to mathematics.

### Usage

The element `ce:enunciation` consists of a mandatory `ce:label` element, an optional title `ce:section-title` and one or more paragraphs. The `ce:enunciation` can be cross-referenced and therefore has an `id` attribute.

The `ce:label` contains the full designation of the enunciation, e.g. “Lemma 1.6” or “Remark”. The `ce:section-title` is used to capture additional information, e.g. “Fermat’s Theorem”.

#### XML

```
<ce:enunciation id="enun37">
  <ce:label>Theorem 1.12</ce:label>
  <ce:para id="p1">
    <ce:italic>Let</ce:italic>
    <mml:math altimg="si301.gif">
      <mml:mrow>
        <mml:mi>V</mml:mi>
      </mml:mrow>
    </mml:math>
    <ce:italic>be a set. Then the cardinality
      of the powerset of</ce:italic>
    <mml:math altimg="si302.gif">
      <mml:mrow>
        <mml:mi>V</mml:mi>
      </mml:mrow>
    </mml:math>,
    <mml:math altimg="si303.gif">
      <mml:mrow>
        <mml:mi mathvariant="script">P</mml:mi>
        <mml:mo stretchy="false">(</mml:mo>
        <mml:mi>V</mml:mi>
        <mml:mo stretchy="false">)</mml:mo>
      </mml:mrow>
    </mml:math>
  </ce:para>
</ce:enunciation>
```

```

</mml:math>,
<ce:italic>is strictly greater than the cardinality of</ce:italic>
<mml:math altimg="si304.gif">
  <mml:mrow>
    <mml:mi>V</mml:mi>
  </mml:mrow>
</mml:math>.
</ce:para>
</ce:enunciation>
<ce:enunciation id="enun37proof">
  <ce:label>Proof</ce:label>
  <ce:para id="p2">
    Suppose not, and
    <mml:math altimg="si305.gif">
      <mml:mrow>
        <mml:mi>V</mml:mi>
        <mml:mo>&ne;</mml:mo>
        <mml:mi>&empty;</mml:mi>
      </mml:mrow>
    </mml:math>
    (for
    <mml:math altimg="si306.gif">
      <mml:mrow>
        <mml:mi>V</mml:mi>
        <mml:mo>=</mml:mo>
        <mml:mi>&empty;</mml:mi>
      </mml:mrow>
    </mml:math>
    the theorem is clear). Then there is a bijective mapping
    <mml:math altimg="si307.gif">
      <mml:mrow>
        <mml:mi>f</mml:mi>
        <mml:mo>:</mml:mo>
        <mml:mi>V</mml:mi>
        <mml:mo>&rarr;</mml:mo>
        <mml:mi mathvariant="script">P</mml:mi>
        <mml:mo stretchy="false">(</mml:mo>
        <mml:mi>V</mml:mi>
        <mml:mo stretchy="false">)</mml:mo>
      </mml:mrow>
    </mml:math>
    Let
    <mml:math altimg="si308.gif">
      <mml:mrow>
        <mml:mi>a</mml:mi>
        <mml:mo>=</mml:mo>
        <mml:msup>
          <mml:mi>f</mml:mi>
          <mml:mrow>
            <mml:mo>-</mml:mo>
            <mml:mn>1</mml:mn>
          </mml:mrow>
        </mml:msup>
        <mml:mo stretchy="false">(</mml:mo>

```

```

<mml:mo stretchy="false"></mml:mo>
<mml:mi>x</mml:mi>
<mml:mo>&isin;</mml:mo>
<mml:mi>V</mml:mi>
<mml:mo stretchy="false">|</mml:mo>
<mml:mi>x</mml:mi>
<mml:mo>&notin;</mml:mo>
<mml:mi>f</mml:mi>
<mml:mo stretchy="false"></mml:mo>
<mml:mi>x</mml:mi>
<mml:mo stretchy="false"></mml:mo>
<mml:mo stretchy="false"></mml:mo>
<mml:mo stretchy="false"></mml:mo>
</mml:mrow>
</mml:math>.
Then
<mml:math altimg="si309.gif">
  <mml:mrow>
    <mml:mi>a</mml:mi>
    <mml:mo>&isin;</mml:mo>
    <mml:mi>f</mml:mi>
    <mml:mo stretchy="false"></mml:mo>
    <mml:mi>a</mml:mi>
    <mml:mo stretchy="false"></mml:mo>
    <mml:mo>&LeftRightArrow;</mml:mo>
    <mml:mi>a</mml:mi>
    <mml:mo>&notin;</mml:mo>
    <mml:mi>f</mml:mi>
    <mml:mo stretchy="false"></mml:mo>
    <mml:mi>a</mml:mi>
    <mml:mo stretchy="false"></mml:mo>
  </mml:mrow>
</mml:math>. Contradiction.<ce:hsp/>&sq;
</ce:para>
</ce:enunciation>

```

*Presentation*

**Theorem 1.12.** *Let  $V$  be a set. Then the cardinality of the powerset of  $V$ ,  $\mathcal{P}(V)$ , is strictly greater than the cardinality of  $V$ .*

**Proof.** Suppose not, and  $V \neq \emptyset$  (for  $V = \emptyset$  the theorem is clear). Then there is a bijective mapping  $f : V \rightarrow \mathcal{P}(V)$ . Let  $a = f^{-1}(\{x \in V \mid x \notin f(x)\})$ . Then  $a \in f(a) \Leftrightarrow a \notin f(a)$ . Contradiction.  $\square$

*Explanation*

Note that in this example certain spaces are “generated” by the XML. For instance, the space between “*Let*” and “*V*” is generated by the whitespace characters between `</ce:italic>` and `<mml:math altimg="si301.gif">`. See also the section [Whitespace in the XML file](#) (p. 12).

*XML*

```

<ce:enunciation id="25">
  <ce:label>Theorem 1.25</ce:label>
  <ce:section-title>Pythagoras' Theorem</ce:section-title>
  <ce:para><ce:italic>In a right-angled triangle the square of
the hypotenuse is equal to the sum of the squares of the other
two sides.</ce:italic></ce:para>

```

`</ce:enunciation>`

*Presentation*

**Theorem 1.25** (Pythagoras' Theorem). *In a right-angled triangle the square of the hypotenuse is equal to the sum of the squares of the other two sides.*

## Version history

Prior to DTD 5.0, this element was called `enun`.

## Copy edit considerations

It is well-known that certain enunciations, such as theorems and lemmas, are usually rendered in italics while others, such as definitions, are not. The `ce:enunciation` element has no provision to indicate a type; italics must be indicated explicitly.

## Rendering notes

The `ce:label` element is rendered in the style of the journal — i.e, if the style is to present the `ce:label` in bold, this should not be explicitly marked up. The `ce:section-title`, whose standard presentation is italics, generates parentheses. Closing full stops are generated.

## Light reading

`ce:enunciation` may not be used in CONTENTS-ENTRY-ONLY, HEAD-ONLY or HEAD-AND-TAIL files.

## ce:exam-answers

### Declaration

#### Model (CEPs 1.1.0–1.1.6)

```
<!ELEMENT ce:exam-answers ( ce:section-title?, %parsec; )>
<!ATTLIST ce:exam-answers
  id ID #IMPLIED
  role CDATA #IMPLIED
  view %view; 'all'>
```

### Description

`ce:exam-answers` is used to capture the answers for a Continuous Medical Examination or similar.

### Usage

`ce:exam-answers` has a similar content model to `ce:section`. Therefore it can accommodate a wide range of forms of examination answers. However, it can neither have a `ce:label` nor subsections.

#### XML

```
<ce:exam-answers>
  <ce:section-title>Answers ...</ce:section-title>
  <ce:para>Identification...</ce:para>
  <ce:para>
    <ce:display>
      <ce:table id="cme-ans" frame="none">
        <ce:caption>Questions 1-30, ...</ce:caption>
        <tgroup cols="4" colsep="0" rowsep="0" align="char">
          <tbody>
            <colspec colnum="1" colwidth="5pc" char="." charoff="50">
            <colspec colnum="2" colwidth="5pc" char="." charoff="50">
            <colspec colnum="3" colwidth="5pc" char="." charoff="50">
            <colspec colnum="4" colwidth="5pc" char="." charoff="50">
            <row>
              <entry>1. c</entry>
              <entry>9. b</entry>
              <entry>17. a</entry>
              <entry>25. a</entry>
            </row>
            ...
          </tbody></tgroup>
        </ce:table>
      </ce:display>
    </ce:para>
  </ce:exam-answers>
```

### Version history

This element is new in DTD 5. The `view` attribute was added in CEP 1.1.0.



## ce:exam-questions

### Declaration

#### Model (CEPs 1.1.0–1.1.6)

```
<!ELEMENT ce:exam-questions ( ce:section-title?, %parsec; )>
<!ATTLIST ce:exam-questions
    id ID #IMPLIED
    role CDATA #IMPLIED
    view %view; 'all'>
```

### Description

[ce:exam-questions](#) is used to capture the questions for a Continuous Medical Examination or similar.

### Usage

[ce:exam-questions](#) has a similar content model to [ce:section](#). Therefore it can accommodate a wide range of forms of examination questions. However, it can neither have a [ce:label](#) nor subsections.

An example of examination questions is shown in Figs. 8 and 9.

### Version history

This element is new in DTD 5. The [view](#) attribute was added in CEP 1.1.0.

---

**FERTILITY AND STERILITY®**  
**CONTINUING MEDICAL EDUCATION QUESTIONS**

To obtain the 15 Category I CME credits, the **entire** examination of lessons from Volume 81 of *Fertility and Sterility*® must be taken. The answer sheet will be available in the June 2004 issue and will be graded. A 70% passing score must be achieved and documentation will be mailed with the corrected examination to the participant.

**SART and ASRM. 81:1207–20 (Lesson 16)**

*Objective:* To summarize the procedures and outcomes of assisted reproductive technologies (ART) initiated in the United States during 2000

1. For all IVF cycles in the Society for Assisted Reproductive Technology (SART) 2000 registry, what was the approximate percentage of singleton deliveries?
  - a) 60%
  - b) 65%
  - c) 70%
  - d) 75%
  - e) 80%
2. Using deliveries per transfer from the SART 2000 data, what is the approximate reduced likelihood for success in a woman aged >40 compared with a woman <35 years?
  - a) 40%
  - b) 50%
  - c) 60%
  - d) 70%
  - e) 80%

**Virro et al. 81:1289–95 (Lesson 17)**

*Objective:* To determine the relationship between sperm chromatin structure assay parameters (DNA fragmentation index, DFI; high DNA stainability, HDS) and IVF and IVF/intracytoplasmic sperm injection outcomes

1. When fertilization is on day 1 and blastocyst development is on day 5, on which day does embryo genome expression begin?
  - a) day 1
  - b) day 2
  - c) day 3
  - d) day 4
  - e) day 5

⋮

---

Figure 8: An example of Continuing Medical Education Questions. Its XML coding can be found in Fig. 9.

---

```

<ce:exam-questions>
  <ce:section-title><ce:italic>FERTILITY AND STERILITY</ce:italic>&reg;
  CONTINUING MEDICAL EDUCATION QUESTIONS</ce:section-title>
  <ce:para>To obtain the 15 Category I CME credits, the
  <ce:bold>entire</ce:bold> examination of lessons from Volume 81 of
  <ce:italic>Fertility and Sterility</ce:italic>&reg; must be
  taken. The answer sheet will be available in the June 2004 issue
  and will be graded. A 70% passing score must be achieved and
  documentation will be mailed with the corrected examination to the
  participant.</ce:para>
  <ce:section>
    <ce:section-title>SART and ASRM. 81:1207&ndash;20 (Lesson 16)</ce:section-title>
    <ce:para><ce:italic>Objective:</ce:italic> To summarize the
    procedures and outcomes of assisted reproductive technologies
    (ART) initiated in the United States during 2000</ce:para>
    <ce:list>
      <ce:list-item>
        <ce:label>1.</ce:label>
        <ce:para>For all IVF cycles in the Society for Assisted
        Reproductive Technology (SART) 2000 registry, what was the
        approximate percentage of singleton deliveries?</ce:para>
        <ce:list>
          <ce:list-item><ce:label>a</ce:label><ce:para>60%</ce:para></ce:list-item>
          <ce:list-item><ce:label>b</ce:label><ce:para>65%</ce:para></ce:list-item>
          <ce:list-item><ce:label>c</ce:label><ce:para>70%</ce:para></ce:list-item>
          <ce:list-item><ce:label>d</ce:label><ce:para>75%</ce:para></ce:list-item>
          <ce:list-item><ce:label>e</ce:label><ce:para>80%</ce:para></ce:list-item>
        </ce:list>
      </ce:list-item>
      <ce:list-item>
        <ce:label>2.</ce:label>
        <ce:para>Using deliveries per transfer from the SART 2000
        data, what is the approximate reduced likelihood for success
        in a woman aged >40 compared with a woman <35
        years?</ce:para>
        <ce:list>
          <ce:list-item><ce:label>a</ce:label><ce:para>40%</ce:para></ce:list-item>
          <ce:list-item><ce:label>b</ce:label><ce:para>50%</ce:para></ce:list-item>
          <ce:list-item><ce:label>c</ce:label><ce:para>60%</ce:para></ce:list-item>
          <ce:list-item><ce:label>d</ce:label><ce:para>70%</ce:para></ce:list-item>
          <ce:list-item><ce:label>e</ce:label><ce:para>80%</ce:para></ce:list-item>
        </ce:list>
      </ce:list-item>
    </ce:list>
  </ce:section>
  <ce:section>
    <ce:section-title>Virro et al. 81:1289&ndash;95 (Lesson 17)</ce:section-title>
    <ce:para><ce:italic>Objective:</ce:italic> To determine the
    relationship between sperm chromatin structure assay parameters
    (DNA fragmentation index, DFI; high DNA stainability, HDS) and
    IVF and IVF/intracytoplasmic sperm injection outcomes</ce:para>
    <ce:list>
      <ce:list-item>
        <ce:label>1.</ce:label>
        <ce:para>When fertilization is on day 1 and blastocyst
        development is on day 5, on which day does embryo genome
        expression begin?</ce:para>
        <ce:list>
          <ce:list-item><ce:label>a</ce:label><ce:para>day 1</ce:para></ce:list-item>
          <ce:list-item><ce:label>b</ce:label><ce:para>day 2</ce:para></ce:list-item>
          <ce:list-item><ce:label>c</ce:label><ce:para>day 3</ce:para></ce:list-item>
          <ce:list-item><ce:label>d</ce:label><ce:para>day 4</ce:para></ce:list-item>
          <ce:list-item><ce:label>e</ce:label><ce:para>day 5</ce:para></ce:list-item>
        </ce:list>
      </ce:list-item>
      .
      .
      .
    </ce:list>
  </ce:section>
  ...
</ce:exam-questions>

```

---

Figure 9: XML of the examination questions shown in Fig. 8.

## ce:exam-reference

### Declaration

#### Model (CEPs 1.1.0–1.1.6)

```
<!ELEMENT ce:exam-reference ( ce:inter-ref )>
<!ATTLIST ce:exam-reference
          view          %view;          'all'>
```

### Description

The element `ce:exam-reference` is used to create a link to an associated examination that is in a separate article.

### Usage

Sometimes the examination associated with an article is not published as part of the article but as a separate article. The element `ce:exam-reference` can be used to create a link in the article to the examination.

Only the values `pii` and `doi` for the scheme in `xlink:href` are allowed.

*XML*

```
<ce:exam-reference>
  <ce:inter-ref id="interref7"
    xlink:href="pii:S0004-3702(02)00193-5">See the examination
    questions in the following article.</ce:inter-ref>
</ce:exam-reference>
```

### Version history

This element is new in DTD 5. The `view` attribute was added in CEP 1.1.0.

### Rendering notes

The text of `ce:exam-reference`, i.e., the text of the contained `ce:inter-ref` element, is rendered as a separate paragraph.

## ce:figure

### Declaration

#### Model (CEPs 1.1.0–1.1.1)

```
<!ELEMENT ce:figure ( ce:label?, ce:caption?, ce:copyright?,
( ce:link | ce:figure )+ )>
<!ATTLIST ce:figure
id ID #IMPLIED>
```

#### Model (CEP 1.1.2)

```
<!ELEMENT ce:figure ( ce:label?, ce:caption*, ( %copy-
right; )?, ( ce:link | ce:figure )+ )>
<!ATTLIST ce:figure
id ID #IMPLIED>
```

#### Model (CEPs 1.1.3–1.1.5)

```
<!ELEMENT ce:figure ( ce:label?, ce:caption*, ce:source?,
( %copyright; )?, ( ce:link |
ce:figure )+ )>
<!ATTLIST ce:figure
id ID #IMPLIED>
```

#### Model (CEP 1.1.6)

```
<!ELEMENT ce:figure ( ce:label?, ce:caption*, ce:source?,
( %copyright; )?, ( ce:link |
ce:figure )+ )>
<!ATTLIST ce:figure
id ID #IMPLIED
role CDATA #IMPLIED>
```

### Description

The element `ce:figure` is used to insert a figure in the document.

### Usage

Most articles contain artwork in one form or another, and the element `ce:figure` is used to insert the figure. The attribute `id` is used when referring to the figure.

#### XML

```
<ce:cross-ref refid="fig4">Fig. 4</ce:cross-ref>
<ce:cross-ref refid="fig4">Fig. 4(a)</ce:cross-ref>
```

#### Explanation

It is common that the text refers to parts of a figure while in fact the whole figure is cross-referenced. Indeed, in most cases the subfigure will be an integral part of the external artwork file.

Three kinds of figure are distinguished: floating and displayed figures, and figures in graphical abstracts. Floating figures are embedded in a `ce:floats` element, displayed figures are embedded in a `ce:display` element, and a figure in a graphical abstract is the (optional) subelement of `ce:abstract` behind `ce:abstract-sec`. The latter play a special role in a graphical abstract (`ce:abstract`): these are floating, and are not referred to. Their placement is governed by the style of the graphical abstract. There can be only one such figure

per abstract. Otherwise, no floating figures may occur in an abstract. (Cross-references to figures are, however, allowed, albeit highly discouraged.)

Floating figures are figures which appear near a point in the text where they are mentioned, mostly at the top or the bottom of the page, spanning one or more columns if needed. Floating figures must be referred to from within the document. To indicate where a floating figure should appear, the element `ce:float-anchor` is used, referring to a `ce:figure` within `ce:floats`. Hence, a floating figure has at least one `ce:cross-ref` or `ce:cross-refs` pointing to it, and exactly one `ce:float-anchor`.

*XML*

```
<ce:cross-ref refid="fig4">Fig. 4</ce:cross-ref> ☺
<ce:float-anchor refid="fig4"/>
```

*XML*

```
<ce:cross-refs refid="fig6 fig7">Figs. 6 and 7</ce:cross-ref> ☺
<ce:float-anchor refid="fig6"/><ce:float-anchor refid="fig7"/>
```

A displayed figure, obtained by embedding the figure in a `ce:display` element, is a figure which is displayed on a line of its own, separated from the surrounding text by white space, on the spot where it appears in the file.

Figures can be nested one level deep, i.e., a figure within a figure cannot contain yet another figure.

The subelement `ce:label` contains the name of the figure, e.g. “Fig. 2”, “Diagram B”, “Scheme 6” or “Plate III”. For floating figures it is mandatory.

The optional subelement `ce:caption` contains descriptive text of the figure in the form of one or more simple paragraphs, `ce:simple-para`. As from CEP 1.1.2, multiple captions for different languages and/or roles are supported. Different captions must have a different role or language.

The optional subelement `ce:source` is used to describe the source of the figure. The optional subelement `ce:copyright` is used if the copyright owner of the figure is different from that of the article.

### Figures without subfigures

In this subsection it is assumed that the `ce:figure` does not contain any `ce:figure` subelements.

One or more `ce:link` elements provide the link with the external artwork file(s). The artwork files are to be displayed in the order of the `ce:link` elements.

*XML*

```
<!ENTITY loc2a SYSTEM "gr2ab" NDATA IMAGE>
<!ENTITY loc2c SYSTEM "gr2c" NDATA IMAGE>
...
<ce:figure id="fig2">
  <ce:label>Fig. 2</ce:label>
  <ce:caption>
    <ce:simple-para>Caption, caption, caption ...</ce:simple-para>
  </ce:caption>
  <ce:link locator="loc2a"/>
  <ce:link locator="loc2c"/>
</ce:figure>
</ce:float>
```

*Presentation*

Fig. 2. Caption, caption, caption ...

**Figures with nested figures**

Instead of just `ce:links`, the top-level figure may contain any combination of `ce:link` and `ce:figure`. Nested `ce:figures` are used if the subfigures need their own captions or copyright statement. A nested `ce:figure` may only contain `ce:links`, no `ce:figures`.

The qualification “displayed” or “floating” is irrelevant for a subfigure. The subfigures are displayed within the main figure in the order which they appear.

Nested figures may have an `id` and may be the target of a `ce:cross-ref`. However, the effect is undefined: “clicking” on the cross-reference may lead to the whole figure or the nested figure alone. It is recommended only to cross-reference the top-level figure.

*XML*

```
<!ENTITY loc2a SYSTEM "gr2ab" NDATA IMAGE>
<!ENTITY loc2c SYSTEM "gr2c" NDATA IMAGE>
...
<ce:figure id="fig2">
  <ce:label>Fig. 2</ce:label>
  <ce:caption>
    <ce:simple-para>(a) Caption. (b) Caption.
      (c) Caption ...</ce:simple-para>
  </ce:caption>
  <ce:link locator="loc2a"/>
  <ce:figure>
    <ce:copyright type="other" yr="2000">Copyright</ce:copyright>
    <ce:link locator="loc2c"/>
  </ce:figure>
</ce:figure>
```

*Presentation*

Fig. 2. (a) Caption. (b) Caption. (c) Caption ...

*XML*

```
<!ENTITY gr3a SYSTEM "gr3a" NDATA IMAGE>
<!ENTITY gr3b SYSTEM "gr3b" NDATA IMAGE>
...
<ce:figure id="fig3">
  <ce:label>Fig. 3</ce:label>
  <ce:caption>
    <ce:simple-para>Caption, caption, caption ...</ce:simple-para>
  </ce:caption>
  <ce:figure>
    <ce:caption>
      <ce:simple-para>(a) Sub I.</ce:simple-para>
    </ce:caption>
  </ce:figure>
</ce:figure>
```

```

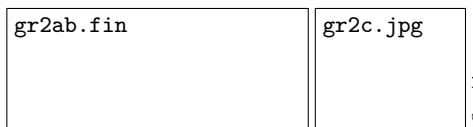
    <ce:link locator="gr3a"/>
  </ce:figure>
  <ce:figure>
    <ce:caption>
      <ce:simple-para>(b) Sub II.</ce:simple-para>
    </ce:caption>
    <ce:link locator="gr3b"/>
  </ce:figure>
</ce:figure>

```

*Presentation*

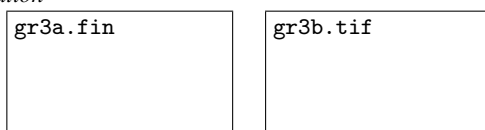

(a) Sub I.

(b) Sub II.

Fig. 3. Caption, caption, caption ...

### External entities

In practice, the external entities used in the `ce:link` element within a figure will be of notation data type `IMAGE`. Usage of the other notation types is presently undefined.

### Version history

Prior to DTD 5.0, this element was called `fig`. As from CEP 1.1.2, multiple captions are supported. Parameter entity `%copyright`; was introduced as well. Subelement `ce:source` was introduced in CEP 1.1.3. The `role` attribute was added in CEP 1.1.6.

### Copy edit considerations

In some articles, figures called, say, “Fig. 5(a)” and “Fig. 5(b)” exist, which are to be treated as floating or displayed objects in their own right. These figures are called *improper subfigures*. In such cases, it is inappropriate to use the nested `ce:figure` construction; these figures are independent top-level `ce:figures`.

### Light reading

No floating `ce:figure` may be used in `CONTENTS-ENTRY-ONLY`, `HEAD-ONLY` or `HEAD-AND-TAIL` files.

### See also

[ce:abstract](#), [ce:display](#), [ce:float-anchor](#), [ce:floats](#), [ce:inline-figure](#)



## ce:first-page

### Declaration

#### Model (CEPs 1.1.0–1.1.6)

```
<!ELEMENT ce:first-page ( %richstring.data; )*>
```

### Description

The first page of an item called by a hub file is captured using [ce:first-page](#).

### Usage

See [ce:pages](#).

### Version history

This element was added in CEP 1.1.0.

### See also

[ce:include-item](#), [ce:last-page](#)

## ce:float-anchor

### Declaration

#### Model (CEPs 1.1.0–1.1.6)

```
<!ELEMENT ce:float-anchor EMPTY>
<!ATTLIST ce:float-anchor
          refid IDREF #REQUIRED>
```

### Description

The element [ce:float-anchor](#) is a marker to indicate that a floating figure, table, textbox or e-component must appear in the vicinity.

### Usage

To indicate that a figure, table, textbox or e-component is “floating”, it is embedded within [ce:floats](#), collected at the beginning of the document.

The anchor, in the form of the empty [ce:float-anchor](#) element with a [refid](#) attribute pointing to the figure, table, textbox or e-component within [ce:floats](#), tells the rendering application that the float should be placed at a suitable place near the anchor. This anchor is often, but not always, placed after the first cross-reference to that object. There must be exactly one anchor for each floating object.

The [ce:float-anchor](#) itself generates no presentation, it marks the place near which the floating object must appear. Its [refid](#) attribute may not point to any object outside [ce:floats](#).

### See also

[ce:display](#), [ce:e-component](#), [ce:figure](#), [ce:floats](#), [ce:table](#)

## ce:floats

### Declaration

#### Model (CEPs 1.1.0–1.1.6)

```
<!ELEMENT ce:floats          ( ce:figure*, ce:table*, ce:textbox*,  
                             ce:e-component* )>
```

### Description

The element `ce:floats` is a container element for floating figures, tables, textboxes and e-components.

### Usage

To indicate that a figure, table, textbox or e-component is “floating”, it should be embedded in a `ce:floats` element, a container for all floats located at the beginning of the document, as a child of the top element.

The approximate position of the floating object is indicated by a `ce:float-anchor` element. This anchor is often, but not always, placed near the first cross-reference to that object.

### Version history

Prior to DTD 5.0, floats were placed within the in-line text.

### See also

[ce:display](#), [ce:e-component](#), [ce:figure](#), [ce:float-anchor](#), [ce:table](#)

## ce:footnote

### Declaration

#### Model (CEPs 1.1.0–1.1.5)

```
<!ELEMENT ce:footnote ( ce:label, ce:note-para+ )>
<!ATTLIST ce:footnote
  id ID #REQUIRED>
```

#### Model (CEP 1.1.6)

```
<!ELEMENT ce:footnote ( ce:label, ce:note-para+ )>
<!ATTLIST ce:footnote
  id ID #REQUIRED
  role CDATA #IMPLIED>
```

### Description

Footnotes are captured using `ce:footnote`.

### Usage

The element `ce:footnote` is used for footnotes. Footnotes are objects, which in print appear at the bottom of the page. The `ce:footnote` element contains the footnote text and additionally it is an “anchor” nearest to which the footnote should appear. The actual reference in the text is made by a `ce:cross-ref`.

Each footnote must be referred to. It has an attribute `id` so that it can be referenced. The mandatory subelement `ce:label` contains the number of the footnote. The footnote text itself consists of one or more note paragraphs, `ce:note-para`.

*XML*

```
<ce:cross-ref refid="fn1"><ce:sup>1</ce:sup></ce:cross-ref>
<ce:footnote id="fn1">
  <ce:label>1</ce:label>
  <ce:note-para>In XML files used for online rendering, it is
    possible ... </ce:note-para>
</ce:footnote>
```

### Version history

The `role` attribute was added in CEP 1.1.6.

### See also

[ce:article-footnote](#), [ce:table-footnote](#), [ce:cross-refs](#)

## ce:formula

### Declaration

#### Model (CEPs 1.1.0–1.1.6)

```
<!ELEMENT ce:formula          ( ce:label?, ( mml:math | ce:chem |
                                ce:link | ce:formula+ ) )>
<!ATTLIST ce:formula
          id          ID          #IMPLIED>
```

### Description

A displayed formula is captured using `ce:formula`.

### Usage

The element `ce:formula` is one of the possible subelements of `ce:display`. It contains a mathematical formula `mml:math`, a chemical formula `ce:chem`, a `ce:link` to the image of a formula, or nested `ce:formula` elements. The number of the formula is captured in the optional `ce:label` element.

A `mml:math` element in a `ce:formula` should not have the value `block` for the `display` attribute, but rather the default value `inline`. This is so because it is inline with respect to the containing `ce:formula` and to the formula number that the element `ce:label` generates.

#### XML

```
<ce:formula id="ch2">
  <ce:label>(2)</ce:label>
  <ce:chem>TLC (CH<ce:inf>2</ce:inf>C<ce:inf>12</ce:inf>/MeOH):
    <ce:it>R</ce:it><ce:inf>f</ce:inf>=0.45; IR:
    3423 cm<ce:sup>-1</ce:sup> (NH).</ce:chem>
</ce:formula>
```

#### Presentation

TLC (CH<sub>2</sub>C<sub>12</sub>/MeOH):  $R_f = 0.45$ ; IR: 3423 cm<sup>-1</sup> (NH). (2)

#### XML

```
<ce:formula><ce:label>(7a)</ce:label>
<mml:math altimg="si56.gif">
  <mml:mi>&alpha;</mml:mi>
  <mml:mo>=</mml:mo>
  <mml:mo>&int;</mml:mo>
  <mml:mfrac>
    <mml:mrow>
      <mml:msup>
        <mml:mi mathvariant="normal">d</mml:mi>
        <mml:mn>3</mml:mn>
      </mml:msup>
      <mml:mi>k</mml:mi>
    </mml:mrow>
    <mml:msup>
      <mml:mrow>
        <mml:mo></mml:mo>
```

```

      <mml:mn>2</mml:mn>
      <mml:mi>&pi;</mml:mi>
      <mml:mo></mml:mo>
    </mml:mrow>
    <mml:mn>3</mml:mn>
  </mml:msup>
</mml:mfrac>
<mml:mrow>
  <mml:mo>&langle;</mml:mo>
  <mml:mi mathvariant="bold">k</mml:mi>
  <mml:mo>|</mml:mo>
  <mml:mi mathvariant="bold">k</mml:mi>
  <mml:mo>+</mml:mo>
  <mml:mi mathvariant="bold">q</mml:mi>
  <mml:mo>&rangle;</mml:mo>
</mml:mrow>
</mml:math>
</ce:formula>

```

Presentation

$$\alpha = \int \frac{d^3k}{(2\pi)^3} \langle \mathbf{k} | \mathbf{k} + \mathbf{q} \rangle \quad (7a)$$

### Numbers and nesting depth

A displayed formula (`ce:formula` element) may contain other displayed formulae, in which case the main (outer) `ce:formula` may only consist of an optional `ce:label` element and one or more nested `ce:formulas`. Displayed formulae contained in a displayed formula may *not* themselves contain displayed formulae.

Like all referenceable elements, a displayed formula must have a `ce:label` element and a value for the `id` attribute if it is referred to. This holds both for top-level and for lower-level `ce:formula` elements.

The rule is more complicated for a complicated displayed formula, i.e. a displayed formula that contains nested subformulae. If a complicated displayed formula is referred to, it need not have a `ce:label` element, provided all of its subformulae have a `ce:label` element.

This is summarized in the following example:

XML

```

<ce:formula id="eq04"><ce:label>(4)</ce:label> ..... </ce:formula>
<ce:formula id="eq05">
  <ce:formula><ce:label>(5a)</ce:label> ..... </ce:formula>
  <ce:formula><ce:label>(5b)</ce:label> ..... </ce:formula>
</ce:formula>

```

```

Eqs. <ce:cross-refs refid="eq04 eq05">(4) and (5)</ce:cross-refs>

```

The requirements for nested displayed formulae are described by three rules. The first two are:

1. The `ce:label` element may occur at the nested level.
2. `ce:label` elements may not occur at both the main level and the nested level.

These rules imply the following error table for nested equations. Here a 0 or 1 means that an `id` or a `ce:label` is absent or present.

Table 6: Error table for nested equations

Case	Main level		Nested level		Error status
	id	no	id's	no's	
1	0	0	0	0	OK
2	0	0	0	1	OK
3	0	0	1	0	Error: Referenceable object should have a <code>ce:label</code> element
4	0	0	1	1	OK
5	0	1	0	0	OK
6	0	1	0	1	Error: Formula with <code>ce:label</code> element in formula with <code>ce:label</code> element
7	0	1	1	0	Error: Referenceable object should have a <code>ce:label</code> element
8	0	1	1	1	Error: Formula with <code>ce:label</code> element in formula with <code>ce:label</code> element
9	1	0	0	0	Error: Referenceable object should have a <code>ce:label</code> element
10	1	0	0	1	OK
11	1	0	1	0	Error: Referenceable object should have a <code>ce:label</code> element
12	1	0	1	1	OK
13	1	1	0	0	OK
14	1	1	0	1	Error: Formula with <code>ce:label</code> element in formula with <code>ce:label</code> element
15	1	1	1	0	Error: Referenceable object should have a <code>ce:label</code> element
16	1	1	1	1	Error: Formula with <code>ce:label</code> element in formula with <code>ce:label</code> element

Additionally there is a rule that if the `id` attribute appears at the main level, it is not possible to mix unnumbered and numbered subequations. For example, in the example above, it is not allowed to leave out one of the `ce:label` elements (5a) or (5b). To be precise:

3. If there is an `id` attribute at the main level and a `ce:label` element at the nested level, then all nested formulae must have a `ce:label` element.

## Version history

Prior to DTD 5.0, displayed formulae were directly captured in the element `f d`, without top `mml:math` or `ce:chem` element.

## Rendering notes

A formula element is rendered in the block that is generated by its parent `ce:display` element. If it has a label, its space is split into two areas. In the formula area, which is the larger (usually left-hand) area, the contained formula is rendered as an inline formula. In the label area, which is the other area, the formula label is rendered.

## ce:further-reading

### Declaration

#### Model (CEPs 1.1.0–1.1.5)

```
<!ELEMENT ce:further-reading ( ce:section-title, ce:further-reading-sec+ )>
<!ATTLIST ce:further-reading
  id ID #IMPLIED
  role CDATA #IMPLIED
  view %view; 'all'>
```

#### Model (CEP 1.1.6)

```
<!ELEMENT ce:further-reading ( ce:section-title?, ce:further-reading-sec+ )>
<!ATTLIST ce:further-reading
  id ID #IMPLIED
  role CDATA #IMPLIED
  view %view; 'all'>
```

### Description

The element `ce:further-reading` contains a list of bibliographic references which are meant as further reading material.

### Usage

The element `ce:further-reading` is an optional part of the tail. It contains bibliographic references which are meant for further reading.

A further-reading list has a `ce:section-title`, which contains the name of the list, e.g. “Further reading”. The list itself contains one or more sections, `ce:further-reading-sec`. Each `ce:further-reading-sec` can also have a `ce:section-title`, which is a second-order heading. All further-reading sections except the first must have a `ce:section-title`, for the first this is optional.

The further-reading section contains any combination of bibliographic references, `ce:bib-reference`, and paragraphs, `ce:para`. Unlike the `ce:bib-references` within an ordinary bibliography (`ce:bibliography`), each `ce:bib-reference` may or may not be referred to by means of `ce:cross-ref` or `ce:cross-refs`. In further-reading lists, the references are often interspersed with text; this is why paragraphs can be inserted between the entries. This is different from the `sb:comment` and `ce:note` which exist within `ce:bib-reference`, since those elements belong uniquely to the specific reference.

### Version history

The `view` attribute was added in CEP 1.1.0. Subelement `ce:further-reading` was made optional in CEP 1.1.6.

### Light reading

`ce:further-reading` is part of HEAD-AND-TAIL material.



### **See also**

Structured references are explained in more detail in the section [Bibliographic references](#) (p. 394).

## ce:further-reading-sec

### Declaration

#### Model (CEPs 1.1.0–1.1.5)

```
<!ELEMENT ce:further-reading-sec( ce:section-title?, ( ce:para |
                                ce:bib-reference )+ )>
<!ATTLIST ce:further-reading-sec
          id          ID          #IMPLIED
          role        CDATA      #IMPLIED>
```

#### Model (CEP 1.1.6)

```
<!ELEMENT ce:further-reading-sec( ce:section-title?, ( ce:para |
                                ce:bib-reference )+ )>
<!ATTLIST ce:further-reading-sec
          id          ID          #IMPLIED
          role        CDATA      #IMPLIED
          view        %view;     'all'>
```

### Description

The element `ce:further-reading-sec` is a section within the further-reading list.

### Usage

See `ce:further-reading`.

### Version history

The `view` attribute was added in CEP 1.1.6.

## ce:given-name

### Declaration

#### Model (CEPs 1.1.0–1.1.6)

```
<!ELEMENT ce:given-name ( %richstring.data; )*>
```

### Description

The given name of an author or editor (also known as forename, Christian name) is tagged using [ce:given-name](#).

### Usage

For non-Western persons, the [ce:given-name](#) is unreliable, and therefore the [ce:given-name](#) and [ce:surname](#) should always be used together.

#### XML

```
<ce:author>
  <ce:given-name>Franklin D.</ce:given-name>
  <ce:surname>Roosevelt</ce:surname>
</ce:author>
```

### See also

[ce:author](#)

## ce:glossary

### Declaration

#### Model (CEPs 1.1.0–1.1.5)

```
<!ELEMENT ce:glossary          ( ce:section-title, ce:intro?,
                                ce:glossary-sec+ )>
<!ATTLIST ce:glossary
  id          ID          #IMPLIED
  role        CDATA      #IMPLIED
  view        %view;     'all'>
```

#### Model (CEP 1.1.6)

```
<!ELEMENT ce:glossary          ( ce:section-title?, ce:intro?,
                                ce:glossary-sec+ )>
<!ATTLIST ce:glossary
  id          ID          #IMPLIED
  role        CDATA      #IMPLIED
  view        %view;     'all'>
```

### Description

A glossary is a list of terms or symbols, sometimes with a definition, and sometimes with a reference to the occurrence in the text, appearing in the backmatter of an article.

### Usage

A glossary consists of one or more `ce:glossary-secs`, each containing a subsection within the glossary.

The section title, `ce:section-title`, contains the title of the glossary, e.g. “Glossary”.

The subelement `ce:intro`, consisting of one or more paragraphs, is an introductory section at the beginning of the glossary.

Often, a glossary is not subdivided into subsections, in which case it contains just one `ce:glossary-sec`. If there are subsections, each subsequent `ce:glossary-sec` must have a `ce:section-title`, whereas this is optional for the first.

A glossary (section) contains one or more entries, described under `ce:glossary-entry`.

### Version history

The `view` attribute was added in CEP 1.1.0. The optional `ce:intro` was introduced in CEP 1.1.1. Subelement `ce:section-title` was made optional in CEP 1.1.6.

## ce:glossary-def

### Declaration

#### Model (CEPs 1.1.0–1.1.6)

```
<!ELEMENT ce:glossary-def ( %text.data; )*>
```

### Description

Within a glossary entry, [ce:glossary-def](#) is used to capture the definition of a glossary item.

### Usage

See [ce:glossary-entry](#).

## ce:glossary-entry

### Declaration

#### Model (CEPs 1.1.0–1.1.3)

```
<!ELEMENT ce:glossary-entry ( ce:glossary-heading, ce:glossary-def*,
( %cross-ref; )*, ce:glossary-
entry* )>
<!ATTLIST ce:glossary-entry
id ID #IMPLIED
role CDATA #IMPLIED>
```

#### Model (CEPs 1.1.4–1.1.6)

```
<!ELEMENT ce:glossary-entry ( ce:indexed-name?, ce:glossary-heading,
ce:glossary-def*, ( %glossary-
entry-refs; )?, ( ce:see-also |
ce:glossary-entry | ce:reader-
see )* )>
<!ATTLIST ce:glossary-entry
id ID #IMPLIED
role CDATA #IMPLIED>
```

### Description

The glossary or a glossary section consists of one or more glossary entries. The element [ce:glossary-entry](#) is provided in order to capture such an entry.

### Usage

A [ce:glossary-entry](#) consists of an optional [ce:indexed-name](#) with the term under which the entry should appear in a glossary, a mandatory [ce:glossary-heading](#), followed by zero or more [ce:glossary-defs](#), an optional list of [ce:cross-ref](#) and [ce:intra-ref](#) (provided the DTD supports this element), and zero or more nested glossary entries.

A glossary entry has an optional `id` attribute, which can be used to make cross-references from expressions in the text to the terms in the glossary.

#### Glossary heading and definition

A glossary heading, [ce:glossary-heading](#) contains the term.

A glossary entry may or may not have accompanying definitions. An example where it has none is when it contains nested entries. The following has one or two definitions per entry.

*XML*

```
<ce:glossary-entry>
  <ce:glossary-heading><ce:italic>a</ce:italic></ce:glossary-heading>
  <ce:glossary-def>acceleration
    (m/s<ce:sup>2</ce:sup></ce:glossary-def>
</ce:glossary-entry>
<ce:glossary-entry>
  <ce:glossary-heading><ce:italic>e</ce:italic></ce:glossary-heading>
  <ce:glossary-def>charge of an electron
```

```

(1.6022&times;10<ce:sup>&minus;19</ce:sup> C)
<ce:hsp sp="0.25"/>C</ce:glossary-def>
<ce:glossary-def>base of natural logarithm
(2.718281828)</ce:glossary-def>
</ce:glossary-entry>
<ce:glossary-entry>
  <ce:glossary-heading><ce:italic>F</ce:italic></ce:glossary-heading>
  <ce:glossary-def>force (N)</ce:glossary-def>
</ce:glossary-entry>

```

*Presentation*

*a*, acceleration (m/s<sup>2</sup>)  
*e*, charge of an electron (1.6022 · 10<sup>-19</sup> C),  
 base of natural logarithm (2.718281828)  
*F*, force (N)

**Cross-references**

If there are page numbers or section numbers referring to the place in the text where the term is used, they can be tagged using the `ce:cross-ref` and `ce:intra-ref` subelements, see the first example above. Depending on the value of `%cross-ref`; the `ce:intra-ref` may or may not be present; this depends on which DTD the glossary is structured with.

Of course, reference to *page* numbers is not appropriate in electronic media. Therefore, the `ce:cross-ref` and `ce:intra-ref` may also be empty here, meaning that the rendering application must provide another way to establish a “clickable” link, e.g. by turning the whole entry into a hyperlink or by providing a button.

**Nested glossary entries**

Glossary entries can be nested. Two sublevels are allowed.

*XML*

```

<ce:glossary-entry>
  <ce:glossary-heading>
    <ce:monospace>biographyid</ce:monospace>, attribute of
    <ce:monospace>author</ce:monospace>
  </ce:glossary-heading>
  <ce:glossary-def>
    link to the author's biography
  </ce:glossary-def>
</ce:glossary-entry>
<ce:glossary-entry>
  <ce:glossary-heading>
    <ce:monospace>year</ce:monospace>
  </ce:glossary-heading>
  <ce:glossary-entry>
    <ce:glossary-heading>
      attribute of <ce:monospace>date-accepted</ce:monospace>
    </ce:glossary-heading>
    <ce:glossary-def>year of acceptance</ce:glossary-def>
  </ce:glossary-entry>
  <ce:glossary-entry>
    <ce:glossary-heading>
      attribute of <ce:monospace>copyright</ce:monospace>
    </ce:glossary-heading>
    <ce:glossary-def>copyright year</ce:glossary-def>
  </ce:glossary-entry>
</ce:glossary-entry>

```

```
</ce:glossary-entry>  
</ce:glossary-entry>
```

*Presentation*

biographyid, attribute of author, link to the author's biography  
year  
attribute of date-accepted, year of acceptance  
attribute of copyright, copyright year

**Version history**

Parameter entity [%glossary-entry-refs](#); and element [ce:indexed-name](#) were introduced in CEP 1.1.4.



## ce:glossary-heading

### Declaration

#### Model (CEPs 1.1.0–1.1.6)

```
<!ELEMENT ce:glossary-heading ( %textref.data; )*>
```

### Description

Within a glossary entry, [ce:glossary-heading](#) is used to capture the item that is defined.

### Usage

See [ce:glossary-entry](#).

## ce:glossary-sec

### Declaration

#### Model (CEPs 1.1.0–1.1.5)

```
<!ELEMENT ce:glossary-sec ( ce:section-title?, ce:intro?,
                             ce:glossary-entry+ )>
<!ATTLIST ce:glossary-sec
           id          ID          #IMPLIED
           role        CDATA      #IMPLIED>
```

#### Model (CEP 1.1.6)

```
<!ELEMENT ce:glossary-sec ( ce:section-title?, ce:intro?,
                             ce:glossary-entry+ )>
<!ATTLIST ce:glossary-sec
           id          ID          #IMPLIED
           role        CDATA      #IMPLIED
           view        %view;     'all'>
```

### Description

The element `ce:glossary-sec` is a section within the glossary.

### Usage

See `ce:glossary`.

### Version history

The `view` attribute was added in CEP 1.1.6.

## ce:glyph

### Declaration

#### Model (CEPs 1.1.0–1.1.6)

```
<!ELEMENT ce:glyph EMPTY>
<!ATTLIST ce:glyph
  name %glyph-names; #REQUIRED>
```

### Description

Symbols for which no Unicode code point exists, may be captured in a `ce:glyph` element.

### Usage

The Elsevier Grid contains a small number of symbols for which no Unicode code point exists. This concerns especially symbols for chemistry and linguistics. Such symbols can be captured using the `ce:glyph` element. It has a required `name` attribute, which contains the name of the glyph. Its value must be one of a list of names enumerated in the DTD. See the section on `glyphs` (p. 26) for an overview.

It is expected that newer versions of Unicode will incorporate some or all of the glyphs defined by `ce:glyph`. Unicode characters are always preferred over `ce:glyphs`.

*XML*

```
Bi(N0<inf>3</inf><ce:glyph name="rad"/>5H<inf>2</inf>0
```

*XML*

```
C<ce:glyph name="dbnd"/>N bond
```

### Version history

Prior to DTD 5.0, all non-ascii symbols were entered as character entities.

### Rendering notes

A glyph element is rendered with the glyph of that name that is shown in the Elsevier Grid, or with a similar glyph in a different font/style.

## ce:grant-number

### Declaration

#### Model (CEPs 1.1.5, 1.1.6)

```
<!ELEMENT ce:grant-number ( %text.data; )*>
<!ATTLIST ce:grant-number
    refid IDREF #REQUIRED>
```

### Description

The element [ce:grant-number](#) contains the identification of a grant under which the document was written.

### Usage

The element [ce:grant-number](#) is linked to a [ce:grant-sponsor](#) through its mandatory [refid](#) attribute.

*XML*

```
<ce:grant-number refid="grant4">EF-2008.001</ce:grant-number>
```

For more information, see [ce:grant-sponsor](#).

### Version history

[ce:grant-number](#) was added in CEP 1.1.5.

### See also

[ce:grant-sponsor](#)

## ce:grant-sponsor

### Declaration

#### Model (CEPs 1.1.5, 1.1.6)

```
<!ELEMENT ce:grant-sponsor ( %text.data; )*>
<!ATTLIST ce:grant-sponsor
  id ID #IMPLIED
  role CDATA #IMPLIED
  xlink:type ( simple ) #FIXED "simple"
  xlink:role CDATA #FIXED "http://www.elsevier.com/xml/linking-roles/grant-
  xlink:href CDATA #IMPLIED
  sponsor-id CDATA #IMPLIED>
```

### Description

The element `ce:grant-sponsor` contains the name of an organisation that supported the authors.

### Usage

Funding received by the authors of scientific works is acknowledged in the acknowledgement section, in footnotes or elsewhere in the document. The elements `ce:grant-number` and `ce:grant-sponsor`, modeled after elements in the NLM Publishing DTD, allow tagging the grant information.

The content of the element `ce:grant-sponsor` is an organisation that supported the authors. The optional attribute `xlink:href` contains a URI that belongs to the funding body or the grant scheme of the funding body. The `id` attribute is the target of one or more `ce:grant-number` elements containing the identifications of the grants that were awarded by the authors. The attribute `sponsor-id` can be used to uniquely identify the sponsor.

#### XML

```
<ce:acknowledgment> <ce:simple-para>This work was supported by the
<ce:grant-sponsor xlink:href="http://www.pharmafoundation.org/"
id="GS1">Pharmaceutical Research and Manufacturers of America
Foundation</ce:grant-sponsor>, the <ce:grant-sponsor
xlink:href="http://www.energy.gov" id="GS2">United States Department
of Energy</ce:grant-sponsor> Office of Science (BER) grant number
<ce:grant-number refid="GS2">DE-FG02-04ER63803</ce:grant-
number>, the
<ce:grant-sponsor xlink:href="http://www.nih.gov" id="GS3">National
Institutes of Health</ce:grant-sponsor>, <ce:grant-
sponsor
xlink:href="http://www.nsf.gov" id="GS4">National Science
Foundation</ce:grant-sponsor> FIBR Award <ce:grant-number
rid="GS4">EF-0425719</ce:grant-number>, the <ce:grant-sponsor
xlink:href="http://www.nhlbi.nih.gov/meetings/proteomics.htm"
id="GS5">National Heart, Lung, and Blood Proteomics
Initiative</ce:grant-
sponsor> (<ce:grant-number
refid="GS5">HHSN268200248178C</ce:grant-
number>), the Whitaker
Foundation, and Cellicon Biotechnologies, Inc.</ce:simple-para>
</ce:acknowledgment>
```

### **Version history**

[ce:grant-sponsor](#) was added in CEP 1.1.5.

### **See also**

[ce:grant-number](#)

## ce:hsp

### Declaration

#### Model (CEPs 1.1.0–1.1.6)

```
<!ELEMENT ce:hsp EMPTY>
<!ATTLIST ce:hsp
    sp NMTOKEN "1.0">
```

### Description

The element `ce:hsp` is used to create explicit horizontal space.

### Usage

The element `ce:hsp` should be used as little as possible. Should the need arise to indicate explicitly the insertion of spaces, `ce:hsp` can be used. The element has one attribute, `sp`, which denotes the width of the space measured in “em”s of the current font. The default value if `sp` is omitted is 1.0.

#### XML

```
... concludes the proof.<ce:hsp sp="1.0"/>&sq;
```

#### Presentation

```
... concludes the proof. □
```

The value of `sp` is a positive floating number. It is not possible to use `ce:hsp` for kerning or creating compound symbols.

### See also

[&nbsp;](#), [&puncsp](#);

## ce:imprint

### Declaration

#### Model (CEPs 1.1.1–1.1.6)

```
<!ELEMENT ce:imprint ( %richstring.data; )*>
```

### Description

The imprint of e.g. a book project can be captured with element `ce:imprint`.

### Usage

The element `ce:imprint` is used in the identification portions of books DTDs and identifies the imprint under which the book project is published.

*XML*

```
<ce:imprint>Academic Press</ce:imprint>  
<ce:imprint>Churchill Livingstone</ce:imprint>
```

### Version history

This element was added in CEP 1.1.1.



## ce:include-item

### Declaration

#### Model (CEPs 1.1.0, 1.1.0.1)

```
<!ELEMENT ce:include-item ( ce:pri, ce:doi?, %titles;,
                          ce:pages* )>
<!ATTLIST ce:include-item
  role          CDATA          #IMPLIED
  view         %view;         'all'>
```

#### Model (CEPs 1.1.1–1.1.6)

```
<!ELEMENT ce:include-item ( ce:pri, ce:doi?, ( %titles; )?,
                          ce:pages* )>
<!ATTLIST ce:include-item
  role          CDATA          #IMPLIED
  view         %view;         'all'>
```

### Description

The element `ce:include-item` is used to call documents (articles, chapters, appendices, etc.) into the central hub XML file for books or journal issues.

### Usage

The `ce:include-item` element is used to call lower-level files such as chapters into the central hub XML file for books or journal issues.

The subelements `ce:pri` and `ce:doi` are used to identify the called document. Its attribute `role` can be used to inform the application about the type of document to expect, e.g. a chapter, and index or a glossary. Currently only the role add-on is defined.

The `ce:include-item` element also contains a title (`ce:title`) and possibly a subtitle (`ce:subtitle`), and it may contain a sequence of titles (`ce:alt-title`) and subtitles (`ce:alt-subtitle`) in an alternative language. The page range or page ranges of the included item can be given in `ce:pages`. These elements are present to aid in identifying the referred documents, but more importantly, to enable rendering a table of contents using the hub XML file.

In journal issue files the titles are *not* used. In case a hub file does contain titles, the title elements can be used to display a different title, e.g. an abbreviated one.

XML

```
<ce:include-item>
  <ce:pri>B0-12-227085-1/00001-1</ce:pri>
  <ce:title>Core Issues in Primary Care</ce:title>
</ce:include-item>
<ce:include-item>
  <ce:pri>B0-12-227085-1/00002-3</ce:pri>
  <ce:title>Subject index</ce:title>
</ce:include-item>
```

XML

```

<ce:include-item>
  <ce:pII>S0010-2180(03)00289-X</ce:pII>
  <ce:doi>10.1016/j.combustflame.2003.11.005</ce:doi>
  <ce:pages>
    <ce:first-page>371</ce:first-page>
    <ce:last-page>376</ce:last-page>
  </ce:pages>
</ce:include-item>
<ce:include-item>
  <ce:pII>S0010-2180(03)00298-0</ce:pII>
  <ce:doi>10.1016/j.combustflame.2003.12.001</ce:doi>
  <ce:pages>
    <ce:first-page>428</ce:first-page>
  </ce:pages>
</ce:include-item>

```

*XML*

```

<issue-body>
  <issue-sec>
    <ce:include-item>
      <ce:pII>S9999-9943(97)00432-4</ce:pII>
      <ce:doi>10.1016/j.ttrh.1990.06.078</ce:doi>
      <ce:pages>
        <ce:first-page>1</ce:first-page>
        <ce:last-page>73</ce:last-page>
      </ce:pages>
    </ce:include-item>
    <ce:include-item>
      <ce:pII>S9999-9943(97)00433-6</ce:pII>
      <ce:doi>10.1016/j.ttrh.1990.06.079</ce:doi>
      <ce:pages>
        <ce:first-page>74</ce:first-page>
        <ce:last-page>155</ce:last-page>
      </ce:pages>
    </ce:include-item>
    <ce:include-item role="add-on">
      <ce:pII>S9999-9943(97)00434-8</ce:pII>
      <ce:doi>10.1016/j.ttrh.1990.06.080</ce:doi>
      <ce:pages>
        <ce:first-page>155</ce:first-page>
      </ce:pages>
    </ce:include-item>
    <ce:include-item role="add-on">
      <ce:pII>S9999-9943(97)00435-X</ce:pII>
      <ce:doi>10.1016/j.ttrh.1990.06.081</ce:doi>
      <ce:pages>
        <ce:first-page>156</ce:first-page>
      </ce:pages>
    </ce:include-item>
    ...
  </issue-sec>
</issue-body>

```

The attribute `role` allows one to categorize the included items. For instance, it makes it possible to mark “add-on” items, and handle these in different ways than ordinary items.

Applications should treat `ce:include-items` with roles unknown to them as ordinary items, i.e., unknown roles must be ignored. The role must belong to a list validated by the XML validation tools. The following values for `role` have been defined:

- `add-on` is used in the issue hub to indicate that the item is an add-on item. The main item does not use this attribute. Included items that belong to a section of abstracts, or news items, etc., do not possess this attribute.
- `index`, `glossary`, and `bibliography` are used in an MRW hub to indicate that the item is an index, glossary or bibliography, respectively.

### Version history

This element was introduced in CEP 1.1.0. In CEP 1.1.1 the titles were made optional.

## ce:index

### Declaration

#### Model (CEPs 1.1.0–1.1.5)

```
<!ELEMENT ce:index ( ce:section-title, ce:intro?, ce:index-sec+ )>
<!ATTLIST ce:index
  id ID #IMPLIED
  role CDATA #IMPLIED
  view %view; 'all'>
```

#### Model (CEP 1.1.6)

```
<!ELEMENT ce:index ( ce:section-title?, ce:intro?, ce:index-sec+ )>
<!ATTLIST ce:index
  id ID #IMPLIED
  role CDATA #IMPLIED
  view %view; 'all'>
```

### Description

An index is a list of terms (index entries) and references to places in the text that are relevant to each term.

### Usage

An index is a list of terms (index entries) and references to places in the text that are relevant to each term. The index entries are divided in sections. It is possible to nest terms.

The subelement `ce:intro`, consisting of one or more paragraphs, is an introductory section at the beginning of the index.

If there is more than one `ce:index-sec`, then each must have a `ce:section-title`, except for the first which is optional.

Different types of indexes are possible, e.g. subject index, name index, and formula index. An entry in a subject index is a concept described in the work for which the subject index is compiled; an entry in a name index is the name of a person referred to in the text of the work; an entry in a formula index is a (chemical) formula occurring in the text of the work. The type of index can be indicated by the attribute `role`.

Index sections are lists of index entries, `ce:index-entry`. Each index entry starts with text describing the index entry, the index heading (`ce:index-heading`). This can be followed by a “see” reference or a number of cross-references. These can be followed by “see also” references and nested index entries in an arbitrary order.

Cross-references within the index can occur and are of two types: “see” (`ce:see`) and “see also” (`ce:see-also`). A “see” reference points to a term that is *preferred* over the present one. A “see also” reference points to a term that is *related* to the present one.

Most index entries point to one or more places in the text that is relevant to that index entry. This is achieved through the `ce:cross-ref` or `ce:intra-ref` element. The latter

is to be used for referencing to documents that are part of a collection, for instance a major reference work.

The following example is based on a major reference work:

*XML*

```
<ce:index>
  <ce:section-title>Subject Index</ce:section-title>
  ...
  <ce:index-sec>
    <ce:index-entry id="idx33">
      <ce:index-heading>continuing professional
        education (CPE)</ce:index-heading>
    <ce:index-entry id="idx34">
      <ce:index-heading>in clinical psychology</ce:index-heading>
      <ce:intra-ref
        xlink:href="pii:B0895560666020439#p035">5</ce:intra-ref>
    <ce:index-entry id="idx35">
      <ce:index-heading>initiatives</ce:index-heading>
      <ce:intra-ref
        xlink:href="pii:B0895560666020439#p254">45</ce:intra-ref>
    </ce:index-entry>
  </ce:index-entry>
  <ce:index-entry id="idx36">
    <ce:index-heading>and cognitive style</ce:index-heading>
    <ce:intra-ref
      xlink:href="pii:B0895560666020439#p523">205</ce:intra-ref>
    <ce:index-entry id="idx37">
      <ce:index-heading>categories</ce:index-heading>
      <ce:intra-ref
        xlink:href="pii:B0895560666020439#p108">80</ce:intra-ref>
    </ce:index-entry>
  <ce:index-entry id="idx38">
    <ce:index-heading>criticisms</ce:index-heading>
    <ce:intra-ref
      xlink:href="pii:B0895560666020439#p431">200</ce:intra-ref>
    </ce:index-entry>
  <ce:index-entry id="idx39">
    <ce:index-heading>for practitioners</ce:index-heading>
    <ce:intra-ref
      xlink:href="pii:B0895560666020439#p512">150</ce:intra-ref>
    </ce:index-entry>
  </ce:index-entry>
  <ce:index-entry id="idx40">
    <ce:index-heading>credits</ce:index-heading>
  <ce:index-entry id="idx41">
    <ce:index-heading>mandatory requirements</ce:index-heading>
    <ce:intra-ref
      xlink:href="pii:B0895560666020427#p735">195</ce:intra-ref>
    </ce:index-entry>
  <ce:index-entry id="idx42">
    <ce:index-heading>and recredentialing</ce:index-heading>
    <ce:intra-ref
      xlink:href="pii:B0895560666020427#p599">185</ce:intra-ref>
    </ce:index-entry>
</ce:index>
```

```

</ce:index-entry>
<ce:index-entry id="idx43">
  <ce:index-heading>definitions</ce:index-heading>
  <ce:intra-ref
    xlink:href="pii:B0895560666020439#p771">25</ce:intra-ref>
</ce:index-entry>
<ce:see-also refid="idx97">mandatory continuing professional
  education (MCPE)</ce:see-also>
</ce:index-entry>
<ce:index-entry id="idx44">
  <ce:index-heading>continuity theory, and
  bereavement</ce:index-heading>
  <ce:intra-ref
    xlink:href="pii:B0895560666070235#p974">250</ce:intra-ref>
</ce:index-entry>
<ce:index-entry id="idx45">
  <ce:index-heading>conversion disorder</ce:index-heading>
  <ce:see refid="idx46">conversion neurosis</ce:see>
</ce:index-entry>
<ce:index-entry id="idx46">
  <ce:index-heading>conversion neurosis</ce:index-heading>
  <ce:intra-ref
    xlink:href="pii:B0895560666052541#p961">25</ce:intra-ref>
</ce:index-entry>
...
<ce:index-entry id="idx97">
  <ce:index-heading>mandatory continuing professional
  education (MCPE)</ce:index-heading>
  <ce:intra-ref
    xlink:href="pii:B0895560666052541#p683">255</ce:intra-ref>
</ce:index-entry>
</ce:index-sec>
...
</ce:index>

```

*Presentation***Subject Index**

```

...
continuing professional education (CPE)
  in clinical psychology 5
  initiatives 45
  and cognitive style 205
  categories 80
  criticisms 200
  for practitioners 150
credits
  mandatory requirements 195
  and recredentialing 185
definitions 25
  see also mandatory continuing professional education (MCPE)
continuity theory, and bereavement 250
conversion disorder
  see conversion neurosis
conversion neurosis 25
...

```

mandatory continuing professional education (MCPE) 255

...

## Version history

The [view](#) attribute was added in CEP 1.1.0. The optional [ce:intro](#) was introduced in CEP 1.1.1. Subelement [ce:section-title](#) was made optional in CEP 1.1.6.

## See also

[ce:index-entry](#), [ce:index-sec](#), [ce:see](#), [ce:see-also](#)

## ce:indexed-name

### Declaration

#### Model (CEPs 1.1.0–1.1.6)

```
<!ELEMENT ce:indexed-name ( %string.data; )*>
```

### Description

If the author's or collaboration's name is to be alphabetized differently than expected, the element `ce:indexed-name` is used.

### Usage

See `ce:author`.

### Version history

Prior to DTD 5.0, the element was called `index`.



## ce:index-entry

### Declaration

#### Model (CEPs 1.1.0–1.1.2)

```
<!ELEMENT ce:index-entry ( ce:index-heading, ( ce:see | ( %cross-
ref; )+ )? , ( ce:see-also | ce:index-
entry )* )>
<!ATTLIST ce:index-entry
  id ID #IMPLIED
  role CDATA #IMPLIED>
```

#### Model (CEP 1.1.3)

```
<!ELEMENT ce:index-entry ( ce:index-heading, ( ( %see; ) |
( %cross-ref; )+ )? , ( ce:see-also |
ce:index-entry | ce:reader-see )* )>
<!ATTLIST ce:index-entry
  id ID #IMPLIED
  role CDATA #IMPLIED>
```

#### Model (CEPs 1.1.4–1.1.6)

```
<!ELEMENT ce:index-entry ( ce:indexed-name?, ce:index-heading,
( %index-entry-refs; )? , ( ce:see-also
| ce:index-entry | ce:reader-see )* )>
<!ATTLIST ce:index-entry
  id ID #IMPLIED
  role CDATA #IMPLIED>
```

### Description

Every index entry is captured using `ce:index-entry`.

### Usage

The element `ce:index-entry` consists of an optional `ce:indexed-name` with the term under which the entry should appear in an index, a `ce:index-heading`, which is optionally followed by a “see” reference to another index entry (`ce:see`) or a number of cross-references, optionally followed by a mixture of “see-also” references to other index entries (`ce:see-also`), sub-index entries and general references (`ce:reader-see`).

The cross-references can be either a `ce:cross-ref` or a `ce:intra-ref`. The latter is to be used for referencing to documents that are part of a set, for instance a major reference work. For some examples, see `ce:see` and `ce:see-also`.

### Version history

Parameter entity `%see;` and element `ce:reader-see` were introduced in CEP 1.1.3.

Parameter entity `%index-entry-refs;` and element `ce:indexed-name` were introduced in CEP 1.1.4.

### See also

`ce:index`, `ce:see`, `ce:see-also`, `ce:reader-see`

## ce:index-flag

### Declaration

#### Model (CEPs 1.1.0–1.1.6)

```
<!ELEMENT ce:index-flag          ( ce:index-flag-term, ce:index-flag-
                                see?, ( ce:index-flag-see-also |
                                ce:index-flag )* )>
<!ATTLIST ce:index-flag
            id          ID          #REQUIRED
            role        CDATA       #IMPLIED>
```

### Description

The element `ce:index-flag` is envisioned for possible utilization by book indexers to use to aid in the to-be-developed process used to generate back-of-book indices.

### Usage

The element `ce:index-flag` allows a term to be marked for inclusion in an index. Its content model is closely related to that of `ce:index-entry`, and it is possible to generate an index entry from the flagged index term.

Content for element `ce:index-flag` consists of a required element `ce:index-flag-term`, followed by optional/repeatable `ce:index-flag-see` and/or `ce:index-flag-see-also` and/or nested `ce:index-flag` elements.

The element `ce:index-flag` has one required attribute, `id`.

#### XML

```
<ce:para>One of the enemies of the ant is the
aardvark<ce:index-flag id="a1234">
  <ce:index-flag-term>aardvark</ce:index-flag-term>
  <ce:index-flag-see-also>anteater</ce:index-flag-see-also>
</ce:index-flag> ...
</ce:para>
```

Secondary index terms are markup up as nested `ce:index-flag` elements.

#### XML

```
<ce:caption><ce:simple-para>Oberkörperhochlagerung bei
Herzinsuffizienz<ce:index-flag id="idx0040">
  <ce:index-flag-term>Lagerung</ce:index-flag-term>
  <ce:index-flag id="idx0041">
    <ce:index-flag-term>bei Herzinsuffizienz</ce:index-flag-term>
  </ce:index-flag>
</ce:index-flag> [A400]</ce:simple-para></ce:caption>
```

Because the element `ce:index-flag` has an ID, it can (and should) be the target of a `ce:intra-ref` element in the Index. This gives the possibility that in a hyperlinked PDF or HTML file, the reader can click on the entry terms in the Index and reach the exact location in the text. Without `ce:index-flag` elements the targets are at paragraph level.

*XML*

```
<ce:index-entry id="idx1260">
  <ce:index-heading>Lagerung</ce:index-heading>
  <ce:index-entry id="idx1270">
    <ce:index-heading>bei Herzinsuffizienz</ce:index-heading>
    <ce:intra-ref
      xlink:href="pii:B978-3-437-46192-7.10014-2#idx0041"
    >19</ce:intra-ref>
  </ce:index-entry>
</ce:index-entry>
```

**Version history**

This element was introduced in CEP 1.1.0.

**Rendering notes**

This element should not be rendered in either electronic or hardcopy versions of the book.

Web platforms may use the [ce:index-flag](#) element to generate additional, hyperlinked, indexes, for example, per chapter, or for a selected set of chapters or volumes.

## ce:index-flag-see

### Declaration

#### Model (CEPs 1.1.0–1.1.6)

```
<!ELEMENT ce:index-flag-see ( %text.data; )*>
```

### Description

The element `ce:index-flag-see` is used to delimit a term to be indexed, within the content model of the `ce:index-flag` element.

### Usage

Within `ce:index-flag`, the element `ce:index-flag-see` is used to create a “see” entry. This corresponds to a `ce:see` within an index entry.

#### XML

```
<ce:para>text text ...
  <index-flag id="a1234">
    <index-flag-term>acquired immune deficiency syndrome</index-flag-term>
    <index-flag-see>AIDS</index-flag-see>
  </index-flag> ... end of paragraph.
</ce:para>
```

### Version history

This element was introduced in CEP 1.1.0.

### See also

[ce:index-flag](#)

## ce:index-flag-see-also

### Declaration

#### Model (CEPs 1.1.0–1.1.6)

```
<!ELEMENT ce:index-flag-see-also( %text.data; )*>
```

### Description

The element [ce:index-flag-see-also](#) is used to delimit a term to be indexed, within the content model of the index-flag element.

### Usage

In order to flag a term for a “see also” index entry, the element [ce:index-flag-see-also](#) is used. It corresponds to a [ce:see-also](#) within an index entry.

See [ce:index-flag](#) for a usage example.

### Version history

This element was introduced in CEP 1.1.0.

## ce:index-flag-term

### Declaration

#### Model (CEPs 1.1.0–1.1.6)

```
<!ELEMENT ce:index-flag-term ( %text.data; )*>
```

### Description

The element `ce:index-flag-term` is used to delimit a term to be indexed, within the content model of the `ce:index-flag` element.

### Usage

The `ce:index-flag-term` contains the term to be indexed within a `ce:index-flag` element. It corresponds with the `ce:index-heading` within a `ce:index-entry`.

Content for `index-flag-term` consists of the `text.data` parameter entity from the Common Element Pool (CEP). See `ce:index-flag` for a usage example.

### Version history

This element was introduced in CEP 1.1.0.

## ce:index-heading

### Declaration

#### Model (CEPs 1.1.0–1.1.6)

```
<!ELEMENT ce:index-heading ( %textref.data; )*>
```

### Description

The heading of an index entry is captured using [ce:index-heading](#).

### Usage

Each index entry starts with a descriptive text, the heading.

For some examples, see [ce:see](#) and [ce:see-also](#).

### See also

[ce:index](#), [ce:index-entry](#), [ce:see](#), [ce:see-also](#)

## ce:index-sec

### Declaration

#### Model (CEPs 1.1.0–1.1.5)

```
<!ELEMENT ce:index-sec          ( ce:section-title?, ce:intro?,
                                ce:index-entry+ )>
<!ATTLIST ce:index-sec
           id             ID             #IMPLIED
           role          CDATA          #IMPLIED>
```

#### Model (CEP 1.1.6)

```
<!ELEMENT ce:index-sec          ( ce:section-title?, ce:intro?,
                                ce:index-entry+ )>
<!ATTLIST ce:index-sec
           id             ID             #IMPLIED
           role          CDATA          #IMPLIED
           view          %view;         'all'>
```

### Description

The element `ce:index-sec` is a section within the index.

### Usage

See `ce:index`.

### Version history

The `view` attribute was added in CEP 1.1.6.



## ce:inf

### Declaration

#### Model (CEPs 1.1.0–1.1.6)

```
<!ELEMENT ce:inf ( %richstring.data; )*>
<!ATTLIST ce:inf
  loc %loc; "post">
```

### Description

Subscripts are captured using `ce:inf`.

### Usage

Subscripts (inferior text) are captured using `ce:inf`.

The optional attribute `loc` can have the values `pre` and `post`, the latter is equivalent to omitting the attribute altogether. If `loc` is equal to `pre` this is to signify that the element belongs to the subsequent object.

*XML*

```
<ce:sup loc="pre">238</ce:sup><ce:inf loc="pre">92</ce:inf>U
```

*Presentation*

$${}^{238}{}_{92}\text{U}$$

By default, a super- and subscript appearing at one object will be displayed stacked, i.e. above each other. Staggered super- and subscripts (for example,  $R_j^i{}^k$ ) can only be used in [math mode](#).

### See also

[ce:sup](#)

## ce:initials

### Declaration

#### Model (CEPs 1.1.0–1.1.6)

```
<!ELEMENT ce:initials ( %string.data; )*>
```

### Description

In order to assist applications that need to determine the correct initials based on the given name, the element `ce:initials` has been provided. It is only used if the initials cannot be inferred from the given name by taking the first letters, preserving dashes.

The element is used by applications that want initials in running heads or in tables of content rather than the full given name.

Note that `ce:initials` does not replace `ce:given-name` if the author only supplied initials.

*XML*

```
<ce:author>
  <ce:initials>J.W.Th.</ce:initials>
  <ce:given-name>Joannes Wilhelmus Theodorus</ce:given-name>
  ...
</ce:author>
```

### Usage

See `ce:author`.

### Version history

Prior to DTD 5.0, the element was called `inits`.

## ce:inline-figure

### Declaration

#### Model (CEPs 1.1.0–1.1.6)

```
<!ELEMENT ce:inline-figure ( ce:link )>
<!ATTLIST ce:inline-figure
  baseline NMTOKEN "0.0">
```

### Description

The element `ce:inline-figure` is used to insert an image in the running text, e.g. a symbol that does not occur in the standard character set.

### Usage

An in-line figure, also less accurately known as fixed graphic, is a figure that occurs exactly at the point where it occurs in the document instance. It consists of one `ce:link` element, which refers to the external artwork file.

The bounding box of an in-line figure is as tight as possible. The vertical position of the in-line figure is controlled by the attribute `baseline`, whose default value is 0.0. It denotes the fraction of the height that appears below the baseline.

#### XML

```
A<ce:inline-figure baseline="0.33">
  <ce:link locator="fx1"/></ce:inline-figure>&Omega;
```

#### Presentation

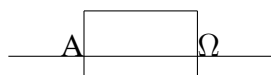

#### Explanation

Since the value of `baseline` is 0.33, the baseline is at one-third of the in-line figure, represented by the box, i.e., one-third of the graphic is below the baseline.

An inline-figure appears in the running text like a character would do. No spaces or new-lines are generated before or after an in-line figure. This makes it different from a displayed figure which appears on a line of its own with vertical space above and below it, see `ce:figure`. The graphic file is shown as is, i.e. it will not adapt to the surrounding font size or style, as would a `ce:glyph`.

In-line figures should not occur too deeply in the parse tree of the document.

### Version history

Prior to DTD 5.0, this element was called `inline-fig`.

### See also

[ce:figure](#), [ce:glyph](#)

## ce:inter-ref

### Declaration

#### Model (CEPs 1.1.0–1.1.6)

```
<!ELEMENT ce:inter-ref ( %text.data; )*>
<!ATTLIST ce:inter-ref
  id ID #IMPLIED
  xlink:type ( simple ) #FIXED "simple"
  xlink:role CDATA #IMPLIED
  xlink:href CDATA #REQUIRED>
```

### Description

The `ce:inter-ref` element is used to reference an object “not under control of the publisher”. Examples are HTML pages on the World-Wide Web, records in third-party on-line databases. The `ce:inter-ref` element is a simple link according to the XLink standard.

### Usage

The `ce:inter-ref` is a versatile element used to refer to foreign objects. Its content is popularly seen as “text to click on”, but it may be empty.

The attribute `xlink:href` determines the actual link. Its value is a URI-reference (URI: Universal Resource Identifier) according to [RFC2396](#). The URI-reference consists of three parts:

- the protocol or scheme, which is the part up to the colon; the allowed schemes are documented below;
- the resource identifier, which is the part from the colon to the end or up to the hash sign; in the text below we will refer to it as the locator;
- the fragment identifier, which is the part after the hash sign; it may be an ID in the target document, or a more complicated XPath expression; the fragment identifier is optional.

For rules regarding the encoding of URI-references, see the sections on rendering and copy edit considerations below.

The attribute `xlink:role` is used to indicate what kind of object is to be expected at the other end of the link. Its value is a URI of the form

```
http://www.elsevier.com/xml/linking-roles/<role name>.
```

Currently, there are only three role names: “preprint”, “inspec”, and any MIME type.

A number of schemes to be used in `xlink:href` are documented. For each value of the scheme different rules may apply. These are described below.

#### The scheme in `xlink:href` is equal to *aoi*

The locator is an astronomical object identifier (aoi). It consists of the doi of the article, followed by the text `&` or `&#x0026;`, followed by the agreed object name. No roles are to be specified. Note that, if there is a space in the aoi, it is encoded as `%20`.

XML

```
<ce:inter-ref id="interref1"
  xlink:href="aoi:10.1016/j.newast.2003.11.001&#x0026;CF%20Pup"> ☺
  CF Pup</ce:inter-ref>
```

**The scheme in *xlink:href* is equal to *doi***

The locator is a [digital object identifier](#) (DOI, see [www.doi.org](http://www.doi.org)). No roles are to be specified. The path may contain an ID within the target document, in the form of a fragment identifier.

```
XML
<ce:inter-ref id="interref2"
  xlink:href="doi:10.1016/S0004-3702(02)00193-5">...</ce:inter-ref>
```

**Standards Note:** The doi scheme is officially recognized as part of the [info](#) URI scheme. In this scheme the above [xlink:href](#) would become

```
xlink:href="info:doi:10.1016/S0004-3702(02)00193-5"
```

The form according to the [info](#) URI scheme is not (yet) allowed in the Common Element Pool.

**The scheme in *xlink:href* is equal to *fiz***

The locator addresses a document in the [FIZ](#) database ([www.fiz-karlsruhe.de](http://www.fiz-karlsruhe.de)). The attribute [xlink:role](#) is mandatory here; currently the only allowed value is `inspec` (denoting an `inspec` record). Note that the colon in the FIZ code is encoded as `%3A`.

```
XML
<ce:inter-ref id="interref3"
  xlink:role="http://www.elsevier.com/xml/linking-roles/inspec"
  xlink:href="fiz:85%3A2535122">...</ce:inter-ref>
```

**The scheme in *xlink:href* is equal to *genbank***

The locator is a Genbank accession number, assigned by the NIH genetic sequence database (an annotated collection of all publicly available DNA sequences, [www.ncbi.nlm.nih.gov](http://www.ncbi.nlm.nih.gov)). No roles are to be specified. This scheme will be deprecated by July 2009. This scheme is replaced by the scheme "ncbi-n".

```
XML
<ce:inter-ref id="interref4"
  xlink:href="genbank:AB026824">...</ce:inter-ref>
```

**Standards Note:** The genbank scheme is officially recognized as part of the [info](#) URI scheme under the name `ddbj-embl-genbank`. In this scheme the above [xlink:href](#) would become

```
xlink:href="info:ddbj-embl-genbank:AB026824"
```

The form according to the [info](#) URI scheme is not (yet) allowed in the Common Element Pool.

**Standards Note:** The Genbank accession numbers are accommodated by the [Life Sciences Identifier](#) (LSID), a proposed standard of the OMG. In this scheme the above [xlink:href](#) would become something like

```
xlink:href="URN:LSID:ncbi.nlm.nih.gov:GenBank.accession:AB026824"
```

The form according to the [LSID](#) URI scheme is not (yet) allowed in the Common Element Pool.

**The scheme in *xlink:href* is equal to *embl***

The locator is an EMBL accession number, assigned by the EMBL nucleotide sequence database, [www.ebi.ac.uk/embl](http://www.ebi.ac.uk/embl). No roles are to be specified.

XML

```
<ce:inter-ref id="interref4"
  xlink:href="embl:AB026824">...</ce:inter-ref>
```

The embl scheme is a synonym for the genbank scheme. Only the assigning authority is different.

XML

```
<ce:inter-ref id="interref5"
  xlink:href="pii:S0004-3702(02)00193-5">...</ce:inter-ref>
```

This scheme is used, for instance, if an editorial refers to articles in an issue.

**The scheme in *xlink:href* is equal to *http*, *https*, *ftp*, or *mailto***

The locator is a URL. Optionally a role can be specified: it must then be a MIME type. The path may contain a named location within the target document (this is the part which comes after the # in the HREF attribute of HTML's A element), in the form of a fragment identifier. http, ftp, and mailto are officially recognized URI schemes.

XML

```
<ce:inter-ref id="interref6"
  xlink:role="http://www.elsevier.com/xml/linking-roles/text/html"
  xlink:href="http://www.elsevier.com">Elsevier</ce:inter-ref>
```

XML

```
<ce:inter-ref id="interref7"
  xlink:href="mailto:r.schrauwen@elsevier.com">Ⓜ
  r.schrauwen@elsevier.com</ce:inter-ref>
```

**The scheme in *xlink:href* is equal to *arxiv***

The locator is an address of the arXiv.org e-Print archive ([www.arxiv.org](http://www.arxiv.org)). The attribute *xlink:role* is mandatory here; currently the only allowed value is preprint.

XML

```
<ce:inter-ref id="interref8"
  xlink:role="http://www.elsevier.com/xml/linking-roles/preprint"
  xlink:href="arxiv:/hep-th/9112009"></ce:inter-ref>
```

**The scheme in *xlink:href* is equal to *sid***

The locator holds the non-formatted PII of the article itself, a slash and the so-called anchortext corresponding to the enclosed structure reference. No roles are to be specified.

XML

```
<ce:inter-ref id="interref9"
  xlink:href="sid:S0040403901014216/2"><ce:bold>2</ce:bold>
</ce:inter-ref>
```

This scheme is used for Dymond linking (i.e. external object linking for chemical structures).

**The scheme in *xlink:href* is equal to *ctgov***

The locator is an NCT number, the National Library of Medicine's unique identifier for a record at [ClinicalTrials.gov](http://ClinicalTrials.gov). No roles are to be specified.

XML

```
<ce:inter-ref id="interref10"
  xlink:href="ctgov:NCT00222573">NCT00222573</ce:inter-ref>
```

**The scheme in *xlink:href* is equal to *omim***

The locator is an OMIM number which identifies a record in [Online Mendelian Inheritance in Man](#), a database containing a catalog of human genes and genetic disorders. No roles are to be specified.

*XML*

```
MIM <ce:inter-ref id="interref11"
  xlink:href="omim:601240">601240</ce:inter-ref>
```

Note that only the number is linked.

**The scheme in *xlink:href* is equal to *mint***

The locator is a MINT number which identifies a record in the [Molecular INTeraction database](#). No roles are to be specified. Example:

*XML*

```
MINT-<ce:inter-ref id="interref12"
  xlink:href="mint:6166710">6166710</ce:inter-ref>
```

Note that only the number is linked.

The http URL is constructed from the MINT URI by prepending the MINT number with: <http://mint.bio.uniroma2.it/mint/search/interaction.do?interactionAc=MINT->. The resulting link of the above example is:

*Presentation*

MINT-[6166710](#)

Note: This protocol is used in the FEBS structured summaries. There the string ‘MINT-’ is included in the content of the `ce:inter-ref` element.

**The scheme in *xlink:href* is equal to *uniprotkb***

The locator is a Uniprot number which identifies a record in [UniProtKB](#), the Universal Protein Resource Knowledgebase. No roles are to be specified. Example:

*XML*

```
uniprotkb:<ce:inter-ref id="interref13"
  xlink:href="uniprotkb:Q9H0H5">Q9H0H5</ce:inter-ref>
```

Note that only the number is linked.

The http URL is constructed from the UniProtKB URI by prepending the UniProtKB number with: <http://www.uniprot.org/uniprot/>. The resulting link of the above example is:

*Presentation*

uniprotkb:[Q9H0H5](#)

Note: This protocol is used in the FEBS structured summaries. There the content of the `ce:inter-ref` element is the name of the protein.

**The scheme in *xlink:href* is equal to *mi***

The locator is an MI number which identifies a record in the [EMBL-EBI IntAct database](#) for Molecular Interactions. No roles are to be specified. Example:

*XML*

```
MI:<ce:inter-ref id="interref14"
  xlink:href="mi:0218">0218</ce:inter-ref>
```

Note that only the number is linked.

The http URL is constructed from the MI URI by prepending the MI number with: <http://www.ebi.ac.uk/ontology-lookup/?termId=MI:>. The resulting link of the above example is:

*Presentation*

MI:[0218](#)

Note: This protocol is used in the FEBS structured summaries. There the content of the `ce:inter-ref` element is the name of the interaction.

#### The scheme in *xlink:href* is equal to *pdb*

The locator is a Worldwide Protein Data Bank accession number which identifies a record in the [Worldwide Protein Data Bank](#). Example:

*XML*

```
<ce:inter-ref id="interref15"
  xlink:href="pdb:2pmz">2pmz</ce:inter-ref>
```

The http URL for viewing the molecule in the FirstGlance tool is constructed from the pdb URI by prepending the pdb accession number with:

<http://firstglance.jmol.org/fg.htm?mol=>. The resulting link of the above example is:

*Presentation*

[2pmz](#)

#### The scheme in *xlink:href* is equal to *pmid*

The locator is a Pubmed ID which identifies an abstract at [Pubmed](#). No roles are to be specified. Example:

*XML*

```
PMID: <ce:inter-ref id="interref16"
  xlink:href="pmid:19011746">19011746</ce:inter-ref>
```

Note that only the number is linked.

The http URL for PMIDs is constructed from the pmid URI by prepending the PMID with: <http://www.ncbi.nlm.nih.gov/pubmed/>. The resulting link of the above example is:

*Presentation*

PMID: [19011746](#)

#### The scheme in *xlink:href* is equal to *ncbi-n*

The locator is a NCBI nucleotide accession number, assigned by the NIH genetic sequence database (an annotated collection of all publicly available DNA sequences, [www.ncbi.nlm.nih.gov](http://www.ncbi.nlm.nih.gov)). No roles are to be specified.

*XML*

```
<ce:inter-ref id="interref4"
  xlink:href="ncbi-n:AB026824">...</ce:inter-ref>
```



The http URL for NCBI nucleotide accession number is constructed by prepending the accession number with:

`http://www.ncbi.nlm.nih.gov/entrez/query.fcgi?cmd=search&db=nucleotide&doptcmdl=genbank&term=`. The resulting link of the above example is:

*Presentation*  
[AB026824](#)

**The scheme in *xlink:href* is equal to *ncbi-p***

The locator is a NCBI protein accession number, assigned by the NIH genetic sequence database (an annotated collection of all publicly available DNA sequences, [www.ncbi.nlm.nih.gov](http://www.ncbi.nlm.nih.gov)). No roles are to be specified.

*XML*  
`<ce:inter-ref id="interref4" xlink:href="ncbi-p:Q9JJS7">...</ce:inter-ref>`

The http URL for NCBI protein accession number is constructed by prepending the accession number with:

`http://www.ncbi.nlm.nih.gov/entrez/query.fcgi?cmd=search&db=protein&doptcmdl=genbank&term=`. The resulting link of the above example is:

*Presentation*  
[Q9JJS7](#)

**The scheme in *xlink:href* is equal to *ncbi-wgs***

The locator is a NCBI WGS accession number, assigned by the NIH genetic sequence database (an annotated collection of all publicly available DNA sequences, [www.ncbi.nlm.nih.gov](http://www.ncbi.nlm.nih.gov)). No roles are to be specified.

*XML*  
`<ce:inter-ref id="interref4" xlink:href="ncbi-wgs:AAAA01000001">...</ce:inter-ref>`

The http URL for NCBI WGS accession number is constructed by prepending the accession number with:

`http://www.ncbi.nlm.nih.gov/entrez/query.fcgi?cmd=search&db=nucleotide&doptcmdl=genbank&term=`. The resulting link of the above example is:

*Presentation*  
[AAAA01000001](#)

**The scheme in *xlink:href* is equal to *ncbi-mmdb***

The locator is a NCBI MMDB accession number, assigned by the NIH genetic sequence database (an annotated collection of all publicly available DNA sequences, [www.ncbi.nlm.nih.gov](http://www.ncbi.nlm.nih.gov)). No roles are to be specified.

*XML*  
`<ce:inter-ref id="interref4" xlink:href="ncbi-mmdb:50188">...</ce:inter-ref>`

The http URL for NCBI MMDB accession number is constructed by prepending the accession number with:

`http://www.ncbi.nlm.nih.gov/entrez/query.fcgi?cmd=search&db=structure&doptcmdl=genbank&term=`. The resulting link of the above example is:

*Presentation*  
50188

## Relation with DTD 4

Prior to DTD 5, `inter-ref` had three attributes: `locator-type`, `locator` and `object-type`.

`locator-type` corresponds to the scheme part of `xlink:href`. The schemes have the same names as the former `locator-type` attribute, except for `xxx-archive`, which now is called `arxiv`, in agreement with the change of name of the preprint service it refers to.

`locator` corresponds to the path part of `xlink:href`.

`object-type` corresponds to `xlink:role`. The roles have the same names as the former `object-type` attribute, prepended by the string

`http://www.elsevier.com/xml/linking-roles/`.

## XLink aspects

`ce:inter-ref` has an attribute `xlink:type` with the fixed value `simple`. This makes it into a simple link according to the XLink standard. The `xlink:href` and `xlink:role` attributes comply with the XLink requirements for a simple link. Thus `ce:inter-ref` can be processed by general XLink software.

## Rendering notes

If the rendering application cannot deal with `ce:inter-ref`, or the scheme in `xlink:href`, it should not complain and merely output the content of the element. If the content is empty, then the rendering application may provide another method to reach the destination, e.g. a button or a hyperlink containing the `xlink:href` attribute. The element `ce:inter-ref` does not generate any presentation.

## Decoding the URI

The value of the attribute `xlink:href` is a URI-reference. Therefore it is encoded according to the rules for URIs. It is also XML encoded. The URI-encoded `xlink:href` values can be used in web products as follows.

First the XML encoding (character entities) must be resolved, which is automatically done by parsers and other XML tools.

In the `http`, `ftp`, or `mailto` schemes the `xlink:href` values are URLs or email addresses. They can be used directly as URLs in web products.

In the other schemes the `xlink:href` values are not URLs. When URLs are constructed from these values, they must be properly encoded. The identifiers in the `xlink:href` values may contain special characters, esp. `&` and `?`. These characters have a reserved meaning in a URL. Therefore they must be escaped as `%26` and `%3F`.

For example, the following is (theoretically) a valid `xlink:href` value:

`doi:10.1049/S0004&3702(02)00193?5`

But the following URL, derived from it, is not valid:

```
http://dx.doi.org/10.1049/S0004&3702(02)00193?5
```

The valid form of the derived URL is

```
http://dx.doi.org/10.1049/S0004%263702(02)00193%3F5
```

### Linking services

The `xlink:href` attribute uses a number of privately defined schemes, which can only be resolved by special algorithms containing knowledge of the specific scheme. Often such an algorithm resolves the `ce:inter-ref` element to a hyperlink on the web with an http URL. Collections of such resolved hyperlinks may be held in linking services. The links in such services are so-called third-party links, one end of which is the `ce:inter-ref` element in the article, the other end being the resolved URL. To make it easier to use a `ce:inter-ref` element as a link end for such third-party links, it has a required ID attribute.

### Copy edit considerations

The value of the attribute `xlink:href` is a URI-reference. Therefore it must be encoded according to the rules for URIs. After its URI-encoded form has been determined, it must also be XML encoded, i.e., the XML-reserved characters must be encoded as character entities, esp. `&`, must be encoded as `&amp;`.

In the `http`, `ftp`, or `mailto` schemes the `xlink:href` values are URLs or email addresses. It may be assumed that the URL as given by the author in the manuscript is correct, and can be inserted as is in the XML file, after XML encoding (esp. `&`).

It is useful to check whether the general form of the URL is correct. `http` and `ftp` URLs have the following general form:

```
http://server.domain.cy/path/to/file?arg1=value1&arg2=value2#name
```

where the CGI arguments (the part between the `?` and the `#`) and the fragment identifier (the part after the `#`) are optional. A `mailto` email address has the following general form:

```
mailto:i.person@domain.cy
```

For the other URI schemes, `aoi`, `doi`, `fiz`, `genbank`, `pii`, `arxiv`, and `sid`, usually only the identifier is given in the manuscript, and the proper URI form must be determined. The following rules are applicable.

- The URI-encoded form of the identifier may only consist of alphanumeric characters and characters from the set  
`"-" | "_" | "." | "!" | "~" | "*" | ":" | "(" | ")"`
- In addition, in URIs of the `doi`, `arxiv`, and `sid` schemes, the character `/` may appear, as follows:  
*doi.* doi:10.publid/identifier  
*arxiv.* arxiv:/category/number  
*sid.* sid:pii/fid
- All other characters must be escaped. The escaped form is of the form `%hex`, where `hex` denotes the hexadecimal ASCII value of the character, e.g. `%3A` for the colon and `%20` for the space.

For example, the FIZ identifier 85:2535122 and the astronomical object ‘LC 123’ must be marked up with the following `xlink:href` values:

```
xlink:href="fiz:85%3A2535122"
```

```
xlink:href="aoi:LC%20123"
```

## Version history

As of CEP 1.1.5, the inter-ref scheme `pii` is deprecated.

## See also

[ce:cross-ref](#), [ce:cross-refs](#), [ce:inter-refs](#), [ce:intra-ref](#), [ce:intra-refs](#)

## ce:inter-ref-end

### Declaration

#### Model (CEPs 1.1.0–1.1.6)

```
<!ELEMENT ce:inter-ref-end ( ce:inter-ref-title? )>
<!ATTLIST ce:inter-ref-end
  xlink:type ( locator ) #FIXED "locator"
  xlink:label ( inter-ref-end ) #FIXED "inter-ref-end"
  xlink:role CDATA #IMPLIED
  xlink:href CDATA #REQUIRED>
```

### Description

Each [ce:inter-ref-end](#) element denotes a link target within an [ce:inter-refs](#) element.

### Usage

See [ce:inter-refs](#)

## ce:inter-ref-title

### Declaration

#### Model (CEPs 1.1.0–1.1.6)

```
<!ELEMENT ce:inter-ref-title ( %text.data; )*>
<!ATTLIST ce:inter-ref-title
  xlink:type ( title ) #FIXED "title">
```

### Description

The `ce:inter-ref-title` element contains the text for one destination, to show for the parent `ce:inter-ref-end` element when multiple links are shown in a selection list.

### Usage

See `ce:inter-refs`.

## ce:inter-refs

### Declaration

#### Model (CEPs 1.1.0–1.1.6)

```
<!ELEMENT ce:inter-refs      ( ce:inter-refs-text?, ce:inter-ref-
                             end+, ce:inter-refs-link )>
<!ATTLIST ce:inter-refs
          xlink:type          ( extended )      #FIXED "extended">
```

### Description

The `ce:inter-refs` element is the one-to-many-links version of `ce:inter-ref`, *q.v.* It is an extended link according to the XLink standard.

### Usage

The `ce:inter-refs` element contains a `ce:inter-refs-text` element, one or more `ce:inter-ref-end` elements and a `ce:inter-refs-link` element.

The `ce:inter-refs-text` element contains the text that is popularly seen as “text to click on”; it may be absent. It is the text seen in a rendering of the document, e.g. “Parts I–IV”. Both the hyperlinks to the individual destinations and descriptive labels (e.g., “Part III”) are included in the other subelements of the parent `ce:inter-refs`.

Each `ce:inter-ref-end` element denotes a link target. Its attribute `xlink:href` determines the actual link. Its attribute `xlink:role` is used to indicate what kind of object is to be expected at the other end of the link. Both attributes follow the same rules as the attributes of the same name of `ce:inter-ref`, *q.v.* The subelement `ce:inter-ref-end` contains an optional `ce:inter-ref-title` element, whose content is the text to show for this link when multiple links are shown in a selection list.

The `ce:inter-refs-link` element is empty. Its presence is required by the XLink standard.

#### XML

```
<ce:inter-refs>
  <ce:inter-refs-text id="interref3">Ⓢ
    AI631510&ndash;AI631512</ce:inter-refs-text>
  <ce:inter-ref-end xlink:href="genbank:AI631510">
    <ce:inter-ref-title>AI631510</ce:inter-ref-title>
  </ce:inter-ref-end>
  <ce:inter-ref-end xlink:href="genbank:AI631511">
    <ce:inter-ref-title>AI631511</ce:inter-ref-title>
  </ce:inter-ref-end>
  <ce:inter-ref-end xlink:href="genbank:AI631512">
    <ce:inter-ref-title>AI631512</ce:inter-ref-title>
  </ce:inter-ref-end>
  <ce:inter-refs-link/>
</ce:inter-refs>
```

#### Presentation

[AI631510–AI631512](#) (in the PDF file)  
[AI631510](#), [AI631511](#) and [AI631512](#) (in a fictive online environment)

## XLink aspects

`ce:inter-refs` has an attribute `xlink:type` with the fixed value `extended`. This makes it into an extended link according to the XLink standard. Its child elements also have several fixed `xlink` attributes, which determine their XLink meaning, in compliance with the XLink standard. Thus `ce:inter-refs` can be processed by general XLink software.

The same example, with all fixed attributes shown explicitly:

*XML*

```
<ce:inter-refs xlink:type="extended">
  <ce:inter-refs-text id="interref3" xlink:type="resource"
    xlink:label="inter-refs-start">
    AI631510&ndash;AI631512</ce:inter-refs-text>
  <ce:inter-ref-end xlink:type="locator"
    xlink:label="inter-ref-end" xlink:href="genbank:AI631510">
    <ce:inter-ref-title
      xlink:type="title">AI631510</ce:inter-ref-title>
  </ce:inter-ref-end>
  <ce:inter-ref-end xlink:type="locator"
    xlink:label="inter-ref-end" xlink:href="genbank:AI631511">
    <ce:inter-ref-title
      xlink:type="title">AI631511</ce:inter-ref-title>
  </ce:inter-ref-end>
  <ce:inter-ref-end xlink:type="locator"
    xlink:label="inter-ref-end" xlink:href="genbank:AI631512">
    <ce:inter-ref-title
      xlink:type="title">AI631512</ce:inter-ref-title>
  </ce:inter-ref-end>
  <ce:inter-refs-link xlink:type="arc"
    xlink:from="inter-refs-start" xlink:to="inter-ref-end"/>
</ce:inter-refs>
```

Its interpretation in terms of the XLink standard is as follows. A link is indicated from the current position (the local resource) to some other positions not in this document (the remote resources).

The `ce:inter-refs-text` element is the local resource, which is indicated by its attribute `xlink:type="resource"`.

The `ce:inter-ref-end` elements are the remote resources, which is indicated by their `xlink:type="locator"` attribute.

The actual links are created by the `ce:inter-refs-link` element, which is indicated by its `xlink:type="arc"` attribute. It links from `xlink:from="inter-refs-start"` to `xlink:to="inter-ref-end"`. The former points to the `ce:inter-refs-text` element, which has the `xlink:label="inter-refs-start"` attribute. The latter points to both `ce:inter-ref-end` elements, which both have the `xlink:label="inter-ref-end"` attribute.

Each of the `ce:inter-ref-end` elements has an optional `ce:inter-ref-title` element, with an `xlink:type="title"` attribute. They serve as a human readable title of the `ce:inter-ref-end` element, making it easier for applications to create the selection list for one-to-many links.



**Linking services**

The same considerations regarding linking services apply as for [ce:inter-ref](#), *q.v.* The [ce:inter-ref-title](#) has a required ID attribute, since it is the local resource, which can be the link end of third-party links.

**Rendering notes**

The text contained in [ce:inter-refs-text](#) appears in any rendering. The destinations contained in [ce:inter-ref-title](#) can be used to obtain a selection list.

**See also**

[ce:cross-ref](#), [ce:cross-refs](#), [ce:inter-ref](#)

## ce:inter-refs-link

### Declaration

#### Model (CEPs 1.1.0–1.1.6)

```
<!ELEMENT ce:inter-refs-link EMPTY>
<!ATTLIST ce:inter-refs-link
  xlink:type ( arc ) #FIXED "arc"
  xlink:from ( inter-refs-start )
  xlink:to ( inter-ref-end ) #FIXED "inter-ref-end">
```

### Description

The `ce:inter-refs-link` element is empty. Its presence in `ce:inter-refs` is required by the XLink standard.

### Usage

See `ce:inter-refs`.

## ce:inter-refs-text

### Declaration

#### Model (CEPs 1.1.0–1.1.6)

```
<!ELEMENT ce:inter-refs-text ( %text.data; )*>
<!ATTLIST ce:inter-refs-text
  id ID #IMPLIED
  xlink:type ( resource ) #FIXED "resource"
  xlink:label ( inter-refs-start )
  #FIXED "inter-refs-start">
```

### Description

The `ce:inter-refs-text` element contains the text that is popularly seen as “text to click on” within a `ce:inter-refs` element. Clicking on this text may lead to more than one destination.

### Usage

See `ce:inter-refs`.

## ce:intra-ref

### Declaration

#### Model (CEPs 1.1.0–1.1.6)

```
<!ELEMENT ce:intra-ref ( %text.data; )*>
<!ATTLIST ce:intra-ref
  id ID #IMPLIED
  xlink:type ( simple ) #FIXED "simple"
  xlink:role CDATA #IMPLIED
  xlink:href CDATA #REQUIRED>
```

### Description

The `ce:intra-ref` element is used to reference an object “under control of the publisher”. Examples are cross-references to destinations within other chapters of the same book. The `ce:intra-ref` element is a simple link according to the XLink standard.

### Usage

The `ce:intra-ref` element is a versatile element used to refer to foreign objects under control of the publisher. Its content is popularly seen as “text to click on”, but it may be empty. The target, given in the attribute `xlink:href` must be outside the document that contains `ce:intra-ref`.

An example is a cross-reference to a section in another chapter of a book. The element `ce:cross-ref` cannot be used, since the destination ID must be in the same file.

While `ce:inter-ref` takes the user out of the application, `ce:intra-ref` remains within the realm of the application; in practice, the destination will be within the same book or serial issue. In such cases, the XML validation tools, run on the whole collection of files belonging to the book, check that the destination IDs exist. However, the application must not assume that the target is in existence in the application. The application activates the link when the target document is present.

The attribute `xlink:href` determines the actual link. The attribute `xlink:role` is used to indicate what kind of object is to be expected at the other end of the link. Both attributes follow the same general rules as the attributes of the same name of `ce:inter-ref`, *q.v.* In the element `ce:intra-ref` there is only one valid value for the scheme in `xlink:href`: `pii`. This scheme does not allow a value for the `xlink:role` attribute.

XML

```
<ce:intra-ref id="intraref1"
  xlink:href="pii:S0140-6736(05)70368-8">...</ce:intra-ref>
```

The `pii` scheme is most commonly used for referring to destinations *within* other chapters of the same book. The destination ID is found after the #.

XML

```
<ce:intra-ref id="intraref2"
  xlink:href="pii:S0004-3702(02)00193-5">...</ce:intra-ref>
```

XML

```
<ce:intra-ref id="intraref3"
  xlink:href="pii:S0004-3702(02)00193-5#sec7">...</ce:intra-ref>
```

### Relation with DTD 4

The element `intra-ref` of DTD 4.3 and earlier was used in the context of linked textboxes. Since linked textboxes are now an integral part of the item, `ce:cross-ref` can be used for that purpose.

### XLink aspects

`ce:intra-ref` has an attribute `xlink:type` with the fixed value `simple`. This makes it into a simple link according to the XLink standard. The `xlink:href` and `xlink:role` attributes comply with the XLink requirements for a simple link. Thus `ce:intra-ref` can be processed by general XLink software. For more information, see `ce:inter-ref`.

### Rendering notes

If the rendering application cannot deal with `ce:intra-ref`, or the scheme in `xlink:href`, it should not complain and merely output the content of the element. If the content is empty, then the rendering application may provide another method to reach the destination, e.g. a button or a hyperlink containing the `xlink:href` attribute. The element `ce:intra-ref` does not generate any presentation.

### Version history

Prior to DTD 5.0, `intra-ref` used a location mechanism based on entities. It was only useful for cross-referencing between linked textboxes and the main document. Linked textboxes are now included in the main file itself, and the usage has changed to cross-references between book chapters, indexes, etc.

As of CEP 1.1.5, the `intra-ref` scheme `doi` is deprecated.

### See also

`ce:cross-ref`, `ce:cross-refs`, `ce:inter-ref`, `ce:inter-refs`, `ce:intra-refs`

## ce:intra-ref-end

### Declaration

#### Model (CEPs 1.1.0–1.1.6)

```
<!ELEMENT ce:intra-ref-end ( ce:intra-ref-title? )>
<!ATTLIST ce:intra-ref-end
  xlink:type ( locator ) #FIXED "locator"
  xlink:label ( intra-ref-end ) #FIXED "intra-ref-end"
  xlink:role CDATA #IMPLIED
  xlink:href CDATA #REQUIRED>
```

### Description

Each [ce:intra-ref-end](#) element denotes a link target within an [ce:intra-refs](#) element.

### Usage

See [ce:intra-refs](#).

## ce:intra-ref-title

### Declaration

#### Model (CEPs 1.1.0–1.1.6)

```
<!ELEMENT ce:intra-ref-title ( %text.data; )*>
<!ATTLIST ce:intra-ref-title
  xlink:type ( title ) #FIXED "title">
```

### Description

The `ce:intra-ref-title` element contains the text for one destination, to show for the parent `ce:intra-ref-end` element when multiple links are shown in a selection list.

### Usage

See `ce:intra-refs`.

## ce:intra-refs

### Declaration

#### Model (CEPs 1.1.0–1.1.6)

```
<!ELEMENT ce:intra-refs          ( ce:intra-refs-text, ce:intra-ref-end+,
                                ce:intra-refs-link )>
<!ATTLIST ce:intra-refs
          xlink:type          ( extended )          #FIXED "extended">
```

### Description

The `ce:intra-refs` element is the one-to-many-links version of `ce:intra-ref`, *q.v.* It is an extended link according to the XLink standard.

### Usage

The function of the element `ce:intra-refs` is identical to `ce:inter-refs`, but the existence of the destinations is guaranteed. This is similar to the simple-link variant `ce:intra-ref`.

The `ce:intra-refs` element contains a `ce:intra-refs-text` element, one or more `ce:intra-ref-end` elements and a `ce:intra-refs-link` element.

The `ce:intra-refs-text` element contains the text that is popularly seen as “text to click on”; it may be absent. It is the text seen in a rendering of the document, e.g. “[37, Sections 7–10]”. Both the hyperlinks to the individual destinations and descriptive labels (e.g., “[37, Section 9]”) are included in the other subelements of the enclosing `ce:intra-refs`.

Each `ce:intra-ref-end` element denotes a link target. Its attribute `xlink:href` determines the actual link. Its attribute `xlink:role` is used to indicate what kind of object is to be expected at the other end of the link. Both attributes follow the same rules as the attributes of the same name of `ce:intra-ref`, *q.v.* The subelement `ce:intra-ref-end` contains an optional `ce:intra-ref-title` element, whose content is the text to show for this link when multiple links are shown in a selection list.

The `ce:intra-refs-link` element is empty. Its presence is required by the XLink standard.

#### XML

```
<ce:intra-refs>
  <ce:intra-refs-text id="intraref8">Figs. 1 and 2
    in Chapter 2</ce:intra-refs-text>
  <ce:intra-ref-end xlink:href="pii:S0167-8396(00)00009-1#fig1">
    <ce:intra-ref-title>Fig. 1</ce:intra-ref-title>
  </ce:intra-ref-end>
  <ce:intra-ref-end xlink:href="pii:S0167-8396(00)00009-1#fig2">
    <ce:intra-ref-title>Fig. 2</ce:intra-ref-title>
  </ce:intra-ref-end>
  <ce:intra-refs-link/>
</ce:intra-refs>
```



### **XLink aspects**

`ce:intra-refs` has an attribute `xlink:type` with the fixed value `extended`. This makes it into an extended link according to the XLink standard. Its child elements also have several fixed `xlink` attributes, which determine their XLink meaning, in compliance with the XLink standard. Thus `ce:intra-refs` can be processed by general XLink software. Please refer to `ce:inter-refs`, where a more detailed illustration is given.

### **Linking services**

The same considerations regarding linking services apply as for `ce:intra-ref`, *q.v.* The `ce:intra-ref-title` has a required ID attribute, since it is the local resource, which can be the link end of third-party links.

### **Rendering notes**

The text contained `ce:inter-refs-text` appears in any rendering. The destinations contained in `ce:inter-ref-title` can be used to obtain a selection list.

### **See also**

`ce:cross-ref`, `ce:cross-refs`, `ce:inter-ref`, `ce:inter-refs`, `ce:intra-ref`

## ce:intra-refs-link

### Declaration

#### Model (CEPs 1.1.0–1.1.6)

```
<!ELEMENT ce:intra-refs-link EMPTY>
<!ATTLIST ce:intra-refs-link
  xlink:type ( arc ) #FIXED "arc"
  xlink:from ( intra-refs-start )
  xlink:to ( intra-ref-end ) #FIXED "intra-ref-end">
```

### Description

The `ce:intra-refs-link` element is empty. Its presence in `ce:intra-refs` is required by the XLink standard.

### Usage

See `ce:intra-refs`.

## ce:intra-refs-text

### Declaration

#### Model (CEPs 1.1.0–1.1.6)

```
<!ELEMENT ce:intra-refs-text ( %text.data; )*>
<!ATTLIST ce:intra-refs-text
  id ID #IMPLIED
  xlink:type ( resource ) #FIXED "resource"
  xlink:label ( intra-refs-start )
  #FIXED "intra-refs-start">
```

### Description

The `ce:intra-refs-text` element contains the text that is popularly seen as “text to click on” within a `ce:intra-refs` element. Clicking on this text may lead to more than one destination.

### Usage

See `ce:intra-refs`.

## ce:intro

### Declaration

#### Model (CEPs 1.1.0–1.1.5)

```
<!ELEMENT ce:intro ( ce:para+ )>
```

#### Model (CEP 1.1.6)

```
<!ELEMENT ce:intro ( ce:para+ )>
<!ATTLIST ce:intro
  id ID #IMPLIED
  role CDATA #IMPLIED
  view %view; 'all'>
```

### Description

The element `ce:intro` contains a brief introduction.

### Usage

The element `ce:intro` consists of one or more paragraphs, `ce:para`. It is used for short introductory paragraphs, e.g. in an index, glossary or textbox.

### Version history

The `id`, `role` and `view` attributes were added in CEP 1.1.6.

## ce:isbn

### Declaration

#### Model (CEPs 1.1.0–1.1.6)

```
<!ELEMENT ce:isbn ( %string.data; )*>
```

### Description

The element `ce:isbn` is available to uniquely identify a book project.

### Usage

The element `ce:isbn` is used in the identification portions of books DTDs to identify the book project. It contains the ISBN or ISBN-13 in its formatted form.

*XML*

```
<ce:isbn>0-13-065567-8</ce:isbn>  
<ce:isbn>978-0-13-065567-7</ce:isbn>
```

### Version history

This element was added in CEP 1.1.0.

## ce:issn

### Declaration

#### Model (CEPs 1.1.0–1.1.6)

```
<!ELEMENT ce:issn ( %string.data; )*>
```

### Description

The element `ce:issn` is available to uniquely identify a serial publication, e.g. a journal.

### Usage

The element `ce:issn` is used in the identification portions of serial publications, and contains an ISSN in its formatted form.

*XML*

```
<ce:issn>0369-8114</ce:issn>
```

### Version history

This element was added in CEP 1.1.0.

## ce:italic

### Declaration

#### Model (CEPs 1.1.0–1.1.6)

```
<!ELEMENT ce:italic          ( %richstring.data; )*>
```

### Description

The element `ce:italic` is a [font changing element](#) (p. 155). It is used to obtain italic.

### Usage

*XML*

```
<ce:italic>This text is in italic</ce:italic>
```

*Presentation*

*This text is in italic*

Formulae should be captured in MathML. This is not enforced for very simple formulae — these can be structured with text effect elements.

*XML*

```
<mml:math>
  <mml:mrow>
    <mml:mi>p</mml:mi>
    <mml:mo>+</mml:mo>
    <mml:mi>q</mml:mi>
    <mml:mo>=</mml:mo>
    <mml:mi>r</mml:mi>
  </mml:mrow>
</mml:math>
```

*Presentation*

$p + q = r$

### Version history

Prior to DTD 5.0, this element was called `it`.

### See also

For more information see the section on [text effects](#) (p. 155). See also [ce:bold](#), [ce:cross-out](#), [ce:monospace](#), [ce:sans-serif](#), [ce:small-caps](#), [ce:underline](#).

## ce:keyword

### Declaration

#### Model (CEPs 1.1.0–1.1.6)

```
<!ELEMENT ce:keyword ( ce:text, ce:keyword* )>
```

### Description

The element [ce:keyword](#) is used to capture a keyword or classification code.

### Usage

See [ce:keywords](#).

### Version history

Prior to DTD 5.0, this element was called `kwd`.



## ce:keywords

### Declaration

#### Model (CEPs 1.1.0–1.1.4)

```
<!ELEMENT ce:keywords ( ce:section-title?, ce:keyword+ )>
<!ATTLIST ce:keywords
  class CDATA "keyword"
  xml:lang %language; #IMPLIED>
```

#### Model (CEP 1.1.5)

```
<!ELEMENT ce:keywords ( ce:section-title?, ce:keyword+ )>
<!ATTLIST ce:keywords
  class CDATA "keyword"
  xml:lang %iso639; #IMPLIED>
```

#### Model (CEP 1.1.6)

```
<!ELEMENT ce:keywords ( ce:section-title?, ce:keyword+ )>
<!ATTLIST ce:keywords
  view %view; 'all'
  class CDATA "keyword"
  xml:lang %iso639; #IMPLIED>
```

### Description

Sets of keywords form a keyword group, `ce:keywords`, which may occur in various classes in an article.

### Usage

A keyword group consists of a sequence of keywords or classification codes, `ce:keyword`. Keywords can be nested one level deep.

The element `ce:keywords` has two attributes. The language of the keywords (if applicable), if different from the language of the article, should be specified in the `xml:lang` attribute. See Section 7.5 (p. 162) for an overview of the allowed language codes.

The type of keywords or classification scheme is given by the attribute `class`. This attribute is of type CDATA so that additional values can be added without a DTD update. The only values allowed for `class` are described below.

- `keyword` is the default. It is used for ordinary keywords. Second-order keywords can be captured using a nested keyword.

XML

```
<ce:keywords>
  <ce:section-title>Keywords</ce:section-title>
  <ce:keyword><ce:text>Electroplating</ce:text></ce:keyword>
  <ce:keyword><ce:text>Electrodeposited
    photoresist</ce:text></ce:keyword>
  <ce:keyword><ce:text>3D fabrication</ce:text></ce:keyword>
</ce:keywords>
```

*Presentation*

*Keywords:* Electroplating; Electrodeposited photoresist; 3D fabrication

- abr is used for abbreviations in an abbreviation list. Similar to `ce:nomenclature`, these are the abbreviations used in a document. They are printed at the bottom of the first page of the article like a footnote.

*XML*

```
<ce:keywords class="abr">
  <ce:section-title>Abbreviations</ce:section-title>
  <ce:keyword>
    <ce:text>mtDNA</ce:text><ce:keyword><ce:text>mitochondrial
      DNA</ce:text></ce:keyword>
  </ce:keyword>
  <ce:keyword><ce:text>WT</ce:text><ce:keyword>
    <ce:text>wildtype</ce:text></ce:keyword>
  </ce:keyword>
  <ce:keyword><ce:text>GFP</ce:text><ce:keyword><ce:text>green
    fluorescent protein</ce:text></ce:keyword>
  </ce:keyword>
</ce:keywords>
```

*Presentation*

*Abbreviations:* mtDNA, mitochondrial DNA; WT, wildtype; GFP, green fluorescent protein.

- jel is a subject classification used in Economics, based on the classification used by the *Journal of Economics Literature* ([www.aeaweb.org](http://www.aeaweb.org)). These keywords may not be nested.

*XML*

```
<ce:keywords class="jel">
  <ce:section-title>JEL classification</ce:section-title>
  <ce:keyword><ce:text>C1</ce:text></ce:keyword>
  <ce:keyword><ce:text>D11</ce:text></ce:keyword>
</ce:keywords>
```

*Presentation*

*JEL classification:* C1; D11

- msc is used for the MSC classification, which evolved from the American Mathematical Society’s subject classification (see [www.ams.org/msc](http://www.ams.org/msc)). A document can have “primary” classifications and additional “secondary” classifications.

*XML*

```
<ce:keywords class="msc">
  <ce:section-title>MSC</ce:section-title>
  <ce:keyword>
    <ce:text>primary</ce:text>
    <ce:keyword><ce:text>60K37</ce:text></ce:keyword>
  </ce:keyword>
  <ce:keyword>
    <ce:text>secondary</ce:text>
    <ce:keyword><ce:text>60F17</ce:text></ce:keyword>
    <ce:keyword><ce:text>82D30</ce:text></ce:keyword>
  </ce:keyword>
</ce:keywords>
```

*Presentation*

MSC: primary 60K37; secondary 60F17; 82D30

*XML*

```
<ce:keywords class="msc">
  <ce:section-title>MSC</ce:section-title>
  <ce:keyword><ce:text>60G50</ce:text></ce:keyword>
  <ce:keyword><ce:text>60K35</ce:text></ce:keyword>
</ce:keywords>
```

*Presentation*

MSC: 60G50; 60K35

*XML*

```
<ce:keywords class="msc">
  <ce:section-title>MSC</ce:section-title>
  <ce:keyword>
    <ce:text>primary</ce:text>
  </ce:keyword>
  <ce:keyword><ce:text>62G20</ce:text></ce:keyword>
  <ce:keyword><ce:text>62G30</ce:text></ce:keyword>
  <ce:keyword><ce:text>62M05</ce:text></ce:keyword>
</ce:keyword>
</ce:keywords>
```

*Presentation*

MSC: primary 62G20; 62G30; 62M05

- pacs is used for the PACS classification scheme ([www.aip.org/pacs](http://www.aip.org/pacs)). Keywords in this class may not be nested.

*XML*

```
<ce:keywords class="pacs">
  <ce:section-title>PACS</ce:section-title>
  <ce:keyword><ce:text>85.25.Cp</ce:text></ce:keyword>
  <ce:keyword><ce:text>74.50.+r</ce:text></ce:keyword>
  <ce:keyword><ce:text>75.80</ce:text></ce:keyword>
</ce:keywords>
```

*Presentation*

PACS: 85.25.Cp; 74.50.+r; 75.80

- mat is used for entries in a “Materials” index. These keywords may not be nested and are not necessarily presented in a rendering application.
- src is used for entries in a “Sources” index. These keywords may not be nested and are not necessarily presented in a rendering application.
- idt (index terms) is used for entries in a subject index. These keywords may not be nested and are not presented in a rendering of the item itself. By combining the idt keywords of various items, e.g., the items in a particular issue, a subject index is created.
- psycinfo is used for PsycINFO classifications ([www.apa.org/psycinfo](http://www.apa.org/psycinfo)). These keywords may not be nested.

*XML*

```
<ce:keywords class="psycinfo">
  <ce:section-title>PsycINFO classification</ce:section-title>
  <ce:keyword><ce:text>2360</ce:text></ce:keyword>
  <ce:keyword><ce:text>3313</ce:text></ce:keyword>
</ce:keywords>
```

*Presentation*

PsycINFO classification: 2360; 3313

- neurosci is used to assign “themes” and “topics” (evolved from the Society of Neuroscience, [www.elsevier.nl/locate/bres](http://www.elsevier.nl/locate/bres)). Topics (such as “Blood–brain barrier”) are second-order keywords belonging to the theme (“Cellular and Molecular Biology”).

*XML*

```
<ce:keywords class="neurosci">
  <ce:keyword>
    <ce:text>Cellular and Molecular Biology</ce:text>
  </ce:keyword>
  <ce:keyword>
    <ce:text>Blood&ndash;brain barrier</ce:text>
  </ce:keyword>
</ce:keywords>
```

*Presentation*

*Theme:* Cellular and Molecular Biology

*Topic:* Blood–brain barrier

- inspec-cc is used for INSPEC classification codes ([www.iee.org.uk](http://www.iee.org.uk)). Keywords in this class may not be nested.

*XML*

```
<ce:keywords class="inspec-cc">
  <ce:section-title>Classification codes</ce:section-title>
  <ce:keyword><ce:text>A0470</ce:text></ce:keyword>
  <ce:keyword><ce:text>A9760L</ce:text></ce:keyword>
</ce:keywords>
```

*Presentation*

*Classification codes:* A0470; A9760L

- inspec-ct is used for INSPEC classification terms ([www.iee.org.uk](http://www.iee.org.uk)). Keywords in this class may not be nested.

*XML*

```
<ce:keywords class="inspec-ct">
  <ce:section-title>Thesaurus terms</ce:section-title>
  <ce:keyword><ce:text>accelerator-based
  transmutation</ce:text></ce:keyword>
  <ce:keyword><ce:text>haptic interfaces</ce:text></ce:keyword>
</ce:keywords>
```

*Presentation*

*Thesaurus terms:* accelerator-based transmutation; haptic interfaces

- inspec-chi is used for INSPEC chemical index terms. Keywords in this class may not be nested.

*XML*

```
<ce:keywords class="inspec-chi">
  <ce:section-title>Chemical index</ce:section-title>
  <ce:keyword><ce:text>LaMnO3/ss</ce:text></ce:keyword>
  <ce:keyword><ce:text>La/ss</ce:text></ce:keyword>
  <ce:keyword><ce:text>Mn/ss</ce:text></ce:keyword>
  <ce:keyword><ce:text>O3/ss</ce:text></ce:keyword>
  <ce:keyword><ce:text>O/ss</ce:text></ce:keyword>
</ce:keywords>
```

*Presentation*

*Chemical index:* LaMnO3/ss; La/ss; Mn/ss; O3/ss; O/ss

- stma is used for STMA (Statistical Theory & Methods Abstracts, [www.cbs.nl/isi](http://www.cbs.nl/isi)) classification codes. These keywords may not be nested.

XML

```
<ce:keywords class="stma">
  <ce:section-title>Statistical Theory
    and Method Abstracts</ce:section-title>
  <ce:keyword><ce:text>00:050</ce:text></ce:keyword>
  <ce:keyword><ce:text>06:900</ce:text></ce:keyword>
</ce:keywords>
```

Presentation

*Statistical Theory and Method Abstracts: 00:050; 06:900*

- astronomy is used for controlled astronomical keywords, taken from the astronomical thesaurus, used, e.g., in *New Astronomy*. This class replaces the default class keyword, which therefore may not be used.

XML

```
<ce:keywords class="astronomy">
  <ce:section-title>Keywords</ce:section-title>
  <ce:keyword>
    <ce:text>Cosmic microwave background</ce:text>
  </ce:keyword>
  <ce:keyword>
    <ce:text>Cosmology: theory</ce:text>
  </ce:keyword>
</ce:keywords>
```

Presentation

*Keywords: Cosmic microwave background; Cosmology: theory*

- geo is used for controlled keywords from the geo thesaurus as used in *EPSL Online*. This class replaces the default class keyword, which therefore may not be used.

XML

```
<ce:keywords class="geo">
  <ce:section-title>Keywords</ce:section-title>
  <ce:keyword>
    <ce:text>fission-track dating</ce:text>
  </ce:keyword>
  <ce:keyword>
    <ce:text>uranium disequilibrium</ce:text>
  </ce:keyword>
</ce:keywords>
```

Presentation

*Keywords: fission-track dating; uranium disequilibrium*

- cras is used for the subject classification used in the journals of the *Comptes Rendues de l'Académie des Sciences* collection. Each consists of a keyword, or a keyword and a subkeyword.

XML

```
<ce:keywords class="cras-terre">
  <ce:keyword>
    <ce:text>Géochimie</ce:text>
  <ce:keyword>
    <ce:text>Géosciences de surface</ce:text>
  </ce:keyword>
</ce:keywords>
```

```

    </ce:keyword>
  </ce:keywords>
  <ce:keywords class="cras-terre" xml:lang="en">
    <ce:keyword>
      <ce:text>Geochemistry</ce:text>
      <ce:keyword>
        <ce:text>Surface Geosciences</ce:text>
      </ce:keyword>
    </ce:keyword>
  </ce:keywords>

```

*Presentation*

**Géochimie / Géosciences de surface**  
**Geochemistry / Surface Geosciences**

- ctsnet is used for the CTSNet classifications (Cardiothoracic Surgery Network, [www.ctsnet.org](http://www.ctsnet.org)). These keywords may not be nested and are not necessarily presented in a rendering application.

*XML*

```

<ce:keywords class="ctsnet">
  <ce:section-title>CTSNet classification</ce:section-title>
  <ce:keyword><ce:text>22</ce:text></ce:keyword>
  <ce:keyword><ce:text>23</ce:text></ce:keyword>
</ce:keywords>

```

*Presentation*

*CTSNet classification: 22; 23*

- cell is to be used for a forthcoming classification scheme used in *Cell*.
- thelancet is to be used for a forthcoming classification scheme used in *The Lancet*.
- ranking is used for Year Books. It is not necessarily represented in a rendering representation.

*XML*

```

<ce:keywords class="ranking">
  <ce:section-title>Evidence Ranking</ce:section-title>
  <ce:keyword><ce:text>C</ce:text></ce:keyword>
</ce:keywords>

```

*Presentation*

*Evidence Ranking: C*

- rating is used for Year Books. It is not necessarily represented in a rendering representation.

*XML*

```

<ce:keywords class="rating">
  <ce:section-title>Expert Rating</ce:section-title>
  <ce:keyword><ce:text>1</ce:text></ce:keyword>
</ce:keywords>

```

*Presentation*

*Expert Rating: 1*

## Version history

Prior to DTD 5.0, this element was called kwdg. In CEP 1.1.1 the value it was added to parameter entity `%language;`. As of CEP 1.1.5, all languages contained in `%iso639;` are allowed. The `view` attribute was added in CEP 1.1.6.

## See also

[ce:keyword](#)

## ce:label

### Declaration

#### Model (CEPs 1.1.0–1.1.6)

```
<!ELEMENT ce:label ( %text.data; )*>
```

### Description

The designation (number, name, label) of various elements is contained in the `ce:label` element.

### Usage

The `ce:label` element is used to contain the designation of the parent element, e.g. “2.1.6”, “Fig. 2”, “Plate VII” or “Lemma 1.6”.

#### XML

```
<ce:affiliation id="aff2"><ce:label>b</ce:label> ...
<ce:footnote id="fn4"><ce:label>4</ce:label> ...
<ce:section id="sec2"><ce:label>2</ce:label> ...
<ce:section id="sec3.1"><ce:label>3.1</ce:label> ...
<ce:enunciation id="lem1.6"><ce:label>Lemma 1.6</ce:label> ...
```

#### Presentation

<sup>b</sup> Affiliation...

<sup>4</sup> Footnote...

**2. Section...**

*3.1. Section...*

**Lemma 1.6...**

#### Explanation

Note that `ce:label` generates some presentation: the closing full stops and the superscript position of the footnote number are generated by the `ce:label`, whereas they would have to be inserted explicitly in a `ce:cross-ref`. This allows the application to build cross-reference destination lists directly from the content of `ce:label`.

For explanation of the precise usage of `ce:label`, refer to the parents.

The element `ce:label` plays an important role in cross-referencing, especially for one-to-many links.

### Version history

Prior to DTD 5.0, this element was called `no`.

### See also

For more information, see the parent elements, the section [Cross-references and the label element](#) (p. 151), `ce:cross-ref`.



## ce:last-page

### Declaration

#### Model (CEPs 1.1.0–1.1.6)

```
<!ELEMENT ce:last-page ( %richstring.data; )*>
```

### Description

The last page of an item called by a hub file is captured using [ce:last-page](#).

### Usage

See [ce:pages](#).

### Version history

This element was added in CEP 1.1.0.

### See also

[ce:include-item](#), [ce:first-page](#)

## ce:legend

### Declaration

#### Model (CEPs 1.1.0–1.1.6)

```
<!ELEMENT ce:legend ( ce:simple-para+ )>
```

### Description

A [ce:legend](#) contains explanatory text belonging to a table.

### Usage

A legend appears at the bottom of a table. It contains one or more simple paragraphs, [ce:simple-para](#). It is an extension to the CALS table model.

For more information about tables, see [ce:table](#).

### See also

[ce:table-footnote](#)

## ce:link

### Declaration

#### Model (CEPs 1.1.0–1.1.6)

<!ELEMENT	ce:link	EMPTY>		
<!ATTLIST	ce:link			
	id	ID		#IMPLIED
	locator	ENTITY		#REQUIRED>

### Description

For the purpose of referring to external files, the general element `ce:link` is provided.

### Usage

The element `ce:link` instructs the rendering application to pull in an external file, e.g. an artwork file or an audio file. What needs to be done with the external file depends on the parent element. Such external files belonging to the XML file are called *assets*.

`ce:link` has one mandatory attribute `locator` which is an entity declared in the document's declaration subset as an external file. From that entity declaration, the application retrieves the type of the external file: APPLICATION, AUDIO, IMAGE, TEXT, VIDEO or XML.

The *name* of the entity is irrelevant; the name of the file, however, is.

```
XML
<!ENTITY loc3 SYSTEM "fx22" NDATA IMAGE>
...
<ce:inline-figure><ce:link locator="loc3"/></ce:inline-figure>
...
```

In this example, `ce:link` tells the rendering application which external file must be used to render the inline figure. This is done through the entity `loc3` which is an image file with file name (without extension) `fx22`. A separate catalog file redirects the rendering application to the correct file, e.g. `fx22.tif`.

### Version history

As from CEP 1.1.2 the attribute list no longer contains file-size information.

### See also

[Entities and the DOCTYPE declaration](#) (p. 14).

## ce:list

### Declaration

#### Model (CEPs 1.1.0–1.1.5)

```
<!ELEMENT ce:list ( ce:label?, ce:section-title?,
                    ce:list-item+ )>
<!ATTLIST ce:list
          id ID #IMPLIED>
```

#### Model (CEP 1.1.6)

```
<!ELEMENT ce:list ( ce:label?, ce:section-title?,
                    ce:list-item+ )>
<!ATTLIST ce:list
          id ID #IMPLIED
          role CDATA #IMPLIED>
```

### Description

The element `ce:list` is used to capture free-format lists.

### Usage

The element `ce:list` provides a way to capture lists, where the labels are left entirely to the user.

A `ce:list` has an optional number or label (`ce:label`) and an optional section title (`ce:section-title`). It has an optional `id` attribute so that it can become the target of a cross-reference.

A list consists of one or more list items, `ce:list-item`. Each list item can have a `ce:label`, containing the list item’s label, and consists of one or more paragraphs, `ce:para`. If the `ce:label` element is absent, then the item is indented, and the result is a “tab list”.

A `ce:list-item` can have an `id` so that it can become the target of a cross-reference.

*XML*

```
<ce:list>
  <ce:list-item>
    <ce:label>(iii)</ce:label>
    <ce:para>Item 3...</ce:para>
  </ce:list-item>
  <ce:list-item>
    <ce:label>(iv)</ce:label>
    <ce:para>Item 4...</ce:para>
  </ce:list-item>
</ce:list>
```

*XML*

```
<ce:list>
  <ce:list-item>
    <ce:label>&rttrif;</ce:label>
    <ce:para>Item ...</ce:para>
  </ce:list-item>
  <ce:list-item>
```

```
<ce:label>&rtrif;</ce:label>  
<ce:para>Item ...</ce:para>  
</ce:list-item>  
</ce:list>
```

## Version history

Prior to DTD 5.0, lists with auto-generated labels could be obtained with the `l` element. The `role` attribute was added in CEP 1.1.6.

## See also

[ce:def-list](#)

## ce:list-item

### Declaration

#### Model (CEPs 1.1.0–1.1.6)

```
<!ELEMENT ce:list-item ( ce:label?, ce:para+ )>
<!ATTLIST ce:list-item
  id ID #IMPLIED>
```

### Description

The element `ce:list-item` is used to capture list items within `ce:list`.

### Usage

See `ce:list`.

## ce:marker

### Declaration

#### Model (CEPs 1.1.0.1–1.1.6)

<!ELEMENT	ce:marker	EMPTY	>
<!ATTLIST	ce:marker		
	name	CDATA	#REQUIRED
	alt	CDATA	#REQUIRED
	altimg	CDATA	#REQUIRED
	altimg-small	CDATA	#REQUIRED

### Description

A marker is a small icon which marks a special property of an article. Examples are: ‘Fast track article’, ‘Continuous Medical Education (CME) article’. The marker is usually shown in the Table of Contents of an issue, before or after the title, and on the first page of an article.

### Usage

The marker icons are pixel perfect gif files, similarly to all other altimages.

The [name](#) attribute contains a name for the marker, which allows one to categorize articles with such markers. Applications should ignore marker names unknown to them.

The [alt](#) attribute contains an alternative text for the marker icon. The text should be a short indication of the category of articles marked by this marker.

The [altimg](#) attribute contains the name of the marker icon.

The [altimg-small](#) attribute contains the name of a smaller-sized version of the marker icon. This version should be used when the marker is printed inline, especially with the article title in the Table of Contents.

#### XML

```
<ce:markers>
  <ce:marker name="cme"
    alt="Continuous Medical Education"
    altimg-small="cme_small.gif" altimg="cme.gif"/>
  <ce:marker name="swift"
    alt="Fast Track Article"
    altimg-small="swift_small.gif" altimg="swift.gif"/>
</ce:markers>
```

#### Explanation

This article has two markers, one indicating that it contains Continuous Medical Education material, the other indicating that it is a fast-track article. The [alt](#) texts show these meanings as a tool-tip if the icons are not displayed. The icons are delivered in two sizes, called small and large. There is no indication of the actual sizes.

The normal-sized icon is to be shown on the first page of the article. The small icon is to be used inline in the Table of Contents.

**Light reading**

A marker should not be used for article features which can be derived from the article's content, such as the presence of e-extra material. If web platforms wish to show a marker for such features, they should generate it based on programmatic inspection of the article.

**Version history**

This element was added in CEPs 1.1.0.1 and 1.1.4.



## ce:markers

### Declaration

#### Model (CEPs 1.1.0.1–1.1.6)

```
<!ELEMENT ce:markers ( ce:marker+ )>
```

### Description

An article may contain multiple [ce:marker](#) elements. These are contained in the element [ce:markers](#).

### Usage

See [ce:marker](#).

### Version history

This element was added in CEPs 1.1.0.1 and 1.1.4.

### See also

[ce:marker](#)

## ce:miscellaneous

### Declaration

#### Model (CEPs 1.1.0–1.1.5)

```
<!ELEMENT ce:miscellaneous ( %text.data; )*>
```

#### Model (CEP 1.1.6)

```
<!ELEMENT ce:miscellaneous ( %text.data; )*>
<!ATTLIST ce:miscellaneous
  role          CDATA          #IMPLIED>
```

### Description

The `ce:miscellaneous` element is used to capture miscellaneous history information of the article. It is an optional element within the frontmatter.

### Usage

Miscellaneous history information is contained in `ce:miscellaneous`. The most common information captured using this element is the communicating editor. In principle, each journal can have its own convention.

*XML*

```
<ce:miscellaneous>Communicated by M. Nivat</ce:miscellaneous>
```

*Presentation*

```
Communicated by M. Nivat
```

### Rendering notes

`ce:miscellaneous` does not generate any text.

### Version history

Prior to DTD 5.0, this element was called `misc`. The `role` attribute was added in CEP 1.1.6.

## ce:monospace

### Declaration

#### Model (CEPs 1.1.0–1.1.6)

```
<!ELEMENT ce:monospace ( %richstring.data; )*>
```

### Description

The element [ce:monospace](#) is a [font changing element](#) (p. 155). It is used to obtain a monospaced typewriter font.

### Usage

To obtain a monospaced “typewriter” font, the element [ce:monospace](#) is used.

#### XML

```
<ce:monospace>&lt;ce:monospace&gt;Monospace  
font&lt;/ce:monospace&gt;</ce:monospace>
```

#### Presentation

```
<ce:monospace>Monospace font</ce:monospace>
```

In combination with text tables or tab lists [ce:monospace](#) is popular for capturing computer code fragments; this is also known as verbatim text. To obtain multiple spaces use sequences of nonbreakable spaces [&#x00A0;](#).

### Version history

Prior to DTD 5.0, this element was called `ty`.

### See also

For more information see the section on [text effects](#) (p. 155). See also [ce:bold](#), [ce:cross-out](#), [ce:italic](#), [ce:sans-serif](#), [ce:small-caps](#), [ce:underline](#).

## ce:nomenclature

### Declaration

#### Model (CEPs 1.1.0–1.1.5)

```
<!ELEMENT ce:nomenclature ( ce:section-title?, ce:def-list+ )>
```

#### Model (CEP 1.1.6)

```
<!ELEMENT ce:nomenclature ( ce:section-title?, ce:def-list+ )>
```

```
<!ATTLIST ce:nomenclature
```

id	ID	#IMPLIED
role	CDATA	#IMPLIED
view	%view;	'all'

### Description

Nomenclature, a listing of the terms used in a document, is captured with `ce:nomenclature`.

### Usage

Nomenclature contains one or more listings of terms and definitions used in the document. Each such listing is a `ce:def-list` within `ce:nomenclature`.

The title of the nomenclature, mostly “Nomenclature”, is captured with the optional subelement `ce:section-title`.

#### XML

```
<ce:nomenclature>
  <ce:section-title>Nomenclature</ce:section-title>
  <ce:def-list>
    <ce:def-term>
      <ce:italic>A<ce:inf>n</ce:inf></ce:italic>
    </ce:def-term>
    <ce:def-description>
      <ce:para>area of nozzle, m<ce:sup>2</ce:sup></ce:para>
    </ce:def-description>
    <ce:def-term>
      <ce:italic>C<ce:inf>A</ce:inf></ce:italic>
    </ce:def-term>
    <ce:def-description>
      <ce:para>concentration of CO<ce:inf>2</ce:inf> in solution,
        mol/m<ce:sup>3</ce:sup></ce:para>
    </ce:def-description>
    <ce:def-term>
      <ce:italic>C<ce:inf>AG</ce:inf></ce:italic>
    </ce:def-term>
    <ce:def-description>
      <ce:para>concentration of CO<ce:inf>2</ce:inf> in gas
        phase, mol/m<ce:sup>3</ce:sup></ce:para>
    </ce:def-description>
  </ce:def-list>
</ce:nomenclature>
```

```

        <ce:italic>v<ce:sup>*</ce:sup></ce:italic>
    </ce:def-term>
    <ce:def-description>
        <ce:para>friction velocity, m/s</ce:para>
    </ce:def-description>
</ce:def-list>
<ce:def-list>
    <ce:section-title>Greek letters</ce:section-title>
    <ce:def-term>Φ</ce:def-term>
    <ce:def-description>
        <ce:para>empirical constant</ce:para>
    </ce:def-description>
</ce:def-list>
</ce:nomenclature>

```

*Presentation*

Nomenclature			
$A_n$	area of nozzle, m <sup>2</sup>	$v^*$	friction velocity, m/s
$C_A$	concentration of CO <sub>2</sub> in solution, mol/m <sup>3</sup>	<i>Greek letters</i>	
$C_{AG}$	concentration of CO <sub>2</sub> in gas phase, mol/m <sup>3</sup>	Φ	empirical constant

## Version history

The [id](#), [role](#) and [view](#) attributes were added in CEP 1.1.6.

## See also

Similar constructs to capture this information are [ce:keywords](#) with [class](#) equal to [abr](#) and [ce:glossary](#).

## ce:note

### Declaration

#### Model (CEPs 1.1.0–1.1.6)

```
<!ELEMENT ce:note ( ce:simple-para+ )>
```

### Description

Within structured bibliographic references, `ce:note` contains descriptive paragraphs about the reference. It can also contain an endnote.

### Usage

A `ce:note` contains one or more paragraphs, `ce:simple-para`. In a structured reference, it can occur on its own or after a bibliographic reference. On its own, it is effectively an “endnote”, which may coexist beside footnotes and are listed between bibliographic references. After a bibliographic reference, it contains descriptive text about the reference, not to be confused with an `sb:comment`.

#### XML

```
<ce:bib-reference id="bib49">
  <ce:label>[49]</ce:label>
  <sb:reference>
    <sb:comment>See the references in</sb:comment>
    <sb:contribution>...</sb:contribution>
    <sb:comment>first published in</sb:comment>
    <sb:host>...</sb:host>
    <sb:comment>also available electronically as</sb:comment>
    <sb:host>...</sb:host>
    <sb:comment>(in Japanese)</sb:comment>
  </sb:reference>
  <ce:note>
    <ce:simple-para>This reference explains the usage of the comment
      and note elements. Comments and the other components of the
      sb:reference together form one text. The note may contain
      details about the reference.</ce:simple-para>
  </ce:note>
</ce:bib-reference>
<ce:bib-reference id="bib50">
  <ce:label>[50]</ce:label>
  <ce:note>
    <ce:simple-para>This is a note in between the references,
      an endnote.</ce:simple-para>
  </ce:note>
</ce:bib-reference>
```

#### Presentation

[49] See the references in ... first published in ... also available electronically as ... (in Japanese).

This reference explains the usage of the comment and note elements. Comments and the other components of the `sb:reference` together form one text. The note may contain details about the reference.

[50] This is a note in between the references, an endnote.

### **See also**

Structured references are explained in more detail in the section [Bibliographic references](#) (p. 394).

## ce:note-para

### Declaration

#### Model (CEPs 1.1.0–1.1.4)

```
<!ELEMENT ce:note-para ( %note.data; )*>
<!ATTLIST ce:note-para
  id ID #IMPLIED>
```

#### Model (CEP 1.1.5)

```
<!ELEMENT ce:note-para ( %note.data; )*>
<!ATTLIST ce:note-para
  id ID #IMPLIED>
```

#### Model (CEP 1.1.6)

```
<!ELEMENT ce:note-para ( %note.data; )*>
<!ATTLIST ce:note-para
  id ID #IMPLIED
  role CDATA #IMPLIED
  view %view; 'all'>
```

### Description

Paragraphs of text within footnotes and notes, are captured using the element [ce:note-para](#).

### Usage

A note paragraph, [ce:note-para](#), belongs to the lowest-level structuring elements. It contains text and objects structured with the elements in [%note.data](#), and differs from a full paragraph, [ce:para](#), in that footnotes and floating objects are not allowed.

### Version history

The [role](#) and [view](#) attributes were added in CEP 1.1.6.

### See also

[ce:para](#), [ce:simple-para](#).



## ce:other-ref

### Declaration

#### Model (CEPs 1.1.0–1.1.6)

```
<!ELEMENT ce:other-ref ( ce:label?, ce:textref )>
<!ATTLIST ce:other-ref
            id ID #IMPLIED>
```

### Description

The element `ce:other-ref` is used to capture bibliographic references that cannot be structured.

### Usage

If structuring a bibliographic reference in an `sb:reference` is not possible, then `ce:other-ref` can be used. Known examples are maps and patents, but also incomplete references can be tagged this way. However, the content of `ce:other-ref` must be a bibliographic reference; to create reference lists that also contain endnotes the element `ce:note` can be used.

A bibliographic reference, when tagged using `ce:other-ref`, needs to be marked up according to the journal style, e.g., if a title should be italics, it should explicitly be marked up.

The element `ce:other-ref` has an optional `ce:label` subelement and an `id` attribute. These are used when the `ce:other-ref` is part of a multiple reference.

### Copy edit considerations

As noted above, a bibliographic reference tagged with `ce:other-ref` can still contain tagged information. In particular URLs can be tagged (with `ce:inter-ref`).

*XML*

```
<ce:bib-reference id="bib15">
  <ce:label>[15]</ce:label>
  <ce:other-ref>
    <ce:textref>S. Barrett, QuackWatch, Allentown, PA, USA,
      <ce:inter-ref xlink:href="http://www.quackwatch.org/">
        http://www.quackwatch.org/</ce:inter-ref>
        [accessed March 2003].</ce:textref>
  </ce:other-ref>
</ce:bib-reference>
```

### See also

Structured references are explained in more detail in the section [Bibliographic references](#) (p. 394).

## ce:pages

### Declaration

#### Model (CEPs 1.1.0–1.1.6)

```
<!ELEMENT ce:pages ( ce:first-page, ce:last-page? )>
```

### Description

The pages of an item called by a hub file are captured using [ce:pages](#).

### Usage

The element [ce:pages](#) contains a mandatory [ce:first-page](#) and an optional [ce:last-page](#).

*XML*

```
<ce:pages>
  <ce:first-page>37</ce:first-page>
  <ce:last-page>51</ce:last-page>
</ce:pages>
```

*XML*

```
<ce:pages>
  <ce:first-page>L1</ce:first-page>
  <ce:last-page>L13</ce:last-page>
</ce:pages>
```

*XML*

```
<ce:pages>
  <ce:first-page>iv</ce:first-page>
</ce:pages>
```

The element [ce:last-page](#) is not used when the page range spans a single page.

If the document style is to render a page range as 127–9, then the element [ce:last-page](#) must contain 129.

### Version history

This element was added in CEP 1.1.0.

### See also

[ce:include-item](#)

## ce:para

### Declaration

#### Model (CEPs 1.1.0–1.1.4)

```
<!ELEMENT ce:para ( %par.data; )*>
<!ATTLIST ce:para
  id ID #IMPLIED
  role CDATA #IMPLIED
  view %view; 'all'>
```

#### Model (CEPs 1.1.5, 1.1.6)

```
<!ELEMENT ce:para ( %par.data; )*>
<!ATTLIST ce:para
  id ID #IMPLIED
  role CDATA #IMPLIED
  view %view; 'all'>
```

### Description

Paragraphs of text are captured using the element `ce:para`.

### Usage

A paragraph, `ce:para`, belongs to the lowest-level structuring elements. It contains text and objects structured with the elements in `%par.data;`.

The attribute `id` can be used to cross-reference to the paragraph.

The attribute `role` allows one to categorize paragraphs, and attach a special meaning to them. For instance, it makes it possible to mark a paragraph as a “motto”, and handle it in a different way than an ordinary paragraph. Applications should treat roles unknown to them as ordinary paragraphs. The role must belong to a list validated by the XML validation tools. At the time of writing, the following roles exist.

- `motto` is used to turn a paragraph into a motto.

*XML*

```
<ce:para role="motto">Everything has a version number</ce:para>
```

- `exam-questions` is used to identify the paragraph which contains the actual exam questions. It should only be used for a paragraph in the element `ce:exam-questions`.
- `introduction` is used to mark the introductory paragraphs of an article. Introductory paragraphs are distinguished by some publications, which may print them, e.g., in boldface.
- `acknowledgement` is used to mark acknowledgement-like paragraphs, such as ‘Contributors’, ‘Conflicts of Interest’, etc.
- `question` is used to mark a paragraph with a single question and will enforce a special layout.

Items can appear in compact, standard and extended *views*. The attribute `view` is used to indicate in which views the paragraph must appear. Its default is to appear in all views. See also the section [Views](#) (p. 163).

### See also

[ce:note-para](#), [ce:simple-para](#)

## ce:pii

### Declaration

#### Model (CEPs 1.1.0–1.1.6)

```
<!ELEMENT ce:pii ( %string.data; )*>
```

### Description

The element `ce:pii` contains the PII of the item.

### Usage

Each item must have a PII, a *publisher item identifier*. To identify the document, `ce:pii` is populated with the PII of the document. The full PII with formatting characters (e.g. parentheses, hyphens) must be used. The different types of PII are described in [27].

For journal articles, an alternative means of identification is the combination of journal code, `jid`, and article number, `aid`.

### See also

`aid`, `ce:doi`, `jid`

## ce:preprint

### Declaration

#### Model (CEPs 1.1.0–1.1.6)

```
<!ELEMENT ce:preprint          ( ce:inter-ref )>
```

### Description

The element `ce:preprint` is used to create a link between a document and an associated preprint version.

### Usage

Many articles have an associated preprint version, which is stored in a preprint archive. In order to create a link between the article and its associated preprint version, the element `ce:preprint` is provided. It contains one subelement, `ce:inter-ref`, which is the actual link. The content of `ce:inter-ref` is empty in this context.

Only preprints in a pre-defined list of repositories may be referenced, so that correct links can be created. Therefore, only a limited number of values for the scheme in `xlink:href` are allowed. Presently only `arxiv` is used.

#### XML

```
<ce:preprint>
  <ce:inter-ref id="interref8"
    xlink:role="http://www.elsevier.com/xml/linking-roles/preprint"
    xlink:href="arxiv:/hep-th/9112009"></ce:inter-ref>
</ce:preprint>
```

#### Explanation

This generates a link between the article and the associated preprint within the Los Alamos archive, whose URL is <http://www.arxiv.org/abs/hep-th/9112009>.

### Rendering notes

The element `ce:preprint` generates no output on paper, but in other media, a link with the preprint database may be created.

### See also

[ce:inter-ref](#)

## ce:presented

### Declaration

#### Model (CEPs 1.1.0–1.1.6)

```
<!ELEMENT ce:presented ( %textfn.data; )*>
```

### Description

In the head of an item, it is sometimes stated that the article was presented at a certain conference or by a certain person (mostly one of the authors). The `ce:presented` is provided for this purpose.

### Usage

The element `ce:presented` is an optional subelement of the head. It contains the complete statement identifying the presenter of the article and/or the place where the article was presented.

*XML*

```
<ce:presented>Presented by P. Walmsey</ce:presented>
```

### Version history

Prior to DTD 5.0, this element was called `prs`.

### Rendering notes

The text “Presented by” is not generated.

## ce:ranking

### Declaration

#### Model (CEPs 1.1.0–1.1.6)

```
<!ELEMENT ce:ranking ( %richstring.data; )*>
```

### Description

The element [ce:ranking](#) provides a way to mark “important” authors.

### Usage

In some scientific disciplines, especially Chemistry, it is common to mark the more important authors. Often, the same symbol is used as the one for corresponding author. If not, or if the particular author is not a corresponding author, [ce:ranking](#) can be used to capture the symbol. Conversely, it is not required to mark an author using [ce:ranking](#) if the importance is already signalled in other means. Indeed, it is possible that two authors are “important” but one has [ce:ranking](#) and the other has a corresponding author footnote ([ce:correspondence](#)).

#### XML

```
<ce:author id="au1">
  <ce:given-name>Jitendra</ce:given-name>
  <ce:surname>Sharma</ce:surname>
  <ce:ranking>*</ce:ranking>
</ce:author>
<ce:author id="au2">
  <ce:given-name>A.</ce:given-name>
  <ce:surname>Angelucci</ce:surname>
  <ce:ranking>*</ce:ranking>
</ce:author>
```

#### Presentation

Jitendra Sharma\*, A. Angelucci\*

### See also

[ce:author](#), [ce:correspondence](#)

## ce:reader-see

### Declaration

#### Model (CEPs 1.1.3–1.1.6)

```
<!ELEMENT ce:reader-see ( %text.data; )*>
```

### Description

The element `ce:reader-see` is used to capture general references.

### Usage

In indexes that are created by professional indexers, “see” or “see also” entries can appear that do not explicitly point to terms in the index, but instead require the reader’s expertise. In the first example below, taken from the *Encyclopedia of Food Sciences and Nutrition* (Academic Press, San Diego, 2003), the indexer has added an entry “absorption of nutrients” with reference “see *specific nutrients*”. A human reader can interpret this link, but it is not possible or viable to create a link in the XML file. With the element `ce:reader-see` such references without a link can be captured.

Unlike the elements `ce:see` and `ce:see-also`, no text is generated by `ce:reader-see`.

*XML*

```
<ce:index-entry>
  <ce:index-heading>absorption of nutrients</ce:index-heading>
  <ce:reader-see>see <ce:italic>specific
    nutrients</ce:italic></ce:reader-see>
</ce:index-entry>
```

*XML*

```
<ce:index-entry>
  <ce:index-heading>amines</ce:index-heading>
  ...
  <ce:index-entry>
    <ce:index-heading>biogenic</ce:index-heading>
    <ce:reader-see>see <ce:italic>individual
      amines</ce:italic></ce:reader-see>
  </ce:index-entry>
</ce:index-entry>
```

### Version history

This element was added in CEP 1.1.3.



## ce:refers-to-document

### Declaration

#### Model (CEPs 1.1.0–1.1.5)

```
<!ELEMENT ce:refers-to-document ( ce:doi | ( ce:pri, ce:doi? ) )>
```

#### Model (CEP 1.1.6)

```
<!ELEMENT ce:refers-to-document ( ce:doi | ( ce:pri, ce:doi? ) )>
<!ATTLIST ce:refers-to-document
          role                CDATA                #IMPLIED>
```

### Description

The element [ce:refers-to-document](#) is used to refer to another document.

### Usage

The element [ce:refers-to-document](#) consists of a [ce:pri](#) and/or a [ce:doi](#), alternative identifications of one and the same document, which must not be the document in which [ce:refers-to-document](#) itself occurs. If both PII and DOI are known, then both elements [ce:pri](#) and [ce:doi](#) will be present.

It is used to associate the two documents, e.g., to link an erratum with the article that it is an erratum to.

#### XML

```
<ce:refers-to-document>
  <ce:pri>S0031-9201(03)00274-7</ce:pri>
  <ce:doi>10.1016/j.pepi.2003.12.005</ce:doi>
</ce:refers-to-document>
```

#### Presentation

---

doi of original article: 10.1016/j.pepi.2003.12.005.

### Version history

This element was introduced in CEP 1.1.0 and replaced [ce:refers-to-article](#). The [role](#) attribute was added in CEP 1.1.6.

### See also

[ce:document-thread](#)

## ce:roles

### Declaration

#### Model (CEPs 1.1.0–1.1.6)

```
<!ELEMENT ce:roles ( %richstring.data; )*>
```

### Description

A sequence of named roles or job titles appearing after the author name is tagged with [ce:roles](#).

### Usage

Roles or job titles of the author may appear after an author name. These are captured using the [ce:roles](#) element. Roles or job titles are different from academic titles or degrees, which are part of [ce:degrees](#).

#### XML

```
<ce:roles>Chairman</ce:roles>
<ce:roles>Past Treasurer of the ACGIH</ce:roles>
<ce:roles>Editor-in-Chief</ce:roles>
<ce:roles>CEO, Reed&ndash;Elsevier</ce:roles>
```

### See also

[ce:author](#), [ce:degrees](#), [ce:suffix](#)

## ce:salutation

### Declaration

#### Model (CEPs 1.1.0–1.1.6)

```
<!ELEMENT ce:salutation ( %text.data; )*>
```

### Description

If an article begins with a salutation, this can be captured using `ce:salutation`.

### Usage

A salutation may appear at the beginning of the body of an article. It is tagged with `ce:salutation`.

#### XML

```
<body>
  <ce:salutation>Sir</ce:salutation>
  <ce:sections>
    <ce:section>
      <ce:para>David Brenner and Eric Hall make the assumption
        that our statement regarding ...</ce:para>
      ...
    </ce:section>
  </ce:sections>
</body>
```

#### Presentation

Sir—David Brenner and Eric Hall make the assumption that our statement regarding ...

### Rendering notes

Punctuation is generated. Note that the above presentation is a possible one. Instead of an em-dash a comma could be used, or the “Sir” could be typeset in small capitals.

## ce:sans-serif

### Declaration

#### Model (CEPs 1.1.0–1.1.6)

```
<!ELEMENT ce:sans-serif ( %richstring.data; )*>
```

### Description

The element `ce:sans-serif` is a [font changing element](#) (p. 155). It is used to obtain a sans-serif font.

### Usage

#### XML

```
Here is some <ce:sans-serif>sans-serif text</ce:sans-serif>
```

#### Presentation

Here is some sans-serif text

### Version history

Prior to DTD 5.0, this element was called `ssf`.

### See also

For more information see the section on [text effects](#) (p. 155). See also [ce:bold](#), [ce:cross-out](#), [ce:italic](#), [ce:monospace](#), [ce:small-caps](#), [ce:underline](#).

## ce:section

### Declaration

#### Model (CEPs 1.1.0–1.1.6)

```
<!ELEMENT ce:section          ( ( ( ce:section-title | ( ce:label,
                                ce:section-title? ) ), %parsec; ) |
                                ce:section+ )>
<!ATTLIST ce:section
  id          ID          #IMPLIED
  role       CDATA       #IMPLIED
  view       %view;      'all'>
```

### Description

The element `ce:section` is used to create sections and subsections.

### Usage

Sections and subsections are created using the element `ce:section`. Nested `ce:section` elements are used to create subsections. The nesting level determines the level of the section and hence the presentation of the section's number (`ce:label`) and title (`ce:section-title`).

A `ce:section` must have a `ce:label` and/or a `ce:section-title`, or it should be the parent of *only* `ce:sections`.

The optional section number is contained within `ce:label` without closing punctuation.

#### XML

```
<ce:section>
  <ce:label>2</ce:label>
  <ce:section-title>Asia</ce:section-title>
  <ce:section>
    <ce:label>2.1</ce:label>
    <ce:section-title>Japan</ce:section-title>
    <ce:para>...</ce:para>
  </ce:section>
  <ce:section>
    <ce:label>2.2</ce:label>
    <ce:section-title>Indonesia</ce:section-title>
    <ce:para>...</ce:para>
  </ce:section>
</ce:section>
```

#### Presentation

```
2. Asia
2.1. Japan
...
2.2. Indonesia
...
```

A section which contains *only* `ce:sections` is invisible in the rendering. Therefore it can be used to ‘jump’ or ‘skip’ section levels. There can be no text at the skipped level, not even after the contained sections.

*XML*

```

<ce:section id="s1">
  <ce:section-title>Level 1</ce:section-title>
  <ce:para>Some text at level 1</ce:para>
  <ce:section id="s1.1">
    <ce:section id="s1.1.1">
      <ce:section-title>Level 3</ce:section-title>
      <ce:para>Some text at level 3</ce:para>
      <ce:para>...</ce:para>
    </ce:section>
  </ce:section>
</ce:section>

```

*Presentation***Level 1***Level 3*

Some text at level 3

...

The attribute `id` is used to cross-reference to the section.

The attribute `role` allows one to categorize sections. For instance, it makes it possible to mark “Materials and Methods” sections, and handle these in different ways than ordinary sections. Applications should treat sections with roles unknown to them as ordinary sections, i.e., unknown roles must be ignored. The role must belong to a list validated by the XML validation tools. The following values for `role` have been defined:

- `case-report`. This role is used to identify a case report as is common in medical contexts.
- `materials-methods`. This role is used to identify a materials and methods section.
- `note-added-in-proof`. This role is used to identify a note added in proof section, which is added at proof stage and sometimes appears at the very end of the document.
- `results`. This role is used to identify a results section.
- `acknowledgement`. This role is used to mark acknowledgement-like sections, such as ‘Contributors’, ‘Conflicts of Interest’, etc.

*XML*

```

<ce:section id="sec3.5" role="materials-methods">
  <ce:label>3.5</ce:label>
  <ce:section-title>Materials and Methods</ce:section-title>
  ...
</ce:section>

```

*Explanation*

The section has become a “materials and methods” section. The presentation of such a section is style dependent; it is usually displayed in a somewhat smaller font size, but otherwise equal to an ordinary section.

Articles can appear in compact, standard and extended *views*. The attribute `view` is used to indicate in which views the section must appear. Its default is to appear in all views. See also the section [Views](#) (p. 163).

## **Version history**

Prior to DTD 5.0, this element was called `sec`.

## ce:sections

### Declaration

#### Model (CEPs 1.1.0–1.1.6)

```
<!ELEMENT ce:sections ( %parsec; )>
```

### Description

The element `ce:sections` is a container for sections and paragraphs (`%parsec;`).



## ce:section-title

### Declaration

#### Model (CEPs 1.1.0–1.1.6)

```
<!ELEMENT ce:section-title ( %nondisplay.data; )*>
<!ATTLIST ce:section-title
            id ID #IMPLIED>
```

### Description

The element `ce:section-title` is used to capture section titles.

### Usage

Element `ce:section-title` is used to capture the (section) title of the parent element.

The following elements can have `ce:section-title` as subelement: `ce:abstract`, `ce:abstract-sec`, `ce:acknowledgment`, `ce:bibliography`, `ce:bibliography-sec`, `ce:def-list`, `ce:enunciation`, `ce:exam-answers`, `ce:exam-questions`, `ce:further-reading`, `ce:further-reading-sec`, `ce:glossary`, `ce:glossary-sec`, `ce:index`, `ce:index-sec`, `ce:keywords`, `ce:list`, `ce:nomenclature`, `ce:section`, `objectives` in the EHS Books DTD, and `issue-sec` in the Serials Issue DTD.

### Version history

Prior to DTD 5.0, this element was called `st`.

## ce:see

### Declaration

#### Model (CEPs 1.1.0–1.1.6)

```
<!ELEMENT ce:see ( %text.data; )*>
<!ATTLIST ce:see
    refid IDREF #REQUIRED>
```

### Description

Within indexes, cross-references of the “see” type are captured with the `ce:see` element.

### Usage

In indexes one is often referred to another, preferred, term. This is common in subject indexes. It is done with the `ce:see` element which is a specialized version of the `ce:cross-ref` element. Note that the content of `ce:see` need not be the same as the content of the heading in the referred `ce:index-entry`.

#### XML

```
<ce:index-entry id="idx197">
  <ce:index-heading>Peyrone's salt</ce:index-heading>
  <ce:index-entry>
    <ce:index-heading>configuration</ce:index-heading>
    <ce:inter-ref id="interref246"
      xlink:href="pii:B008043076701001">17</ce:inter-ref>
  </ce:index-entry>
  <ce:index-entry>
    <ce:index-heading>history</ce:index-heading>
    <ce:inter-ref id="interref247"
      xlink:href="pii:B008043076701001">3</ce:inter-ref>
  </ce:index-entry>
</ce:index-entry>
...
<ce:index-entry id="idx258">
  <ce:index-heading>Platosemidiammine chloride</ce:index-heading>
  <ce:see refid="idx197">Peyrone's salt</ce:see>
</ce:index-entry>
```

#### Presentation

```
Peyrone's salt
  configuration, 17
  history, 3
...
Platosemidiammine chloride — see Peyrone's salt
```

### See also

[ce:see-also](#)

## ce:see-also

### Declaration

#### Model (CEPs 1.1.0–1.1.6)

```
<!ELEMENT ce:see-also ( %text.data; )*>
<!ATTLIST ce:see-also
  refid IDREF #REQUIRED>
```

### Description

Within indexes, cross-references of the “see also” type are captured with the `ce:see-also` element.

### Usage

In indexes one is often referred to another, related, term. This is common in subject indexes. It is done with the `ce:see-also` element which is a specialized version of the `ce:cross-ref` element. Note that the content of `ce:see-also` need not be the same as the content of the heading in the referred `ce:index-entry`.

#### XML

```
<ce:index-entry id="idx14">
  <ce:index-heading>axiomatizability</ce:index-heading>
  <ce:inter-ref id="interref19"
    xlink:href="pii:B0444880747002016">1021</ce:inter-ref>
  <ce:see-also refid="idx68">deductive systems</ce:see-also>
</ce:index-entry>
<ce:index-entry id="idx15">
  <ce:index-heading>equational</ce:index-heading>
  <ce:inter-ref id="interref20"
    xlink:href="pii:B0444880747002016">261</ce:inter-ref>
</ce:index-entry>
</ce:index-entry>
...
<ce:index-entry>
  <ce:index-heading>deductive system</ce:index-heading>
  <ce:inter-ref id="interref174"
    xlink:href="pii:B0444880747002016">891</ce:inter-ref>
</ce:index-entry>
<ce:index-entry>
  <ce:index-heading>for <ce:italic>DL</ce:italic></ce:index-heading>
  <ce:inter-ref id="interref175"
    xlink:href="pii:B0444880747002016">820</ce:inter-ref>
</ce:index-entry>
<ce:index-entry>
  <ce:index-heading>for Temporal Logic</ce:index-heading>
  <ce:inter-ref id="interref176"
    xlink:href="pii:B0444880747002016">1040</ce:inter-ref>
</ce:index-entry>
</ce:index-entry>
```

#### Presentation

```
axiomatizability (see also deductive systems) 1021
equational 261
```

ce:see-also

Chapter 7 – The Elements of the CEP

...  
deductive system 891  
for *DL* 820  
for Temporal Logic 1040

## See also

[ce:see](#)

## ce:simple-para

### Declaration

#### Model (CEPs 1.1.0–1.1.4)

```
<!ELEMENT ce:simple-para ( %spar.data; )*>
<!ATTLIST ce:simple-para
  id ID #IMPLIED
  role CDATA #IMPLIED
  view %view; 'all'>
```

#### Model (CEPs 1.1.5, 1.1.6)

```
<!ELEMENT ce:simple-para ( %spar.data; )*>
<!ATTLIST ce:simple-para
  id ID #IMPLIED
  role CDATA #IMPLIED
  view %view; 'all'>
```

### Description

The element `ce:simple-para` is used to capture paragraphs without floats.

### Usage

A simple paragraph, `ce:simple-para`, belongs to the lowest-level structuring elements. It contains text and objects structured with the elements in `%spar.data;`, and differs from the full paragraph `ce:para` in that it cannot contain any floating objects, i.e. no `ce:float-anchor`.

The attribute `id` can be used to cross-reference to the paragraph.

The attribute `role` allows one to categorize simple paragraphs, and attach a special meaning to them. For instance, it makes it possible to mark a simple paragraph as a “caption”, and handle it in a different way than an ordinary paragraph. Applications should treat roles unknown to them as ordinary simple paragraphs. The role must belong to a list validated by the XML validation tools. At the time of writing, the following roles exist.

- `caption` is used to mark paragraphs of a caption that make up the caption proper and provide a description of the figure or table. It should only be used for simple paragraphs in the element `ce:caption`. Some publications distinguish the paragraphs with this `role` value from those with `role=key`, and may print them, e.g., in bold-face.
- `key` is used to mark paragraphs of a caption that contain information about the keys and symbols used in the figure or table. It should only be used for simple paragraphs in the element `ce:caption`. Some publications distinguish the paragraphs with this `role` value from those with `role=caption`.
- `title` is used to mark the first paragraph of a caption (of a figure, table or textbox) as the title.

Items can appear in compact, standard and extended *views*. The attribute `view` is used to indicate in which views the paragraph must appear. Its default is to appear in all views. See also the section [Views](#) (p. 163).

The fact that simple paragraphs cannot contain floating objects, does not mean that they cannot contain cross-references to floating objects. For instance, if the only place where “Fig. 3” is referenced is in the caption of Fig. 2 — a simple paragraph context — then that caption contains the cross-references but the float anchor of Fig. 3 appears next to the float anchor of Fig. 2.

**See also**

[ce:note-para](#), [ce:para](#)

## ce:small-caps

### Declaration

#### Model (CEPs 1.1.0–1.1.6)

```
<!ELEMENT ce:small-caps ( %richstring.data; )*>
```

### Description

The element `ce:small-caps` is a [font changing element](#) (p. 155). It is used to obtain small caps.

### Usage

To obtain small caps, use lowercase letters within `ce:small-caps`. Uppercase letters in this font may or may not be identical to uppercase letters of the surrounding font.

#### XML

```
<ce:small-caps>This text is in Small Caps</ce:small-caps>.
```

#### Presentation

THIS TEXT IS IN SMALL CAPS.

### Version history

Prior to DTD 5.0, this element was called `scp`.

### See also

For more information see the section on [text effects](#) (p. 155). See also [ce:bold](#), [ce:cross-out](#), [ce:italic](#), [ce:monospace](#), [ce:sans-serif](#), [ce:underline](#).

## ce:source

### Declaration

#### Model (CEPs 1.1.3, 1.1.4)

```
<!ELEMENT ce:source ( %note.data; )*>
```

#### Model (CEP 1.1.5)

```
<!ELEMENT ce:source ( %note.data; )*>
```

#### Model (CEP 1.1.6)

```
<!ELEMENT ce:source ( %note.data; )*>
<!ATTLIST ce:source
  id ID #IMPLIED
  role CDATA #IMPLIED>
```

### Description

The element `ce:source` is available to capture the source of an item.

### Usage

The element `ce:source` is used to describe the source of a `ce:e-component`, a `ce:figure`, a `ce:table`, or a `ce:textbox`.

#### XML

```
<ce:textbox>
  <ce:label>Box 4-6</ce:label>
  <ce:source>From Bethea L, Balazs A: Improving intergenerational
    health care communications, <ce:italic>J Health Commun</ce:italic>
    2(2):129, 1997.</ce:source>
  <ce:textbox-body>
    ...
  </ce:textbox-body>
</ce:textbox>
```

### Version history

This element was added in CEP 1.1.3. In CEP 1.1.5 elements `ce:anchor`, `ce:grant-sponsor` and `ce:grant-number` were added to parameter entity `%note.data;`. The `id` and `role` attributes were added in CEP 1.1.6.



## ce:stereochem

### Declaration

#### Model (CEPs 1.1.0–1.1.5)

```
<!ELEMENT ce:stereochem          ( ce:compound-struct, ( ce:compound-
                                formula | ( ce:compound-name,
                                ce:compound-formula? ) ), ce:compound-
                                info )>
```

#### Model (CEP 1.1.6)

```
<!ELEMENT ce:stereochem          ( ce:compound-struct, ( ce:compound-
                                formula | ( ce:compound-name,
                                ce:compound-formula? ) ), ce:compound-
                                info )>

<!ATTLIST ce:stereochem
  id          ID          #IMPLIED
  role       CDATA      #IMPLIED
  view       %view;     'all'>
```

### Description

A stereochemistry abstract contains the following details of a chemical compound: structure, name, formula, and all available stereochemical information. For each important chemical compound mentioned in a document, the element `ce:stereochem` provides a way to capture it.

### Usage

The element `ce:stereochem` contains four subelements, corresponding to each of the parts of a stereochemistry abstract.

The first is `ce:compound-struct`, which contains a `ce:link` to a picture showing the chemical structure. The second is the optional `ce:compound-name`, which contains the compound's name. The third is the optional `ce:compound-formula`, giving the formula. At least one of these latter two elements should be present. The fourth is `ce:compound-info`, containing one or more `ce:list-item` elements with additional stereochemical information.

#### XML

```
<ce:stereochem>
  <ce:compound-struct><ce:link locator="fx7"/></ce:compound-struct>
  <ce:compound-name><ce:italic>S</ce:italic>-2-
    <ce:italic>t</ce:italic>-Butyldimethylsilylpent-4-enal
  </ce:compound-name>
  <ce:compound-formula>
    C<ce:inf>12</ce:inf>H<ce:inf>22</ce:inf>OSi
  </ce:compound-formula>
  <ce:compound-info>
    <ce:list-item id="li1">
      <ce:para>E.e. &ge; 95%</ce:para>
    </ce:list-item>
    <ce:list-item id="li2">
```

```

    <ce:para>[&alpha;]<ce:sup>25</ce:sup><ce:inf>
      <ce:small-caps>d</ce:small-caps></ce:inf>= ...</ce:para>
  </ce:list-item>
  <ce:list-item id="li3">
    <ce:para>Source of chirality: Sharpless AE</ce:para>
  </ce:list-item>
  <ce:list-item id="li4">
    <ce:para>Absolute configuration:
      <ce:italic>S</ce:italic></ce:para>
  </ce:list-item>
</ce:compound-info>
</ce:stereochem>
<ce:stereochem>
  <ce:compound-struct><ce:link locator="fx8"/></ce:compound-struct>
  <ce:compound-name>(<ce:italic>S</ce:italic>)-2-
    <ce:italic>t</ce:italic>-Butyldimethylsilhex-5-enal
  </ce:compound-name>
  <ce:compound-formula>
    C<ce:inf>12</ce:inf>H<ce:inf>24</ce:inf>OSi
  </ce:compound-formula>
  <ce:compound-info>
    <ce:list-item>
      <ce:para>E.e. &ge; 95%</ce:para>
    </ce:list-item>
    <ce:list-item>
      <ce:para>[&alpha;]<ce:sup>25</ce:sup><ce:inf>
        <ce:small-caps>d</ce:small-caps></ce:inf>= ...</ce:para>
    </ce:list-item>
    ...
  </ce:compound-info>
</ce:stereochem>
<ce:stereochem>
  <ce:compound-struct><ce:link locator="fx9"/></ce:compound-struct>
  ...
</ce:stereochem>

```

## Rendering notes

The stereochemistry abstracts, whose nature is much like keywords, are part of the front-matter, even though they may appear elsewhere in the paper publication. For online applications, the intended usage is to collect the stereochemistry abstracts (e.g., per publication) from the articles and to display them together.

## Version history

The [id](#), [role](#) and [view](#) attributes were added in CEP 1.1.6.

## ce:subtitle

### Declaration

#### Model (CEPs 1.1.0–1.1.6)

```
<!ELEMENT ce:subtitle          ( %textfn.data; )*>
```

### Description

The element `ce:subtitle` contains the subtitle of an article, chapter, or other item.

### Usage

The element `ce:subtitle` is used to capture the subtitle of an item, e.g. a journal article or book chapter. Parts of the title that form an integral part of the title, e.g. separated from the first part by a colon or an em-dash, are not subtitles. Tables of content tend not to contain subtitles.

#### XML

```
<ce:title>The monadic second-order logic of graphs, Part IX:  
Hierarchical decompositions of directed graphs</ce:title>
```

#### Explanation

Here it is not appropriate to make a division in title and subtitle, because the name of part IX is an integral part of the title.

#### XML

```
<ce:title>Hierarchical decompositions of directed graphs</ce:title>  
<ce:subtitle>Part IX in a series of papers devoted to monadic  
second-order logic of graphs</ce:subtitle>
```

### Version history

In DTDs prior to DTD 5.0, the element `sbt` fulfilled the function of both `ce:subtitle` and `ce:alt-subtitle`; the language was specified in the parent `at1` element.

### See also

[ce:alt-title](#), [ce:alt-subtitle](#), [ce:title](#)

## ce:suffix

### Declaration

#### Model (CEPs 1.1.0–1.1.6)

```
<!ELEMENT ce:suffix ( %richstring.data; )*>
```

### Description

A suffix of the author name, e.g. junior or senior, is captured using [ce:suffix](#).

### Usage

A name suffix, mostly denoting a generation, such as “Junior” or “Senior”, is tagged with [ce:suffix](#).

*XML*

```
<ce:given-name>Sammy</ce:given-name>
<ce:surname>Davis</ce:surname>
<ce:suffix>Sr.</ce:suffix>
```

*XML*

```
<ce:given-name>Henry</ce:given-name>
<ce:surname>Ford</ce:surname>
<ce:suffix>III</ce:suffix>
```

### Version history

In DTDs prior to DTD 5.0, this element was called jr.

### See also

[ce:author](#), [ce:degrees](#), [ce:given-name](#), [ce:roles](#), [ce:surname](#)

## ce:sup

### Declaration

#### Model (CEPs 1.1.0–1.1.6)

```
<!ELEMENT ce:sup ( %richstring.data; )*>
<!ATTLIST ce:sup
  loc %loc; "post">
```

### Description

Superscripts are captured using `ce:sup`.

### Usage

Superscripts (superior text) are captured using `ce:sup`.

The optional attribute `loc` can have the values `pre` and `post`, the latter is equivalent to omitting the attribute altogether. If `loc` is equal to `pre` this is to signify that the element belongs to the subsequent object.

*XML*

```
<ce:sup loc="pre">238</ce:sup><ce:inf loc="pre">92</ce:inf>U
```

*Presentation*

$${}^{238}U$$

By default, a super- and subscript appearing at one object will be displayed stacked, i.e. above each other. Staggered super- and subscripts (for example,  $R_j^{i,k}$ ) can only be used in [math mode](#).

### See also

[ce:inf](#)

## ce:surname

### Declaration

#### Model (CEPs 1.1.0–1.1.6)

```
<!ELEMENT ce:surname ( %text.data; )*>
```

### Description

The surname of an author or editor is captured using [ce:surname](#).

### Usage

Together with the element [ce:given-name](#), [ce:surname](#) forms the name of authors or editors.

*XML*

```
<ce:given-name>Franklin D.</ce:given-name>
<ce:surname>Roosevelt</ce:surname>
```

Especially for non-Western persons, it is not always clear or known what the given name and the surname is. In some regions of the world, it is even not uncommon to have just one name. In such cases, [ce:surname](#) may contain the full name of the person.

*XML*

```
<ce:author>
  <ce:surname>Ho Chi Minh</ce:surname>
</ce:author>
```

If the author or editor (especially of a work in the bibliographic reference list) is not a person but an institution or corporation, the name is also tagged using [ce:surname](#). (This should not be confused with a collaboration, [ce:collaboration](#).)

*XML*

```
<ce:surname>National Board of Safety</ce:surname>
```

### See also

[ce:author](#)

## ce:table

### Declaration

#### Model (CEPs 1.1.0–1.1.1)

```
<!ELEMENT ce:table ( ce:label?, ce:caption?, ( tgroup |
ce:link )+, ce:legend?, ce:table-
footnote* )>

<!ATTLIST ce:table
  frame ( top|bottom|topbot|all|sides|none )
        #IMPLIED
  colsep %yesorno; #IMPLIED
  rowsep %yesorno; #IMPLIED
  id ID #IMPLIED
  xmlns CDATA #FIXED %CALS.xmlns;
  xmlns:tb CDATA #FIXED %ESTB.xmlns;>
```

#### Model (CEP 1.1.2)

```
<!ELEMENT ce:table ( ce:label?, ce:caption?, ( %copy-
right; )?, ( tgroup | ce:link )+,
ce:legend?, ce:table-footnote* )>

<!ATTLIST ce:table
  frame ( top|bottom|topbot|all|sides|none )
        #IMPLIED
  colsep %yesorno; #IMPLIED
  rowsep %yesorno; #IMPLIED
  id ID #IMPLIED
  xmlns CDATA #FIXED %CALS.xmlns;
  xmlns:tb CDATA #FIXED %ESTB.xmlns;>
```

#### Model (CEPs 1.1.3–1.1.6)

```
<!ELEMENT ce:table ( ce:label?, ce:caption?, ce:source?,
( %copyright; )?, ( tgroup |
ce:link )+, ce:legend?, ce:table-
footnote* )>

<!ATTLIST ce:table
  frame ( top|bottom|topbot|all|sides|none )
        #IMPLIED
  colsep %yesorno; #IMPLIED
  rowsep %yesorno; #IMPLIED
  id ID #IMPLIED
  xmlns CDATA #FIXED %CALS.xmlns;
  xmlns:tb CDATA #FIXED %ESTB.xmlns;>
```

### Description

A table is captured with [ce:table](#).

### Usage

Aligning text in rows and columns is done using tables. The element [ce:table](#) is used to capture a table. Two kinds of tables are distinguished: displayed tables and floating tables.

Displayed tables are contained within the container element `ce:display`. They appear, surrounded by some white space, where they are mentioned in the text.

Floating tables are grouped, together with the other floating objects such as figures, in a `ce:floats` container at the beginning of the document. Floating tables must be referred to from within the text using a `ce:cross-ref` or a `ce:cross-refs` and a `ce:float-anchor` is used to indicate the position near to which the floating table must appear. So, each floating table is referenced by at least one cross-reference and exactly one float anchor.

*XML*

```
see <ce:cross-refs refid="tbl1 tbl2 tbl3">Tables
1&ndash;3</ce:cross-ref><ce:float-anchor refid="tbl1"/>
<ce:float-anchor refid="tbl2"/><ce:float-anchor refid="tbl3"/>
```

A table begins with a `ce:label` (mandatory for floating tables) and an optional `ce:caption` with a description of the table. There can be multiple captions for different languages and/or roles; each caption must have a different role or language. The optional `ce:copyright` element is used if the copyright owner of the table differs from the copyright owner of the document. The optional `ce:source` element is used to describe the source of the table.

The actual table is contained in `tgroup` elements, and/or is delivered as images, `ce:link`. The `tgroup` contains an extended CALS table, described in more detail in Chapter 10.

Below the tabular content the legend, `ce:legend`, and table footnotes, `ce:table-footnote`, are found.

## Version history

The subelement `ce:copyright` was introduced in CEP 1.1.2. At the same time, the caption was made repeatable. Subelement `ce:source` was introduced in CEP 1.1.3.

## See also

For more information, see Chapter 10.



## ce:table-footnote

### Declaration

#### Model (CEPs 1.1.0–1.1.5)

```
<!ELEMENT ce:table-footnote ( ce:label, ce:note-para+ )>
<!ATTLIST ce:table-footnote
  id ID #REQUIRED>
```

#### Model (CEP 1.1.6)

```
<!ELEMENT ce:table-footnote ( ce:label, ce:note-para+ )>
<!ATTLIST ce:table-footnote
  id ID #REQUIRED
  role CDATA #IMPLIED>
```

### Description

A table footnote is a footnote referenced and displayed within a table, and coded with `ce:table-footnote`.

### Usage

The element `ce:table-footnote` occurs zero or more times at the end of `ce:table`, after the optional `ce:legend` and contains the table footnotes.

The first subelement of `ce:table-footnote` is a mandatory `ce:label` element. It contains the symbol of the table footnote with implied presentation style, i.e., if the style of the footnote symbol is a superior letter, the `ce:label` contains only the letter.

The text of the table footnote is contained in one or more note paragraphs, `ce:note-para`.

There must always be a cross-reference to a table footnote. Note that it is not allowed to cross-reference to a table footnote from outside the table in which the table footnote appears.

A table footnote should not be confused with a `ce:legend`.

### Version history

The `role` attribute was added in CEP 1.1.6.

## ce:text

### Declaration

#### Model (CEPs 1.1.0–1.1.6)

```
<!ELEMENT ce:text ( %text.data; )*>
<!ATTLIST ce:text
    id ID #IMPLIED>
```

### Description

The element `ce:text` is a container element for text.

### Usage

Various elements contain `ce:text` as a general container for text with content model `%text.data;`. The exact content of `%text.data;` is described in the section on [Parameter entities](#) (p. 158).

### See also

[ce:textfn](#), [ce:textref](#)

## ce:textbox

### Declaration

#### Model (CEPs 1.1.0–1.1.1)

```
<!ELEMENT ce:textbox ( ce:label?, ce:caption?, ce:copyright?,
ce:textbox-head?, ce:textbox-body,
ce:textbox-tail? )>
<!ATTLIST ce:textbox
id ID #IMPLIED
role CDATA #IMPLIED>
```

#### Model (CEP 1.1.2)

```
<!ELEMENT ce:textbox ( ce:label?, ce:caption*, ( %copy-
right; )?, ce:textbox-head?,
ce:textbox-body, ce:textbox-tail? )>
<!ATTLIST ce:textbox
id ID #IMPLIED
role CDATA #IMPLIED>
```

#### Model (CEPs 1.1.3–1.1.6)

```
<!ELEMENT ce:textbox ( ce:label?, ce:caption*, ce:source?,
( %copyright; )?, ce:textbox-head?,
ce:textbox-body, ce:textbox-tail? )>
<!ATTLIST ce:textbox
id ID #IMPLIED
role CDATA #IMPLIED>
```

### Description

A textbox (in this context written as one word) is an object similar to a figure, but rather than a graphic it contains typeset material, which could be regarded as a small document in its own right, sometimes displayed with a coloured background. The element `ce:textbox` is provided for this purpose.

### Usage

The element `ce:textbox` can be used in a variety of ways. Similar to `ce:figure` it is embedded within `ce:display` or `ce:floats`. A displayed textbox appears in the text at the position where it is used, separated from the surrounding text with white space. A floating textbox, collected among the floats in `ce:floats` appears in the text near the point where a `ce:float-anchor`, pointing to the textbox, is placed.

The name of the textbox, e.g. “Box II”, is contained in the subelement `ce:label`. The `ce:caption` contains one or more paragraphs, `ce:simple-para`, of descriptive text. There can be multiple captions, for different languages and/or roles; each caption must have a different role or language.

The optional subelement `ce:source` is used to describe the source of the figure. The optional subelement `ce:copyright` can be used if the copyright of the textbox differs from the copyright of the document in which it is embedded.

A `ce:textbox` has an `id` attribute, so that it can be (but does not have to be) referred to using `ce:cross-ref` or `ce:cross-refs` (or from a foreign document). A floating textbox must have exactly one `ce:float-anchor` referring to it.

The structure of a textbox is an optional head (`ce:textbox-head`), a body (`ce:textbox-body`) and an optional tail (`ce:textbox-tail`). Simple textboxes will typically only have a body, but more elaborate textboxes with their own author names and bibliographic references exist also. Since the variety in textboxes is large, it contains many optional subelements.

The head, `ce:textbox-head`, begins with a titles sequence containing a title, `ce:title` and a subtitle, `ce:subtitle`, followed by possible combinations of titles and subtitles in an alternative language (`ce:alt-title`, `ce:alt-subtitle`). A sequence of author groups, `ce:author-group`, and an introductory section, `ce:intro`, complete the head.

The body of a textbox may contain paragraphs and sections within a `ce:sections` container and an acknowledgment (`ce:acknowledgment`), and ends with `ce:appendices`.

The tail of a textbox may contain a bibliography (`ce:bibliography`), a further-reading section (`ce:further-reading`), a glossary (`ce:glossary`), and biographies of the authors (`ce:biography`).

Note that an elaborate textbox itself resembles a small article. It may well contain its own figures and tables.

At the time of writing, the following value for `ce:textbox`'s attribute `role` is defined: `pull-quote`. This is used to capture pull quotes, i.e., sentence or phrase excerpted from the main text, often set in large type, used to break up running text and draw the reader's attention.

## Version history

Prior to DTD 5.0, elaborate textboxes were separate SGML instances, declared as SUBDOC in the main file. Such textboxes were called linked textboxes..

As from CEP 1.1.2, the caption is repeatable. Parameter entity `%copyright;` was introduced as well. Subelement `ce:source` was introduced in CEP 1.1.3.

## Light reading

No floating textboxes may be used in CONTENTS-ENTRY-ONLY, HEAD-ONLY or HEAD-AND-TAIL files.

## See also

`ce:display`, `ce:float-anchor`, `ce:floats`, `ce:textbox-body`, `ce:textbox-head`, `ce:textbox-tail`

## ce:textbox-body

### Declaration

#### Model (CEPs 1.1.0–1.1.6)

```
<!ELEMENT ce:textbox-body ( ce:sections, ce:acknowledgment?,  
ce:appendices? )>
```

### Description

The element [ce:textbox-body](#) contains the body of a textbox, with a number of sections, an acknowledgment and appendices.

### Usage

See [ce:textbox](#).

## ce:textbox-head

### Declaration

#### Model (CEPs 1.1.0–1.1.6)

```
<!ELEMENT ce:textbox-head ( ce:title?, ce:subtitle?, ( ce:alt-  
title, ce:alt-subtitle? )*, ce:author-  
group*, ce:intro? )>
```

### Description

The element [ce:textbox-head](#) contains the head of a textbox. It may contain titles and author names, and an introduction.

### Usage

See [ce:textbox](#).

## ce:textbox-tail

### Declaration

#### Model (CEPs 1.1.0–1.1.6)

```
<!ELEMENT ce:textbox-tail      ( ce:bibliography?, ce:further-reading?,  
                                ce:glossary?, ce:biography* )>
```

### Description

The element [ce:textbox-tail](#) contains the tail of a textbox, with a bibliography, a further-reading section, a glossary and biographies.

### Usage

See [ce:textbox](#).

### Version history

Optional subelements [ce:glossary](#) and [ce:biography](#) were introduced in CEP 1.1.1.

## ce:textfn

### Declaration

#### Model (CEPs 1.1.0–1.1.6)

```
<!ELEMENT ce:textfn ( %textfn.data; )*>
<!ATTLIST ce:textfn
          id ID #IMPLIED>
```

### Description

The element `ce:textfn` is a container element for text.

### Usage

Various elements contain `ce:textfn` as a general container for text with content model `%textfn.data;`. The exact content of `%textfn.data;` is described in the section on [Parameter entities](#) (p. 158).

### See also

[ce:text](#), [ce:textref](#)



## ce:textref

### Declaration

#### Model (CEPs 1.1.0–1.1.6)

```
<!ELEMENT ce:textref ( %textref.data; )*>
<!ATTLIST ce:textref
            id ID #IMPLIED>
```

### Description

The element `ce:textref` is a container element for text.

### Usage

Various elements contain `ce:textref` as a general container for text with content model `%textref.data;`. The exact content of `%textref.data;` is described in the section on [Parameter entities](#) (p. 158).

### See also

[ce:text](#), [ce:textfn](#)

## ce:title

### Declaration

#### Model (CEPs 1.1.0–1.1.6)

```
<!ELEMENT ce:title ( %textfn.data; )*>
```

### Description

The element `ce:title` contains the title of an article, chapter, or other item.

### Usage

The element `ce:title` is used to capture the title of an item, e.g. a journal article or book chapter.

*XML*

```
<ce:title>Tag by Tag</ce:title>
```

### Version history

In DTDs prior to DTD 5.0, the element `at1` fulfilled the function of both `ce:title` and `ce:alt-title`; moreover, it contained the subtitle within it.

### See also

[ce:alt-title](#), [ce:alt-subtitle](#), [ce:subtitle](#)

## ce:underline

### Declaration

#### Model (CEPs 1.1.0–1.1.6)

```
<!ELEMENT ce:underline ( %richstring.data; )*>
```

### Description

The element [ce:underline](#) is related to the [font changing elements](#) (p. 155). It is used to obtain underlined text.

### Usage

To obtain underlined text, use [ce:underline](#).

#### XML

```
<ce:underline>This text is underlined</ce:underline>.
```

#### Presentation

This text is underlined.

### See also

For more information see the section on [text effects](#) (p. 155). See also [ce:bold](#), [ce:cross-out](#), [ce:italic](#), [ce:monospace](#), [ce:sans-serif](#).

## ce:vsp

### Declaration

#### Model (CEPs 1.1.0–1.1.6)

```
<!ELEMENT ce:vsp EMPTY>
<!ATTLIST ce:vsp
  sp NMTOKEN "1.0">
```

### Description

The element `ce:vsp` is used to create explicit vertical space.

### Usage

If the need arises to indicate explicit vertical spacing, `ce:vsp` can be used. It has one attribute, `sp`, which determines the amount of vertical space is to be inserted, measured as a multiple of the baseline-to-baseline distance, default 1.0. It is a non-negative floating number.

If `<ce:vsp sp="1.5">` occurs in the running text, this should be displayed as follows: move down by 1.5 “baseline skip” and do not start a new line. However, if it is immediately followed by a `<ce:para>`, `<ce:note-para>` or `<ce:simple-para>` tag, the next paragraph is not indented.

*XML*

```
Text1<ce:vsp/>Text2
```

*Presentation*

```
Text1
  Text2
```

*XML*

```
Text1<ce:vsp sp="2.0"/><ce:para>Text2
```

*Presentation*

```
Text1
```

```
Text2
```

*XML*

```
Text1<ce:para><ce:vsp sp="2.0"/>Text2
```

*Presentation*

```
Text1
```

```
Text2
```

It is not allowed to use `ce:vsp` for creating built-up structures.

## Chapter 8

# Structured bibliographic references

This chapter contains an alphabetic listing of the DTD fragment for structured bibliographic references. This fragment also belongs to the common element pool (CEP 1.1), but its elements have been assigned to a separate namespace. This makes it possible, for instance, that the structure of an author name in a bibliographic reference differs from that in the head of an article: The elements `ce:author` and `sb:author` both exist.

The first section of this chapter contains extensive examples of various types of references and their XML coding. It is followed by detailed descriptions of each of the elements.

## Bibliographic references — Examples

The fragment of the DTD related to bibliographic references is quite extensive. In this section, structured references are illustrated in the form of examples. The rendering given in the examples does not necessarily follow one of the standard presentations for bibliographic references.

The top-level element for a structured bibliographic reference is `sb:reference`. It uses concepts of “contributions” that appear in one or more “hosts”. Four types of hosts exist: issue, book, edited book and electronic host.

### Examples of structured references

The examples in this section are ordered by the type of host.

1. `sb:issue` as `sb:host`
2. `sb:book` as `sb:host`
3. `sb:edited-book` as `sb:host`
4. `sb:e-host` as `sb:host`, and other hosts on the web

Some examples demonstrate additional features.

- Non-English journal article, with an English `sb:translated-title` (Example 4)
- Book originally published in another language, with a translator (Example 7)
- Multiple hosts (Example 9, Example 14, Example 16)
- `sb:book-series` element (Example 12, Example 13)
- A book series published over a period of several years (Example 13)
- Publications on the web other than preprints (Example 15)
- `sb:comment` element (Example 3, Example 7, Example 16)
- `ce:note` element (Example 16)

#### 1. `sb:issue` as `sb:host`

An `sb:issue` contains at least an `sb:series` and an `sb:date`. The `sb:series` contains an `sb:title` or an `sb:translated-title` and optionally an `sb:volume-nr`.

1. Simple journal article, two authors et al., paginated by issue.

*Presentation*

[1] A. Paivio, L.J. Becker, et al., Comparisons through the mind’s eye, *Cognition* 37 (2) (1975) 635–647.

*XML*

```
<ce:bib-reference id="ref1">
<ce:label>[1]</ce:label>
<sb:reference>
  <sb:contribution>
    <sb:authors>
      <sb:author>
        <ce:given-name>A.</ce:given-name>
        <ce:surname>Paivio</ce:surname>
      </sb:author>
      <sb:author>
        <ce:given-name>L. J.</ce:given-name>
        <ce:surname>Becker</ce:surname>
      </sb:author>
    </sb:authors>
  </sb:contribution>
</sb:reference>
</ce:bib-reference>
```

```

    </sb:author>
  </sb:et-al/>
</sb:authors>
<sb:title>
  <sb:maintitle>Comparisons through
    the mind's eye</sb:maintitle>
</sb:title>
</sb:contribution>
<sb:host>
  <sb:issue>
    <sb:series>
      <sb:title>
        <sb:maintitle>Cognition</sb:maintitle>
      </sb:title>
      <sb:volume-nr>37</sb:volume-nr>
    </sb:series>
    <sb:issue-nr>2</sb:issue-nr>
    <sb:date>1975</sb:date>
  </sb:issue>
  <sb:pages>
    <sb:first-page>635</sb:first-page>
    <sb:last-page>647</sb:last-page>
  </sb:pages>
</sb:host>
</sb:reference>
</ce:bib-reference>

```

2. An article in a journal supplement, only first page given. The fact that it is a supplement can in this example be seen from the `sb:issue-nr`. Otherwise, there is no difference with an article in a normal issue.

#### *Presentation*

[2] S. Koczkas, G. Holmberg, L. Wedin, A pilot study of the effect of . . . , Acta Psychiatrica Scandinavica 63 (Suppl. 290) (1981) 328.

#### *XML*

```

<ce:bib-reference id="ref2">
<ce:label>[2]</ce:label>
<sb:reference>
  <sb:contribution>
    <sb:authors>
      <sb:author>
        <ce:given-name>S.</ce:given-name>
        <ce:surname>Koczkas</ce:surname>
      </sb:author>
      <sb:author>
        <ce:given-name>G.</ce:given-name>
        <ce:surname>Holmberg</ce:surname>
      </sb:author>
      <sb:author>
        <ce:given-name>L.</ce:given-name>
        <ce:surname>Wedin</ce:surname>
      </sb:author>
    </sb:authors>
    <sb:title>

```

```

    <sb:maintitle>A pilot study of the effect of ...</sb:maintitle>
  </sb:title>
</sb:contribution>
<sb:host>
  <sb:issue>
    <sb:series>
      <sb:title>
        <sb:maintitle>Acta Psychiatrica Scandinavica</sb:maintitle>
      </sb:title>
      <sb:volume-nr>63</sb:volume-nr>
    </sb:series>
    <sb:issue-nr>Suppl. 290</sb:issue-nr>
    <sb:date>1981</sb:date>
  </sb:issue>
  <sb:pages><sb:first-page>328</sb:first-page></sb:pages>
</sb:host>
</sb:reference>
</ce:bib-reference>

```

3. Entire issue of a journal. In addition to the `sb:title` in the `sb:series` (the journal title), the issue of this example has a title and (guest) editors of its own. The additional text '(special issue)' is tagged as a comment.

This example is typical for special issues.

#### *Presentation*

[3] R. Glaser, L. Bond (Eds.), Testing: concepts and research, American Psychologist 36 (10–12) (1981) (special issue).

#### *XML*

```

<ce:bib-reference id="ref3">
<ce:label>[3]</ce:label>
<sb:reference>
  <sb:host>
    <sb:issue>
      <sb:editors>
        <sb:editor>
          <ce:given-name>R.</ce:given-name>
          <ce:surname>Glaser</ce:surname>
        </sb:editor>
        <sb:editor>
          <ce:given-name>L.</ce:given-name>
          <ce:surname>Bond</ce:surname>
        </sb:editor>
      </sb:editors>
      <sb:title>
        <sb:maintitle>Testing: concepts and research</sb:maintitle>
      </sb:title>
      <sb:series>
        <sb:title>
          <sb:maintitle>American Psychologist</sb:maintitle>
        </sb:title>
        <sb:volume-nr>36</sb:volume-nr>
      </sb:series>
      <sb:issue-nr>10&ndash;12</sb:issue-nr>
      <sb:date>1981</sb:date>
    </sb:issue>
  </sb:host>
</sb:reference>

```



```

    </sb:issue>
  </sb:host>
  <sb:comment>(special issue)</sb:comment>
</sb:reference>
</ce:bib-reference>

```

4. Non-English journal article, with an English `sb:translated-title`. In this example, the language of the article is known and is specified in the `xml:lang` attribute of the `sb:contribution`.

#### Presentation

[4] E.M.H. Assink, N. Verloop, Het aanleren van deel–geheel relaties (Teaching part–whole relations), *Pedagogische Studiën* 54 (1977) 130–142.

#### XML

```

<ce:bib-reference id="ref4">
<ce:label>[4]</ce:label>
<sb:reference>
  <sb:contribution lang-type="iso" xml:lang="nl">
    <sb:authors>
      <sb:author>
        <ce:given-name>E.M.H.</ce:given-name>
        <ce:surname>Assink</ce:surname>
      </sb:author>
      <sb:author>
        <ce:given-name>N.</ce:given-name>
        <ce:surname>Verloop</ce:surname>
      </sb:author>
    </sb:authors>
    <sb:title>
      <sb:maintitle>Het aanleren
        van deel&ndash;geheel relaties</sb:maintitle>
    </sb:title>
    <sb:translated-title>
      <sb:maintitle>Teaching part&ndash;whole
        relations</sb:maintitle>
    </sb:translated-title>
  </sb:contribution>
<sb:host>
  <sb:issue>
    <sb:series>
      <sb:title>
        <sb:maintitle>Pedagogische Studiën</sb:maintitle>
      </sb:title>
      <sb:volume-nr>54</sb:volume-nr>
    </sb:series>
    <sb:date>1977</sb:date>
  </sb:issue>
  <sb:pages>
    <sb:first-page>130</sb:first-page>
    <sb:last-page>142</sb:last-page>
  </sb:pages>
</sb:host>
</sb:reference>
</ce:bib-reference>

```

2. *sb:book* as *sb:host*

An *sb:book* element contains at least an *sb:date*. The author names and the title can in virtually all cases be found in the *sb:contribution*. Only when no author is given, is the *sb:title* element in the *sb:host* used.

5. Monograph. In this example, the *sb:book* element contains, in addition to the *sb:date*, the *sb:edition* and the *sb:publisher*.

*Presentation*

[5] W. Strunk Jr., E.B. White, The elements of style, 3rd ed., Macmillan, New York, 1979.

*XML*

```
<ce:bib-reference id="ref5">
<ce:label>[5]</ce:label>
<sb:reference>
  <sb:contribution>
    <sb:authors>
      <sb:author>
        <ce:given-name>W.</ce:given-name>
        <ce:surname>Strunk</ce:surname>
        <ce:suffix>Jr.</ce:suffix>
      </sb:author>
      <sb:author>
        <ce:given-name>E.B.</ce:given-name>
        <ce:surname>White</ce:surname>
      </sb:author>
    </sb:authors>
    <sb:title>
      <sb:maintitle>The elements of style</sb:maintitle>
    </sb:title>
  </sb:contribution>
  <sb:host>
    <sb:book>
      <sb:edition>3rd ed.</sb:edition><sb:date>1979</sb:date>
      <sb:publisher>
        <sb:name>MacMillan</sb:name>
        <sb:location>New York</sb:location>
      </sb:publisher>
    </sb:book>
  </sb:host>
</sb:reference>
</ce:bib-reference>
```

6. Book without authors. The title is in the *sb:host*.

*Presentation*

[6] College bound seniors, College Board Publications, Princeton, NJ, 1979.

*XML*

```
<ce:bib-reference id="ref6">
<ce:label>[6]</ce:label>
<sb:reference>
  <sb:host>
    <sb:book>
      <sb:title>
        <sb:maintitle>College bound seniors</sb:maintitle>
      </sb:title>
    </sb:book>
  </sb:host>
</sb:reference>
</ce:bib-reference>
```

```

    </sb:title>
    <sb:date>1979</sb:date>
    <sb:publisher>
      <sb:name>College Board Publications</sb:name>
      <sb:location>Princeton, NJ</sb:location>
    </sb:publisher>
  </sb:book>
</sb:host>
</sb:reference>
</ce:bib-reference>

```

7. Book originally published in another language, with a translator.<sup>3</sup> In this example the original title and the original language are not given.

*Presentation*

[7] A.R. Luria, The mind of a mnemonist (L. Solotarof, Trans.) Avon books, New York, 1969 (Original work published 1965)

*XML*

```

<ce:bib-reference id="ref7">
<ce:label>[7]</ce:label>
<sb:reference>
  <sb:contribution>
    <sb:authors>
      <sb:author>
        <ce:given-name>A.R.</ce:given-name>
        <ce:surname>Luria</ce:surname>
      </sb:author>
    </sb:authors>
    <sb:title>
      <sb:maintitle>The mind of a mnemonist</sb:maintitle>
    </sb:title>
  </sb:contribution>
  <sb:comment>(L. Solotarof, Trans.)</sb:comment>
  <sb:host>
    <sb:book>
      <sb:date>1969</sb:date>
      <sb:publisher>
        <sb:name>Avon books</sb:name>
        <sb:location>New York</sb:location>
      </sb:publisher>
    </sb:book>
  </sb:host>
  <sb:comment>(Original work published 1965)</sb:comment>
</sb:reference>
</ce:bib-reference>

```

**3. *sb:edited-book* as *sb:host***

An `sb:edited-book` contains at least an `sb:date`. When the `sb:host` is an `sb:edited-book`, the `sb:contribution` usually is an article or a chapter in that book. In that case there is an `sb:title` in both the `sb:contribution` and the `sb:host`, much like an article in an `sb:issue`.

8. Article or chapter in edited book.

3. There is no separate element for translator.

*Presentation*

[8] A.S. Gurman, D.P. Kniskern, Family therapy outcome research: knowns and unknowns, in: A.S. Gurman, D.P. Kniskern (Eds.), Handbook of family therapy, Brunner/Mazel, New York, 1981, pp. 742–775.

*XML*

```
<ce:bib-reference id="ref8">
<ce:label>[8]</ce:label>
<sb:reference>
  <sb:contribution>
    <sb:authors>
      <sb:author>
        <ce:given-name>A.S.</ce:given-name>
        <ce:surname>Gurman</ce:surname>
      </sb:author>
      <sb:author>
        <ce:given-name>D.P.</ce:given-name>
        <ce:surname>Kniskern</ce:surname>
      </sb:author>
    </sb:authors>
    <sb:title>
      <sb:maintitle>Family therapy outcome research:
        knowns and unknowns</sb:maintitle>
    </sb:title>
  </sb:contribution>
  <sb:host>
    <sb:edited-book>
      <sb:editors>
        <sb:editor>
          <ce:given-name>A.S.</ce:given-name>
          <ce:surname>Gurman</ce:surname>
        </sb:editor>
        <sb:editor>
          <ce:given-name>D.P.</ce:given-name>
          <ce:surname>Kniskern</ce:surname>
        </sb:editor>
      </sb:editors>
      <sb:title>
        <sb:maintitle>Handbook of family therapy</sb:maintitle>
      </sb:title>
      <sb:date>1981</sb:date>
      <sb:publisher>
        <sb:name>Brunner/Mazel</sb:name>
        <sb:location>New York</sb:location>
      </sb:publisher>
    </sb:edited-book>
    <sb:pages>
      <sb:first-page>742</sb:first-page>
      <sb:last-page>775</sb:last-page>
    </sb:pages>
  </sb:host>
</sb:reference>
</ce:bib-reference>
```

9. Article in edited book, reprinted from another source.

*Presentation*

[9] C.E. Sluzki, J. Beavin, Symmetry and complementarity, in: P. Watzlawick, J.H. Weakland (Eds.), *The interactional view*, Norton, New York, 1977, pp. 71–87. Reprinted from: *Acta Psiquiatrica y Psicologica de America Latina* 11 (1965) 321–330.

*XML*

```
<ce:bib-reference id="ref9">
<ce:label>[9]</ce:label>
<sb:reference>
  <sb:contribution>
    <sb:authors>
      <sb:author>
        <ce:given-name>C.E.</ce:given-name>
        <ce:surname>Sluzki</ce:surname>
      </sb:author>
      <sb:author>
        <ce:given-name>J.</ce:given-name>
        <ce:surname>Beavin</ce:surname>
      </sb:author>
    </sb:authors>
    <sb:title>
      <sb:maintitle>Symmetry and complementarity</sb:maintitle>
    </sb:title>
  </sb:contribution>
  <sb:host>
    <sb:edited-book>
      <sb:editors>
        <sb:editor>
          <ce:given-name>P.</ce:given-name>
          <ce:surname>Watzlawick</ce:surname>
        </sb:editor>
        <sb:editor>
          <ce:given-name>J.H.</ce:given-name>
          <ce:surname>Weakland</ce:surname>
        </sb:editor>
      </sb:editors>
      <sb:title>
        <sb:maintitle>The interactional view</sb:maintitle>
      </sb:title>
      <sb:date>1977</sb:date>
      <sb:publisher>
        <sb:name>Norton</sb:name>
        <sb:location>New York</sb:location>
      </sb:publisher>
    </sb:edited-book>
    <sb:pages>
      <sb:first-page>71</sb:first-page>
      <sb:last-page>87</sb:last-page>
    </sb:pages>
  </sb:host>
  <sb:comment>Reprinted from:</sb:comment>
</sb:host>
  <sb:issue>
    <sb:series>
      <sb:title>
```

```

        <sb:maintitle>Acta Psiquiatrica y Psicologica
        de America Latina</sb:maintitle>
    </sb:title>
    <sb:volume-nr>11</sb:volume-nr>
</sb:series>
    <sb:date>1965</sb:date>
</sb:issue>
    <sb:pages>
        <sb:first-page>321</sb:first-page>
        <sb:last-page>330</sb:last-page>
    </sb:pages>
</sb:host>
</sb:reference>
</ce:bib-reference>

```

10. Article in proceedings published as a book. A proceedings volume is an `sb:edited-book`. It may have conference info in the `sb:conference` element.

*Presentation*

[10] T.E. Chaddock, Gastric emptying of a nutritionally balanced diet, in: E.E. Daniel (Ed.), Proceedings of the Fourth International Symposium on Gastrointestinal Motility, ISGM4, 4–8 September 1973, Seattle, WA, Mitchell Press, Vancouver, British Columbia, Canada, 1974, pp. 83–92.

*XML*

```

<ce:bib-reference id="ref10">
<ce:label>[10]</ce:label>
<sb:reference>
    <sb:contribution>
        <sb:authors>
            <sb:author>
                <ce:given-name>T.E.</ce:given-name>
                <ce:surname>Chaddock</ce:surname>
            </sb:author>
        </sb:authors>
        <sb:title>
            <sb:maintitle>Gastric emptying of a nutritionally
            balanced diet</sb:maintitle>
        </sb:title>
    </sb:contribution>
    <sb:host>
        <sb:edited-book>
            <sb:editors>
                <sb:editor>
                    <ce:given-name>E.E.</ce:given-name>
                    <ce:surname>Daniel</ce:surname>
                </sb:editor>
            </sb:editors>
            <sb:title>
                <sb:maintitle>Proceedings of the Fourth International
                Symposium on Gastrointestinal Motility</sb:maintitle>
            </sb:title>
            <sb:conference>ISGM4, 4&ndash;8 September 1973,
            Seattle, WA</sb:conference>
            <sb:date>1974</sb:date>
            <sb:publisher>

```

```

    <sb:name>Mitchell Press</sb:name>
    <sb:location>Vancouver, British Columbia,
        Canada</sb:location>
  </sb:publisher>
</sb:edited-book>
<sb:pages>
  <sb:first-page>83</sb:first-page>
  <sb:last-page>92</sb:last-page>
</sb:pages>
</sb:host>
</sb:reference>
</ce:bib-reference>

```

11. Edited book. In this example the whole edited book is cited and therefore the element `sb:contribution` is absent.

*Presentation*

[11] S. Letheridge, C.R. Cannon (Eds.), Bilingual education, Praeger, New York, 1980.

*XML*

```

<ce:bib-reference id="ref11">
<ce:label>[11]</ce:label>
<sb:reference>
  <sb:host>
    <sb:edited-book>
      <sb:editors>
        <sb:editor>
          <ce:given-name>S.</ce:given-name>
          <ce:surname>Letheridge</ce:surname>
        </sb:editor>
        <sb:editor>
          <ce:given-name>C.R.</ce:given-name>
          <ce:surname>Cannon</ce:surname>
        </sb:editor>
      </sb:editors>
      <sb:title>
        <sb:maintitle>Bilingual education</sb:maintitle>
      </sb:title>
      <sb:date>1980</sb:date>
      <sb:publisher>
        <sb:name>Praeger</sb:name>
        <sb:location>New York</sb:location>
      </sb:publisher>
    </sb:edited-book>
  </sb:host>
</sb:reference>
</ce:bib-reference>

```

12. A volume in a multi-volume edited work. The difference with a single-volume edited work, is the presence of an `sb:book-series` element. The `sb:book-series` contains an `sb:series` element and optionally the editors of the series. The `sb:series` element contains the series title and optionally the `sb:volume-nr`. The volume may have its own editors and title, as shown in this example.

*Presentation*

[12] J.G. Wilson (Ed.), Basic teratology, in: J.G. Wilson, F.C. Fraser (Eds.), Handbook of

teratology, vol. 1, Plenum Press, New York, 1977–1978.

*XML*

```
<ce:bib-reference id="ref12">
<ce:label>[12]</ce:label>
<sb:reference>
  <sb:host>
    <sb:edited-book>
      <sb:editors>
        <sb:editor>
          <ce:given-name>J.G.</ce:given-name>
          <ce:surname>Wilson</ce:surname>
        </sb:editor>
      </sb:editors>
      <sb:title>
        <sb:maintitle>Basic teratology</sb:maintitle>
      </sb:title>
      <sb:book-series>
        <sb:editors>
          <sb:editor>
            <ce:given-name>J.G.</ce:given-name>
            <ce:surname>Wilson</ce:surname>
          </sb:editor>
          <sb:editor>
            <ce:given-name>F.C.</ce:given-name>
            <ce:surname>Fraser</ce:surname>
          </sb:editor>
        </sb:editors>
        <sb:series>
          <sb:title>
            <sb:maintitle>Handbook of teratology</sb:maintitle>
          </sb:title>
          <sb:volume-nr>Vol. 1</sb:volume-nr>
        </sb:series>
      </sb:book-series>
      <sb:date>1977</sb:date>
      <sb:publisher>
        <sb:name>Plenum Press</sb:name>
        <sb:location>New York</sb:location>
      </sb:publisher>
    </sb:edited-book>
  </sb:host>
</sb:reference>
</ce:bib-reference>
```

13. A multi-volume edited work, publication over more than one year. In this example the whole series is cited; therefore the `sb:contribution` element is absent, and the `sb:edited-book` contains only elements that belong to the series: `sb:book-series`, `sb:dates` and an `sb:publisher`. The fact that the series was published over a period of several years, is expressed by the presence of multiple `sb:dates`.

*Presentation*

[13] J.G. Wilson, F.C. Fraser (Eds.), Handbook of teratology, Vols. 1–4, Plenum Press, New York, 1977–1978.

*XML*



```

<ce:bib-reference id="ref13">
<ce:label>[13]</ce:label>
<sb:reference>
  <sb:host>
    <sb:edited-book>
      <sb:book-series>
        <sb:editors>
          <sb:editor>
            <ce:given-name>J.G.</ce:given-name>
            <ce:surname>Wilson</ce:surname>
          </sb:editor>
          <sb:editor>
            <ce:given-name>F.C.</ce:given-name>
            <ce:surname>Fraser</ce:surname>
          </sb:editor>
        </sb:editors>
        <sb:series>
          <sb:title>
            <sb:maintitle>Handbook of teratology</sb:maintitle>
          </sb:title>
          <sb:volume-nr>Vols. 1&ndash;4</sb:volume-nr>
        </sb:series>
      </sb:book-series>
      <sb:date>1977</sb:date>
      <sb:date>1978</sb:date>
      <sb:publisher>
        <sb:name>Plenum Press</sb:name>
        <sb:location>New York</sb:location>
      </sb:publisher>
    </sb:edited-book>
  </sb:host>
</sb:reference>
</ce:bib-reference>

```

#### 4. *sb:e-host* as *sb:host*, and other hosts on the web

An *sb:e-host* cannot at the same time be an *sb:issue*, *sb:book* or *sb:edited-book*. Therefore it is mainly used for articles on the web that do not belong to any of the other types of host, mostly for preprints. However, one of the examples below shows how a book can have an *sb:e-host* as one of its hosts.

14. An electronic host, *sb:e-host*, consists of a *ce:inter-ref* element and an optional *sb:date*. Formally, the *ce:inter-ref* is optional too, but in practice it is not.

In this example the *sb:e-host* contains the preprint, and the *sb:issue* contains the printed article. It also often occurs that the *sb:e-host* is the only host.

##### *Presentation*

[14] F. Yu, X.-S. Wu, Phys. Rev. Lett. 68 (1992) 2996. hep-th/9112009.

##### *XML*

```

<ce:bib-reference id="ref14">
<ce:label>[14]</ce:label>
<sb:reference>
  <sb:contribution>
    <sb:authors>

```

```

    <sb:author>
      <ce:given-name>F.</ce:given-name>
      <ce:surname>Yu</ce:surname>
    </sb:author>
    <sb:author>
      <ce:given-name>X.-S.</ce:given-name>
      <ce:surname>Wu</ce:surname>
    </sb:author>
  </sb:authors>
</sb:contribution>
<sb:host>
  <sb:issue>
    <sb:series>
      <sb:title>
        <sb:maintitle>Phys. Rev. Lett.</sb:maintitle>
      </sb:title>
      <sb:volume-nr>68</sb:volume-nr>
    </sb:series>
    <sb:date>1992</sb:date>
  </sb:issue>
  <sb:pages><sb:first-page>2996</sb:first-page></sb:pages>
</sb:host>
<sb:host>
  <sb:e-host>
    <ce:inter-ref id="interref37"
      xlink:role="http://www.elsevier.com/xml/linking-roles/preprint"
      xlink:href="arxiv:/hep-th/9112009">hep-th/9112009</ce:inter-ref>
  </sb:e-host>
</sb:host>
</sb:reference>
</ce:bib-reference>

```

15. Article in proceedings, published on the web. In this example the host is a proceedings, hence an `sb:edited-book`, even though it is published solely on the web (or that is the only publication given). The `sb:title` of the `sb:contribution` contains a `ce:inter-ref` element with a leading to a file for this specific article. In addition, the URL of the proceedings is tagged as an `ce:inter-ref` element in the `sb:title` of the `sb:host`.

#### *Presentation*

[15] F. Dougli and Th. Ball, [Tracking and viewing changes on the web](#), in: *Proc. 1996 USENIX Technical Conference*, January 1996.

#### *XML*

```

<ce:bib-reference id="ref15">
  <ce:label>[15]</ce:label>
  <sb:reference>
    <sb:contribution>
      <sb:authors>
        <sb:author>
          <ce:given-name>F.</ce:given-name>
          <ce:surname>Dougli</ce:surname>
        </sb:author>
        <sb:author>
          <ce:given-name>Th.</ce:given-name>
          <ce:surname>Ball</ce:surname>
        </sb:author>
      </sb:authors>
    </sb:contribution>
  </sb:reference>
</ce:bib-reference>

```

```

    </sb:author>
  </sb:authors>
  <sb:title>
    <sb:maintitle>
      <ce:inter-ref id="interref38"
        xlink:href="http://www.research.att.com/papers/aide.ps.gz">
        Tracking and viewing changes on the web
      </ce:inter-ref>
    </sb:maintitle>
  </sb:title>
</sb:contribution>
<sb:host>
  <sb:edited-book>
    <sb:title>
      <sb:maintitle>
        <ce:inter-ref id="interref39"
          xlink:role="http://www.elsevier.com/xml/linking-roles/text/html"
          xlink:href="http://usenix.org/sd96.html">Proc. 1996 USENIX
          Technical Conference</ce:inter-ref>
      </sb:maintitle>
    </sb:title>
    <sb:date>January 1996</sb:date>
  </sb:edited-book>
</sb:host>
</sb:reference>
</ce:bib-reference>

```

16. Article with maximum usage of comments: an `sb:comment` before the `sb:contribution`, an `sb:comment` before each of the `sb:hosts`, and an `sb:comment` after the last `sb:host`. It also has a `ce:note`.

#### *Presentation*

[16] See the references in H.A. Buchdahl, *The Concepts of Classical Thermodynamics*, first published by Cambridge University Press, Cambridge, 1966, also available electronically as: [The Concepts of Classical Thermodynamics](#) (last updated 1999). This reference discusses the basic concepts in a very thorough manner. Its literature list is a main entry point into the discipline.

#### *XML*

```

<ce:bib-reference id="ref16"><ce:label>[16]</ce:label>
<sb:reference>
  <sb:comment>See the references in</sb:comment>
  <sb:contribution>
    <sb:authors>
      <sb:author>
        <ce:given-name>H. A.</ce:given-name>
        <ce:surname>Buchdahl</ce:surname>
      </sb:author>
    </sb:authors>
    <sb:title>
      <sb:maintitle>The Concepts of
        Classical Thermodynamics</sb:maintitle>
    </sb:title>
  </sb:contribution>
  <sb:comment>first published by</sb:comment>

```

```

<sb:host>
  <sb:book>
    <sb:date>1966</sb:date>
    <sb:publisher>
      <sb:name>Cambridge University Press</sb:name>
      <sb:location>Cambridge</sb:location>
    </sb:publisher>
  </sb:book>
</sb:host>
<sb:comment>also available electronically as:</sb:comment>
<sb:host>
  <sb:e-host>
    <ce:inter-ref id="interref40"
      xlink:role="http://www.elsevier.com/xml/linking-roles/text/html"
      xlink:href="http://www.sciencedirect.com/books/5027.html">
      The Concepts of Classical Thermodynamics ☺
    </ce:inter-ref>
  </sb:e-host>
</sb:host>
<sb:comment>(last updated 1999)</sb:comment>
</sb:reference>
<ce:note>
  <ce:simple-para>This reference discusses the basic concepts in
    a very thorough manner.</ce:simple-para>
  <ce:simple-para>Its literature list is a main entry point
    into the discipline.</ce:simple-para>
</ce:note>
</ce:bib-reference>

```

## sb:author

### Declaration

#### Model (CEPs 1.1.0–1.1.6)

```
<!ELEMENT sb:author          ( %name; )>
```

### Description

Within structured bibliographic references, author names are tagged using `sb:author`.

### Usage

The element `sb:author` has `%name;` as its content model. That means that it contains a `ce:surname` and optionally a `ce:given-name` in any order, possibly followed by a `ce:suffix`. For more details, see those elements.

*XML*

```
<sb:author>
  <ce:given-name>D.E.</ce:given-name>
  <ce:surname>Knuth</ce:surname>
</sb:author>
```

*XML*

```
<sb:author>
  <ce:surname>Liszt</ce:surname>
  <ce:given-name>Ferenc</ce:given-name>
</sb:author>
```

*XML*

```
<sb:author>
  <ce:surname>National Institute of Health</ce:surname>
</sb:author>
```

### See also

Structured references are explained in more detail in the section [Bibliographic references](#) (p. 394).

## sb:authors

### Declaration

#### Model (CEPs 1.1.0–1.1.6)

```
<!ELEMENT sb:authors          ( ( sb:collaboration | ( sb:author,
                                sb:et-al? ) )+ )>
```

### Description

Within structured bibliographic references, `sb:authors` is a container element for the authors of the reference.

### Usage

The element `sb:authors` consists of a non-empty sequence of collaborations (`sb:collaboration`) and authors (`sb:author`) possibly followed by an `sb:et-al` element. For more information, see these elements.

*XML*

```
<sb:authors>
  <sb:author>
    <ce:given-name>D.C.</ce:given-name>
    <ce:surname>Coleman</ce:surname>
  </sb:author>
  <sb:et-al/>
</sb:authors>
```

### See also

Structured references are explained in more detail in the section [Bibliographic references](#) (p. 394).

## sb:book

### Declaration

#### Model (CEPs 1.1.0–1.1.6)

```
<!ELEMENT sb:book          ( ( %sb:titles; )?, sb:edition?,
                             sb:book-series?, sb:date+,
                             sb:publisher?, sb:isbn? )>
```

### Description

Within bibliographic references, the structure of a book is captured using `sb:book`.

### Usage

One of the four type of “hosts” is `sb:book`, used when structuring references to (non-edited) books.

Such simple books, or monographs, are considered as a single “contribution” occurring in the host. Consequently, the author names and the title of the work can in virtually all cases be found in the `sb:contribution`. The optional titles within the `sb:book` are used when no author is given. An average book, therefore, only contains the following subelements.

The optional subelement `sb:edition` contains information about the edition of the book. The date of publication of the book — or, more accurately, the host, for a book may well appear in different hosts — is captured using `sb:date`. A book can have more than one date. The name and place of the publisher are contained within `sb:publisher`. Finally, the element `sb:isbn` can be used to capture the ISBN number of the referenced book, if required.

#### XML

```
<sb:contribution>
  <sb:authors>
    <sb:author>
      <ce:given-name>B.M.</ce:given-name>
      <ce:surname>Travis</ce:surname>
    </sb:author>
    <sb:author>
      <ce:given-name>D.</ce:given-name>
      <ce:surname>Waldt</ce:surname>
    </sb:author>
  </sb:authors>
  <sb:title>
    <sb:maintitle>The SGML Implementation Guide</sb:maintitle>
    <sb:subtitle>A Blueprint for SGML Migration</sb:subtitle>
  </sb:title>
</sb:contribution>
<sb:host>
  <sb:book>
    <sb:date>1996</sb:date>
    <sb:publisher>
      <sb:name>Springer</sb:name>
      <sb:location>Berlin</sb:location>
```

```

    </sb:publisher>
  </sb:book>
</sb:host>

```

*Presentation*

B. Travis and D. Waldt, The SGML Implementation Guide. A Blueprint for SGML Migration (Springer, Berlin, 1996).

*XML*

```

<sb:host>
  <sb:book>
    <sb:title>
      <sb:maintitle>Quick Course in Microsoft<ce:sup>&reg;</ce:sup>
        Powerpoint<ce:sup>&reg;</ce:sup> 97
      </sb:maintitle>
    </sb:title>
    <sb:date>1997</sb:date>
    <sb:publisher>
      <sb:name>Online Press Inc.</sb:name>
      <sb:location>Bellevue, WA</sb:location>
    </sb:publisher>
  </sb:book>
</sb:host>

```

*Presentation*

Quick Course in Microsoft® Powerpoint® 97 (Online Press Inc., Bellevue, WA, 1997).

*Explanation*

This book has no mention of authors or editors. The title within the `sb:book` is used.

**Version history**

The parameter entity `%sb.titles;` was introduced in CEP 1.1.0.

**See also**

Structured references are explained in more detail in the section [Bibliographic references](#) (p. 394).



## sb:book-series

### Declaration

#### Model (CEPs 1.1.0–1.1.6)

```
<!ELEMENT sb:book-series      ( sb:editors?, sb:series )>
```

### Description

Within bibliographic references, the name of a book series and the volume number of the work within that series are captured using [sb:book-series](#)

### Usage

The element [sb:book-series](#) occurs as an optional element within [sb:book](#) and [sb:edited-book](#). Apart from a mandatory [sb:series](#) subelement, it may contain an editor group. In practice, unlike the names of the editors of an edited book, the names of the editors of a book series are seldom mentioned in bibliographic references.

*XML*

```
<sb:book-series>
  <sb:series>
    <sb:title>
      <sb:maintitle>Lecture Notes in Mathematics</sb:maintitle>
    </sb:title>
    <sb:volume-nr>Vol. 1201</sb:volume-nr>
```

### See also

Structured references are explained in more detail in the section [Bibliographic references](#) (p. 394).

## sb:collaboration

### Declaration

#### Model (CEPs 1.1.0–1.1.6)

```
<!ELEMENT sb:collaboration ( %text.data; )*>
```

### Description

Within structured bibliographic references, the name of a collaboration is tagged using [sb:collaboration](#).

### Usage

A collaboration denotes a group of authors who present themselves under a common name: the collaboration name. In a structured bibliographic reference, it can appear at the same place as where an [sb:author](#) can appear.

If the author is not a person but a government body or another organization, then this is not a collaboration.

### See also

[sb:author](#), [ce:collaboration](#). Structured references are explained in more detail in the section [Bibliographic references](#) (p. 394).

## sb:comment

### Declaration

#### Model (CEPs 1.1.0–1.1.6)

```
<!ELEMENT sb:comment          ( %nondisplay.data; )*>
```

### Description

Comments within structured bibliographic references are captured using [sb:comment](#).

### Usage

The element [sb:comment](#) is used to insert text between the highly structured bibliographic references.

The element [sb:comment](#) can occur before the contribution, between the contribution and the host, and after each host. It holds text which, when rendered, can appear between the highly structured contribution and hosts. Whether the [sb:comment](#) belongs to the host or contribution before or after it cannot be signified.

[sb:comment](#) should not be confused with [ce:note](#).

#### XML

```
<bib-reference id="bib49">
  <ce:label>[49]</ce:label>
  <sb:reference>
    <sb:comment>See the references in</sb:comment>
    <sb:contribution>...</sb:contribution>
    <sb:comment>first published in</sb:comment>
    <sb:host>...</sb:host>
    <sb:comment>also available electronically as</sb:comment>
    <sb:host>...</sb:host>
    <sb:comment>(in Japanese)</sb:comment>
  </sb:reference>
</bib-reference>
```

### Version history

In CEP 1.1.1 the content model was changed to allow for more content (elements [ce:footnote](#) and [ce:anchor](#)).

### See also

[ce:note](#). Structured references are explained in more detail in the section [Bibliographic references](#) (p. 394).

## sb:conference

### Declaration

#### Model (CEPs 1.1.0–1.1.6)

```
<!ELEMENT sb:conference ( %text.data; )*>
```

### Description

Within bibliographic references, it may happen that conference information (such as the location or the date) is present for the proceedings of a conference, appearing as an [sb:issue](#) or an [sb:edited-book](#). This information, seldom present in actual bibliographic references, can be captured using [sb:conference](#).

### See also

Structured references are explained in more detail in the section [Bibliographic references](#) (p. 394).

## sb:contribution

### Declaration

#### Model (CEPs 1.1.0–1.1.6)

```
<!ELEMENT sb:contribution      ( sb:authors?, ( %sb.titles; )? )>
<!ATTLIST sb:contribution
  langtype          %language-type;    "en"
  xml:lang          %iso639;           #IMPLIED>
```

### Description

Each structured bibliographic reference is divided into an “[sb:contribution](#)” and one or more “[sb:host](#)”s.

### Usage

Bibliographic references are structurally split into a “contribution” and one or more “hosts”. Contribution is the abstract term used for the referenced object separated from its physical appearance. An [sb:contribution](#) can be a scientific article or book, but also a map, audiotape, Internet page, etc.—any object referred to in a reference list. Some examples: In a reference to an article in a journal issue or in an edited volume, the [sb:contribution](#) contains the author names and title of the article. A monograph (simple book) is seen as one contribution within a host.

It is possible to specify the language of the contribution using the attributes [langtype](#) and [xml:lang](#), which takes its values in [%iso639](#); i.e., the [ISO 639 list of language codes](#) (p. 162). The language type ([%language-type](#);) gives an indication about the language in which the contribution is written. It can take the following values: `en` (English); `non-en` (an unspecified non-English language); `iso` (a language specified in the [xml:lang](#) attribute). The value `unknown` is used when the reference gives no indication whatsoever about the language.

The attribute [xml:lang](#) is mandatory when [langtype](#) has the value `iso` and may not be present for other values of [langtype](#).

A contribution consists of an optional author group ([sb:authors](#)), and optional title and/or translated title.

### Version history

The parameter entity [%sb.titles](#); was introduced in CEP 1.1.0.

### See also

Structured references are explained in more detail in the section [Bibliographic references](#) (p. 394).

## sb:date

### Declaration

#### Model (CEPs 1.1.0–1.1.6)

```
<!ELEMENT sb:date ( %richstring.data; )*>
```

### Description

Within structured bibliographic references, dates of publication are tagged using `sb:date`.

### Usage

The element `sb:date` contains the date of publication of a structured bibliographic reference. This may contain merely a year or a full date, depending on the author's manuscript. For books or edited books multiple dates can be given — these must be captured in different `sb:date` elements.

*XML*

```
<sb:date>1999</sb:date>
```

*XML*

```
<sb:date>12 December 1999</sb:date>
```

*XML*

```
<sb:date>1975</sb:date><sb:date>1997</sb:date>
```

In name/date references, references that share the same author names and year are listed as "(Böhm, 1999a)". The "a" is *not* part of the `sb:date`; it is found in the `ce:label` subelement of `ce:bib-reference`, *q.v.*

### See also

Structured references are explained in more detail in the section [Bibliographic references](#) (p. 394).

## sb:edited-book

### Declaration

#### Model (CEPs 1.1.0–1.1.6)

```
<!ELEMENT sb:edited-book ( sb:editors?, ( %sb.titles; )?,  
sb:conference?, sb:edition?, sb:book-  
series?, sb:date+, sb:publisher?,  
sb:isbn? )>
```

### Description

Within bibliographic references, element `sb:edited-book` is used to capture the structure of book which contains contributions from several authors, edited by an editor.

### Usage

One of the four type of “hosts” is `sb:edited-book`, used when structuring references to edited books, i.e., books that contain contributions from several authors.

The first subelement, the optional editor group (`sb:editors`) contains the names of the editors of the work. This is followed by the `sb:title` and/or the `sb:translated-title`.

The edited book can be the proceedings of a conference, and if conference details, such as place and date of the conference, are present these can be captured with `sb:conference`. In practice, bibliographic references rarely contain such detailed information.

Information about the edition can be captured with `sb:edition`. If the edited book is itself a member of a book series, this can be recorded using `sb:book-series`. The publication date(s) are tagged with `sb:date`.

The name and place of the publisher are contained in `sb:publisher`.

Finally, the element `sb:isbn` can be used to capture the ISBN number of the referenced book, if required.

### Version history

The parameter entity `%sb.titles;` was introduced in CEP 1.1.0.

### See also

Structured references are explained in more detail in the section [Bibliographic references](#) (p. 394).

## sb:edition

### Declaration

#### Model (CEPs 1.1.0–1.1.6)

```
<!ELEMENT sb:edition ( %richstring.data; )*>
```

### Description

Within structured bibliographic references, information about the edition of a book is captured using [sb:edition](#).

### Usage

The element [sb:edition](#) is an optional element for a book or an edited book, and contains information about the edition.

#### XML

```
<sb:edition>second edition</sb:edition>  
<sb:edition>3rd ed.</sb:edition>  
<sb:edition>revised edition</sb:edition>
```

### See also

Structured references are explained in more detail in the section [Bibliographic references](#) (p. 394).



## sb:editor

### Declaration

#### Model (CEPs 1.1.0–1.1.6)

```
<!ELEMENT sb:editor          ( %name; )>
```

### Description

Within structured bibliographic references, editor names are tagged using [sb:editor](#).

### Usage

The element [sb:editor](#) has [%name](#); as its content model, which means that it contains a [ce:surname](#) and an optional [ce:given-name](#) in any order, and an optional [ce:suffix](#). For more details, see those elements.

### See also

Structured references are explained in more detail in the section [Bibliographic references](#) (p. 394).

## sb:editors

### Declaration

#### Model (CEPs 1.1.0–1.1.6)

```
<!ELEMENT sb:editors          ( sb:editor+, sb:et-al? )>
```

### Description

Within bibliographic references, the element `sb:editors` contains one or more editor names and possibly an “et al.” indicator. The element is referred to as editor group.

### Usage

An `sb:book-series`, an `sb:edited-book` and an `sb:issue` can have (guest) editors. The element `sb:editors` is a container element for one or more `sb:editor`s and optionally an `sb:et-al`.

### See also

Structured references are explained in more detail in the section [Bibliographic references](#) (p. 394).

## sb:e-host

### Declaration

#### Model (CEPs 1.1.0–1.1.6)

```
<!ELEMENT sb:e-host          ( ce:inter-ref?, sb:date? )>
```

### Description

The element `sb:e-host` is used to capture references to electronic media.

### Usage

If one of the hosts of a bibliographic reference is a preprint in an electronic preprint archive or another document on an electronic platform, the element `sb:e-host` is used. It may contain a `ce:inter-ref` and/or an `sb:date`, although it is only useful when it contains `ce:inter-ref`.

The hyperlink to the electronic platform is established using `ce:inter-ref`. For detailed information, see that element.

The date of publication can be captured with the `sb:date` subelement.

#### XML

```
<sb:e-host>
  <ce:inter-ref id="interref37"
    xlink:role="http://www.elsevier.com/xml/linking-roles/preprint"
    xlink:href="arxiv:/hep-th/9112009">hep-th/9112009</ce:inter-ref>
</sb:e-host>
```

### See also

Bibliographic references are explained in more detail in the section [Bibliographic references](#) (p. 394).

## sb:et-al

### Declaration

#### Model (CEPs 1.1.0–1.1.6)

```
<!ELEMENT sb:et-al EMPTY>
```

### Description

Within structured bibliographic references, occurrences of the phrase “et al.” are structured with [sb:et-al](#).

### Usage

The element [sb:et-al](#) is used when the bibliographic reference only lists part of the authors or editors.

### See also

Structured references are explained in more detail in the section [Bibliographic references](#) (p. 394).

## sb:first-page

### Declaration

#### Model (CEPs 1.1.0–1.1.6)

```
<!ELEMENT sb:first-page ( %richstring.data; )*>
```

### Description

Within structured bibliographic references, the number of the first page of a publication is tagged using [sb:first-page](#).

### Usage

The element [sb:first-page](#) contains the first page of a bibliographic reference. If the reference has a page *range*, the number of the last page is to be captured using [sb:last-page](#). The element may not contain an en-dash.

*XML*

```
<sb:first-page>121</sb:first-page>
```

*XML*

```
<sb:first-page>A-12</sb:first-page>
```

*XML*

```
<sb:first-page>37v</sb:first-page>
```

### See also

[sb:last-page](#). Structured references are explained in more detail in the section [Bibliographic references](#) (p. 394).

## sb:host

### Declaration

#### Model (CEPs 1.1.0–1.1.6)

```
<!ELEMENT sb:host
    ( ( ( sb:issue, sb:pages? ) | sb:book
      | ( sb:edited-book, sb:pages? ) |
        sb:e-host ), ce:doi? )>
```

### Description

Within bibliographic references, the structure of a host is captured using [sb:host](#).

### Usage

A bibliographic reference is structurally split into a “contribution” and one or more “hosts”. The host is the physical appearance that “contains” the reference. There can be more than one host: a version of an article on the author’s homepage, a version in a journal issue, a version in a spin-off book, a version on ScienceDirect<sup>®</sup>.

A host can be one of four varieties: [sb:issue](#), [sb:book](#), [sb:edited-book](#) or [sb:e-host](#). For more information, see these elements.

In order to locate the contribution within an issue or an edited book, an optional [sb:pages](#) is added to the [sb:host](#).

Each host can have a DOI, captured using the [ce:doi](#) element.

### Version history

Prior to DTD 5.0, the [pages](#) element was contained within elements [issue](#) and [edited-book](#).

### See also

Structured references are explained in more detail in the section [Bibliographic references](#) (p. 394).

## sb:isbn

### Declaration

#### Model (CEPs 1.1.0–1.1.6)

```
<!ELEMENT sb:isbn          ( %string.data; )*>
```

### Description

Within structured bibliographic references, the ISBN of a book is tagged using `sb:isbn`.

### Usage

If in structured references the ISBN of a book needs to be captured, this can be done by the element `sb:isbn`.

In practice, bibliographic references rarely contain ISBNs. The element is very useful, however, in the frontmatter of a book review.

*XML*

```
<sb:isbn>0-13-065567-8</sb:isbn>
```

### See also

[book-review](#). Structured references are explained in more detail in the section [Bibliographic references](#) (p. 394).

## sb:issn

### Declaration

#### Model (CEPs 1.1.0–1.1.6)

```
<!ELEMENT sb:issn ( %string.data; )*>
```

### Description

Within structured bibliographic references, the ISSN of a serial publication is captured using [sb:issn](#).

### Usage

Although this happens rarely in practice, an ISSN of a serial publication can be tagged with [sb:issn](#). This element is an optional element within [sb:series](#).

*XML*

```
<sb:issn>0167-8396</sb:issn>
```

### See also

Structured references are explained in more detail in the section [Bibliographic references](#) (p. 394).



## sb:issue

### Declaration

#### Model (CEPs 1.1.0–1.1.6)

```
<!ELEMENT sb:issue          ( sb:editors?, ( %sb.titles; )?,
                             sb:conference?, sb:series, sb:issue-
                             nr?, sb:date )>
```

### Description

Within bibliographic references, the structure of a journal issue is captured using `sb:issue`.

### Usage

One of the four type of “hosts” is `sb:issue`, used when structuring references to articles in journal issues or to whole journal issues. The article is the “contribution”; the journal issue is the “host”.

The first three subelements of `sb:issue` are an editor group (`sb:editors`), `sb:title` and/or `sb:translated-title`, and conference information (`sb:conference`). These are used when the bibliographic reference contains special issue information.

The titles mentioned above should not be confused with the titles appearing within the subelement `sb:series`, which contains the journal name and optionally the volume number. Each reference to an issue must have a title within `sb:series` (the journal name) but much fewer references will have a title on the `sb:issue` level.

If available, the issue identification can be captured with `sb:issue-nr`.

The last subelement, the mandatory `sb:date`, contains the publication date of the issue. (Most references only have the year.)

The page range on which the article appears is captured within the `sb:pages` element on the `sb:host` level.

#### XML

```
<sb:host>
  <sb:issue>
    <sb:series>
      <sb:title>
        <sb:maintitle>Theoret. Comput. Sci.</sb:maintitle>
      </sb:title>
      <sb:volume-nr>193</sb:volume-nr>
    </sb:series>
    <sb:issue-nr>1-2</sb:issue-nr>
    <sb:date>1998</sb:date>
  </sb:issue>
  <sb:pages>
    <sb:first-page>97</sb:firstpage>
    <sb:last-page>112</sb:lastpage>
  </sb:pages>
</sb:host>
```

*XML*

```
<sb:host>
  <sb:issue>
    <sb:editors>Christer Carlsson and Robert Full&#x00233;r</sb:editors>
    <sb:title>
      <sb:maintitle>Soft Decision Analysis</sb:maintitle>
    </sb:title>
    <sb:series>
      <sb:title>
        <sb:maintitle>Fuzzy Sets and Systems</sb:maintitle>
      </sb:title>
      <sb:volume-nr>115</sb:volume-nr>
    </sb:series>
    <sb:date>2000</sb:date>
  </sb:issue>
</sb:host>
```

**See also**

Structured references are explained in more detail in the section [Bibliographic references](#) (p. 394).

## sb:issue-nr

### Declaration

#### Model (CEPs 1.1.0–1.1.6)

```
<!ELEMENT sb:issue-nr          ( %richstring.data; )*>
```

### Description

Within structured bibliographic references, issue numbers are tagged using `sb:issue-nr`.

### Usage

The element `sb:issue-nr` may contain an issue number or a range of issue numbers.

*XML*

```
<sb:issue-nr>2&#x02013;4</sb:issue-nr>
```

*XML*

```
<sb:issue-nr>Suppl. 1</sb:issue-nr>
```

### See also

Structured references are explained in more detail in the section [Bibliographic references](#) (p. 394).

## sb:last-page

### Declaration

#### Model (CEPs 1.1.0–1.1.6)

```
<!ELEMENT sb:last-page ( %richstring.data; )*>
```

### Description

Within structured bibliographic references, the last page of a page range can be captured using [sb:last-page](#).

### Usage

The number of the last page of a bibliographic reference is contained in [sb:last-page](#). It should always be greater than [sb:first-page](#).

### Copy edit considerations

The number of the last page should always be given in full. That is, if a page range 147–9 is given, [sb:last-page](#) should contain 149. Similarly, in case of page range S155–161, [sb:last-page](#) should contain S161.

### See also

[sb:first-page](#). Structured references are explained in more detail in the section [Bibliographic references](#) (p. 394).

## sb:location

### Declaration

#### Model (CEPs 1.1.0–1.1.6)

```
<!ELEMENT sb:location ( %richstring.data; )*>
```

### Description

Within structured bibliographic references, the location of a publisher can be captured using the element `sb:location`.

### Usage

See `sb:publisher`.

### See also

Structured references are explained in more detail in the section [Bibliographic references](#) (p. 394).

## sb:maintitle

### Declaration

#### Model (CEPs 1.1.0–1.1.6)

```
<!ELEMENT sb:maintitle ( %text.data; )*>
```

### Description

The main title of a structured bibliographic reference is captured using [sb:maintitle](#).

### Usage

See [sb:title](#).

### See also

Structured references are explained in more detail in the section [Bibliographic references](#) (p. 394).

## sb:name

### Declaration

#### Model (CEPs 1.1.0–1.1.6)

```
<!ELEMENT sb:name ( %richstring.data; )*>
```

### Description

Within structured bibliographic references, the name of the publisher is captured using [sb:name](#).

### Usage

See [sb:publisher](#).

### See also

Structured references are explained in more detail in the section [Bibliographic references](#) (p. 394).

## sb:pages

### Declaration

#### Model (CEPs 1.1.0–1.1.6)

```
<!ELEMENT sb:pages          ( sb:first-page, sb:last-page? )>
```

### Description

Within structured bibliographic references, pages or page ranges of a publication are contained in [sb:pages](#).

### Usage

The element [sb:pages](#) contains a mandatory [sb:first-page](#) and an optional [sb:last-page](#).

#### XML

```
<sb:pages>
  <sb:first-page>37</sb:first-page>
  <sb:last-page>51</sb:last-page>
</sb:pages>
```

#### Presentation

37–51

Some layout styles abbreviate 121–127 to 121–7. This should be solved by the style sheet: the last page is always captured as “127”.

### Version history

The element has been moved to the [sb:host](#) level and out of the [sb:issue](#) and [sb:edited-book](#) level.

### See also

Structured references are explained in more detail in the section [Bibliographic references](#) (p. 394).



## sb:publisher

### Declaration

#### Model (CEPs 1.1.0–1.1.6)

```
<!ELEMENT sb:publisher ( sb:name, sb:location? )>
```

### Description

Within structured bibliographic references, the name and place of the publisher of the publication are captured using [sb:publisher](#).

### Usage

The element [sb:publisher](#) contains a mandatory [sb:name](#), the name of the publisher or the imprint, and an optional [sb:location](#), the place or places where the publisher is located.

*XML*

```
<sb:publisher>
  <sb:name>North-Holland</sb:name>
  <sb:location>Amsterdam</sb:location>
</sb:publisher>
```

*XML*

```
<sb:publisher>
  <sb:name>American Mathematical Society</sb:name>
  <sb:location>Providence, RI</sb:location>
</sb:publisher>
```

*XML*

```
<sb:publisher>
  <sb:name>Springer-Verlag</sb:name>
  <sb:location>Heidelberg, Berlin</sb:location>
</sb:publisher>
```

### See also

Structured references are explained in more detail in the section [Bibliographic references](#) (p. 394).

## sb:reference

### Declaration

#### Model (CEPs 1.1.0–1.1.6)

```
<!ELEMENT sb:reference          ( ce:label?, sb:comment?, ( sb:contribution,
                                sb:comment? )?, ( sb:host,
                                sb:comment? )+ )>
<!ATTLIST sb:reference
          id                ID                #IMPLIED
          xmlns:sb         CDATA             #FIXED %ESSB.xmlns;>
```

### Description

The element [sb:reference](#) is used to capture a fully structured reference.

### Usage

A structured reference is contained in an [sb:reference](#) element. Each [sb:reference](#) consists of an optional [sb:contribution](#) and one or more [sb:hosts](#). Comments can be inserted between these elements using [sb:comment](#).

An [sb:reference](#) may have a [ce:label](#) subelement and an [id](#) attribute. These are used if the [sb:reference](#) is part of a multiple reference.

### Version history

Prior to DTD 5.0, this element was called `bb`.

### See also

[sb:comment](#), [sb:contribution](#) and [sb:host](#). Structured references are explained in more detail in the section [Bibliographic references](#) (p. 394).

## sb:series

### Declaration

#### Model (CEPs 1.1.0–1.1.6)

```
<!ELEMENT sb:series          ( ( %sb.titles; ), sb:issn?, sb:volume-  
                               nr? )>
```

### Description

Within structured bibliographic references, the element [sb:series](#) is used to identify serial publications.

### Usage

The element [sb:series](#) is used to capture the journal title and the volume number of an issue appearing in that journal, or the title of a book series and the volume number of a book that appears in a book series. It can also contain the ISSN of the serial publication.

### Version history

The parameter entity [%sb.titles;](#) was introduced in CEP 1.1.0.

### See also

[sb:book-series](#) and [sb:issue](#). Structured references are explained in more detail in the section [Bibliographic references](#) (p. 394).

## sb:subtitle

### Declaration

#### Model (CEPs 1.1.0–1.1.6)

```
<!ELEMENT sb:subtitle          ( %text.data; )*>
```

### Description

The subtitle of a structured bibliographic reference is captured using [sb:subtitle](#).

### Usage

See [sb:title](#).

### See also

Structured references are explained in more detail in the section [Bibliographic references](#) (p. 394).

## sb:title

### Declaration

#### Model (CEPs 1.1.0–1.1.6)

```
<!ELEMENT sb:title ( sb:maintitle, sb:subtitle? )>
```

### Description

Within bibliographic references, titles are tagged using `sb:title`. Depending on the context, this can be the title of an article or a book, the name of a journal or a book series, etc.

### Usage

An `sb:book`, an `sb:contribution`, an `sb:edited-book`, an `sb:issue` and an `sb:series` can have an `sb:title`.

An `sb:title` consists of `sb:maintitle` and optionally `sb:subtitle`. Please refer to `ce:subtitle` for a description of what constitutes a subtitle.

#### XML

```
<sb:title>
  <sb:maintitle>The SGML Implementation Guide</sb:maintitle>
  <sb:subtitle>A Blueprint for SGML Migration</sb:subtitle>
</sb:title>
```

### See also

Structured references are explained in more detail in the section [Bibliographic references](#) (p. 394).

## sb:translated-title

### Declaration

#### Model (CEPs 1.1.0–1.1.6)

```
<!ELEMENT sb:translated-title ( sb:maintitle, sb:subtitle? )>
```

### Description

Within bibliographic references, translated titles are tagged using [sb:translated-title](#).

### Usage

Often, when a contribution is written in a different language, the author has translated the title for the benefit of the reader. A comment “(in Dutch)” or similar is then added to the reference. To this end, [sb:book](#), [sb:contribution](#), [sb:edited-book](#), [sb:issue](#) and [sb:series](#) can have an [sb:translated-title](#).

The element [sb:translated-title](#) consists of a [sb:maintitle](#) as well as an optional [sb:subtitle](#). See [sb:title](#) for more information.

#### XML

```
<sb:contribution>
  <sb:authors>
    <sb:author>
      <sb:given-name>E.M.H.</sb:given-name>
      <sb:surname>Assink</sb:surname>
    </sb:author>
    <sb:author>
      <sb:given-name>N.</sb:given-name>
      <sb:surname>Verloop</sb:surname>
    </sb:author>
  </sb:authors>
  <sb:title>
    <sb:maintitle>Het aanleren van deel&#x02013;geheel
      relaties</sb:maintitle>
  </sb:title>
  <sb:translated-title>
    <sb:maintitle>Teaching part&#x02013;whole
      relations</sb:maintitle>
  </sb:translated-title>
</sb:contribution>
```

### See also

Structured references are explained in more detail in the section [Bibliographic references](#) (p. 394).

## sb:volume-nr

### Declaration

#### Model (CEPs 1.1.0–1.1.6)

```
<!ELEMENT sb:volume-nr ( %richstring.data; )*>
```

### Description

Within structured bibliographic references, volume numbers are tagged using [sb:volume-nr](#).

### Usage

The element [sb:volume-nr](#) may contain a volume number or a range of volume numbers.

*XML*

```
<sb:volume-nr>121</sb:volume-nr>
```

*XML*

```
<sb:volume-nr>XL&#x02013;XLII</sb:volume-nr>
```

### See also

Structured references are explained in more detail in the section [Bibliographic references](#) (p. 394).





## Chapter 9

# MathML

The Elsevier DTD 5.0 family uses MathML for its mathematical formulae. The element `mml:math` can be used inline and as subelement of `ce:formula`.

We refer to specialized MathML documentation for more information about MathML tagging.

MathML exists in two forms known as Presentational MathML and Content MathML. Content MathML captures the meaning of the formula; the presentation of the formula is a derivative thereof. Presentational MathML merely captures the presentation of the formula; math notation is such that the meaning can be derived from the presentation to some extent, but never fully so.

It is expected that Content MathML cannot be written or keyed in by humans; it will always be generated by mathematical software. Certainly in the beginning, we do not expect to receive much material in Content MathML from authors. Conversions from mathematical typesetting formats such as  $\text{T}_\text{E}_\text{X}$  will produce Presentation MathML. Therefore our articles will almost always contain Presentational MathML when they follow the regular workflow.

We do not exclude Content MathML. Applications downstream should in principle be prepared to receive and process both types of MathML.

The CEP 1.1 includes a version of MathML modified by Elsevier. Standard, the `mml:mtext` element can only contain `#PCDATA`, which is insufficient. Therefore we made sure that the content allows `%nondisplay.data` to be used. For instance, this allows us to make cross-references within a displayed formula.

MathML Plane One characters may not be used, `mathvariant` should be used instead.

## Usage of MathML elements and attributes

For backwards compatibility, version 2 of the MathML standard [24] contains a number of deprecated attributes, which were present in MathML version 1. These attributes must not be used in Elsevier articles and books. They are listed in the following pages. There is one exception: The `font*` attributes may be used in exceptional cases, see the subsection on ‘Style, fonts and mathvariants’.

The MathML standard covers many publication contexts, from articles in scientific journals to distant learning courses on the web. Consequently, some elements and attributes are more applicable to one publication context than to another. In the following pages we list the elements and attributes which are currently considered not to be applicable in the context of Elsevier articles and books. Such elements and attributes may not be used. It should be noted that understanding of this issue may evolve with time. For example, we do not see a role for the `mml:maction` element in current publications. With increasing understanding of the possibilities of MathML by both authors and web publishing platforms, suitable forms of usage of the `mml:maction` element may be identified in the years to come.

The following listing indicates which attributes are deprecated in MathML 2, and which elements and attributes may not be used in the context of Elsevier articles and books.

### Style, fonts and mathvariants

The MathML spec. [24] allows the CSS attribute `style` on all elements. In addition it allows the attributes `fontfamily`, `fontweight`, `fontstyle` and `mathvariant` on all token elements. Each of these attributes can be used to specify a different style for a variable. But these attributes convey different information about the variable, and therefore they cannot be used interchangeably.

The CSS (Cascading Style Sheet) attribute `style` indicates a style that is imposed by features that are external to the formula, and which has no influence on the interpretation of the formula. An example is the boldening of an inline formula in a bold header. Because such presentational markup may not be used in our articles, the attribute `style` must not be used.

It is a characteristic of mathematical notation that a style change for a single variable indicates a different meaning of the variable: a boldface  $A$  is a different variable than  $A$ . Such a style change may be achieved by the attribute `mathvariant`. The list of values of `mathvariant` is constrained, and the symbol in the desired style must exist as a mathematical styled character in Unicode, usually in Plane One.

If a symbol is desired in a style that is not an allowed value of the `mathvariant` attribute, or if a symbol in a desired style does not exist as a mathematical styled character in Unicode, it can currently not be used in that style. For example, it is not possible to have italic double-struck (open-face) characters, because italic double-struck is not an allowed value of the `mathvariant` attribute, and also because italic double-struck characters do not exist as mathematical styled characters in Unicode.

In the future we may allow the possibility to mark a symbol up using the attributes `fontfamily`, `fontweight` and `fontstyle`. The value of the attribute `fontfamily` should be one of a list of recognized font families. Currently there are no recognized font families,

and therefore this feature is not available. We will add fonts to the list when they are required in publications. The main candidates seem to be open-face (double-struck) fonts, for which DTD 4.x allowed more styles than MathML. It should be noted, however, that such symbols may not easily be rendered on each reader's computer; therefore this feature should be used only in exceptional cases.

The MathML spec. [24, section 3.2.2.1] excludes the combined usage of the `font*` attributes and the `mathvariant` attribute.

It is not allowed to use the font changing elements from the CEP to mark up a variable in MathML, not even in the `mml:mtext` element. Of course, font changing elements from the CEP are allowed to mark up an in-line formula that is tagged without MathML.

### All elements

The attribute `other` is deprecated, and must not be used. The attributes `xlink:href`, `xlink:type`, `style` must not be used.

### Token elements

The attributes `color` and `fontsize` are deprecated, and must not be used. The attributes `mathsize`, `mathcolor`, and `mathbackground` must not be used.

The attributes `fontfamily`, `fontweight` and `fontstyle` should only be used in exceptional cases, see the subsection on 'Style, fonts and mathvariants'.

### Individual elements

#### *mml:math*

The attribute `mode` is deprecated and must not be used. The attributes `macros`, `overflow`, `alttext` and `xsi:schemaLocation` must not be used.

The attributes `type`, `name`, `height`, `width` and `baseline` must not be used.

#### *mml:mo*

The true values of the attributes `fence`, `separator`, `accent` and `largeop` are mutually exclusive.

When the attribute `fence` has the value true, the `form` attribute may only have the values `prefix` or `postfix`.

When the attribute `accent` has the value true, the `form` attribute may only have the value `postfix`.

When the attribute `largeop` has the value true, the `form` attribute may only have the value `prefix`.

The attributes `symmetric`, `maxsize` and `minsize` only make sense when the attribute `stretchy` has the value true.

#### *mml:mglyph*

The element `mml:mglyph` should only be used in exceptional cases. The value of the attribute `fontfamily` must be taken from a list of allowed values; currently that list is empty.

#### *mml:mstyle*

The `mml:mstyle` element is used to make style changes that affect the rendering of its contents. `mml:mstyle` can be given any attribute accepted by any MathML presentation

element provided that the attribute value is inherited, computed or has a default value (MathML spec. [24, section 3.3.4.1]). For such attributes the rules apply that are mentioned with the individual elements.

In addition, there are a number of attributes which may only be specified on the `mml:mstyle` element: `background`, `scriptsizemultiplier`, `scriptminsize`, `veryverythinmathspace`, `verythinmathspace`, `thinmathspace`, `mediummathspace`, `thickmathspace`, `verythickmathspace`, `veryverythickmathspace`. None of these attributes is allowed to be used.

*mml:mtext*

The attributes `mathvariant`, `fontweight`, `fontstyle`, `fontfamily` must not be used. Instead, the element `mml:mtext` has been modified to allow CEP inline markup.

*mml:merror*

The `mml:merror` element must not be used.

*mml:maction*

The `mml:maction` element must not be used.

## mml:math

### Declaration

#### Model

```

<!ELEMENT math
( mi | mn | mo | mtext | ms | mspace
  | mrow | mfrac | msqrt | mroot
  | menclose | mstyle | merror
  | mpadded | mphantom | mfenced
  | msub | msup | msubsup | munder
  | mover | munderover | mmultiscripts
  | mtable | mtr | mlabeledtr | mtd
  | maligngroup | malignmark | maction
  | %ContInPres; )>

<!ATTLIST math
  xmlns:mml          CDATA          #FIXED
                    http://www.w3.org/1998/Math/MathML
  xlink:href         CDATA          #IMPLIED
  xlink:type        CDATA          #IMPLIED
  class              CDATA          #IMPLIED
  style              CDATA          #IMPLIED
  id                 ID             #IMPLIED
  xref               IDREF          #IMPLIED
  other              CDATA          #IMPLIED
  macros             CDATA          #IMPLIED
  mode               CDATA          #IMPLIED
  display            CDATA          #IMPLIED
  type               CDATA          #IMPLIED
  name               CDATA          #IMPLIED
  height             CDATA          #IMPLIED
  width              CDATA          #IMPLIED
  baseline           CDATA          #IMPLIED
  overflow           (scroll|elide|truncate|scale)  'scroll'
  altimg             CDATA          #IMPLIED
  alttext            CDATA          #IMPLIED>

```

### Description

The element `mml:math` contains a MathML formula.

### Usage

The `mml:math` element, which can be used inline and within `ce:formula`, is used to capture mathematical formulae. It is an element belonging to MathML, and we refer to MathML documentation for details. It is well-known that parsing MathML is not sufficient for a file to conform to the MathML specifications.

`mml:math` must never be nested within `mml:math`.

Each `mml:math` is delivered together with a graphical representation for rendering applications that cannot handle MathML. Such an image is called a *strip-in*. The attribute `altimg` contains the name of the strip-in image, it is a file name inclusive extension, see the section on [strip-in images](#) (p. 30).

The attribute `mode` is deprecated, and should not be used. The attributes `style`, `macros`, `overflow`, and `alttext` should not be used.

mml:math

Chapter 9 – MathML

### See also

[ce:enunciation](#), [ce:formula](#), [ce:italic](#)

## Chapter 10

# (Extended) CALS tables

Over the course of the years contractors of the US Department of Defense converged to a single table model, the so-called CALS Table Model (Computer-Aided Logistics Support). It became a *de facto* standard, which was used by many and supported by many software packages. OASIS published documentation of the full CALS table elements and attributes [13], in order to promote a shared interpretation. It has also critically reviewed the CALS table model and the software support for it. The result is the OASIS Exchange Model [15].

In the DTD 5.0 family, Elsevier has adopted CALS tables according to this OASIS Exchange Model. The parametrization was exploited to make `%cell.data`; the content of a table cell and to furnish the tables with a label, a caption, a legend and table footnotes. However, as became apparent, even with the extensive parametrization options, the CALS table model was not sufficient for our needs. This is why we extended the CALS tables with the border elements from earlier Elsevier DTDs and with a modified element for column specifications. These additional elements are placed in their own namespace, `http://www.elsevier.com/xml/common/table/dtd`, which can be recognized by the `tb:` prefix.

A CALS table is not necessarily valid if it satisfies the DTD. The description of `entry` in the CALS specification [15] summarizes conditions which make a CALS table invalid. These error conditions translate into the following requirements:

- A column name used in a `colname`, `namest` or `nameend` attribute must be a `colname` declared in a `colspec` or a `tb:colspec` in the containing `tgroup`.
- The names declared in different `colspecs` and `tb:colspecs` of a `tgroup` must be different.
- It is an error if portions of different `entry`s overlap each other.
- It is an error if an `entry`'s `morerows` attribute specifies more additional rows than the number of remaining rows defined for the containing `thead` or `tbody`.
- It is an error if the number of columns filled by the `entry`s in a row, taking column spanning by `entry`s in that row, and row spanning by `entry`s in previous rows into account, exceeds the value of the `cols` attribute of the containing `tgroup`.
- The column specified by the `nameend` attribute of an `entry` must be to the right of (i.e. have a higher column number than) the column specified by the `namest` attribute of the `entry`.

Note. The `morerows` attribute denotes the number of *additional* rows spanned. In this respect it differs from the attribute `rspan` of DTD 4 and the attribute `rowspan` of HTML:  $morerows = rspan - 1$ .

Note. `entry` elements which span more rows require special attention. They fill columns in their own row and in one or more following rows. The following rows have no `entry`

elements for those columns. It is not necessary nor allowed to place empty `entry` elements in those rows as placeholders.

The CALS table specification allows some fairly complicated constructions using column names. Elsevier wants to avoid such complications. Elsevier wants to ensure that its CALS tables have a regular and straightforward structure, and are easily transformed into display formats. This can be summarized in the following requirements. These requirements are additional to the standard CALS requirements listed above.

- An `entry` may not have both a `namest` attribute and a `colname` attribute.
- If an `entry` has a `nameend` attribute, it must also have a `namest` attribute.
- The `colspecs` and `tb:colspecs` must be listed in column order.
- There must be a `colspec` or `tb:colspec` for every column, up to the number of columns declared in the `cols` attribute of the containing `tgroup`.
- It is an error if there is a `colspec` or `tb:colspec` for a column whose number is higher than the number of columns declared in the `cols` attribute of the containing `tgroup`.
- The column names declared in the `colspec` or `tb:colspec` elements must adhere to the pattern: “col” followed by the column number, i.e. “colN”.
- The `entries` in a row must be listed in column order, taking into account that `entries` which are straddled by row spanning `entries` in previous rows, should be skipped.
- All `entries` in a row must be listed, taking into account that `entries` which are straddled by row spanning `entries` in previous rows, should be skipped.

The latter two rules are almost identical to the requirements for cells in DTD 4. The difference is that no `entries` are listed which are spanned by other `entries`.

This chapter contains a listing of the elements of the extended CALS table model. We first give a number of examples of CALS tables. After a brief overview of the native CALS elements (for more information, we refer to [1] and [15]) we list the CALS table extensions.

A table containing at least one element from the `tb` namespace is called an *extended CALS table*. Tables without these extensions are called *native CALS tables*.

It is only allowed to create an extended CALS table if a native CALS table cannot be used to represent the table. The examples in the [next section](#) show and explain the cases when this is appropriate. In the following cases an extended CALS table is inevitable:

- when the alignment in cells requires vertical alignmarks, `tb:alignmark`;
- when the border style is an “ornament” (see the [ornament tables](#), p. 471), other than a single vertical or horizontal line;
- when the cell borders at the outer extremities of the table require a different border style than the table frame (the frame cannot be overruled);
- when cells need a top border but the cell above spans different columns;
- when cells need a left border but the cell to the left spans different rows.

### Bridge lines

Spanning lines or bridge lines spanning a number of columns in the head of a table are created by setting the `rowsep` of the cell above the spanned columns. We define that the `rowseps` of different cells within the interior of the head never touch. This is similar to the definition in DTD 4.x.



### Inheritance of attribute values

The CALS table model does not use default attribute values in the strict sense, that is, default values that are specified in the DTD, and that are reported by a parser. Instead, it uses the absence of an attribute value to signal that the value should be inherited from a specified other element, usually the parent element, or that it has a default value. The CALS specification mentions the possibility to specify default values in style sheets. That possibility is not used in Elsevier's XML files; the default values are those listed in the CALS specification.

The inheritance paths and default values are as follows:

attribute	inheritance path	default
<code>valign</code>	<code>entry</code> → <code>row</code> → $\begin{cases} \text{thead} \\ \text{tbody} \end{cases}$	bottom top
<code>align</code>	<code>entry</code> → <code>colspec</code> → <code>tgroup</code>	left
<code>char</code>	<code>entry</code> → <code>colspec</code> → <code>tgroup</code>	–
<code>charoff</code>	<code>entry</code> → <code>colspec</code> → <code>tgroup</code>	50%
<code>rowsep</code>	<code>entry</code> → <code>row</code> → <code>colspec</code> → <code>tgroup</code> → <code>ce:table</code>	1
<code>colsep</code>	<code>entry</code> → <code>colspec</code> → <code>tgroup</code> → <code>ce:table</code>	1

In this scheme, each → means: if the attribute value is not specified for the element on the left, use the value from the element on the right. Each occurrence of `colspec` should be read as `colspec` or `tb:colspec`.

## CALS tables — Examples

### Example 1

The following table is a standard CALS table except for column 6. Column 6 uses an `alignmark`, which is not available in standard CALS. The fact that this column uses an extension to the standard CALS table model is signalled by the presence of the `tb` prefix on the `tb:colspec` and `tb:alignmark` elements.

*XML*

```
<ce:table id="tbl001" frame="topbot" colsep="0" rowsep="0">
  <ce:label>Table 1</ce:label>
  <ce:caption>
    <ce:simple-para>Sm-Nd data.</ce:simple-para>
  </ce:caption>
  <tgroup cols="6">
    <colspec colname="col1"/>
    <colspec colname="col2"/>
    <colspec colname="col3"/>
    <colspec colname="col4"/>
    <colspec colname="col5"/>
    <tb:colspec colname="col6"/>
    <thead>
      <row valign="top" rowsep="1">
        <entry namest="col1" nameend="col2">Eclogites</entry>
        <entry>Sm</entry>
        <entry>Nd</entry>
        <entry><ce:sup loc="pre">147</ce:sup>Sm
          / <ce:sup loc="pre">144</ce:sup>Nd</entry>
        <entry>Yield (%)</entry>
      </row>
    </thead>
    <tbody>
      <row valign="top">
        <entry>162a</entry>
        <entry>Grenat</entry>
        <entry align="char" char=".">0.92</entry>
        <entry align="char" char=".">2.31</entry>
        <entry align="char" char="+">0.240 + 0.005</entry>
        <entry>10.512 <tb:alignmark/>+ 10.000 <tb:alignmark/>&minus; 0.500</entry>
      </row>
      <row valign="top">
        <entry/>
        <entry>Omphacite</entry>
        <entry align="char" char=".">6.41</entry>
        <entry align="char" char=".">23.60</entry>
        <entry align="char" char="+">0.164 + 0.04</entry>
        <entry>10.51 <tb:alignmark/>+ 10.05 <tb:alignmark/>&minus; 0.05</entry>
      </row>
    </tbody>
  </tgroup>
</ce:table>
```

*Presentation*

Table 1

Sm-Nd data.

Eclogites		Sm	Nd	$^{147}\text{Nd}/^{144}\text{Nd}$	$^{143}\text{Nd}/^{144}\text{Nd}$
162a	Grenat	0.92	2.31	0.240 + 0.005	10.512 + 10.000 - 0.500
	Omphacite	6.41	23.60	0.164 + 0.04	10.51 + 10.05 - 0.05

**Explanation**

The horizontal rules at the top and bottom of the table are specified by the value `topbot` of the `frame` attribute of the `ce:table` element.

The default value of the `colsep` and `rowsep` attributes of the `ce:table` element is implied, which according to the CALS documentation means that there are row and column separators for each row and column unless specified otherwise for a certain row, column or entry. Here we specify the value 0 for these attributes, which means that in this table we have no row and column specifiers unless specified otherwise for a certain row, column or entry.

The table has a single `tgroup` element, with a `thead` containing one row and a `tbody` containing 2 rows.

The `tgroup` starts with five `colspec` elements. They have no `colnum` attribute, and thus are automatically assigned to columns 1 to 5. They *do* specify a name for the column, in the `colname` attribute. This name is used below to specify column spanning.

The sixth element is a `tb:colspec` element. This indicates automatically that the column uses alignment markers `tb:alignmark`, due to the default value `mark` of its `align` attribute.

In principle the `colspec` elements for columns 3 to 5 could have been omitted, because we do not make use of them, and the `tb:colspec` element for column sixth could have specified that it applies to column 6, by the value of its `colnum` attribute. However, skipping `colspec` elements is less desirable because it is not supported by all CALS table applications.

The first `entry` of the first `row` spans two columns. This is indicated by the values of the `namest` and `nameend` attributes, which are the names of the starting and ending columns.

The other entries in this row override the alignment specified for the column by having their own `align` attributes.

The rule between the table head and the table body must be specified explicitly. This is done by the value 1 of the `rowsep` attribute of the `row`.

The fifth entries in the two rows in the `tbody` demonstrate that alignment may be specified on any character: these entries align on the ‘+’ character.

The last entries use two alignment markers `tb:alignmark` to align on the + and – signs in the entry. Note that an alignment marker may introduce space to its left (see the example in the discussion of the `tb:alignmark` element). An earlier version of this example ignored that fact and was therefore in error.

This column alignment mechanism has a superficial similarity with the alignment mechanism using alignment markers and alignment groups in MathML; see Section 3.5.5 of the

MathML specification. The latter, however, is more complicated and more powerful, due to its usage of alignment groups.

Finally note that `entry` has mixed content. Therefore, if one would insert a linebreak after the start tag, one would insert a space at the start of the entry's content. Similarly for a line break before the end tag. This would be undesirable.

## Example 2

The following table demonstrates our requirements for regular tables.

- For each column a `colspec` element is present, and the `colspec` elements are listed in column order.
- All `entry` elements of a row are listed, in column order. Only a series of empty `entry` elements at the end of the row has been omitted.

Rows 4 and 5 demonstrate entries which span more than one row. Entries 1–3 of row 4 extend into row 5 and fill columns 1–3 in that row as well. In row 5 there are no entries for columns 1–3; the first listed (empty) entry automatically falls in column 4.

*XML*

```
<ce:table id="tbl1" frame="all">
  <tgroup cols="5">
    <colspec colnum="1" colname="col1"/>
    <colspec colnum="2" colname="col2"/>
    <colspec colnum="3" colname="col3"/>
    <colspec colnum="4" colname="col4"/>
    <colspec colnum="5" colname="col5"/>
  <tbody>
    <row>
      <entry>A</entry>
      <entry>B</entry>
      <entry>C</entry>
      <entry>D</entry>
      <entry>E</entry>
    </row>
    <row>
      <entry/>
      <entry/>
      <entry>C</entry>
    </row>
    <row>
      <entry/>
      <entry namest="col2" nameend="col4">BCD</entry>
      <entry>E</entry>
    </row>
    <row>
      <entry namest="col1" nameend="col3" morerows="1">ABCABC</entry>
      <entry>D</entry>
    </row>
    <row>
      <!--NO ENTRY-->
      <!--NO ENTRY-->
      <!--NO ENTRY-->
      <entry/>
      <entry>E</entry>
  </tbody>
</ce:table>
```

```

    </row>
  </tbody>
</tgroup>
</ce:table>

```

*Presentation*

A	B	C	D	E
		C		
	BCD			E
ABCABC			D	
				E

**Example 3**

The following table is a standard CALS table except for one row. The cells in this row specify a left border, a top border and a right border, which are not available in standard CALS. The fact that this row uses an extension to the standard CALS table model is signalled by the presence of the `tb` prefix on the `tb:left-border`, `tb:top-border` and `tb:right-border` elements.

*XML*

```

<ce:table id="tbl1" frame="topbot" colsep="0" rowsep="0">
  <ce:label>Table 1</ce:label>
  <ce:caption>
    <ce:simple-para id="sp1">Colours</ce:simple-para>
  </ce:caption>
  <ce:link locator="tbl1"/>
  <tgroup cols="3">
    <colspec colnum="1" colname="col1" colwidth="3*"/>
    <colspec colnum="2" colname="col2" colwidth="2*"/>
    <colspec colnum="3" colname="col3" colwidth="4*"/>
    <thead>
      <row rowsep="1">
        <entry>Colour 1</entry>
        <entry>Colour 2</entry>
        <entry>Colour 3</entry>
      </row>
    </thead>
    <tbody>
      <row>
        <entry>Red</entry>
        <entry>Green</entry>
        <entry>Blue</entry>
      </row>
      <row>
        <entry namest="col1" nameend="col3">White<ce:cross-ref
          refid="tblfn1"><ce:sup>a</ce:sup></ce:cross-ref></entry>
      </row>
      <row>
        <entry colsep="1"><tb:left-border/>Blue</entry>
        <entry morerows="1" colsep="1"><tb:top-border/>High
          Green</entry>
        <entry><tb:right-border/>Red</entry>
      </row>
    </tbody>
  </tgroup>
</ce:table>

```

```

<row>
  <entry colsep="1" colname="col1">Red</entry>
  <!--NO ENTRY-->
  <entry>Blue</entry>
</row>
</tbody>
</tgroup>
<ce:legend>
  <ce:simple-para>The colours in this table are shown in various cell
entry layouts. These layouts demonstrate the various possibilities of
CALS tables and of the extensions to CALS tables.</ce:simple-para>
</ce:legend>
<ce:table-footnote id="tblfn1">
  <ce:label>a</ce:label>
  <ce:note-para>White is obtained by applying an equal mixture of
Red, Green and Blue.</ce:note-para>
</ce:table-footnote>
</ce:table>

```

*Presentation*

The table below is a not-to-scale rendition of the table tagged above. The thick lines denote “real” lines, the thin lines indicate cell borders without border lines. The dotted oblong represents an included image.

Table 1  
Colours

Image tbl1		
Colour 1	Colour 2	Colour 3
Red	Green	Blue
White <sup>a</sup>		
Blue	High Green	Red
Red		Blue

The colour names in this table are shown in various cell entry layouts. These layouts demonstrate the various possibilities of CALS tables and of the extensions to CALS tables.

<sup>a</sup> White is obtained by applying an equal mixture of Red, Green and Blue.

**Explanation**

A table may contain a mixture of `tgroup` elements and `ce:link` elements. The `ce:link` elements stand for table groups which have been captured as an image. In this example the

table opens with a `ce:link` element. Note that the image should contain the bottom border of that part of the table if there is any.

The `colspec` elements of the `tgroup` specify the relative widths of the columns. A ‘\*’ denotes the unit width. The column widths are expressed as multiples of this unit width. Since decimal values are not supported by any software, the proportional width values should be *integer*. The actual value of the unit width is determined at rendering time. The `colspec` elements also specify names for the columns, to be used to specify column spanning.

The entry in the second row spans three columns, which is indicated by the values of the `namest` and `nameend` attributes, which are the names of the starting and ending columns.

The next row starts with an entry with a left border. Use of the extension element `tb:left-border` is the only way to achieve that.

The same row contains an entry (“High Green”) that spans two rows and is framed. The row spanning is indicated by the value of the `morerows` attribute of the `entry` element. Its left border is specified by the value of the `colsep` attribute of the two entries to the left. Its bottom border coincides with the bottom frame of the table, and need not be specified. Its top border would have been specified by the value of the `rowsep` attribute of the entry above were it not the case that the entry above spans different columns. The border of the cell above would span the same three columns, more than the top of the “High Green” cell. Therefore the only option is to use an extended CALS element, the top-border element.

The same row ends with an entry with a right border. Here using the `rowsep` attribute would not be correct, because the `colsep` and `rowsep` attributes on the outer borders of the table are overruled by the `frame` attribute of the `ce:table`. Use of the extension element `tb:right-border` is the only valid way to specify this right border.

In the last row the second entry is omitted, because its space is occupied by the entry from the row above. The table processing software should know this and move the entry count forward by 1.

#### Example 4

XML

```
<ce:table colsep="0" rowsep="0" id="tbl3" frame="topbot">
  <ce:label>Table 3</ce:label>
  <ce:caption>
    <ce:simple-para>Efficacy of Clinical Staging</ce:simple-para>
  </ce:caption>
  <tgroup cols="5">
    <colspec colname="col1"/>
    <colspec colname="col2"/>
    <colspec colname="col3"/>
    <colspec colname="col4"/>
    <colspec colname="col5"/>
  <thead>
    <row>
      <entry morerows="1" align="center" rowsep="1">Stage</entry>
      <entry namest="col2" nameend="col3" align="center"
        rowsep="1">Positive Predictive Value</entry>
      <entry namest="col4" nameend="col5" align="center"
        rowsep="1">Sensitivity</entry>
    </row>
```

```

<row rowsep="1">
  <entry align="center">FDG-PET/CT (%)</entry>
  <entry align="center">CT (%)</entry>
  <entry align="center">FDG-PET/CT (%)</entry>
  <entry align="center">CT (%)</entry>
</row>
</thead>
<tbody valign="top">
  <row>
    <entry>I</entry>
    <entry>58</entry>
    <entry>62</entry>
    <entry>44</entry>
    <entry>49</entry>
  </row>
</tbody>
</tgroup>
</ce:table>

```

*Presentation*

Table 3  
Efficacy of Clinical Staging

Stage	Positive Predictive Value		Sensitivity	
	FDG-PET/CT (%)	CT (%)	FDG-PET/CT (%)	CT (%)
I	58	62	44	49

**Explanation**

The first row of the table head has two entries which each span two columns. Both entries have a rowsep value of 1, that is, they have a row separator at their bottom. Normally, because the entries are in adjacent columns, their row separators would join to create a rule from column 2 up to column 5.

Because Elsevier tables do use spanning lines or bridge lines and do not use row separators in the table head, we use the row separators in the interior of the table head to create bridge lines. Therefore we define that the rowseps of different cells within the interior of the head never touch.

As a consequence, the row separators of the second and third entry in the first row of the table head do *not* touch each other. This is similar to the definition in DTD 4.x.

The definition does not extend to the rule at the bottom of the table head. The row separators of the entry with the text ‘Stage’ and of the four entries in the second row of the table head join to form a continuous rule across the table.

The value of the `rowsep` attribute on the `row` element sets the default value of the `rowsep` attribute for the `entry` elements in the row. Setting `<row rowsep="1">` is equivalent to setting `<entry rowsep="1">` for all entries in that row. Therefore the following tagging produces the same result as the above example.

*XML*

```

...
<thead>
  <row rowsep="1">
    <entry morerows="1" align="center">Stage</entry>

```



```
<entry namest="col2" nameend="col3"
  align="center">Positive Predictive Value</entry>
<entry namest="col4" nameend="col5"
  align="center">Sensitivity</entry>
</row>
<row rowsep="1">
  <entry align="center">FDG-PET/CT (%)</entry>
  <entry align="center">CT (%)</entry>
  <entry align="center">FDG-PET/CT (%)</entry>
  <entry align="center">CT (%)</entry>
</row>
</thead>
...
```

## CALS table elements

This section lists the table elements from the OASIS Exchange Table Model DTD [15]. For precise descriptions about these elements and their extensive attribute lists, we refer to the literature about the CALS tables, e.g. [1].

These elements have no namespace prefix. They belong to the CALS namespace, `http://www.elsevier.com/xml/common/cals/dtd`, due to the `xmlns` attribute of the element `ce:table`. The element `entry` is an exception: it belongs to the common element pool's namespace.

### colspec

#### Model

<!ELEMENT	colspec	EMPTY>	
<!ATTLIST	colspec		
	colnum	NMTOKEN	#IMPLIED
	colname	NMTOKEN	#IMPLIED
	colwidth	CDATA	#IMPLIED
	colsep	<code>%yesorno;</code>	#IMPLIED
	rowsep	<code>%yesorno;</code>	#IMPLIED
	align	(left right center justify char)	#IMPLIED
	char	CDATA	#IMPLIED
	charoff	NMTOKEN	#IMPLIED>

The element `colspec` defines a column specification, in which each column can be given a name, width, alignment, and a right-hand separator. The element `tb:colspec` is provided as an alternative, which then results in an extended CALS table.

### entry

#### Model

<!ELEMENT	entry	( <code>%cell.data;</code> )>	
<!ATTLIST	entry		
	colname	NMTOKEN	#IMPLIED
	namest	NMTOKEN	#IMPLIED
	nameend	NMTOKEN	#IMPLIED
	morerows	NMTOKEN	#IMPLIED
	colsep	<code>%yesorno;</code>	#IMPLIED
	rowsep	<code>%yesorno;</code>	#IMPLIED
	align	(left right center justify char)	#IMPLIED
	char	CDATA	#IMPLIED
	charoff	NMTOKEN	#IMPLIED
	valign	(top middle bottom)	#IMPLIED
	id	ID	#IMPLIED
	role	CDATA	#IMPLIED
	xmlns	CDATA	#FIXED <code>%ESCE.xmlns;</code> >

The element `entry` defines a cell in the table, which may or may not span more than one row or column. The default alignment and separator below and to the right, defined in

the column specification, on the row or on the table, can be overridden. The content of this element is `%cell.data`, i.e. contains elements from the common element pool, as well as the border elements `tb:bottom-border`, `tb:left-border`, `tb:right-border`, `tb:top-border`, and the vertical mark `tb:alignmark`. When these elements from the extended table namespace are present in the cell, the table becomes an extended CALS table.

`entry` is the only element in the namespace of the common element pool that has no prefix.

## row

### Model

```
<!ELEMENT row ( entry+ )>
<!ATTLIST row
  rowsep %yesorno; #IMPLIED
  valign (top|middle|bottom)
          #IMPLIED
  id ID #IMPLIED
  role CDATA #IMPLIED>
```

The element `row` defines a row in the table, consisting of table entries. It has attributes to define the alignment and separator below the row.

## tbody

### Model

```
<!ELEMENT tbody ( row+ )>
<!ATTLIST tbody
  valign (top|middle|bottom)
          #IMPLIED>
```

The element `tbody` contains the body of the table, i.e. the rectangular structure of rows and columns.

## tgroup

### Model

```
<!ELEMENT tgroup ( ( colspec | tb:colspec )* , thead?,
  tbody )>
<!ATTLIST tgroup
  cols NMTOKEN #REQUIRED
  colsep %yesorno; #IMPLIED
  rowsep %yesorno; #IMPLIED
  align (left|right|center|justify|char)
         #IMPLIED
  altimg CDATA #REQUIRED>
```

The element `tgroup` contains the structure of the table: a column specification, an optional head and a body. Note that a table foot, while present in some CALS table models, is not available in the OASIS Exchange Table Model DTD.

The `tgroup` has an additional `altimg` attribute. This attribute contains a reference to a graphic file containing an image of the `tgroup`. It is present for extended CALS tables.

Such a graphic representation of the table is called a *strip-in*. See the section on [strip-in images](#) (p. 30).

## thead

### Model

```
<!ELEMENT  thead          ( row+ )>
<!ATTLIST  thead
           valign          (top|middle|bottom)
                               #IMPLIED>
```

The element [thead](#) contains the header rows of the table. These rows are repeated when the table is split over several pages. Prior to DTD 5.0, header rows were defined as “stubs”.

## tb:alignmark

### Declaration

#### Model (CEPs 1.1.0–1.1.6)

```
<!ELEMENT tb:alignmark EMPTY>
```

### Description

The element `tb:alignmark` is a vertical mark. It can be used to obtain complicated alignments within table cells. However, using this element takes the table outside of the scope of CALS tables.

### Usage

A vertical alignment mark, `tb:alignmark`, is an empty element which can occur within a table cell, `entry`. If any border elements are present within the cell, they must precede the `tb:alignmark`.

If the alignment of a column is not specified by a `tb:colspec` element, then the vertical alignment mark is forbidden in the cells of that column. Otherwise, the *i*th `tb:alignmark` of the *n*th cell in a row, must be left-aligned with the *i*th `tb:alignmark` in all *n*th cells of the rows in the same `tbody`. This rule is independent of the span of a cell, i.e., in a spanned cell it is only possible to align with alignment points in the leftmost spanned column.

In a column the numbers of `tb:alignmarks` per cell need not be equal. The rules still apply when this is the case.

#### XML

```
<tgroup cols="1">
  <tb:colspec/>
  <tbody>
    <row>
      <entry>a<tb:alignmark/>bcd<tb:alignmark/>e</entry>
    </row>
    <row>
      <entry>pq<tb:alignmark/>r<tb:alignmark/>stu</entry>
    </row>
  </tbody>
</tgroup>
```

#### Presentation

```
a bcd
pqr  stu
```

### See also

`tb:colspec`. More details are given in the [examples section](#) (p. 454).

## tb:bottom-border

### Declaration

#### Model (CEPs 1.1.0–1.1.6)

```
<!ELEMENT  tb:bottom-border      EMPTY>
<!ATTLIST  tb:bottom-border
           type                %hline;      'bar'
           style               %style;      's'>
```

### Description

The element [tb:bottom-border](#), when present in a cell, provides the cell with a bottom border.

### Usage

[tb:bottom-border](#) is an empty element, which may appear within a cell [entry](#) of a table. When it is present in a cell, it provides the cell with a bottom border.

Two attributes, [type](#) (default `bar`) and [style](#) (default: `single, s`), determine what the border will look like. See [Tables 7, 9 and 10](#) (pp. [471–472](#)) for the allowed combinations of values of these attributes.

Border elements must come before any other content of the [entry](#).

### See also

More details can be found in the [examples section](#) (p. [454](#)).

## tb:colspec

### Declaration

#### Model (CEPs 1.1.0–1.1.6)

```

<!ELEMENT  tb:colspec          EMPTY>
<!ATTLIST  tb:colspec
  colnum          NMTOKEN          #IMPLIED
  colname         NMTOKEN          #IMPLIED
  colwidth       CDATA            #IMPLIED
  colsep         %yesorno;        #IMPLIED
  rowsep         %yesorno;        #IMPLIED
  align          ( mark )        #FIXED 'mark'>

```

### Description

A [tb:colspec](#) element must be used instead of a [colspec](#) element to specify a column that uses alignment on [tb:alignmark](#) elements.

### Usage

A [tb:colspec](#) element is used in the same way as a [colspec](#) element, except that its [align](#) attribute has the fixed value `mark`.

### Version history

Prior to DTD 5.0, vertical alignment along marks was specified with the value `vmk` of the `ca` attribute of the `c` element.

### See also

For an example see [tb:alignmark](#). More details can be found in the [examples section](#) (p. 454).

## tb:left-border

### Declaration

#### Model (CEPs 1.1.0–1.1.6)

```
<!ELEMENT  tb:left-border      EMPTY>
<!ATTLIST  tb:left-border
            type                %vline;      'vb'
            style               %style;      's'>
```

### Description

The element `tb:left-border`, when present in a cell, provides the cell with a left border.

### Usage

`tb:left-border` is an empty element, which may appear within a cell `entry` of a table. When it is present in a cell, it provides the cell with a left border.

Two attributes, `type` (default `vb`) and `style` (default: `single, s`), determine what the border will look like. See Tables 8, 9 and 10 (pp. 471–472) for the allowed combinations of values of these attributes.

Border elements must come before any other content of the `entry`.

### See also

More details can be found in the [examples section](#) (p. 454).



## tb:right-border

### Declaration

#### Model (CEPs 1.1.0–1.1.6)

```
<!ELEMENT  tb:right-border      EMPTY>
<!ATTLIST  tb:right-border
           type                %vline;      'vb'
           style               %style;      's'>
```

### Description

The element `tb:right-border`, when present in a cell, provides the cell with a right border.

### Usage

`tb:right-border` is an empty element, which may appear within a cell `entry` of a table or an array. When it is present in a cell, it provides the cell with a right border.

Two attributes, `type` (default `vb`) and `style` (default: `single, s`), determine what the border will look like. See Tables 8, 9 and 10 (pp. 471–472) for the allowed combinations of values of these attributes.

Border elements must come before any other content of the `entry`.

### See also

More details can be found in the [examples section](#) (p. 454).

## tb:top-border

### Declaration

#### Model (CEPs 1.1.0–1.1.6)

```
<!ELEMENT  tb:top-border      EMPTY>
<!ATTLIST  tb:top-border
           type                %hline;      'bar'
           style               %style;      's'>
```

### Description

The element [tb:top-border](#), when present in a cell, provides the cell with a top border.

### Usage

[tb:top-border](#) is an empty element, which may appear within a cell [entry](#) of a table or an array. When it is present in a cell, it provides the cell with a top border.

Two attributes, [type](#) (default `bar`) and [style](#) (default: `single`, `s`), determine what the border will look like. See Tables [7](#), [9](#) and [10](#) (pp. [471–472](#)) for the allowed combinations of values of these attributes.

Border elements must come before any other content of the [entry](#).

### See also

More details can be found in the [examples section](#) (p. [454](#)).

## Ornament types and styles

Several elements have `type` and `style` attributes, defining an *ornament*. The attribute values and the allowed combinations are described in this section.

Table 7: Valid values (`%hline;`) of the `type` attribute of elements that specify a horizontal line or other ornament. These occur in `tb:bottom-border` and `tb:top-border`.

Attribute value	Symbol	Attribute value	Symbol
<code>bar</code>	—	<code>circ</code>	⤿
<code>tcub</code>	⏞	<code>tilde</code>	⤿
<code>bcub</code>	⏟	<code>rarr</code>	→
<code>tsqb</code>	⌈	<code>larr</code>	←
<code>bsqb</code>	⌋	<code>harr</code>	↔
<code>tpar</code>	(	<code>lharu</code>	↙
<code>bpar</code>	)	<code>rharu</code>	↘

Table 8: Legal values (`%vline;`) of the `type` attribute of elements that specify a vertical line or other ornament. These may occur in `tb:left-border` and `tb:right-border`.

Attribute value	Symbol	Attribute value	Symbol
<code>lpar</code>	(	<code>bsol</code>	\
<code>rpar</code>	)	<code>lceil</code>	⌈
<code>lsqb</code>	[	<code>rceil</code>	⌋
<code>rsqb</code>	]	<code>lfloor</code>	⌊
<code>lcub</code>	{	<code>rfloor</code>	⌋
<code>rcub</code>	}	<code>dharr</code>	⤵
<code>vb</code>		<code>uharr</code>	⤴
<code>lang</code>	<	<code>darr</code>	↓
<code>rang</code>	>	<code>uarr</code>	↑
<code>sol</code>	/	<code>varr</code>	↕

Table 9: Values (`%style;`) of the `style` attribute. It may occur in `tb:bottom-border`, `tb:left-border`, `tb:right-border` and `tb:top-border`.

Value	Meaning	Example
<code>s</code>	single	
<code>d</code>	double	
<code>t</code>	triple	
<code>da</code>	dashed	⋯
<code>dot</code>	dotted	⋯
<code>b</code>	bold	⦿
<code>bl</code>	blank	space between
<code>n</code>	none	no space between

Table 10: Valid combinations of type (`%hline;`, `%vline;`) and style (`%style;`) attributes.

type	style							
	s	d	t	da	dot	b	bl	n
<code>lpar</code> (	×	×				×	×	
<code>rpar</code> )	×	×				×	×	
<code>lsqb</code> [	×	×				×	×	
<code>rsqb</code> ]	×	×				×	×	
<code>vb</code>	×	×	×	×	×	×	×	×
<code>lang</code> <	×	×				×	×	
<code>rang</code> >	×	×				×	×	
<code>bar</code> —	×	×	×	×	×	×	×	×

All other horizontal and vertical types may only occur in combination with s, b or bl.

# Bibliography

- [1] N. Bradley, *The Concise SGML Companion* (Addison Wesley, 1996), <http://www.bradley.co.uk/sgmlbook.html>.
- [2] D.C. Coleman, J. Friederich, N.A.F.M. Poppelier and F.K. Veldmeijer, The design of an SGML document type definition for scientific articles, Internal report, Elsevier Science B.V., 14 October 1992.
- [3] M. Bryan, *SGML, An Author's Guide to the Standard Generalized Markup Language* (Addison-Wesley Publishing Company, 1988).
- [4] C. Goldfarb, *The SGML Handbook* (Oxford University Press, 1990).
- [5] S. Pepping and R. Schrauwen, *Tag by Tag, The Elsevier Science Full-Length Article DTDs 4.1–4.3* (March 2001) <http://www.elsevier.com/locate/sgml>.
- [6] G.K. Pullum and W.A. Ladusaw, *Phonetic Symbol Guide* (University of Chicago Press, Chicago/London, 1986).
- [7] E. van Herwijnen, *Practical SGML* (Kluwer Academic Publishers, Dordrecht, 1994) 2nd (revised) edition.
- [8] *The Chicago Manual of Style* (University of Chicago Press, Chicago/London, 1982) 13th edition.
- [9] American National Standard for Electronic Manuscript Preparation and Markup ANSI/NISO Z39.59–1988 (EPSIG, Dublin, OH, 1988).
- [10] International Standard ISO 12083:1994, *Electronic manuscript preparation and markup* (ISO, Geneva, 1994).
- [11] International Standard ISO 639:1988, *Code for the representation of names of languages* (ISO, Geneva, 1988).
- [12] International Draft Standard 690-2, *Draft standard on information and documentation – Bibliographic references*. (ISO, Geneva, 1987).
- [13] OASIS, CALS Table Model Document Type Definition, OASIS Technical Memorandum TM 9502:1995, <http://oasis-open.org/specs/a502.htm>.
- [14] OASIS, Table Interoperability: Issues for the CALS Table Model, OASIS Technical Research Paper 9501:1995, <http://oasis-open.org/specs/a501.htm>.
- [15] OASIS, OASIS Exchange Table Model Document Type Definition, OASIS Technical Resolution TR 9503:1995, <http://oasis-open.org/specs/a503.htm>.
- [16] SGML Open Technical Resolution 9401:1995: *Entity management*. <http://www.sgmlopen.org/sgml/docs/library/9401.htm>.
- [17] OASIS Technical Committee: Entity Resolution, *XML Catalogs*, Committee Specification 1.0, 24 Oct 2002. <http://www.oasis-open.org/committees/entity/specs/cs-entity-xml-catalogs-1.0.html>.
- [18] OASIS Technical Committee: Entity Resolution, *Overview*. <http://www.oasis-open.org/committees/entity/>.
- [19] Elsevier Copyright Policies, September 1995.
- [20] Elsevier Copyright & Trademark Policies, May 1997.

## Bibliography

- [21] Copyright notices —by status and PIT, documentation from Elsevier Central Application Management, Operations.
- [22] Typographical Standardization, documentation from Elsevier Central Application Management, Operations.
- [23] CAP Guide for MFC Activities, documentation from Elsevier Central Application Management, Operations.
- [24] Mathematical Markup Language (MathML) Version 2.0, W3C Recommendation, 21 February 2001, <http://www.w3.org/TR/MathML2/>.
- [25] The tombstone procedure. 1. Duplicated articles, documentation from Elsevier Central Application Management, Operations.
- [26] The tombstone procedure. 2. Article retraction and article removal, documentation from Elsevier Central Application Management, Operations.
- [27] PII, DOIs and other IDs used by Elsevier, documentation from Elsevier Central Application Management, Operations.

# Index

- #x00A0, entity, [335](#)
- #x02008, entity, [12](#)
-  , closeup sign (used in this documentation to indicate when whitespace, added for readability, must be ignored), [13](#)
- abbr-name, element in the SI DTD, [60](#), [61](#)
- abbreviations, [318](#)
- abs, obsolete element, [167](#)
- abstract
  - graphical, [166](#)
  - stereochemistry, [365](#)
- abstract-class, parameter entity, [166](#)
- acc, obsolete element, [212](#)
- accent, attribute of mml:mo, [439](#)
- ack, obsolete element, [169](#)
- address
  - author, [170](#)
  - correspondence, [205](#)
  - electronic, [229](#)
- affiliation, [170](#)
- aid, element in the JA DTD, [22](#), [32](#), [48](#), [49](#), [228](#), [344](#)
- align
  - attribute of entry, [445](#), [447](#)
  - attribute of tb:colspec, [447](#), [459](#)
- alt, attribute of ce:marker, [331](#)
- altimg
  - attribute of ce:marker, [331](#)
  - attribute of mml:math, [441](#)
  - attribute of tgroup, [455](#)
  - common attribute, [30](#)
- altimg-small, attribute of ce:marker, [331](#)
- alttext, attribute of mml:math, [439](#), [441](#)
- amp, entity, [12](#), [229](#), [296](#)
- anchor, [174](#)
- appendix, [175](#)
- APPLICATION, [14](#), [231](#), [327](#)
- article, element in the JA DTD, [9](#), [22](#), [31](#), [33](#), [37](#), [42](#), [43](#), [51](#)
- artwork, [245](#)
- asset, [5](#), [327](#)
- atl, obsolete element, [172](#), [173](#), [367](#), [382](#)
- atlfm, obsolete element, [177](#)
- au, obsolete element, [180](#)
- AUDIO, [14](#), [231](#), [327](#)
- author
  - corresponding, [205](#)
- author-id
  - attribute of ce:author, [148](#), [178](#), [180](#)
- b, obsolete element, [156](#), [191](#)
- b, line style, [463](#)
- background, attribute of mml:mstyle, [440](#)
- bar, horizontal ornament, [463](#)
- baseline
  - attribute of ce:inline-figure, [290](#)
  - attribute of mml:math, [439](#)
- bb, obsolete element, [430](#)
- bcub, horizontal ornament, [463](#)
- bib, obsolete element, [189](#)
- bibl, obsolete element, [184](#)
- bibliography, [94](#)
- bibliography, element in the Book DTD, [93–95](#), [122](#), [129](#), [131](#), [136](#)
- biographyid
  - attribute of ce:author, [178](#), [190](#)
- bl, line style, [463](#)
- body, element in the JA DTD, [22](#), [35](#), [162](#), [164](#)
- body, element in the Book DTD, [96](#), [98](#), [102](#), [106](#), [128](#), [135](#), [138](#), [145](#)
- book, [98](#)
- book, element in the Book DTD, [93](#), [96](#), [98](#), [99](#), [107](#), [115](#), [122](#)
- book-review, element in the JA DTD, [9](#), [31](#), [34](#), [36](#), [38](#), [43](#), [51](#), [419](#)
- book-review-head, element in the JA DTD, [36](#), [38](#), [45](#), [53](#)
- bpar, horizontal ornament, [463](#)
- break, [192](#)
- bsol, vertical ornament, [463](#)
- bsqb, horizontal ornament, [463](#)
- c, obsolete element, [459](#)

## Index

- CALS table model, [4](#), [7–9](#), [16](#), [22](#), [30](#), [147](#), [165](#), [326](#), [372](#), [443–447](#), [449–451](#), [454](#), [455](#), [457](#)
- CALS tables
  - extended, [444](#)
  - native, [444](#)
- CAP, [5](#)
- CAPCAS, [3](#)
- CAPLite, [5](#), [35](#), [40](#), [45](#), [53](#), [174](#), [222](#), [223](#), [239](#), [248](#), [376](#)
- CAPLitePlus, [5](#), [35](#), [40](#), [45](#), [53](#), [152](#), [174](#), [184](#), [189](#), [222](#), [223](#), [239](#), [248](#), [256](#), [376](#)
- catalog, [14](#), [15](#)
  - XML, [15](#)
- ce:abstract, common element, [44](#), [52](#), [102](#), [103](#), [138](#), [139](#), [148](#), [151](#), [166](#), [168](#), [245](#), [248](#), [357](#)
- ce:abstract-sec, common element, [158](#), [167](#), [168](#), [245](#), [357](#)
- ce:acknowledgment, common element, [35](#), [102](#), [138](#), [142](#), [151](#), [169](#), [357](#), [376](#)
- ce:affiliation, common element, [151](#), [170](#), [181](#)
- ce:alt-e-component, common element, [149](#), [162](#), [163](#), [171](#), [193](#), [230–232](#)
- ce:alt-subtitle, common element, [44](#), [52](#), [86](#), [143](#), [149](#), [158](#), [172](#), [173](#), [272](#), [367](#), [376](#), [382](#)
- ce:alt-title, common element, [38](#), [44](#), [52](#), [86](#), [143](#), [158](#), [172](#), [173](#), [272](#), [367](#), [376](#), [382](#)
- ce:anchor, common element, [151](#), [158](#), [174](#), [407](#)
- ce:appendices, common element, [35](#), [148](#), [162](#), [164](#), [175](#), [376](#)
- ce:article-footnote, common element, [38](#), [40](#), [44](#), [45](#), [52](#), [53](#), [158](#), [177](#), [252](#)
- ce:article-thread, obsolete element, [148](#), [227](#)
- ce:author, common element, [40](#), [45](#), [53](#), [130](#), [148](#), [149](#), [151](#), [178](#), [179](#), [181](#), [190](#), [197](#), [205](#), [219](#), [229](#), [235](#), [258](#), [279](#), [289](#), [347](#), [350](#), [368](#), [370](#), [385](#)
- ce:author-group, common element, [38](#), [40](#), [44](#), [45](#), [52](#), [53](#), [102](#), [103](#), [110](#), [113](#), [124](#), [129](#), [133](#), [134](#), [136](#), [138](#), [142](#), [143](#), [145](#), [146](#), [170](#), [178](#), [180](#), [181](#), [196](#), [197](#), [205](#), [235](#), [376](#)
- ce:bib-reference, common element, [151](#), [152](#), [184](#), [186](#), [187](#), [189](#), [256](#), [410](#)
- ce:bibliography, common element, [54](#), [55](#), [95](#), [102](#), [113](#), [118](#), [120](#), [121](#), [124](#), [129](#), [136](#), [138](#), [142](#), [148](#), [151](#), [152](#), [162](#), [184–186](#), [256](#), [357](#), [376](#)
- ce:bibliography-sec, common element, [151](#), [184](#), [185](#), [357](#)
- ce:biography, common element, [54](#), [55](#), [148](#), [151](#), [158](#), [162](#), [178](#), [190](#), [376](#), [379](#)
- ce:bold, common element, [155](#), [156](#), [158](#), [191](#), [206](#), [316](#), [335](#), [352](#), [363](#), [383](#)
- ce:br, common element, [93](#), [149](#), [154](#), [155](#), [192](#)
- ce:caption, common element, [149](#), [158](#), [193](#), [231](#), [246](#), [361](#), [372](#), [375](#)
- ce:ce:alt-title, common element, [149](#)
- ce:chem, common element, [158](#), [194](#), [253](#), [255](#)
- ce:collab-aff, common element, [158](#), [195–197](#)
- ce:collaboration, common element, [40](#), [45](#), [53](#), [149](#), [151](#), [179–181](#), [195–197](#), [235](#), [370](#), [406](#)
- ce:compound-formula, common element, [158](#), [198](#), [365](#)
- ce:compound-info, common element, [199](#), [365](#)
- ce:compound-name, common element, [158](#), [200](#), [365](#)
- ce:compound-struct, common element, [201](#), [365](#)
- ce:copyright, common element, [48](#), [122](#), [149](#), [158](#), [167](#), [202–204](#), [231](#), [246](#), [372](#), [375](#)
- ce:copyright-line, common element, [143](#), [148](#), [158](#), [204](#)
- ce:correspondence, common element, [151](#), [181](#), [205](#), [347](#)
- ce:cross-out, common element, [154–156](#), [158](#), [191](#), [206](#), [316](#), [335](#), [352](#), [363](#), [383](#)
- ce:cross-ref, common element, [31](#), [149–151](#), [158](#), [164](#), [178](#), [181](#), [184](#), [190](#), [196](#), [205](#), [207](#), [209](#), [210](#), [232](#), [246](#), [247](#), [252](#), [256](#), [261](#), [262](#), [275](#), [280](#), [297](#), [302](#), [305](#), [306](#), [310](#), [324](#), [358](#), [359](#), [372](#), [376](#)
- ce:cross-refs, common element, [31](#), [150](#), [151](#), [158](#), [207–211](#), [246](#), [252](#), [256](#), [297](#), [302](#), [306](#), [310](#), [372](#), [376](#)
- ce:date-accepted, common element, [38](#), [44](#), [52](#), [102](#), [103](#), [138](#), [139](#), [142](#), [212–214](#)
- ce:date-received, common element, [38](#), [44](#), [52](#), [102](#), [103](#), [138](#), [139](#), [142](#), [212–214](#)
- ce:date-revised, common element, [38](#), [44](#), [52](#), [102](#), [103](#), [138](#), [139](#), [142](#), [212–214](#)
- ce:dedication, common element, [44](#), [144](#), [158](#), [215](#)
- ce:def-description, common element, [216](#), [217](#)
- ce:def-list, common element, [151](#), [216–218](#), [329](#), [336](#), [357](#)
- ce:def-term, common element, [151](#), [158](#), [217](#), [218](#)
- ce:degrees, common element, [158](#), [178](#), [219](#), [350](#), [368](#)



- ce:display, common element, [220](#), [231](#), [245](#), [246](#), [248](#), [250](#), [251](#), [253](#), [255](#), [372](#), [375](#), [376](#)
- ce:displayed-quote, common element, [102](#), [138](#), [142](#), [151](#), [158](#), [221](#), [222](#)
- ce:dochead, common element, [38](#), [44](#), [52](#), [223](#), [226](#)
- ce:doctopic, common element, [224](#)
- ce:doctopics, common element, [48](#), [122](#), [223–225](#)
- ce:document-thread, common element, [48](#), [56](#), [57](#), [122](#), [148](#), [227](#), [349](#)
- ce:doi, common element, [32](#), [48](#), [49](#), [75](#), [77](#), [122](#), [158](#), [228](#), [272](#), [344](#), [349](#), [418](#)
- ce:e-address, common element, [158](#), [178](#), [229](#)
- ce:e-component, common element, [148](#), [149](#), [151](#), [162](#), [171](#), [193](#), [202](#), [220](#), [230–233](#), [250](#), [251](#), [364](#)
- ce:edition, common element, [143](#), [144](#), [149](#), [158](#), [234](#)
- ce:editors, common element, [86](#), [143](#), [149](#), [181](#), [235](#)
- ce:enunciation, common element, [151](#), [236](#), [239](#), [357](#), [442](#)
- ce:exam-answers, common element, [55](#), [108](#), [148](#), [151](#), [162](#), [240](#), [357](#)
- ce:exam-questions, common element, [43](#), [55](#), [108](#), [148](#), [151](#), [162](#), [241](#), [343](#), [357](#)
- ce:exam-reference, common element, [55](#), [148](#), [162](#), [244](#)
- ce:figure, common element, [63](#), [104](#), [149](#), [151](#), [166](#), [193](#), [202](#), [220](#), [230–232](#), [245–248](#), [250](#), [251](#), [290](#), [364](#), [375](#)
- ce:first-page, common element, [148](#), [158](#), [249](#), [325](#), [342](#)
- ce:float-anchor, common element, [162](#), [207](#), [231](#), [245](#), [246](#), [248](#), [250](#), [251](#), [361](#), [372](#), [375](#), [376](#)
- ce:floats, common element, [98](#), [102](#), [106](#), [110](#), [113](#), [124](#), [138](#), [162](#), [164](#), [231](#), [245](#), [246](#), [248](#), [250](#), [251](#), [372](#), [375](#), [376](#)
- ce:footnote, common element, [102](#), [103](#), [138](#), [142](#), [151](#), [158](#), [178](#), [181](#), [252](#), [407](#)
- ce:formula, common element, [151](#), [152](#), [194](#), [220](#), [253](#), [254](#), [437](#), [441](#), [442](#)
- ce:further-reading, common element, [54](#), [55](#), [95](#), [102](#), [113](#), [114](#), [118](#), [120](#), [121](#), [124](#), [129](#), [136](#), [138](#), [142](#), [148](#), [151](#), [162](#), [184](#), [186](#), [256](#), [257](#), [357](#), [376](#)
- ce:further-reading-sec, common element, [151](#), [256](#), [257](#), [357](#)
- ce:given-name, common element, [158](#), [178](#), [179](#), [258](#), [289](#), [368](#), [370](#), [401](#), [413](#)
- ce:glossary, common element, [54](#), [55](#), [118](#), [148](#), [151](#), [162](#), [265](#), [337](#), [357](#), [376](#), [379](#)
- ce:glossary-def, common element, [158](#), [260](#), [261](#)
- ce:glossary-entry, common element, [149](#), [151](#), [259–261](#), [264](#)
- ce:glossary-heading, common element, [158](#), [261](#), [264](#)
- ce:glossary-sec, common element, [151](#), [259](#), [265](#), [357](#)
- ce:glyph, common element, [26](#), [160](#), [266](#), [290](#)
- ce:grant-number, common element, [149](#), [169](#), [267–269](#)
- ce:grant-sponsor, common element, [149](#), [169](#), [267–269](#)
- ce:hsp, common element, [154](#), [270](#)
- ce:imprint, common element, [122](#), [148](#), [158](#), [271](#)
- ce:include-item, common element, [70](#), [72](#), [93](#), [94](#), [96](#), [101](#), [109](#), [113](#), [115](#), [117](#), [119](#), [120](#), [124](#), [128](#), [129](#), [131](#), [133](#), [135](#), [136](#), [138](#), [145](#), [148](#), [162](#), [249](#), [272](#), [274](#), [325](#), [342](#)
- ce:index, common element, [120](#), [121](#), [147](#), [148](#), [151](#), [162](#), [280](#), [286](#), [287](#), [357](#)
- ce:index-entry, common element, [149](#), [151](#), [275](#), [278](#), [280](#), [281](#), [285](#), [286](#), [358](#), [359](#)
- ce:index-flag, common element, [93](#), [147](#), [148](#), [151](#), [157](#), [281–285](#)
- ce:index-flag-see, common element, [148](#), [158](#), [281](#), [283](#)
- ce:index-flag-see-also, common element, [148](#), [158](#), [281](#), [284](#)
- ce:index-flag-term, common element, [148](#), [158](#), [281](#), [285](#)
- ce:index-heading, common element, [120](#), [158](#), [275](#), [280](#), [285](#), [286](#)
- ce:index-sec, common element, [120](#), [151](#), [275](#), [278](#), [287](#), [357](#)
- ce:indexed-name, common element, [149](#), [158](#), [178](#), [180](#), [196](#), [197](#), [261](#), [263](#), [279](#), [280](#)
- ce:inf, common element, [154](#), [158](#), [288](#), [369](#)
- ce:initials, common element, [158](#), [178](#), [179](#), [289](#)
- ce:inline-figure, common element, [190](#), [248](#), [290](#)
- ce:inter-ref, common element, [151](#), [158](#), [208](#), [211](#), [232](#), [244](#), [291](#), [295](#), [296](#), [300](#), [302](#), [305](#), [306](#), [310](#), [341](#), [345](#), [397](#), [398](#), [415](#)
- ce:inter-ref-end, common element, [298–301](#)
- ce:inter-ref-title, common element, [150](#), [158](#), [299–302](#), [310](#)

## Index

- ce:inter-refs, common element, 150, 158, 208, 211, 297–301, 303, 304, 306, 309, 310
- ce:inter-refs-link, common element, 300, 301, 303
- ce:inter-refs-text, common element, 151, 158, 300–302, 304, 310
- ce:intra-ref, common element, 31, 147, 150, 151, 158, 208, 211, 261, 262, 275, 280, 281, 297, 305, 306, 309, 310
- ce:intra-ref-end, common element, 307–309
- ce:intra-ref-title, common element, 150, 158, 308–310
- ce:intra-refs, common element, 31, 150, 208, 209, 211, 297, 306–312
- ce:intra-refs-link, common element, 309, 311
- ce:intra-refs-text, common element, 151, 158, 309, 312
- ce:intro, common element, 102, 110, 138, 142, 148, 259, 275, 277, 313, 376
- ce:isbn, common element, 75, 122, 147, 148, 158, 314
- ce:issn, common element, 75, 122, 148, 158, 315
- ce:italic, common element, 155, 156, 158, 191, 206, 316, 335, 352, 363, 383, 442
- ce:keyword, common element, 149, 317, 318, 323
- ce:keywords, common element, 44, 52, 102, 103, 138, 139, 142, 226, 317, 318, 337, 357
- ce:label, common element, 38, 40, 44, 45, 52, 53, 95, 102, 103, 110, 113, 118, 120, 121, 129, 133, 136, 138, 139, 142, 145, 146, 150–152, 158, 170, 174, 177, 181, 186, 187, 194, 205, 209, 210, 217, 231, 236, 239–241, 246, 252–255, 324, 328, 341, 353, 372, 373, 375, 410, 430
- ce:last-page, common element, 72, 148, 158, 249, 325, 342
- ce:legend, common element, 158, 326, 372, 373
- ce:link, common element, 14, 63, 148, 149, 151, 178, 180, 190, 231–233, 246–248, 253, 290, 327, 365, 372, 450, 451
- ce:list, common element, 127, 151, 217, 328, 330, 357
- ce:list-item, common element, 151, 328, 330, 365
- ce:marker, common element, 148, 149, 333
- ce:markers, common element, 38, 40, 44, 45, 52, 53, 148, 149, 333
- ce:miscellaneous, common element, 38, 44, 52, 102, 103, 138, 139, 158, 334
- ce:monospace, common element, 154, 156, 158, 191, 206, 316, 335, 352, 363, 383
- ce:nomenclature, common element, 35, 102, 113, 138, 142, 217, 318, 336, 357
- ce:note, common element, 158, 186, 256, 338, 341, 386, 399, 407
- ce:note-para, common element, 151, 158, 177, 252, 340, 343, 362, 373
- ce:other-ref, common element, 38, 152, 186–188, 341
- ce:pages, common element, 73, 148, 249, 272, 325, 342
- ce:para, common element, 113, 126, 151, 158, 162, 217, 256, 313, 328, 340, 343, 361, 362
- ce:pii, common element, 32, 48, 49, 75, 77, 122, 158, 228, 272, 344, 349
- ce:preprint, common element, 48, 345
- ce:presented, common element, 44, 158, 346
- ce:ranking, common element, 158, 178, 347
- ce:reader-see, common element, 149, 280, 348
- ce:refers-to-article, obsolete element, 148, 349
- ce:refers-to-document, common element, 148, 227, 349
- ce:roles, common element, 158, 178, 219, 350, 368
- ce:salutation, common element, 35, 158, 351
- ce:sans-serif, common element, 154, 156, 158, 191, 206, 316, 335, 352, 363, 383
- ce:section, common element, 102, 103, 135, 138, 142, 151, 162, 163, 175, 176, 240, 241, 353, 357
- ce:section-title, common element, 76, 95, 118, 120, 126, 151, 158, 169, 184, 217, 236, 239, 256, 259, 275, 328, 336, 353, 357
- ce:sections, common element, 35, 102, 103, 113, 124, 136, 138, 142, 143, 356, 376
- ce:see, common element, 149, 158, 275, 278, 280, 283, 286, 348, 358, 360
- ce:see-also, common element, 158, 275, 278, 280, 284, 286, 348, 358, 359
- ce:simple-para, common element, 105, 151, 158, 162, 190, 193, 221, 231, 246, 326, 338, 340, 343, 361, 375
- ce:small-caps, common element, 155, 156, 158, 191, 206, 316, 335, 352, 363
- ce:source, common element, 130, 149, 231, 233, 246, 248, 364, 372, 375, 376
- ce:stereochem, common element, 44, 198–201, 365

- ce:subtitle, common element, [40](#), [44](#), [45](#), [52](#), [53](#), [86](#), [103](#), [139](#), [143](#), [158](#), [172](#), [173](#), [272](#), [367](#), [376](#), [382](#), [433](#)
- ce:suffix, common element, [158](#), [178](#), [219](#), [350](#), [368](#), [401](#), [413](#)
- ce:sup, common element, [154](#), [158](#), [288](#), [369](#)
- ce:surname, common element, [158](#), [178–180](#), [197](#), [258](#), [368](#), [370](#), [401](#), [413](#)
- ce:table, common element, [9](#), [22](#), [151](#), [193](#), [220](#), [250](#), [251](#), [326](#), [364](#), [371](#), [373](#), [445](#), [447](#), [451](#), [454](#)
- ce:table-footnote, common element, [151](#), [158](#), [252](#), [326](#), [372](#), [373](#)
- ce:text, common element, [151](#), [158](#), [196](#), [374](#), [380](#), [381](#)
- ce:textbox, common element, [149](#), [151](#), [193](#), [202](#), [220](#), [222](#), [232](#), [364](#), [375–379](#)
- ce:textbox-body, common element, [376](#), [377](#)
- ce:textbox-head, common element, [376](#), [378](#)
- ce:textbox-tail, common element, [148](#), [376](#), [379](#)
- ce:textfn, common element, [151](#), [158](#), [170](#), [374](#), [380](#), [381](#)
- ce:textref, common element, [151](#), [158](#), [374](#), [380](#), [381](#)
- ce:title, common element, [38](#), [40](#), [44](#), [45](#), [52](#), [53](#), [86](#), [103](#), [108](#), [110](#), [114](#), [130](#), [133](#), [139](#), [142](#), [143](#), [146](#), [158](#), [172](#), [173](#), [223](#), [272](#), [367](#), [376](#), [382](#)
- ce:underline, common element, [154–156](#), [158](#), [191](#), [206](#), [316](#), [335](#), [352](#), [363](#), [383](#)
- ce:vsp, common element, [154](#), [384](#)
- cell
  - border, [458](#), [460–462](#)
- cell.data, parameter entity, [149](#), [158](#), [443](#), [455](#)
- CEP, [147](#)
- chapter, element in the Book DTD, [93](#), [101–103](#), [122](#), [142](#)
- char
  - attribute of entry, [445](#)
- charoff
  - attribute of entry, [445](#)
- chemical formula, [194](#)
- circ, horizontal ornament, [463](#)
- class
  - attribute of ce:abstract, [166](#), [167](#)
  - attribute of ce:keywords, [318](#), [337](#)
- classification code
  - astronomical, [318](#)
  - CTSNNet, [318](#)
  - geo, [318](#)
  - INSPEC, [318](#)
  - JEL, [318](#)
  - MSC, [318](#)
- PACS, [318](#)
- PsycINFO, [318](#)
- STMA, [318](#)
- CME, [42](#), [240](#), [241](#)
- collaboration, [196](#)
  - affiliation, [196](#)
- colname
  - attribute of colspec, [447](#)
  - attribute of entry, [443](#), [444](#)
- colnum
  - attribute of colspec, [447](#)
  - attribute of tb:colspec, [447](#)
- color, attribute of mml:math, [439](#)
- cols, attribute of tgroup, [443](#), [444](#)
- colsep
  - attribute of ce:table, [447](#)
  - attribute of entry, [445](#), [451](#)
- colspec, common element, [22](#), [443–445](#), [447](#), [448](#), [451](#), [454](#), [459](#)
- common element pool, [3](#), [147](#), [165](#), [385](#)
  - structure, [8](#)
- common-altimg.att, parameter entity, [148](#)
- common-reqaltimg.att, parameter entity, [148](#), [149](#)
- common-view.att, parameter entity, [148](#)
- compact view, [162](#)
- compound-f, obsolete element, [198](#)
- computer code, [335](#)
- conference-info, element in the SI DTD, [60](#), [61](#), [67](#), [86](#), [88](#)
- contents-entry-only, [5](#), [33](#), [35](#), [40](#), [45](#), [50](#), [53](#), [174](#), [222](#), [223](#), [239](#), [248](#), [376](#)
- continuous medical education, [42](#), [240](#), [241](#)
- contribution, [386](#)
- copyright, parameter entity, [149](#), [233](#), [248](#), [376](#)
- copyright-type, parameter entity, [202](#)
- correspondence, [205](#)
- corrigendum, [227](#)
- cover-date, element in the SI DTD, [62](#), [73](#)
- cover-image, element in the Book DTD, [104](#), [143](#), [144](#)
- cover-image, element in the SI DTD, [63](#), [73](#)
- cross-ref, obsolete element, [207](#), [209](#)
- cross-ref, parameter entity, [31](#), [149](#), [180](#), [197](#), [262](#)
- cross-reference, [207](#), [209](#)
- cross-refs, parameter entity, [31](#)
- d, line style, [463](#)
- da, line style, [463](#)
- darr, vertical ornament, [463](#)
- dataset, [5](#)
- date
  - acceptance, [212](#)

## Index

- of structured reference, [410](#)
- received, [213](#)
- revised, [214](#)
- date-range, element in the SI DTD, [61](#), [62](#), [64](#),  
[66](#), [84](#)
- day
  - attribute of ce:date-accepted, [212](#)
  - attribute of ce:date-received, [213](#)
  - attribute of ce:date-revised, [214](#)
- dd, obsolete element, [216](#)
- ded, obsolete element, [215](#)
- dedication, [215](#)
- dedication, element in the Book DTD, [105](#),  
[143](#), [144](#)
- definition list, [217](#)
- degrees, [219](#)
- degs, obsolete element, [219](#)
- dharr, vertical ornament, [463](#)
- display, attribute of mml:math, [253](#)
- dl, obsolete element, [217](#)
- docsubtype
  - attribute of article, [33](#), [86](#)
  - attribute of bibliography, [95](#)
  - attribute of book, [99](#)
  - attribute of book-review, [36](#), [37](#)
  - attribute of chapter, [102](#), [103](#), [142](#)
  - attribute of ehs-book, [106](#), [107](#)
  - attribute of exam, [42](#), [43](#)
  - attribute of examination, [110](#)
  - attribute of fb-non-chapter, [113](#), [115](#)
  - attribute of glossary, [118](#)
  - attribute of index, [120](#)
  - attribute of introduction, [124](#)
  - attribute of simple-article, [50](#)
  - attribute of simple-chapter, [138](#)
- docsubtype, parameter entity, [56](#)
- doctype, [9](#)
- DOCTYPE declaration, [14](#), [15](#)
- document heading, [223](#)
- dot, line style, [463](#)
- dt, obsolete element, [218](#)
- DTD, [3](#)
  - family, [8](#)
  - input, [4](#)
  - output, [4](#)
  - version, [10](#), [15](#)
- DTD 4, [3](#), [11](#), [207](#), [209](#), [295](#), [306](#), [439](#), [443](#),  
[444](#)
- e-address-type, parameter entity, [229](#)
- e-component, [230](#)
- ead, obsolete element, [229](#)
- edited-book, obsolete element, [418](#)
- editors, element in the SI DTD, [65](#), [86](#), [87](#)
- EFFECT date format, [64](#)
- EHS books, [106](#)
- ehs-book, obsolete element, [99](#)
- ehs-book, element in the Book DTD, [106](#)
- electronic component, [230](#)
- email, [229](#)
- encoding, UTF-8, [7](#), [12](#)
- end-date, element in the SI DTD, [64](#), [66](#)
- endnote, [338](#), [341](#)
- entity, [14](#)
- entry, common element, [9](#), [22](#), [158](#), [443–445](#),  
[447](#), [448](#), [451](#), [452](#), [454](#), [455](#), [457](#),  
[458](#), [460–462](#)
- enun, obsolete element, [239](#)
- enunciation, [236](#)
- erratum, [227](#)
- exam, element in the JA DTD, [31](#), [34](#), [37](#), [42](#),  
[51](#), [52](#)
- exam, element in the Book DTD, [102](#), [103](#),  
[108](#), [110](#), [111](#), [138](#), [142](#)
- examination, element in the Book DTD, [93](#),  
[103](#), [109](#), [110](#), [122](#), [142](#)
- extended view, [162](#)
- external-file.att, parameter entity, [149](#)
- fb-non-chapter, element in the Book DTD, [93](#),  
[113–115](#), [122](#), [131](#)
- fd, obsolete element, [194](#), [255](#)
- fence, attribute of mml:mo, [439](#)
- fig, obsolete element, [248](#)
- figure, [245](#)
- font, [154](#)
  - bold, [191](#)
  - cross out, [206](#)
  - italic, [316](#)
  - sans serif, [352](#)
  - small caps, [363](#)
  - typewriter, [335](#)
  - underline, [383](#)
- font changes, [154](#)
- font-change, parameter entity, [154](#)
- fontfamily, attribute of mml:math, [438](#), [439](#)
- fontfamily, attribute of mml:mglyph, [439](#)
- fontfamily, attribute of mml:mtext, [440](#)
- fontsize, attribute of mml:math, [439](#)
- fontstyle, attribute of mml:math, [438](#), [439](#)
- fontstyle, attribute of mml:mtext, [440](#)
- fontweight, attribute of mml:math, [438](#), [439](#)
- fontweight, attribute of mml:mtext, [440](#)
- footnote, [252](#)
  - article, [177](#)
  - table, [373](#)
- form, attribute of mml:mo, [439](#)
- frame

- attribute of ce:table, [447](#), [451](#)
- front, element in the Book DTD, [98](#), [99](#), [102](#), [105](#), [106](#), [115](#), [138](#), [144](#)
- full-name, element in the SI DTD, [61](#), [67](#)
- ge, obsolete element, [156](#)
- glossary, element in the Book DTD, [93](#), [117](#), [122](#), [131](#)
- glossary-entry-refs, parameter entity, [149](#), [263](#)
- glyph, [26](#), [266](#)
- glyph-names, parameter entity, [26](#), [159](#), [160](#)
- grant, [268](#)
- harr, horizontal ornament, [463](#)
- Hawaii 5.0, [4](#)
- head, element in the JA DTD, [22](#), [33](#), [38](#), [40](#), [44](#), [52](#), [53](#)
- head-and-tail, [5](#), [35](#), [40](#), [45](#), [53](#), [152](#), [174](#), [184](#), [189](#), [222](#), [223](#), [239](#), [248](#), [256](#), [376](#)
- head-only, [5](#), [35](#), [40](#), [45](#), [53](#), [174](#), [222](#), [223](#), [239](#), [248](#), [376](#)
- header row, [456](#)
- height, attribute of mml:math, [439](#)
- hline, parameter entity, [463](#), [464](#)
- host, [386](#)
- hub, [272](#)
- hyperlink, [291](#), [300](#), [305](#), [309](#)
- id
  - attribute of bibliography, [95](#)
  - attribute of ce:abstract, [166](#), [167](#)
  - attribute of ce:affiliation, [170](#), [181](#)
  - attribute of ce:author, [178](#)
  - attribute of ce:bib-reference, [186](#)
  - attribute of ce:biography, [190](#)
  - attribute of ce:correspondence, [205](#)
  - attribute of ce:def-list, [217](#)
  - attribute of ce:def-term, [217](#)
  - attribute of ce:e-component, [232](#)
  - attribute of ce:enunciation, [236](#)
  - attribute of ce:figure, [245](#), [247](#)
  - attribute of ce:footnote, [252](#)
  - attribute of ce:formula, [254](#), [255](#)
  - attribute of ce:glossary-entry, [261](#)
  - attribute of ce:grant-sponsor, [268](#)
  - attribute of ce:index-flag, [281](#)
  - attribute of ce:link, [149](#)
  - attribute of ce:list, [328](#)
  - attribute of ce:list-item, [328](#)
  - attribute of ce:other-ref, [341](#)
  - attribute of ce:para, [343](#)
  - attribute of ce:section, [354](#)
  - attribute of ce:simple-para, [361](#)
  - attribute of ce:textbox, [376](#)
  - attribute of chapter, [102](#)
  - attribute of examination, [110](#)
  - attribute of fb-non-chapter, [113](#)
  - attribute of glossary, [118](#)
  - attribute of index, [120](#)
  - attribute of introduction, [108](#), [124](#), [130](#)
  - attribute of part, [129](#)
  - attribute of rearpart, [133](#)
  - attribute of sb:reference, [187](#), [430](#)
  - attribute of section, [136](#)
  - attribute of simple-chapter, [138](#)
  - attribute of subchapter, [142](#)
  - attribute of volume, [145](#)
  - common attribute, [150](#), [151](#)
- IMAGE, [14](#), [231](#), [248](#), [327](#)
- include, [272](#)
- index, [119](#), [275](#)
- index, obsolete element, [279](#)
- index terms, [318](#)
- index, element in the Book DTD, [93](#), [119](#), [120](#), [122](#), [131](#)
- index-entry-refs, parameter entity, [149](#), [280](#)
- inferior, [288](#)
- info, [122](#)
- info, element in the Book DTD, [95](#), [98](#), [102](#), [106](#), [110](#), [113](#), [118](#), [120](#), [122](#), [138](#)
- inits, obsolete element, [289](#)
- inline-fig, obsolete element, [290](#)
- input DTD, [4](#)
- inter-ref, obsolete element, [295](#)
- intra-ref, obsolete element, [306](#)
- introduction, element in the Book DTD, [93](#), [122–124](#), [128](#), [129](#), [136](#)
- iso639, parameter entity, [148](#), [149](#), [159](#), [161](#), [167](#), [172](#), [173](#), [323](#), [409](#)
- iss-first, element in the SI DTD, [68](#), [91](#)
- iss-last, element in the SI DTD, [69](#), [91](#)
- issue, obsolete element, [418](#)
- issue hub, [59](#)
- issue-body, element in the SI DTD, [70](#), [76](#)
- issue-data, element in the SI DTD, [73](#)
- issue-designation, element in the SI DTD, [73](#), [74](#)
- issue-info, element in the SI DTD, [75](#)
- issue-sec, element in the SI DTD, [70](#), [72](#), [73](#), [76](#), [357](#)
- it, obsolete element, [156](#), [316](#)
- item-info, element in the JA DTD, [22](#), [48](#)
- jid, element in the JA DTD, [22](#), [32](#), [48](#), [49](#), [228](#), [344](#)
- jid, element in the SI DTD, [75](#), [77](#)
- jr, obsolete element, [368](#)
- keyword, [318](#)

## Index

- kwd, obsolete element, 317
- kwdg, obsolete element, 323
- l, obsolete element, 328
- lang, vertical ornament, 463
- langtype, attribute of sb:contribution, 409
- language, parameter entity, 148, 149, 172, 173, 323
- language codes, 161
- language-type, parameter entity, 409
- largeop, attribute of mml:mo, 439
- larr, horizontal ornament, 463
- lceil, vertical ornament, 463
- lcub, vertical ornament, 463
- lfloor, vertical ornament, 463
- lharu, horizontal ornament, 463
- line break, 192
- line feed, 12
- line, element in the Book DTD, 125, 130, 140
- linked textbox, 376
- list
  - definition, 217
  - free-format, 328
- loc
  - attribute of ce:inf, 288
  - attribute of ce:sup, 369
- local.par.data, parameter entity, 93, 157
- local.spar.data, parameter entity, 93, 157
- locator, attribute of ce:link, 14, 149, 327
- lpar, vertical ornament, 463
- lsqb, vertical ornament, 463
- lt, entity, 12
- macros, attribute of mml:math, 439, 441
- materials and methods, 354
- mathbackground, attribute of mml:math, 439
- mathcolor, attribute of mml:math, 439
- MathML, 4, 7–9, 12, 16, 30, 147, 154–156, 165, 316, 437–441, 447, 448
- mathsize, attribute of mml:math, 439
- mathvariant, attribute of mml:math, 438, 439
- mathvariant, attribute of mml:mtext, 440
- maxsize, attribute of mml:mo, 439
- MDConsult, 3
- mediummathspace, attribute of mml:mstyle, 440
- minsize, attribute of mml:mo, 439
- misc, obsolete element, 334
- mml:maction, common element, 438, 440
- mml:math, common element, 30, 253, 255, 437, 441
- mml:merror, common element, 440
- mml:mglyph, common element, 439
- mml:mstyle, common element, 439, 440
- mml:mtext, common element, 158, 437, 439, 440
- mode, attribute of mml:math, 439, 441
- month
  - attribute of ce:date-accepted, 212
  - attribute of ce:date-received, 213
  - attribute of ce:date-revised, 214
- morerows, attribute of entry, 443, 451
- n, line style, 463
- name
  - attribute of ce:glyph, 266
  - attribute of ce:marker, 331
  - attribute of mml:math, 439
- name, parameter entity, 401, 413
- nameend, attribute of entry, 443, 444, 447, 451
- namespace, 8, 17
  - CALS OASIS Exchange Table Model, 9, 22, 25, 454
  - common element pool, 9, 17, 22
  - EHS Books DTD, 9
  - Elsevier Book DTD, 9
  - extended CALS tables, 9, 22, 443
  - journal article DTD, 9, 22, 25
  - MathML, 9
  - prefix, 9
  - serials issue DTD, 9
  - structured bibliographic references, 9, 22
  - XLink, 9
- namest, attribute of entry, 443, 444, 447, 451
- nbsp, entity, 270
- NDATA, 14
- no, obsolete element, 324
- non-Unicode symbols, 266
- nondisplay.data, parameter entity, 158, 437
- note added in proof, 354
- note.data, parameter entity, 149, 158, 340
- OASIS Exchange Table Model, 454
- objectives, element in the Book DTD, 102, 103, 126, 138, 357
- of, obsolete element, 156
- ornament, 463
- other, attribute of mml:math, 439
- outline, element in the Book DTD, 102, 103, 127, 138
- output DTD, 4
- overflow, attribute of mml:math, 439, 441
- pages, obsolete element, 418
- par.data, parameter entity, 93, 157, 158, 343
- paragraph
  - full, 343

- note, [340](#)
- parameter entity, [157](#)
- parsec, parameter entity, [356](#)
- part, element in the Book DTD, [96](#), [124](#), [128](#), [129](#), [135](#), [145](#)
- PDF, [5](#)
- PIT, [56](#)
- Plane One, [437](#), [438](#)
- plate, [245](#)
- poem, element in the Book DTD, [102](#), [103](#), [125](#), [130](#), [138](#), [140](#)
- prefix, namespace, [9](#)
- presented by, [346](#)
- prs, obsolete element, [346](#)
- public identifier, [15](#)
- publication item type, [56](#)
- PubMed, [3](#)
- puncsp, entity, [270](#)
  
- qd, obsolete element, [222](#)
- quot, entity, [12](#)
  
- rang, vertical ornament, [463](#)
- rarr, horizontal ornament, [463](#)
- rceil, vertical ornament, [463](#)
- rcub, vertical ornament, [463](#)
- re, obsolete element, [213](#)
- rear, element in the Book DTD, [98](#), [99](#), [102](#), [106](#), [131](#), [138](#)
- rearpart, element in the Book DTD, [131](#), [133](#)
- refid
  - attribute of ce:cross-ref, [207](#), [209](#)
  - attribute of ce:float-anchor, [250](#)
  - attribute of ce:grant-number, [267](#)
- rfloor, vertical ornament, [463](#)
- rharu, horizontal ornament, [463](#)
- richstring.data, parameter entity, [154](#), [158](#)
- role
  - attribute of bibliography, [95](#)
  - attribute of ce:anchor, [174](#)
  - attribute of ce:caption, [149](#), [193](#)
  - attribute of ce:displayed-quote, [221](#)
  - attribute of ce:doctopic, [226](#)
  - attribute of ce:e-component, [149](#), [231](#), [233](#)
  - attribute of ce:include-item, [72](#), [272–274](#)
  - attribute of ce:index, [275](#)
  - attribute of ce:para, [343](#)
  - attribute of ce:section, [354](#)
  - attribute of ce:simple-para, [361](#)
  - attribute of ce:textbox, [376](#)
  - attribute of chapter, [103](#)
  - attribute of examination, [110](#), [111](#)
  - attribute of fb-non-chapter, [114](#)
  - attribute of glossary, [118](#)
  - attribute of index, [95](#), [96](#), [120](#), [121](#)
  - attribute of introduction, [102](#), [108](#), [113](#), [124](#), [130](#), [138](#), [142](#)
  - attribute of part, [129](#), [136](#)
  - attribute of rearpart, [133](#), [134](#), [146](#)
  - attribute of section, [136](#)
  - attribute of subchapter, [142](#)
  - attribute of volume, [145](#)
- row, common element, [22](#), [445](#), [447](#), [452](#), [455](#)
- rowsep
  - attribute of ce:table, [447](#)
  - attribute of entry, [445](#), [451](#)
  - attribute of row, [447](#), [452](#)
- rpar, vertical ornament, [463](#)
- rsqb, vertical ornament, [463](#)
- rv, obsolete element, [214](#)
  
- s, line style, [463](#)
- sb.titles, parameter entity, [148](#), [404](#), [409](#), [411](#), [431](#)
- sb:author, common element, [385](#), [401](#), [402](#), [406](#)
- sb:authors, common element, [402](#), [409](#)
- sb:book, common element, [148](#), [390](#), [397](#), [403–405](#), [418](#), [433](#), [434](#)
- sb:book-series, common element, [386](#), [395](#), [396](#), [405](#), [411](#), [414](#), [431](#)
- sb:collaboration, common element, [158](#), [402](#), [406](#)
- sb:comment, common element, [148](#), [158](#), [256](#), [338](#), [386](#), [399](#), [407](#), [430](#)
- sb:conference, common element, [158](#), [394](#), [408](#), [411](#), [421](#)
- sb:contribution, common element, [148](#), [389–391](#), [395](#), [396](#), [398](#), [399](#), [403](#), [409](#), [430](#), [433](#), [434](#)
- sb:date, common element, [158](#), [186](#), [386](#), [390](#), [391](#), [396](#), [397](#), [403](#), [410](#), [411](#), [415](#), [421](#)
- sb:e-host, common element, [397](#), [415](#), [418](#)
- sb:edited-book, common element, [148](#), [391](#), [394](#), [396–398](#), [405](#), [408](#), [411](#), [414](#), [418](#), [428](#), [433](#), [434](#)
- sb:edition, common element, [158](#), [390](#), [403](#), [411](#), [412](#)
- sb:editor, common element, [413](#), [414](#)
- sb:editors, common element, [411](#), [414](#), [421](#)
- sb:et-al, common element, [402](#), [414](#), [416](#)
- sb:first-page, common element, [158](#), [417](#), [424](#), [428](#)
- sb:host, common element, [390](#), [391](#), [398](#), [399](#), [409](#), [418](#), [421](#), [428](#), [430](#)
- sb:isbn, common element, [158](#), [403](#), [411](#), [419](#)

## Index

- sb:issn, common element, [158](#), [420](#)
- sb:issue, common element, [386](#), [391](#), [397](#), [408](#), [414](#), [418](#), [421](#), [428](#), [431](#), [433](#), [434](#)
- sb:issue-nr, common element, [158](#), [387](#), [421](#), [423](#)
- sb:last-page, common element, [158](#), [417](#), [424](#), [428](#)
- sb:location, common element, [158](#), [425](#), [429](#)
- sb:maintitle, common element, [158](#), [426](#), [433](#), [434](#)
- sb:name, common element, [158](#), [427](#), [429](#)
- sb:pages, common element, [418](#), [421](#), [428](#)
- sb:publisher, common element, [390](#), [396](#), [403](#), [411](#), [425](#), [427](#), [429](#)
- sb:reference, common element, [22](#), [38](#), [152](#), [186–188](#), [341](#), [386](#), [430](#)
- sb:series, common element, [148](#), [386](#), [388](#), [395](#), [405](#), [420](#), [421](#), [431](#), [433](#), [434](#)
- sb:subtitle, common element, [158](#), [432–434](#)
- sb:title, common element, [386](#), [388](#), [390](#), [391](#), [398](#), [411](#), [421](#), [426](#), [432–434](#)
- sb:translated-title, common element, [386](#), [389](#), [411](#), [421](#), [434](#)
- sb:volume-nr, common element, [158](#), [386](#), [395](#), [435](#)
- sbt, obsolete element, [172](#), [367](#)
- sc, obsolete element, [156](#)
- schema, [8](#)
- scheme, [245](#)
- ScienceDirect, [3](#), [418](#)
- Scopus, [3](#)
- scp, obsolete element, [156](#), [363](#)
- scriptminsize, attribute of mml:mstyle, [440](#)
- scriptsizemultiplier, attribute of mml:mstyle, [440](#)
- sec, obsolete element, [355](#)
- section, [353](#)
  - case report, [354](#)
  - materials and methods, [354](#)
  - note added in proof, [354](#)
  - results, [354](#)
- section, element in the Book DTD, [96](#), [124](#), [129](#), [135](#), [136](#), [145](#)
- see, parameter entity, [149](#), [280](#)
- separator, attribute of mml:mo, [439](#)
- serial-issue, element in the SI DTD, [59](#), [78](#)
- SGML, [3](#)
- SGML First, [5](#)
- simple-article, element in the JA DTD, [31](#), [33](#), [34](#), [37](#), [43](#), [50](#), [52](#)
- simple-chapter, element in the Book DTD, [93](#), [103](#), [122](#), [138](#)
- simple-head, element in the JA DTD, [40](#), [44](#), [45](#), [52](#)
- simple-tail, element in the JA DTD, [54](#), [55](#)
- size-info.att, parameter entity, [149](#)
- sol, vertical ornament, [463](#)
- sp
  - attribute of ce:hsp, [270](#)
  - attribute of ce:vsp, [384](#)
- space, [12](#)
  - horizontal, [270](#)
  - vertical, [384](#)
- spar.data, parameter entity, [93](#), [157](#), [158](#), [361](#)
- sponsor, [268](#)
- sponsor, element in the SI DTD, [82](#), [83](#)
- sponsor-id, attribute of ce:grant-number, [268](#)
- sponsors, element in the SI DTD, [82](#), [83](#), [86](#)
- ssf, obsolete element, [156](#), [352](#)
- st, obsolete element, [357](#)
- standard view, [162](#)
- stanza, element in the Book DTD, [125](#), [130](#), [140](#)
- start-date, element in the SI DTD, [64](#), [84](#)
- stereochemistry abstract, [365](#)
- stretchy, attribute of mml:mo, [439](#)
- string.data, parameter entity, [158](#)
- strip-in, [30](#), [441](#), [455](#)
- stubs, [456](#)
- style
  - attribute of mml:math, [438](#), [439](#), [441](#)
  - attribute of tb:bottom-border, [458](#)
  - attribute of tb:left-border, [460](#)
  - attribute of tb:right-border, [461](#)
  - attribute of tb:top-border, [462](#)
- style, parameter entity, [463](#), [464](#)
- subchapter, [142](#)
- subchapter, element in the Book DTD, [102](#), [138](#), [141](#), [142](#)
- SUBDOC, [376](#)
- subscript, [288](#)
- subsection, [353](#)
- superior, [369](#)
- superscript, [369](#)
- suppl, element in the SI DTD, [85](#), [91](#)
- symmetric, attribute of mml:mo, [439](#)
- t, line style, [463](#)
- table, [371](#)
- table footnote, [373](#)
- tail, element in the JA DTD, [22](#), [42](#), [54](#), [55](#), [164](#)
- tb:alignmark, common element, [444](#), [446](#), [447](#), [455](#), [457](#), [459](#)
- tb:bottom-border, common element, [455](#), [458](#), [463](#)
- tb:colspec, common element, [443–447](#), [454](#), [457](#), [459](#)



- tb:left-border, common element, [449](#), [451](#), [455](#), [460](#), [463](#)
- tb:right-border, common element, [449](#), [451](#), [455](#), [461](#), [463](#)
- tb:top-border, common element, [449](#), [455](#), [462](#), [463](#)
- tbl.colspec.att, parameter entity, [149](#)
- tbl.row.att, parameter entity, [149](#)
- tbl.tgroup.att, parameter entity, [148](#)
- tbl.titles, parameter entity, [149](#)
- tbody, common element, [22](#), [443](#), [445](#), [447](#), [455](#), [457](#)
- tcub, horizontal ornament, [463](#)
- TEXT, [14](#), [327](#)
- text effects, [154](#)
- text-effect, parameter entity, [154](#)
- text-objects, parameter entity, [149](#)
- text.data, parameter entity, [158](#), [374](#)
- textfn.data, parameter entity, [93](#), [158](#), [380](#)
- textref.data, parameter entity, [158](#), [381](#)
- tgroup, common element, [22](#), [30](#), [372](#), [443–445](#), [447](#), [450](#), [451](#), [455](#)
- thead, common element, [22](#), [443](#), [445](#), [447](#), [456](#)
- theorem, [236](#)
- thickmathspace, attribute of mml:mstyle, [440](#)
- thinmathspace, attribute of mml:mstyle, [440](#)
- tilde, horizontal ornament, [463](#)
- title
  - in alternative language, [173](#)
  - of an author, [219](#)
  - of article or chapter, [382](#)
  - of bibliographic reference, [433](#)
  - translated, [434](#)
- title-editors-group, element in the SI DTD, [65](#), [73](#), [86](#)
- titles, parameter entity, [95](#), [102](#), [103](#), [113](#), [114](#), [118](#), [120](#), [121](#), [124](#), [129](#), [136](#), [138](#), [139](#), [142](#), [145](#), [146](#), [148](#)
- top, [143](#)
- top, element in the Book DTD, [98](#), [99](#), [106](#), [107](#), [115](#), [143](#), [144](#)
- topic hierarchy, [224](#), [225](#)
- tpar, horizontal ornament, [463](#)
- tsqb, horizontal ornament, [463](#)
- ty, obsolete element, [156](#), [335](#)
- type
  - attribute of ce:copyright, [202](#), [203](#)
  - attribute of ce:e-address, [229](#)
  - attribute of mml:math, [439](#)
  - attribute of tb:bottom-border, [458](#)
  - attribute of tb:left-border, [460](#)
  - attribute of tb:right-border, [461](#)
  - attribute of tb:top-border, [462](#)
- uarr, vertical ornament, [463](#)
- uharr, vertical ornament, [463](#)
- ultralight, [5](#)
- Unicode, [4](#), [12](#)
  - UTF-8, [7](#), [12](#)
- upi, obsolete element, [232](#)
- UTF-8 encoding, [7](#), [12](#)
- valign
  - attribute of entry, [445](#)
- varr, vertical ornament, [463](#)
- vb, vertical ornament, [463](#)
- venue, element in the SI DTD, [61](#), [88](#)
- verbatim, [335](#)
- version, [10](#), [15](#)
  - attribute of article, [15](#), [33](#)
  - attribute of bibliography, [95](#)
  - attribute of book, [99](#)
  - attribute of book-review, [36](#)
  - attribute of chapter, [102](#)
  - attribute of ehs-book, [106](#)
  - attribute of exam, [42](#)
  - attribute of examination, [110](#)
  - attribute of fb-non-chapter, [113](#)
  - attribute of glossary, [118](#)
  - attribute of index, [120](#)
  - attribute of introduction, [124](#)
  - attribute of serial-issue, [78](#)
  - attribute of simple-article, [50](#)
  - attribute of simple-chapter, [138](#)
- vertical mark, [457](#)
- verythickmathspace, attribute of mml:mstyle, [440](#)
- verythinmathspace, attribute of mml:mstyle, [440](#)
- veryverythickmathspace, attribute of mml:mstyle, [440](#)
- veryverythinmathspace, attribute of mml:mstyle, [440](#)
- VIDEO, [14](#), [231](#), [327](#)
- view, [162](#), [343](#), [354](#), [361](#)
  - attribute of ce:appendices, [148](#), [176](#), [184](#), [190](#), [240](#), [241](#), [244](#), [256](#), [259](#), [277](#)
  - attribute of ce:include-item, [72](#)
  - attribute of ce:para, [343](#)
  - attribute of ce:section, [354](#)
  - attribute of ce:simple-para, [361](#)
  - attribute of introduction, [108](#), [130](#), [142](#)
  - common attribute, [162](#), [232](#)
- view, parameter entity, [162](#)
- vline, parameter entity, [463](#), [464](#)
- vol-first, element in the SI DTD, [89](#), [91](#)
- vol-last, element in the SI DTD, [90](#), [91](#)
- volume, [145](#)

## Index

- volume, element in the Book DTD, 96, 128, 135, 145
- volume-issue-number, element in the SIDTD, 68, 69, 75, 85, 89–91
- vt, obsolete element, 190
- weight, 5
- width, attribute of mml:math, 439
- XLink, 4, 9, 33, 36, 42, 50, 78, 150, 209, 291, 295, 300, 303, 305, 306, 309–311
- xlink:from
  - attribute of ce:inter-refs-link, 301
- xlink:href
  - attribute of ce:grant-sponsor, 268
  - attribute of ce:inter-ref, 244, 291–297, 345
  - attribute of ce:inter-ref-end, 300
  - attribute of ce:intra-ref, 305, 306
  - attribute of ce:intra-ref-end, 309
  - attribute of mml:math, 439
- xlink:label
  - attribute of ce:inter-ref-end, 301
  - attribute of ce:inter-refs-text, 301
- xlink:role
  - attribute of ce:inter-ref, 291–293, 295
  - attribute of ce:inter-ref-end, 300
  - attribute of ce:intra-ref, 305, 306
  - attribute of ce:intra-ref-end, 309
- xlink:to
  - attribute of ce:inter-refs-link, 301
- xlink:type
  - attribute of ce:inter-ref, 295
  - attribute of ce:inter-ref-end, 301
  - attribute of ce:inter-ref-title, 301
  - attribute of ce:inter-refs, 301
  - attribute of ce:inter-refs-link, 301
  - attribute of ce:inter-refs-text, 301
  - attribute of ce:intra-ref, 306
  - attribute of ce:intra-refs, 310
  - attribute of mml:math, 439
- XML, 3, 14, 231, 327
  - contents-entry-only, 5, 33, 35, 40, 45, 50, 53, 174, 222, 223, 239, 248, 376
  - head-and-tail, 5, 35, 40, 45, 53, 152, 174, 184, 189, 222, 223, 239, 248, 256, 376
  - head-only, 5, 35, 40, 45, 53, 174, 222, 223, 239, 248, 376
  - schema, 8
- XML First, 5
- xml:lang
  - attribute of article, 33, 34
  - attribute of bibliography, 95
  - attribute of book, 99
  - attribute of book-review, 36, 37
  - attribute of ce:abstract, 148, 166, 167
  - attribute of ce:alt-subtitle, 172
  - attribute of ce:alt-title, 173
  - attribute of ce:caption, 149, 193
  - attribute of ce:keywords, 318
  - attribute of chapter, 102
  - attribute of ehs-book, 106
  - attribute of exam, 42, 43
  - attribute of examination, 110
  - attribute of fb-non-chapter, 113
  - attribute of glossary, 118
  - attribute of index, 120
  - attribute of introduction, 124
  - attribute of sb:contribution, 389, 409
  - attribute of serial-issue, 78
  - attribute of simple-article, 50, 51
  - attribute of simple-chapter, 138
  - common attribute, 161
- xmlns
  - attribute of article, 33
  - attribute of bibliography, 95
  - attribute of book, 99
  - attribute of book-review, 36
  - attribute of ce:table, 454
  - attribute of chapter, 102
  - attribute of ehs-book, 106
  - attribute of exam, 42
  - attribute of examination, 110
  - attribute of fb-non-chapter, 113
  - attribute of glossary, 118
  - attribute of index, 120
  - attribute of introduction, 124
  - attribute of serial-issue, 78
  - attribute of simple-article, 50
  - attribute of simple-chapter, 138
- xmlns:ce
  - attribute of article, 33
  - attribute of bibliography, 95
  - attribute of book, 99
  - attribute of book-review, 36
  - attribute of chapter, 102
  - attribute of ehs-book, 106
  - attribute of exam, 42
  - attribute of examination, 110
  - attribute of fb-non-chapter, 113
  - attribute of glossary, 118
  - attribute of index, 120
  - attribute of introduction, 124
  - attribute of serial-issue, 78
  - attribute of simple-article, 50
  - attribute of simple-chapter, 138

- xmlns:sb
  - attribute of article, [33](#)
  - attribute of book-review, [36](#)
  - attribute of exam, [42](#)
  - attribute of serial-issue, [78](#)
  - attribute of simple-article, [50](#)
- xmlns:xlink
  - attribute of article, [33](#)
  - attribute of bibliography, [95](#)
  - attribute of book, [99](#)
  - attribute of book-review, [36](#)
  - attribute of chapter, [102](#)
  - attribute of ehs-book, [106](#)
  - attribute of exam, [42](#)
  - attribute of examination, [110](#)
  - attribute of fb-non-chapter, [113](#)
  - attribute of glossary, [118](#)
  - attribute of index, [120](#)
  - attribute of introduction, [124](#)
  - attribute of serial-issue, [78](#)
  - attribute of simple-article, [50](#)
  - attribute of simple-chapter, [138](#)
- xsi:schemaLocation, attribute of mml:math, [439](#)
  
- year
  - attribute of ce:copyright, [202](#)
  - attribute of ce:date-accepted, [212](#)
  - attribute of ce:date-received, [213](#)
  - attribute of ce:date-revised, [214](#)