



STREETFIGHTER

Owner's manual

ENGLISH

STREETFIGHTER V4

Dear Ducatista,

thank you for trusting us with the purchase of your new Streetfighter V4.

We recommend that you **read the use and maintenance manual carefully**, to quickly get familiar with your Ducati and **make the most of all its features**. In the manual, we provide lots of useful advice and information on your **safety**, on how to **take care** of your bike and on how to maintain its value through **correct maintenance** by specialist Service Centres.

You can also find this manual in **digital format, always up-to-date, in the dedicated area of the Ducati website** and **in the MyDucati App**, which can be consulted both from a PC and a phone.



In this way, you will always have the **most up-to-date version of the manual** available and you will also find **information and frequently asked questions** regarding your bike and the world of Ducati.

You can send suggestions for improvement regarding the contents of this Use and maintenance manual to the following address: OwnerManual@ducati.com

This manual forms an integral part of the motorcycle and must be kept with it for its whole service life. If the motorcycle is resold, the manual must always be handed over to the new owner. The quality standards and safety of Ducati motorcycles are steadily improved as new design solutions, equipment and accessories are developed. While the information contained in this manual is current at the time of going to print, Ducati Motor Holding S.p.A. reserves the right to make changes at any time without notice and without any obligations. For this reason, the illustrations in this manual might differ from your motorcycle. Any and all reproduction or spreading of the contents herein in whole or in part is forbidden. All rights reserved to Ducati Motor Holding S.p.A. Any request for written authorisation shall be addressed to this company, specifying the reasons for request. For any servicing or suggestions you might need, please contact our authorised service centres.

For further information, please contact us at:

contact_us@ducati.com

Our Advisors are available to give you suggestions and useful tips.



Important

For further information, please contact the Ducati Support by clicking on "Contact us" in the Services and Maintenance section of the www.ducati.com website.

Our Advisors are available to give you suggestions and useful tips.

Enjoy your ride!

Roadside Assistance



ACI Global Servizi

Important

The "ACI Global Services" roadside assistance is in force only in the following countries:

Denmark, Belgium, France, Luxembourg, Switzerland, Ireland, United Kingdom, Italy, Norway, Holland, Spain, Austria, Germany, Sweden, Portugal, Canary Islands, Cyprus, Croatia, Czech Republic, Estonia, Latvia, Lithuania, Finland, Greece, Hungary, Malta, Poland, Serbia and Montenegro, Slovakia, Slovenia, Turkey, Ukraine.

The Ducati Card Assistance Programme, created in collaboration with Ducati and ACI Global Services, offers assistance in case of breakdown and/or accident to the Ducati Customer. The service is active 24 hours a day, 365 days a year, for 24 months (in case of extended warranty the relevant conditions will apply) from the date of delivery of the

motorcycle or for the period of coverage of the Ever Red warranty extension.

The roadside assistance services include:

- Roadside assistance and towing
- Information Service
- Transport of passengers following roadside assistance
- Return of passengers or continuation of the journey
- Recovery of the repaired or found motorcycle
- Repatriation of the motorcycle from abroad
- Search and sending of spare parts abroad
- Hotel expenses
- Recovery of the motorcycle off the road in case of accident
- Advance payment of bail abroad

and may be requested in the following countries: Andorra, Austria, Belgium, Bulgaria, Croatia, Cyprus, Czech Republic, Estonia, Finland, France (including Corsica, roads open to ordinary traffic) Fyrom (the former Yugoslav Republic of Macedonia), Germany, Gibraltar, Greece, Hungary, Ireland, Iceland, Italy (including San Marino and the Vatican), Latvia, Lithuania, Luxembourg, Malta, Montenegro, the

Netherlands, Norway, Poland, Portugal, Monaco, Romania, Serbia, Slovakia, Slovenia, Spain, Sweden, Switzerland, Turkey, Ukraine, United Kingdom.

Important

All information is detailed and available on the Ducati website of the respective country.

Call Centre telephone numbers

To request Assistance:

Event in the country of origin: call the toll-free number for your country as specified in the first column of the table.

Event out of the country of origin: call the paid number for your country including the prefix, as specified in the second column of the table.

Should you have any problems in calling the number for your country from abroad, dial the phone number of the country where the Event has occurred.

Attention

If phone numbers are temporarily inactive due to a malfunction to telephone lines, the Beneficiary may call the number of ACI Global Servizi Operations Centre in Italy: +39-02 66165610.

Andorra	+34-91-594 93 40	+34-91-594 93 40
Austria	0800-22 03 50	+43-1-25 119 19398
Belgium	0800-14 134	+32-2-233 22 90
Bulgaria	(02)-986 73 52	+359-2-986 73 52
Cyprus	25 561580	+357-25 561580
Croatia	0800-79 87	+385-1-464 01 41
Denmark	80 20 22 07	+45-80 20 22 07
Estonia	(0)-69 79 199	+372-69 79 199
Finland	(09)-77 47 64 00	+358-9-7747640 0
France (+Corsica)	0800-23 65 10	+33-4-72 17 12 83
FYROM	(02)-3181 192	+389-2-3181 192
Germany	0800-27 22 774	+49-89-76 76 40 90
Gibraltar	91-594 93 40	+34-91-594 93 40
Greece	(210)-9462 058	+30-210-9462 058

Ireland	1800-304 500	+353-1-617 95 61
Iceland	5 112 112	+354-5 112 112
Italy	800.744.444	+39 02 66.16.56.10
Latvia	67 56 65 86	+371-67 56 65 86
Lithuania	(85)-210 44 25	+370-5-210 44 25
Luxembourg	25 36 36 301	+352-25 36 36 301
Malta	21 24 69 68	+356-21 24 69 68
Monaco	+33-4-72 17 12 83	+33-4-72 17 12 83
Montenegro	0800-81 986	+382-20-234 038
Norway	800-30 466	+47-800-30 466
Holland	0800-099 11 20	+31-70-314 51 12
Poland	061 83 19 885	+48 61 83 19 885
Portugal	800-20 66 68	+351-21-942 91 05
United King- dom	00800-33 22 88 77	00800-33 22 88 77
Czech Republic	261 10 43 48	+420-2-61 10 43 48

Romania	021-317 46 90	+40-21-317 46 90
Serbia	(011)-240 43 51	+381-11-240 43 51
Slovakia	(02)-492 05 963	+421-2-49 20 59 63
Slovenia	(01)-530 53 10	+386-1-530 53 10
Spain	900-101 576	+34-91-594 93 40
Sweden	020-88 87 77	+46-771-88 87 77 (+46 8 5179 2873)
Switzerland (+Liechten- stein)	0800-55 01 41	+41 58 827 60 86
Turkey	(216) 560 07 50	+90 216 560 07 50
Ukraine	044-494 29 52	+380-44-494 29 52
Hungary	(06-1)-345 17 47	+36-1-345 17 47

Table of contents

Warranty information	11	Vehicle identification number	28
General warranty conditions	11	Engine identification number	29
General Information.....	18	Main components and devices	30
Acronyms and abbreviations used in the Manual.....	18	Position on the vehicle	30
Warning symbols used in the manual	18	Tank filler plug	31
Intended use.....	19	Removing and refitting the seats	32
Rider's obligations	19	Maintaining the battery charge.....	36
Rider's training.....	20	Side stand	38
Apparel	20	Bluetooth control unit.....	40
"Safety ""Best Practices""	21	Steering damper	42
Refuelling.....	24	Front fork adjustment	43
Carrying the maximum load allowed	25	Adjusting the rear shock absorber	45
Information about carrying capacity.....	25	Controls	47
Dangerous products - warnings	26	Position of motorcycle controls	47
		Switchgears	48
		Light control	51
		Keys.....	57
		Ignition switch and steering lock	59
		Restoring motorcycle operation via the PIN code	60
		Clutch lever	61
		Throttle twistgrip	62

Front brake lever	63	Clock.....	92
Rear brake pedal.....	64	Engine Coolant temperature.....	93
Gear change pedal.....	65	Riding Mode	94
Adjusting the position of the gearchange pedal and rear brake pedal.....	66	Parameter menu and quick level change.....	97
Riding the motorcycle	67	DTC indicator	99
Running-in recommendations.....	67	DWC indicator	105
Pre-ride checks.....	68	DSC indication.....	111
Engine start/stop	71	EBC indication.....	114
Moving off	73	ABS indicator.....	118
Anti-Lock Braking System (ABS).....	74	DQS indicator	125
Motorcycle braking and stop.....	75	Function menu	127
Parking.....	76	TOT	128
Refueling.....	77	TRIP 1.....	129
Tool kit and accessories.....	79	CONS. AVG 1	130
Instrument panel (Dashboard).....	80	SPEED AVG 1	131
Instrument panel.....	80	TRIP 1 TIME	132
Display mode (Info Mode)	83	T AIR	133
Main and auxiliary functions.....	87	TRIP FUEL	134
Vehicle speed indication.....	89	TRIP 2	135
Gear indication.....	90	CONS. I.	136
Engine rpm indication	91	LAP (OFF / ON).....	137
		PLAYER (OFF / ON).....	138
		LAST CALLS.....	143
		SETTING MENU	144
		SETTING MENU - Riding Mode	146

Scheduled maintenance chart: operations to be performed by the Dealer	147	SETTING MENU - DRL.....	181
SETTING MENU - Riding Mode - DAVC - DTC	148	Removing the filler plug lock	182
SETTING MENU - Riding Mode - DAVC - DWC.....	149	SETTING MENU - DDA	187
SETTING MENU - Riding Mode - DAVC - DSC	148	SETTING MENU - Turn indicators	189
SETTING MENU - Riding Mode - DAVC - Default	151	SETTING MENU - Info	190
SETTING MENU - Riding Mode - Engine..	152	Lap time (LAP)	191
SETTING MENU - Riding Mode - ABS.....	153	Assisted start (DPL)	197
SETTING MENU - Riding Mode - EBC.....	154	Infotainment	203
SETTING MENU - Riding Mode - DQS	155	Heated handgrips.....	208
SETTING MENU - Riding Mode - Info Mode	156	Side stand status indication	210
SETTING MENU - Riding Mode - Default.	157	Service indication (SERVICE).....	211
SETTING MENU - Riding Mode - All Default.....	158	Error indication	215
SETTING MENU - Pin Code	159	Warnings and alarms	216
SETTING MENU - Lap.....	164		
SETTING MENU - Backlight	169	Main use and maintenance	
SETTING MENU - Date and Clock	170	operations	221
SETTING MENU - Units.....	173	Removing the fairing	221
SETTING MENU - Service	177	"Checking coolant level and topping up, if necessary"	222
SETTING MENU - Tire Calibration.....	178	Checking brake and clutch fluid level.....	223
		Checking brake pads for wear	225
		Charging the battery.....	226
		Checking drive chain tension	231
		Lubricating the drive chain.....	233
		Replacing the high and low beam bulbs...	238

Turn indicators	238	Performance	264
Aligning the headlight.....	239	Spark plugs	264
Adjusting the rear-view mirrors.....	241	Fuel system.....	264
Tubeless tyres	242	Brakes	264
Check engine oil level	244	Transmission	265
Cleaning the motorcycle	246	Frame.....	266
Cleaning and replacing the spark plugs	248	Wheels	266
Storing the motorcycle	249	Tyres.....	267
Important notes.....	249	Suspensions.....	267
Vehicle transport	251	Exhaust system.....	267
		Available colours.....	268
		Electric system.....	269
Scheduled maintenance chart.....	252		
Scheduled maintenance chart: operations to be carried out by the dealer	252	Open source software	273
Scheduled maintenance chart: operations to be carried out by the customer	256	Information about open source software ..	273
Technical data	257	Declarations of conformity	274
Weights	257	Declarations of conformity	274
Overall dimensions.....	258		
Top-ups	259		
Engine.....	261		
Timing system.....	263		

Warranty information

General warranty conditions

1. Warranty content

1.1 Ducati Motor Holding S.p.A. - A Sole partner company- a Company of the Audi Group, with headquarters in via Cavalieri Ducati no. 3, 40132, Bologna, Italy (hereafter "Ducati") - guarantees anywhere in the world where its official service network is present (see "World Dealer Guide" available at www.ducati.com) that all of its new motorcycles, manufactured for road use, for a period of twenty-four (24) months with no mileage/km limitation from the delivery date of the motorcycle to the first owner, shall be free of defects in workmanship as ascertained and recognised by Ducati.

1.2 In such cases, the Customer has the right to the repair or replacement of defective parts, free of charge.

1.3 The defective parts replaced under warranty become the property of Ducati.

1.4 The new parts replaced under warranty or repaired are covered by warranty for the remaining outstanding warranty period of the motorcycle.

1.5 Also, through a specific insurance policy taken out with ACI GLOBAL S.p.A, Ducati offers the Customer additional roadside assistance services in the Countries listed in the "Owner's manual", according to the specific terms and procedures reported therein, which are here fully referred to.

1.6 These general warranty conditions (hereinafter the "Warranty Conditions") do not affect the remedies for lack of conformity against the seller that the consumers have at their disposal by law, free of charge, in accordance with European regulations, as implemented in Italy by Legislative Decree no. 206 of 6 September 2005, and following amendments (so called Codice del Consumo or Consumer Code): In the event any one provision of these Warranty Conditions should conflict with mandatory law in force in the country of residence or domicile of the "consumer" such provision shall be treated as null and void.

2. Exclusions

2.1 This warranty offered by Ducati is not applicable to:

- a) motorcycles used in sporting competitions of any kind;
- b) motorcycles used in rental service;
- c) parts subject to wear and tear during normal operation of the motorcycle (such as for example: tyres, final drive, belts, flexible controls, spark plugs, brake and clutch parts subject to friction, the vehicle battery if not properly maintained using the Ducati battery maintainer);
- d) defects deriving from oxidation or caused by atmospheric agents extraordinary environmental conditions or circumstances or due to irregular or improper washing of the motorcycle;

2.2 Without prejudice to the provisions of the mandatory provisions for the protection of the consumer relating to the legal warranty pursuant to the national regulations transposing and implementing European legislation in the countries belonging to the European Union, the Customer cannot exercise this conventional warranty for

damage/defects that are unrelated to the production process such as, by way of example, any damage/defect deriving from:

- negligence in the execution of the Scheduled Maintenance Plan specified by Ducati in article 5 below;
- incorrect maintenance or repair operations carried out by parties other than the Ducati Authorised Dealers and/or Service Centres
- assembly of spare parts or accessories whose use is not approved by Ducati;
- failure to comply with the prescriptions for the use of the vehicle and its equipment as indicated in the Owner's Manual;
- modifications to the vehicle made by the Customer and / or third parties without the express approval of Ducati;
- Customer's failure to adhere to any recall campaigns planned by Ducati.

3.3 Procedure for claiming the warranty

3.1. To activate this warranty and maintain its validity, the Customer is required to:

- a) report any motorcycle defects to one of the Ducati Dealers and/or Authorised Service Centres listed on the website www.ducati.com

as soon as possible with respect to the time of their discovery, in order to reduce the consequences that such defects may have on the functionality and safety of the motorcycle.

- b) comply with the scheduled maintenance plan foreseen in art. 5 of these warranty conditions;
- 1) c) keep adequate documentation of any maintenance and/or repair work carried out on the vehicle (service booklet/receipts/invoices with details of the work carried out and the parts used). A copy of this documentation should be given to the Dealer/Authorised Service Centre from whom the warranty claim is made, who will be able to verify that the work has been carried out correctly.

3.2 For tracking purposes necessary for the implementation of safety and technical update policies in the event of a change of motorcycle ownership, the new owner must notify Ducati of the change of ownership advising the Ducati Customer Service at the contact information available at www.ducati.com or at the Ducati Authorised Dealers and/or Service Centres within thirty (30) days after change of ownership date.

4. Limitations of liability

4.1 Without prejudice to the national regulations applicable to the "consumer" and relating provisions on manufacturer liability, Ducati shall not be held liable in case of damage to people and/or property caused by the motorcycle or while using the same.

4.2 Any defects or delays in the repairs or replacements relating to the motorcycle caused by Ducati Authorised Dealers and/or Workshops shall not give the buyer the right to claim damages of any kind from Ducati, nor to extend the warranty per the present Warranty Conditions, without prejudice to the Customer's rights and actions with respect to the Ducati Authorised Dealer and/or Workshop that may be negligent/defaulting.

4.3 This warranty, under the conditions specified herein, is the only conventional warranty offered by Ducati, without prejudice to the possibility of extension through additional warranties offered by Ducati.

4.4 Ducati reserves the right to make changes and improvements to any model of its motorcycles, without the obligation to make said changes to motorcycles already sold.

4.5 These Warranty Conditions also extend to subsequent owners of the motorcycle, provided that

the provisions under art. 3 above are complied with. In any case, Ducati shall not be held liable for defects of the motorcycle attributable to the failure to notify Ducati of the change of ownership of the same.

4.6 Except as for the "consumer", or as otherwise provided by a mandatory regulation in force in the country of the Customer, the Court of Bologna (Italy) shall have sole jurisdiction over any controversies that may arise in connection with these Warranty Conditions.

4.7 These Warranty Conditions are governed by Italian law.

5. Scheduled maintenance plan and pre-delivery

5.1 The pre-delivery operations are carried out by the seller.

5.2 Ducati has defined the scheduled maintenance plan included in the "Owner's Manual" to keep their motorcycles at the best possible levels of efficiency, performance and safety.

5.3 Exact observance of the coupons, under the terms set forth herein, is a necessary condition to ensure the maintenance of the vehicle in correct usage status and the validity of this warranty. The following compulsory coupons must be carried out and paid for:

- first coupon: within six (6) months of delivery of the motorcycle to the Customer, or within the first 1000 km/600 miles travelled;
- second coupon, upon reaching the mileage specified in the maintenance schedule and in any case within twelve (12) months from previous service coupon.

Customer is solely liable for all costs related to coupons (labour and materials), including the one at 1,000 km /600 miles.

5.4 Every maintenance operation on the motorcycle must be carried out in compliance with Ducati's

recommendations and procedures, without limitations, including those reported in the "Owner's Manual". Any defect/damage to the vehicle caused by improper or insufficient maintenance will preclude the applicability of the warranty.

5.5 In order to certify that the operations specified for each service coupon have been duly performed, the Dealer and/or Authorised Ducati Service Centre shall place their stamp and write the necessary notes on the Service Booklet supplied with the motorcycle, and the customer shall preserve the receipts/ invoices for the service coupons that detail the operations performed. Warranty performance may be subject to the review of these documents by Ducati Technical Service.

If you purchased your motorbike in Australia or New Zealand



Attention

A reference to 'you' is a reference to the Customer.

If you purchased your motorbike in Australia:

Our goods come with guarantees that cannot be excluded under the Australian Consumer Law. You are entitled to a replacement or refund for a major failure and compensation for any other reasonably foreseeable loss or damage. You are also entitled to have the goods repaired or replaced if the goods fail to be of acceptable quality and the failure does not amount to a major failure.

If you purchased your motorbike in New Zealand:

Our goods come with guarantees that cannot be excluded under the Consumer Guarantees Act 1993. You are entitled to a replacement or refund for a failure of substantial character and compensation for any other reasonably foreseeable loss or damage. You are also entitled to have the goods repaired or replaced if the goods fail to be of acceptable quality and the failure does not amount to a failure of substantial character.

The benefits given to you by the warranty set out in this Owner's manual are in addition to any other rights and remedies you have under a law in relation to the motorcycle. If any provision of the general warranty conditions set out in this booklet should exclude or limit any rights under the Australian Consumer Law or the Consumer Guarantees Act 1993 (National Law), such provision is null and void. In circumstances where your rights under the National Law are greater than your rights under the Warranty, Ducati will honour your rights under the National Law.

To make a claim under the Warranty you must notify one of the Ducati Authorised Dealers and/or Workshops listed in the "Dealer Locator" (available at www.ducati.com) of any defects of the motorcycle within two (2) months of becoming aware of the defect. If you have any questions, you may contact Ducati ANZ Pty Ltd ACN 636 589 430 at Level 6, 895 South Dowling Street, Zetland NSW 2017 or by email at contact@ducati.com or by phone on 1300 11 26 06 (AU) / 0800 382 284 (NZ).

You must bear the expense of claiming under the Warranty.

General Information

Acronyms and abbreviations used in the Manual

ABS	Anti-lock Braking System
BBS	Black Box System
CAN	Controller Area Network
DDA+	Ducati Data Analyzer +
DPL	Ducati Power Launch
DQS	Ducati Quick Shift
DRL	Daytime Running Light
DSB	Dashboard
DSC	Ducati Slide Control
DTC	Ducati Traction Control
DWC	Ducati Wheelie Control
EBC	Ducati Engine Brake Control
ECU	Engine Control Unit
GPS	Global Positioning System

IMU	Inertial Measurement Unit
-----	---------------------------

Warning symbols used in the manual

Several kinds of warnings are used as an alert of the possible hazards for you or other persons such as:

- Safety labels on the motorcycle;
- Safety messages preceded by a warning symbol and either WARNING or IMPORTANT.



Attention

Failure to comply with these instructions may put you at risk, and could lead to severe injury or even death of the rider or other persons.



Important

Possibility of damaging the motorcycle and/or its components.



Note

Additional information about the current operation.

The terms RIGHT and LEFT are referred to the motorcycle viewed from the riding position.

Intended use

This motorcycle must be ridden on asphalt or on flat and even surfaces, only. This motorcycle may not be used for riding on dirt trails or for off-road riding.

Attention

Off-road riding may lead to loss of control and result in vehicle damage, personal injuries or even death.

Attention

This motorcycle may not be used to tow any trailers or with a side-car attached; this can lead to loss of control and result in an accident.

Attention

The total weight of the motorcycle in running order must not exceed 199 kg (438.72 lb).

Important

Using the motorcycle under extreme conditions, such as very damp and muddy roads or dusty and dry environment, could cause above-average wear of components like the drive system, the brakes or the air filter. If the air filter is dirty, the engine could get damaged. Therefore, this might translate in required service or replacement of the wear parts earlier than specified in the scheduled maintenance chart.

Rider's obligations

All riders must hold a valid licence.

Attention

Riding without a licence is illegal and is prosecuted by law. Always make sure you have your licence with you when riding. Do not let inexperienced riders or persons without a valid licence use your motorcycle.

Do not ride under the influence of alcohol and/or drugs.

Attention

Riding under the influence of alcohol and/or drugs is illegal and is prosecuted by law.

Do not take prescription or other drugs before riding unless you have consulted your doctor about their side effects.

Attention

Some medications and drugs may cause drowsiness or other effects that slow down reaction time and the rider's ability to control the motorcycle, possibly leading to an accident.

Some states require vehicle insurance.

Attention

Check your state laws. Obtain insurance coverage and keep your insurance document secure with the other motorcycle documents.

To protect rider and passenger safety, some states mandate the use of a certified helmet.

Attention

Check your state laws. Riding without a helmet may be punishable by law.

Attention

Riders without helmets are more likely to suffer severe bodily injury or die if they are in an accident.

Attention

Check that your helmet complies with safety specifications, permits good vision, is the right size for your head, and carries a certification label indicating that it conforms to the standards in force in your state. Road traffic laws differ from state to state. Learn about traffic laws in your state before riding and always obey them.

Rider's training

Accidents are frequently due to inexperience. Riding, manoeuvres and braking must be performed in a different way than on the other vehicles.

Attention

Untrained riders or a wrong use of the vehicle may lead to loss of control, serious injuries or even death.

Apparel

Riding gear is very important for safety. Unlike cars, a motorcycle offers no impact protection in an accident.

Proper riding gear includes helmet, eye protection, gloves, boots, back protector, long sleeve jacket and long trousers.

- The helmet must meet the requirements listed at "Rider's obligations"; if your helmet does not have a visor, use suitable eye wear;
- Use certified, five-finger gloves made from leather or abrasion-resistant material; with knuckle protectors and reinforcements on the fingers;
- Riding boots or shoes must have non-slip soles and offer ankle protection;
- The back protector must be certified and sized based on the physical constitution of the rider, according to the manufacturer's specifications;
- Jacket, trousers or riding suit must be certified, made from leather or abrasion-resistant material and have high-visibility colours and inserts. Select products with certified protectors.



Important

Never wear loose clothing, items or accessories that may become tangled in motorcycle parts.



Important

For your safety, always wear suitable protective gear, regardless of season and weather.



Important

Have your passenger wear proper protective clothing.

"Safety ""Best Practices"""

These few simple operations are critical to people safety and to preserving the full performance of your motorcycle. Never forget to perform them before, while and after riding.



Important

Closely follow the indications provided at chapter "Riding the motorcycle" during the running-in period.

Failure to follow these instructions releases Ducati Motor Holding S.p.A. from any liability whatsoever for any engine damage or shorter engine life.



Attention

Before riding your motorcycle, become familiar with the controls you will need to use when riding.

These few simple operations are critical to people safety and to preserving the full performance of your motorcycle. Never forget to perform them before, while and after riding.

Perform the checks recommended in this manual under "Checks before riding" before each ride.

 **Attention**

Failure to carry out these checks before riding may lead to motorcycle damage and injury to rider and/or passenger.

 **Attention**

Start the engine outdoors or in a well ventilated area. The engine should never be started or run indoors.

Exhaust gases are poisonous and may lead to loss of consciousness or even death within a short time. Use proper body position while riding and ensure your passenger does the same.

 **Important**

Rider must hold the handlebar with both hands at ALL TIMES while riding.

 **Important**

Both rider and passenger should keep their feet on the footpegs when the motorcycle is in motion.

 **Important**

The passenger should always hold on to the grab handles under the seat with both hands.

 **Important**

Be very careful when tackling road junctions, or when riding in areas near exits from private grounds, car parks or on slip roads to access motorways.

 **Important**

Be sure you are clearly visible and do not ride within the blind spot of vehicles ahead.

 **Important**

ALWAYS signal your intention to turn or pull to the next lane in good time using the suitable turn indicators.

 **Important**

Park your motorcycle where no one is likely to knock against it, and use the side stand. Never park on uneven or soft ground, or your motorcycle may fall over.



Important

Visually inspect the tyres at regular intervals for detecting cracks and cuts, especially on the side walls, bulges or large spots that are indicative of internal damage. Replace them if badly damaged. Remove any stones or other foreign bodies caught in the tread.



Attention

Engine, exhaust pipes and silencers stay hot long after the engine is switched off; pay particular attention not to touch the exhaust system with any body part and do not park the vehicle next to flammable material (wood, leaves etc.). Do not cover the motorbike with the canvas, when the engine and exhaust system are hot, to avoid damaging it.

Refuelling

Fuel label

Fuel identification label

Refuel outdoors with engine off.

Do not smoke or use open flames while refuelling. Be careful not to spill fuel on engine or exhaust pipe. Never completely fill the tank when refuelling. Fuel should never be touching the rim of filler recess.

When refuelling, avoid breathing the fuel vapours and prevent fuel from reaching your eyes, skin or clothes.

Attention

The motorcycle is only compatible with fuel having a maximum content of ethanol of 10% (E10). Using fuel with ethanol content over 10% is forbidden. Using it could result in severe damage of the engine and motorcycle components. Using fuel with ethanol content over 10% will make the warranty null and void.

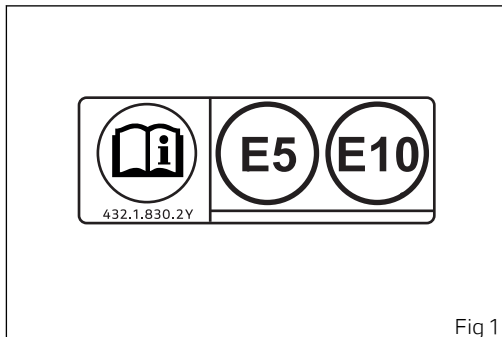

Fig 1

Attention

In case of indisposition caused by breathing fuel vapours for a long time, stay in the open air and contact your doctor. In case of contact with eyes, thoroughly flush with water; in case of contact with skin, immediately clean with water and soap.

Attention

Fuel is highly flammable, in case of accidental spillage of fuel on your clothes it is necessary to change into clean clothes.

Carrying the maximum load allowed

Your motorcycle is designed for long-distance riding, carrying the maximum load allowed in full safety. Even weight distribution is critical to preserving these safety features and avoiding trouble when performing sudden manoeuvres or riding on bumpy roads.

Attention

Do not exceed the total permitted weight for the motorcycle and pay attention to information provided below regarding load capacity.

Information about carrying capacity

Important

Arrange your luggage or heavy accessories in the lowest possible position and close to motorcycle centre.

Important

Never fix bulky or heavy objects to the handlebar or to the front mudguard as this would affect stability and cause danger.

Important

Be sure to secure the luggage to the supports provided on the motorcycle as firmly as possible. Improperly secured luggage may affect stability.

Important

Do not insert any objects you may need to carry into the gaps of the frame as these may foul moving parts.

Attention

Make sure the tyres are inflated to the proper pressure and that they are in good condition.

Refer to paragraph "Tubeless tyres".

Dangerous products - warnings

Used engine oil

Attention

Prolonged or repeated contact with used engine oil may cause skin cancer. If working with engine oil on a daily basis, we recommend washing your hands thoroughly with soap immediately afterwards. Keep away from children.

Brake dust

Never clean the brake assembly using compressed air or a dry brush.

Brake fluid

Attention

The fluid used in the brake system is corrosive. In the event of accidental contact with eyes or skin, wash the affected area with abundant running water.

Attention

Spilling brake fluid onto plastic, rubber or painted parts of the motorcycle may cause damages. Protect these parts with a clean shop cloth before proceeding to service the system. Keep away from children.

Coolant

Engine coolant contains ethylene glycol, which may ignite under particular conditions, producing invisible flames. Although the flames from burning ethylene glycol are not visible, they are still capable of causing severe burns.

Attention

Take care not to spill engine coolant on the exhaust system or engine parts.

These parts may be hot and ignite the coolant, which will subsequently burn with invisible flames. Coolant (ethylene glycol) is irritant and poisonous when ingested. Keep away from children. Never remove the radiator cap when the engine is hot. The coolant is under pressure and will cause severe burns.

The cooling fan operates automatically: keep hands well clear and make sure your clothing does not snag on the fan.

Battery



Attention

The battery gives off explosive gases; never cause sparks or allow naked flames and cigarettes near the battery. When charging the battery, ensure that the working area is properly ventilated and that ambient temperature is below 40° C (104° F). Never try to open the battery: it does not need to be filled with acid or other types of fluids.

Vehicle identification number



Note

These numbers identify the motorcycle model and should always be indicated when ordering spare parts.

The frame identification number is on the motorcycle front right side, more specifically, close to the right fork leg and to the water expansion reservoir.

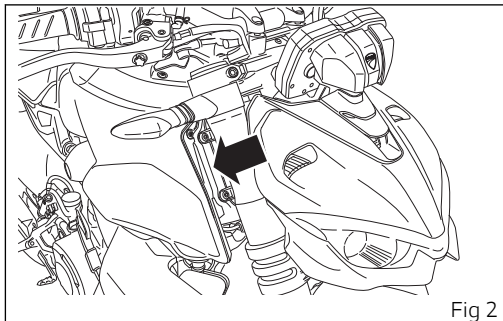

Fig 2

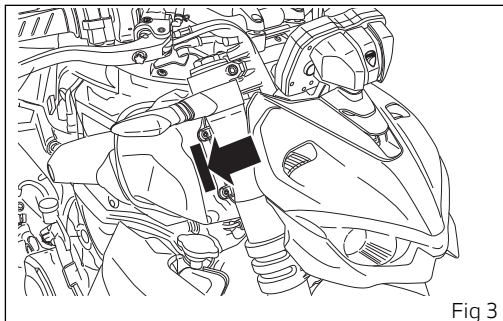

Fig 3

Engine identification number

Note

These numbers identify the motorcycle model and should always be indicated when ordering spare parts.

The engine identification number is located in the motorcycle front left side on the horizontal head cylinder lower side, near the generator cover and the canister filter.

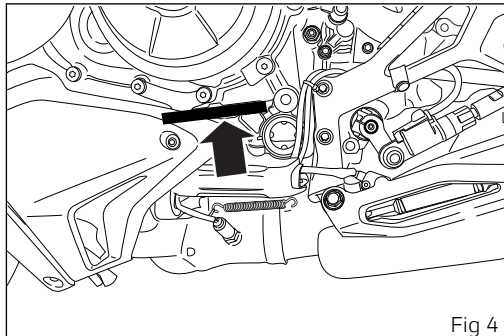

Fig 4

Main components and devices

Position on the vehicle

- 1) Tank filler plug.
- 2) Seat lock.
- 3) Side stand.
- 4) Rear-view mirrors.
- 5) Front fork adjusters.
- 6) Rear shock absorber adjusters.
- 7) Catalytic converter (both sides).
- 8) Exhaust silencer (both sides).

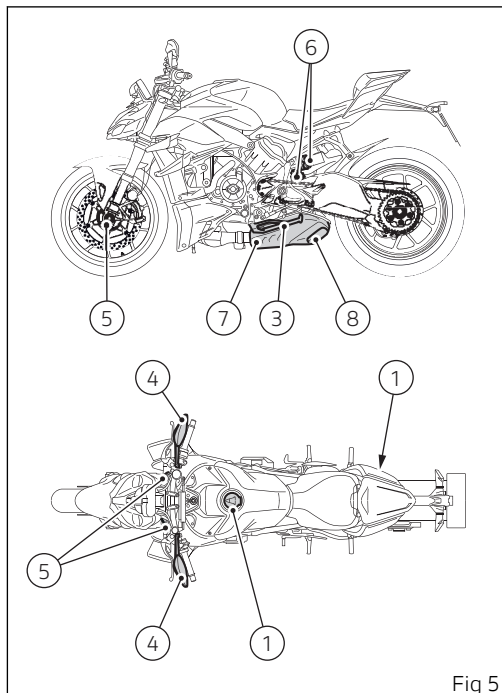

Fig 5

Tank filler plug

Opening

- Lift flap (1) and insert the key in the lock;
- Turn the key clockwise by 1/4 of a turn to release the lock;
- Lift the fuel tank plug (2).

Closing

- Close the plug (2) with the key inserted and push it down into its seat;
- Remove the key and close flap (1) protecting the lock.

Note

Plug can only be closed when key is inserted.

Attention

After refuelling, always make sure that the plug is perfectly in place and closed.

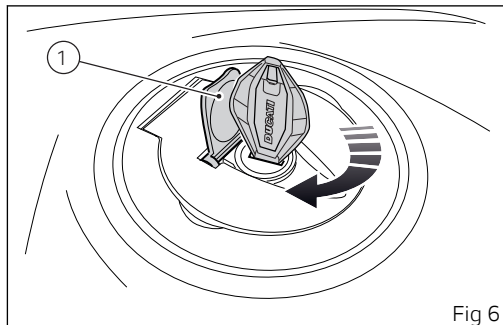

Fig 6

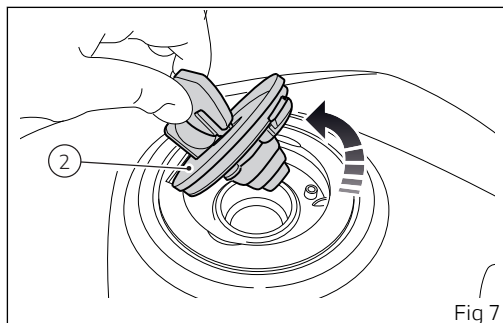

Fig 7

Removing and refitting the seats

Use lock (1) to remove the passenger seat (2) and reach the tail guard compartment.

Removing the passenger seat

- Insert the key into the lock (1);
- Turn the key counter clockwise until the passenger seat (2) catch disengages with an audible click;
- Pull the passenger seat (2) towards the front end of the vehicle until releasing it.

Refitting the passenger seat

- Before refitting the passenger seat (2), make sure that passenger strap (3) is correctly positioned.
- Slide the passenger seat (2) from vehicle front (A) end towards the rear end (B) until hearing the catch click into place.

Attention

To close the seat cover insert it from the motorcycle side and slide it towards the rear side until hearing the engagement click.

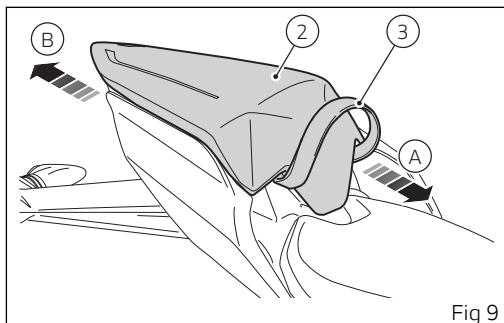
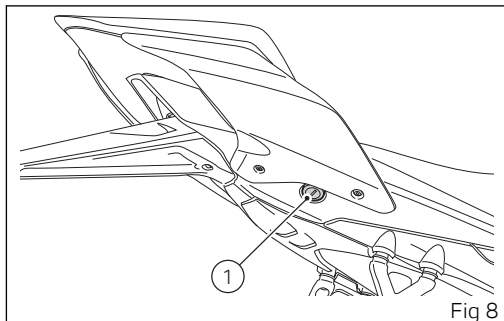

Removing the rider seat

- Using the Allen wrench present in the tail guard compartment, loosen the two screws (4) on both sides of the rider seat (5);
- Slide the seat towards the rear end of the vehicle.

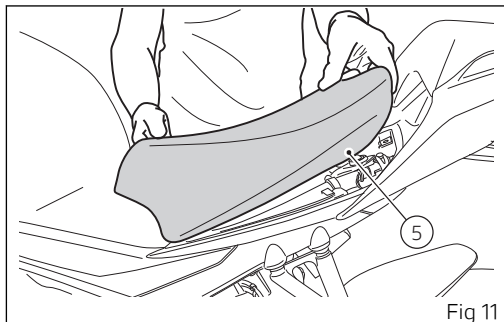
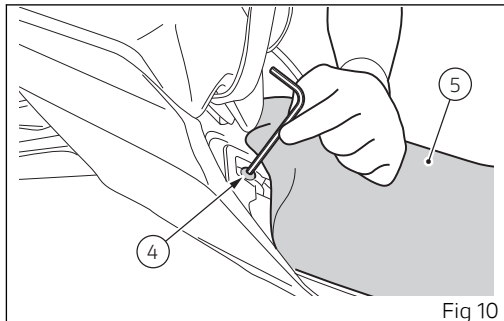

Refitting the rider seat

- Refit the rider seat (5) by first inserting the brackets of seat (6) in the frame (7) brackets and then placing the rear part of the seat on the frame;
- Lift the rear edges of the seat (5) and fasten it by tightening screws (4) (Fig 10);
- Check proper rider seat fastening by trying to raise its front end.

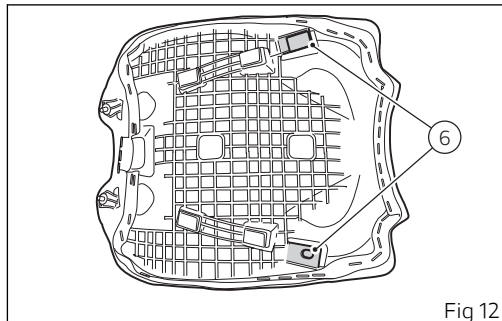

Fig 12

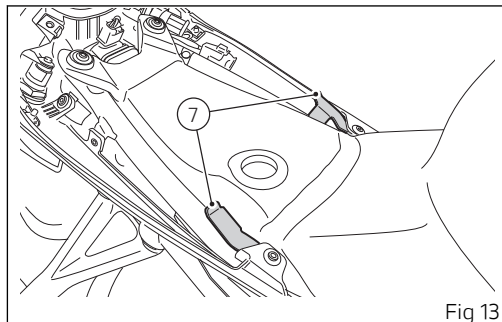

Fig 13

With the seats removed, the connector (6) for the battery maintainer is accessible. To use it, slide it out and connect it to maintainer (7), as described in chapter "Maintaining the battery charge".

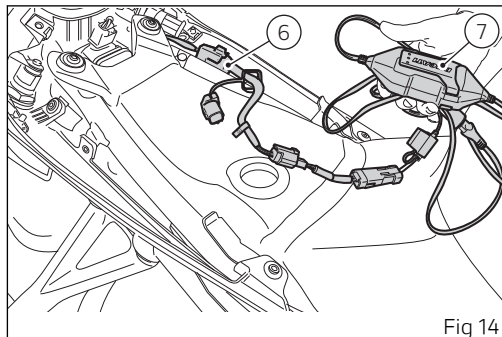

Fig 14

Maintaining the battery charge

Your motorcycle is equipped with a connector (1), under the rider seat, to which you can connect a special battery charger (2) (Battery charge maintenance kit part no. 69928471A (Europe), part no. 69928471AW (Japan), 69928471AX (Australia), 69928471AY (UK), 69928471AZ (USA), available from our sales network.

Remove the connector (1) and connect it to the maintainer (2).

Note

The electric system of this model is designed so as to ensure there is a very low power drain when the motorcycle is OFF. Nevertheless, the battery features a certain self-discharge rate that is normal and depends on ambient conditions as well as on "non-use" time.

Important

If battery is not kept at a minimum charge level by a suitable battery charge maintainer, sulphation may occur and this is an irreversible phenomenon causing decreasing battery performance.

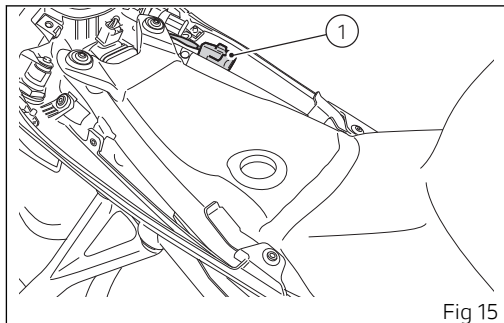

Fig 15

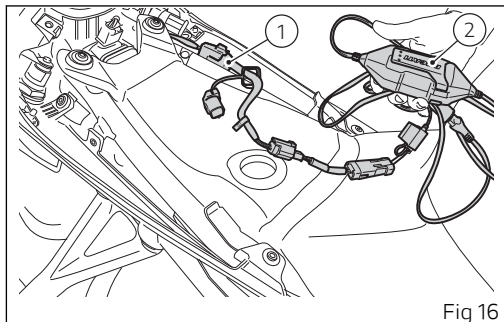

Fig 16

When the motorcycle is left unused (approximately for more than 30 days). We recommend owners to use the Ducati battery charge maintainer (Battery maintenance kit) since its electronics monitors the battery voltage and features a maximum charge current of 1.5 Ah. Connect the battery maintainer to the diagnostic socket.

Note

Using charge maintainers not approved by Ducati could damage the electric system; motorcycle warranty does not cover the battery if damaged due to failure to comply with the above indications, since it is considered as wrong maintenance.

Attention

NEVER connect the battery in parallel with that of other vehicles, as this may cause a short circuit or overheating of the battery.

Side stand

Important

Place the motorcycle on the side stand only when you are not going to use it for short periods of time. Before lowering the side stand, make sure that the bearing surface is hard and flat.

Do not park on soft or pebbled ground or on asphalt melted by the sun, etc. or else the motorcycle may fall over. When parking downhill, always position the motorcycle with the rear wheel facing downhill.

To pull down the side stand, hold the motorcycle handlebars with both hands and push down on the side stand (1) with your foot until it is fully extended. Tilt the motorcycle until the side stand is resting on the ground.

To easily find the side stand during the opening phase, press on pin (3) with your foot.

Attention

When using the bike on the track, we recommend removing the pin (3) by working on the key (4).

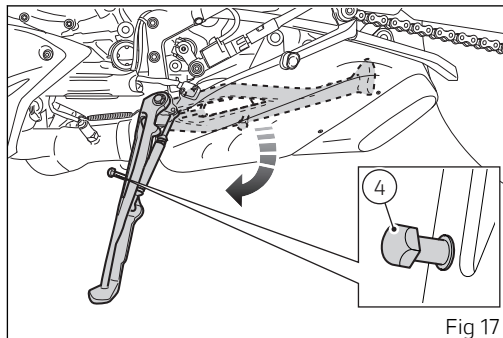

Fig 17

To move the side stand to its rest position (horizontal position), lean the motorcycle to the right while lifting the thrust arm (1) with your foot.

To ensure trouble-free operation of the side stand joint, thoroughly clean it and then use SHELL Alvania R3 grease to lubricate all friction points.

Attention

Do not sit on the motorcycle when it is supported on the side stand.

 **Note**

Check for proper operation of the stand mechanism (two springs, one into the other) and the safety sensor (2) at regular intervals.

 **Note**

The engine can be started with the side stand down and the gearbox in neutral. If starting with a gear engaged, pull in the clutch lever (in this case the side stand must be up).

Bluetooth control unit

The motorcycle can be equipped with a Bluetooth control unit that works as a hub between the various supported electronic devices relying on a Bluetooth communication interface.

The Bluetooth control unit, which is not installed in this vehicle, can be purchased at a Ducati Dealer or Authorised Service Centre.

Attention

Smartphone and Bluetooth Headset device manufacturers may incorporate certain changes within the standard protocols over the course of the lifecycle of the device (Smartphones and Earphones).

Attention

These changes are outside the control of Ducati and may result in Bluetooth Headset devices functionality becoming impaired (sharing Music, multimedia player, etc.) and may equally affect some types of Smartphones (depending on supported Bluetooth profiles). This is why Ducati cannot guarantee multimedia player proper operation for:

- any earphones not coming with the "Ducati Kit part no. 981029498";
- any Smartphones not supporting the required Bluetooth profiles (even though paired to earphones coming with the "Ducati Kit part no. 981029498").

Attention

In case of interference or noise due to particular conditions of the external environment, the Ducati earphone kit part no. 981029498 also allows sharing the music being played directly from rider helmet to passenger helmet (for further details please refer to the manual of the earphones coming with the Ducati kit part no. 981029498).

 **Note**

The Ducati kit part no. 981029498 can be purchased separately at a Ducati Dealer or Authorised Service Centre.

Check that your Smartphone supports the following profiles:

- MAP profile: for a correct display of SMS and MMS notifications;
- PBAP profile: for a correct display of the Smartphone contact list.

 **Attention**

Ducati does not ensure a correct connection to the Ducati Multimedia System of Bluetooth navigators that are not provided in the following kits:

- Kit of Ducati Zumo satellite navigator 350
- Kit of Ducati Zumo satellite navigator 390
- Kit of Ducati Zumo satellite navigator 395

 **Note**

The Ducati kits mentioned above can be purchased separately at a Ducati Dealer or Authorised Service Centre.

Steering damper

It is located before the handlebar and is secured to the steering head.

It provides stable and accurate steering, improving the motorcycle's handling response under any conditions.

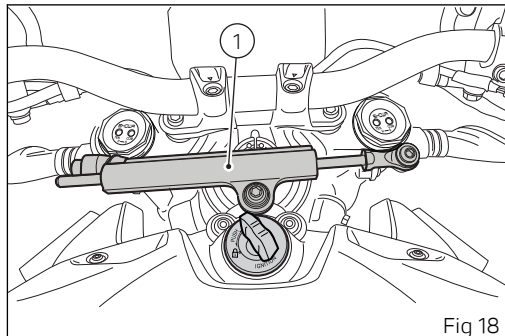

Fig 18

Front fork adjustment

The front fork used on this motorcycle has rebound (return), compression and spring preload adjustment.

Adjustment is done by external screw adjusters.

- 1) For rebound adjustment (1);
- 2) for compression adjustment (2);
- 3) for inner spring preload adjustment (3).

Position the motorcycle on its side stand so that it is stable.

Turn the adjuster (1) at the top end of each fork leg with a flat screwdriver to adjust rebound damping.

Turn the adjuster (2) at the top end of each fork leg with a flat screwdriver to adjust compression damping.

Turn the adjusting screws (1) and (2) to adjust the damping. The stiffest damping setting is obtained with the adjuster turned fully clockwise to the "0" position. Starting from this position, turning counter clockwise, you can count the turns.

To change preload of the spring inside each fork leg, turn the hex. adjuster (3), with a hexagon wrench, starting from the fully open (clockwise) position.

STANDARD settings are as follows:

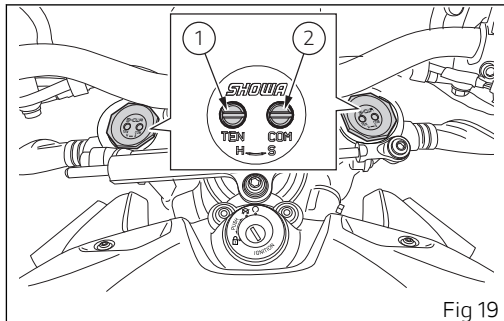

Fig 19

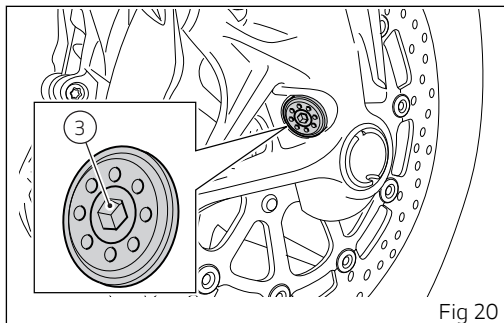

Fig 20

compression: Max – 7 turns (from fully closed);
rebound: Max – 5.5 turns (from fully closed);
spring preload: 7 turns (from fully open).

The settings for the use on the track are as follows:

compression: Max – 1 turns (from fully closed);
rebound: Max – 4 turns (from fully closed);
spring preload: Max 9 turns (from fully open).



Attention

Adjust both fork legs to same settings.

Adjusting the rear shock absorber

The rear shock absorber has adjusters that enable you to suit the setting to the load on the motorcycle. Adjuster (1), located on the lower part of the monoshock, adjusts the damping during the rebound phase (return).

The adjuster (2) located on the expansion reservoir of the shock absorber adjusts the hydraulic compression damping.

The ring nuts (3) allow adjusting the shock absorber external spring preload.

To adjust the spring preload, loosen the top ring nut. Then **TIGHTEN** or **SLACKEN** the lower ring nut to **INCREASE** or **DECREASE** spring preload. After setting spring preload as desired, tighten the upper locking ring nut.

STANDARD setting: from the fully closed position (clockwise), loosen as follows:
rebound (1): 6 clicks from fully closed;
compression (2): 1.5 turns from fully closed;
spring preload: 14 mm (0.55 in) from fully uncompressed spring.

On the track; from the fully closed position (clockwise) unscrew:
rebound (1): 4 clicks from fully closed;

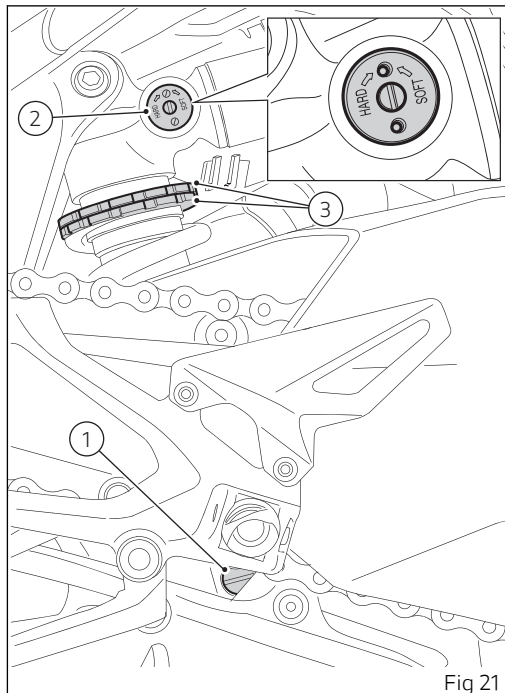

Fig 21

compression (2): 0.5 turns from fully closed;
spring preload: 18 mm (0.71 in) from fully
uncompressed spring.



Attention

The shock absorber is filled with gas under pressure and may cause severe damage if taken apart by unskilled persons.

When carrying a passenger and luggage, set the rear shock absorber spring to proper preload to improve motorcycle handling and keep safe clearance from the ground. You may find that rebound damping needs adjusting as well.

Standard settings of the vehicle as delivered (factory settings specified in the previous paragraphs) correspond to a calibration which considers all use conditions (riding conditions, rider's skills and needs), and is the best solution for a sport use of the motorcycle on the road.

Controls

Position of motorcycle controls

Attention

This section shows the position and function of the controls used to ride the motorcycle. Be sure to read this information carefully before you use the controls.

- 1) Instrument panel.
- 2) Key-operated ignition switch and steering lock.
- 3) Left-hand switch.
- 4) Clutch lever.
- 5) Right-hand switch.
- 6) Throttle twistgrip.
- 7) Front brake lever.
- 8) Rear brake pedal.
- 9) Gear change pedal.

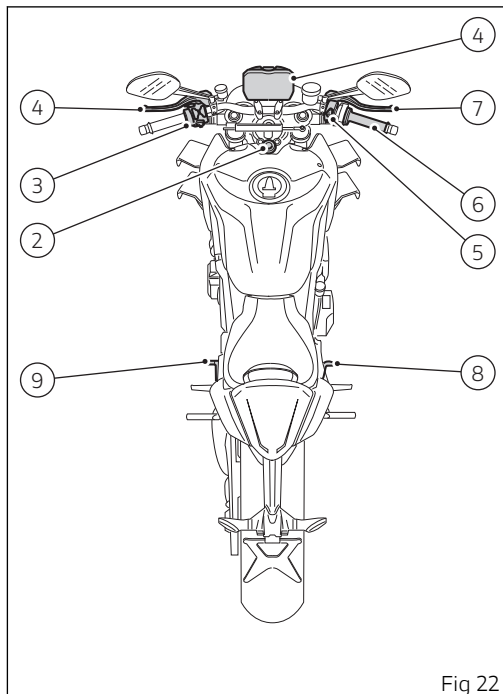
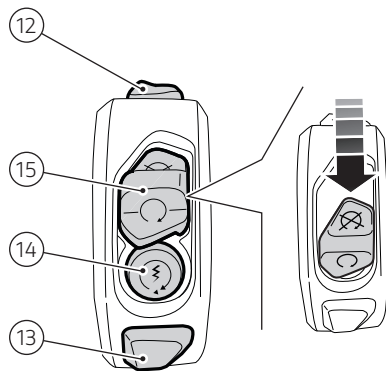
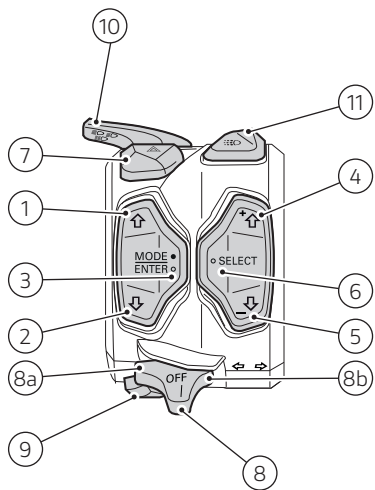















Fig 22

Switchgears



1		Control button up
2		Control button down
3		Button for Riding Mode change and ENTER function
4		Quick selection button +
5		Quick selection button –
6		Quick selection button “SELECT”
7		Hazard lights (red)
8		3-position turn indicator control: <ul style="list-style-type: none"> ● position (8a), left turn indicator ● centre position, OFF ● position (8b), right turn indicator
9		Warning horn
10		Light selector: <ul style="list-style-type: none"> ● high beam, pushed up ● low beam, at the centre ● high-beam flasher and “Start/Stop Lap” function, pushed down
11		DRL (if present)
12		Heated handgrips (if any)
13	DPL	Assisted start (DPL - Ducati Power Launch)

14		Engine start
15		Engine kill, pushed down (red)

Light control

Low / High beam

At Key-On, the high beam and low beam lights are off; only the parking lights are turned on.

When the engine is started the low beam is automatically switched on. It is possible to switch from low to high beam and vice versa with button (3), positions (A) and (B), or flash by pressing button (3) in position (C). If engine is not started after turning the key to on, it is nevertheless possible to switch on the lights or flash.

If within 60 seconds from the manual switching on of the low or high beam the engine is not started, the lights are turned off.

To preserve the motorcycle battery, if when starting the engine the high/low beams are on, the headlight is automatically switched off and then on again when the engine is started.

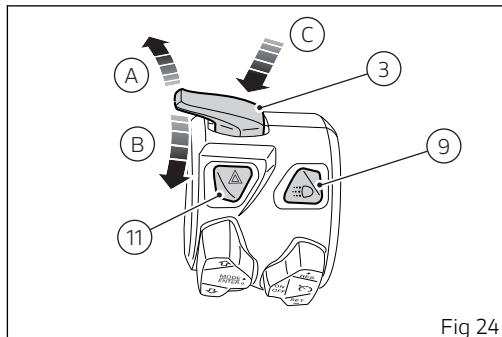

Fig 24

DRL in "Auto" mode – only for version with DRL lights

If the DRL was set to "Auto" via the "DRL" function within the SETTING MENU (see "SETTING MENU - DRL"), the instrument panel automatically manages the DRL and the low beam according to detected ambient light:

- if the instrument panel detects good light conditions (day) the DRL is turned on and the low beam is turned off;
- if the instrument panel detects poor light conditions (night) the DRL is turned off and the low beam is turned on.

When the DRL is set to AUTO mode, the display shows the warning light indicated in the figure. If the DRL was set to "Auto" mode, press button (9) to disable that mode and set manual light management. Press again button (9) re-enable DRL but with control strategy set to "Manual". In this case, upon next Key-On, DRL will be again set to "Auto" mode.

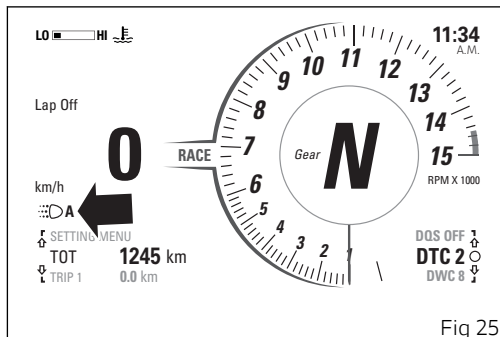

Attention Using the DRL light in "Auto" mode in case of poor light conditions, especially in case of fog or clouds, could impair safety. In this case Ducati recommends to manually activate the low beam.

DRL in "Manual" mode – only for version with DRL lights

If the DRL lights are in this mode, as set through the "DRL" function within the SETTING MENU, DRL lights will not change their status upon key-on. To switch on or off the DRL lights, it is necessary to press button (9).



Attention

Using the DRL lights in poor light conditions (dark) could compromise the riding visibility and dazzle anyone coming on the opposite lane.



Note

Using the DRL lights during the day improves visibility compared to low beam.

Turn indicators

Turn indicators are automatically reset by the instrument panel.

To activate the left turn indicators, press button (10) in position (I); to activate the right turn indicators, press button (10) in position (L).

Turn indicators can be cancelled by pressing button (10) on LH switch.

Automatic switch-off:

The turn indicators switch off automatically after the turn, as calculated based on vehicle speed, lean angle and in general according to the analysis of vehicle dynamic conditions.

This means that automatic switch-off is triggered when vehicle speed exceeds 20 km/h (12.4 mph) after the turn indicator button was pressed.

Turn indicators also switch off automatically if they remained on for a long mileage (which can range between 200 and -2000 metres (656-6562 feet), depending on vehicle speed when the turn indicator button was pressed.

If the turn indicator switch is again operated, while turn indicator is still on, automatic switch-off feature is re-initialised.

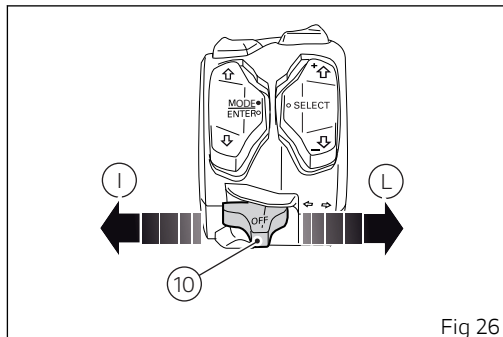

Fig 26

The automatic switch-off system can be disabled in the Setting menu.



Attention

The automatic deactivation systems are assist systems helping the rider control the turn indicators in the most comfortable and easy way. Such systems have been designed to work in most riding manoeuvres, nonetheless the rider must pay attention to the turn indicator operation (disabling or enabling them by hand if needed).

Hazard function (4 turn indicators)

The "Hazard" function turns all four turn indicators on at the same time to signal an emergency condition. Push button (11, Fig 24) to activate the "Hazard" function. It can only be activated when vehicle is turned on (Key-ON). When the "Hazard" function is active, all four turn indicators blink at the same time as well as warning lights on the instrument panel. The "Hazard" function can be manually turned off exclusively when vehicle is on (Key-ON), by pressing button (11, Fig 24).

Once the "Hazard" function is activated, if vehicle is turned off (key turned to "OFF"), the function stays active for 2 hours. After 2 hours, the turn indicators switch OFF automatically in order to save battery charge.

Note

If user performs a Key-ON while the "Hazard" function is still active, the function will remain ON (temporary turn indicator control interruption is allowed during the instrument panel initial check routine).

Note

If there is a sudden interruption in the battery while the function is active, the instrument panel will disable the function when the voltage is restored.

Note

The "Hazard" function has higher priority compared to normal operation of the single turn indicators, this means that, as long as it is active, it will not be possible to activate the single right or left turn indicators.

Parking lights

When turning the key to off, the display shows the page where to switch on the parking lights: to turn on the parking lights, keep pressed button (10, Fig 26) in position (I).



**Keep the turn signal switch
on the left position
to activate the Parking Light**

Fig 27

Keys

The motorcycle comes with 2 keys.
They contain the "Immobilizer system code".
The keys are those for the standard use, i.e. to:

- start the engine;
- open the fuel tank plug;
- open the seat lock.

Attention

Separate the keys and use only one of the two to ride the bike.

Duplicate keys

When a customer needs spare keys, he/she shall contact a Ducati authorised service centre and bring all keys he/she still has. The Ducati authorised service centre will program all new and old keys. The Ducati authorised service centre may ask to the customer to prove to be the motorcycle owner. The codes of the keys missing during the programming procedure will be erased to ensure that any lost key can not start the engine.

Note

If the motorcycle owner changes, it is necessary that the new owner is given all keys.

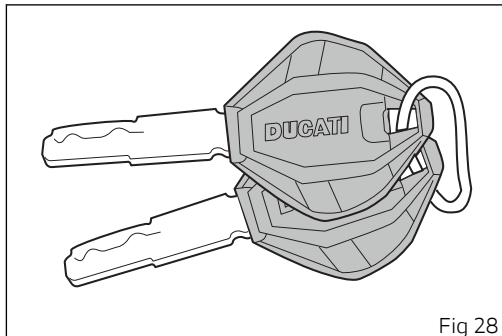

Fig 28

Immobilizer system

To further improve the anti-theft protection, the motorcycle is equipped with an engine electronic block system (IMMOBILIZER) that is automatically activated every time the instrument panel is switched off.

Inside of each key handgrip there is an electronic device that modulates the signal sent by a special antenna integrated in the ignition switch upon starting.

Such modulated signal represents the "password", that changes upon every starting, that allows the

control unit to acknowledge the key and thus starting the engine.

Ignition switch and steering lock

It is located in front of the fuel tank and has three positions:

- A) ON: enables lights and engine operation;
- B) OFF: disables lights and engine operation;
- C) LOCK: the steering is locked:



Attention

To move the key to the last position, press it down before turning it. The key can be removed in positions (B) and (C).

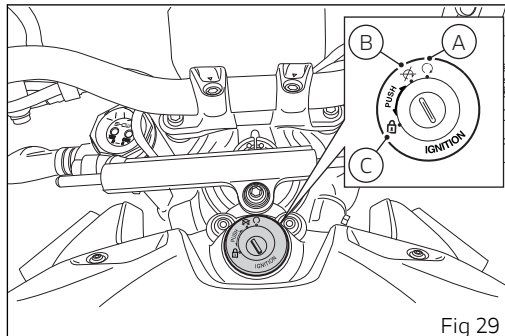

Fig 29

Restoring motorcycle operation via the PIN code

In case of key acknowledgement system or key malfunction, the instrument panel allows the user to enter his/her own PIN code to temporarily restore motorcycle operation.

if the Pin Code function is active, the instrument panel displays "Insert Pin" with four spaces allowing the rider to enter digits of the Pin code to be entered: "0" and "- - -".

Entering the code:

- use UP and DOWN buttons to increase and decrease by 1 the value from "0" to "9";
- press ENTER button to confirm the digit and move on to the following digit;
- repeat the procedure until entering all 4 digits.

Once the fourth digit is set, press ENTER and the instrument panel behaviour will be as follows:

- if there is a problem during the pin check, the instrument panel displays "Error" for 2 seconds and then passes to the standard screen.
- if the pin code is not correct, the instrument panel displays "Wrong" for 2 seconds and then

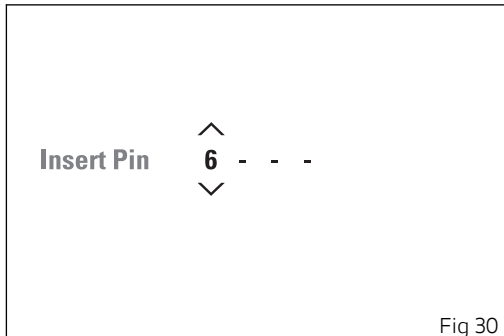

goes back to previous screen, to allow you to try again.

- if the pin code is correct, the instrument panel shows "Correct" for 2 seconds, and then displays the standard screen.



Important

If this procedure is necessary in order to start the motorcycle, contact an Authorised Ducati Service Centre as soon as possible to fix the problem.

Clutch lever

Lever (1) disengages the clutch. It features a dial adjuster (2) for lever distance from the twistgrip on handlebar.

The lever distance can be adjusted through 9 clicks of the dial (2).

Turn clockwise to increase lever distance from the handgrip.

Turn the adjuster counter clockwise to decrease lever distance.

When the clutch lever (1) is operated, drive from the engine to the gearbox and the drive wheel is disengaged.

Using the clutch properly is essential to smooth riding, especially when moving OFF.

Attention

Set clutch lever when motorcycle is stopped.

Important

Using the clutch properly will avoid damage to transmission parts and spare the engine.

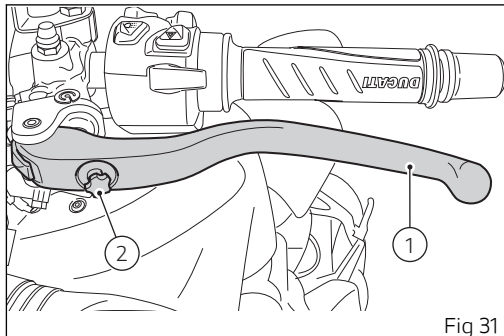

Fig 31



Note

The engine can be started with the side stand down and the gearbox in neutral. If starting with a gear engaged, pull in the clutch lever (in this case the side stand must be up before engaging the gear).

Throttle twistgrip

The twistgrip (1) on the right handlebar opens the throttles.

When released, it will spring back to the initial position (idling speed).

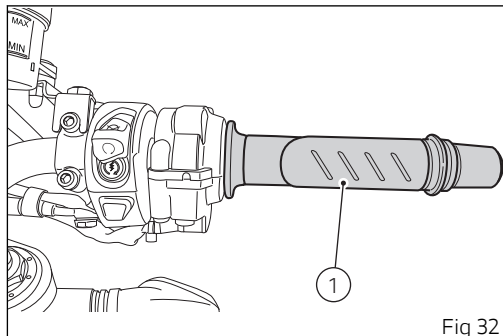

Fig 32

Front brake lever

Setting

Pull in the lever (1) towards the twistgrip to operate the front brake. The system is hydraulically operated and you just need to pull the lever gently.

The control lever (1) has a dial (2) for adjusting the distance between lever and twistgrip on the handlebar.

The lever distance can be adjusted through 9 clicks of the dial (2). Turn clockwise to increase lever distance from the twistgrip. Turn the adjuster counter clockwise to decrease lever distance.

Attention

Before using these controls, thoroughly read instructions under paragraph "Moving off".

Attention

Set front brake lever when motorcycle is stopped.

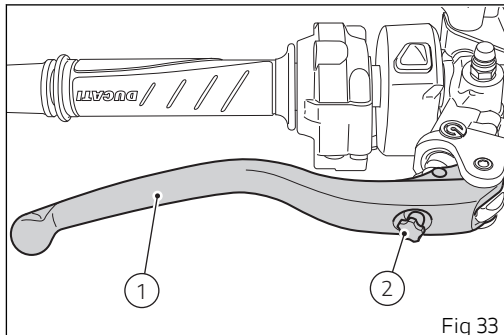

Fig 33

Rear brake pedal

Press pedal (1) down with your foot to operate the rear brake.

The control system is of the hydraulic type.

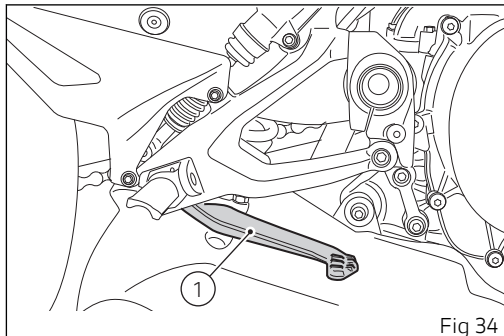

Fig 34

Gear change pedal

When released, the gear change pedal (1) automatically returns to rest position N in the centre. This is indicated by the instrument panel light N coming on.

The pedal can be moved:

- down = press down the pedal to engage the 1st gear and to shift down. The N light on the instrument panel will go out;
- upwards= lift the pedal to engage 2nd gear and then 3rd, 4th, 5th and 6th gears.

Each time you move the pedal you will engage the next gear.

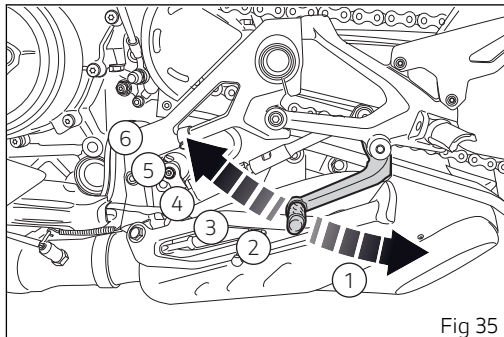

Fig 35

Adjusting the position of the gearchange pedal and rear brake pedal



Note

Gear change pedal position can be adjusted with respect to the motorcycle: please contact a Dealer or Ducati authorised service centre to have this adjustment performed.

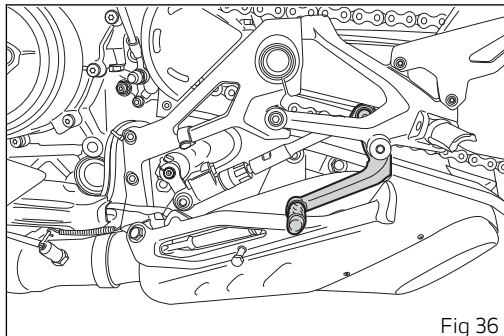

Fig 36

Riding the motorcycle

Running-in recommendations

Maximum rotation speed

Rotation speed for running-in period and during standard use (rpm):

- 1) Up to 621 mi (1000 km);
- 2) From 1000 km (621 mi) to 2500 km (1553 mi).

Up to 1,000 Km (621 mi)

During the first 1000 km (621.37 mi), keep an eye on the rev counter. It should never exceed: 5,500÷ (included) 6,000 rpm.

During the first hours of riding, it is advisable to run the engine at varying load and rpm, though still within recommended limit.

To this end, roads with plenty of bends and even slightly hilly areas are ideal for a most efficient running-in of engine, brakes and suspensions.

For the first 100 km (62 mi) use the brakes gently. Avoid sudden or prolonged braking. This will allow the friction material on the brake pads to bed in against the brake discs.

So that the mechanical parts of the motorcycle can adapt to each another, and especially so the life of the basic engine parts is not affected, avoid harsh accelerations and do not run the engine at a high rpm for an extended time, especially uphill. Furthermore, the drive chain should be inspected frequently. Lubricate as required.



Important

During the first 1000 km (621 mi) (Running-in period), i.e. when the Odometer displays a value <= (lower than or equal to) 1000 km (621 mi), the pre-warning area, indicated in orange (Orange area), both for the bargraph filling and the display of the relevant number, is displayed when reaching 6000 rpm. During the running-in period we recommend not to exceed 6000 rpm, thus the instrument panel will not display the bargraph "Orange area".

Pre-ride checks

Attention

Failure to carry out these checks before riding, may lead to motorcycle damage and injury to rider.

Before riding, perform a thorough check-up on your motorcycle as follows:

- **FUEL LEVEL IN THE TANK**
Check the fuel level in the tank. Refuel if necessary (see "Refuelling").
- **ENGINE OIL LEVEL**
Check the level in the sump through the sight glass; top-up if necessary (see "Checking the engine oil level").
- **BRAKE AND CLUTCH FLUID**
Check liquid level in the corresponding reservoirs (see "Checking brake and clutch fluid level").
- **COOLANT**
Check the level of coolant in the expansion reservoir; top up if necessary (see "Checking and topping up the coolant level").
- **TYRE CONDITION**
Check tyre pressure and condition (see "Tubeless tyres").

- **CONTROLS**
Work the brake, clutch, throttle and gear change controls (levers, pedals and twistgrip) and check for proper operation.
- **LIGHTS AND INDICATORS**
Make sure lights, indicators and horn work properly. Replace any burnt-out bulbs (see "Replacing headlight light bulbs").
- **KEY LOCKS**
Check the tightening of the filler plug (see "Filler plug").
- **STAND**
Make sure side stand operates smoothly and is in the correct position (see "Side stand").

Attention

In case of malfunction, do not ride the motorcycle and contact a Ducati Dealer or authorised Service Centre.

To ensure trouble-free operation, the engine coolant pump requires a breather. This means that it is possible that a very small quantity of coolant oozes out of the breather hole positioned in the upper part of the crankcase, and this will not affect proper operation of the engine or the cooling system.

ABS light

After key-on, the ABS light (9) stays on.
When the motorcycle speed exceeds 5 km/h, the warning light switches OFF to confirm the correct operation of the ABS system.



Attention

In case of malfunction, do not ride the motorcycle and contact a Ducati Dealer or authorised Service Centre.

ABS device

Check that the front (1) and rear (2) phonic wheels are clean.



Attention

Clogged reading slots would compromise system proper operation. It is recommended to disable ABS system in case of muddy road surface because under this condition the system might be subject to sudden failure.



Attention

Prolonged wheelies could deactivate the ABS system.

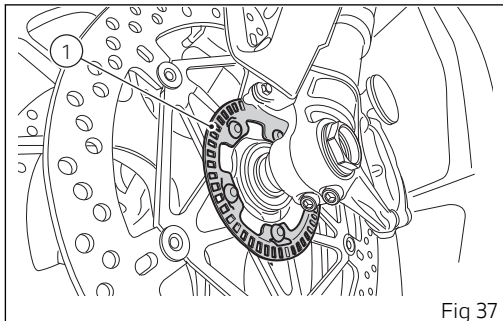

Fig 37

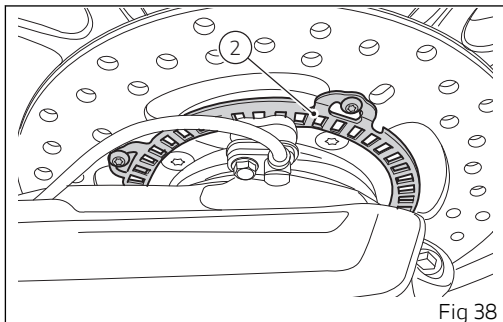

Fig 38

Engine start/stop

Attention

Before starting the engine, become familiar with the controls you will need to use when riding.

Attention

Never start or run the engine indoors. Exhaust gases are poisonous and may lead to loss of consciousness or even death within a short time.

Move the ignition key to ON. Make sure both the green light N (1) and the red light  (2) on the instrument panel come on.

Important

The oil pressure light should go out a few seconds after the engine has started.

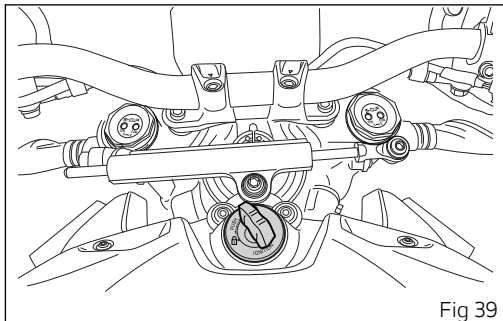

Fig 39

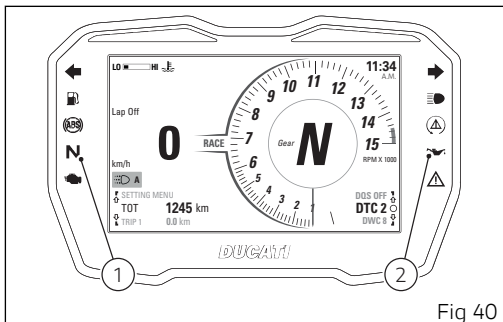

Fig 40

Attention

The side stand must be fully up (in a horizontal position) as its safety sensor prevents engine starting when down.

Note

It is possible to start the engine with side stand down and the gearbox in neutral. When starting the motorcycle with a gear engaged, pull the clutch lever (in this case the side stand must be up).

Important

Do not rev up the engine when it is cold. Allow some time for oil to be heated and reach all points that need lubricating.

Attention

Keeping the engine running for too long with the vehicle stationary can cause damage because of overheating due to insufficient cooling. Do not keep the engine on unnecessarily while the vehicle is stationary. Move off with the motorcycle immediately after starting the engine.

Check that the stop switch (3) is positioned to (RUN), then press the starter button (4).

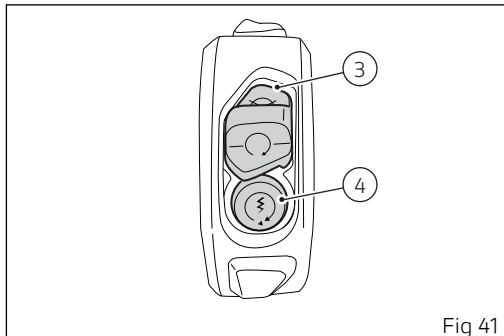

Fig 41

Moving off

- 1) Lift the side stand until it is horizontal.
- 2) Squeeze the control lever to disengage the clutch.
- 3) Push down on gear change lever sharply with the tip of your foot to engage the first gear.
- 4) Speed up the engine by turning the throttle twistgrip while gradually releasing the clutch lever; the motorcycle will start moving off.
- 5) Let go of clutch lever and speed up.
- 6) To shift up, close the throttle to slow down engine, disengage the clutch, lift the gear change lever and let go of clutch lever. To shift down, proceed as follows: release the twistgrip, pull the clutch lever, shortly speed up to help gears synchronise, shift down (engage next lower gear) and release the clutch.

The controls should be used correctly and timely: when riding uphill do not hesitate to shift down as soon as the motorcycle tends to slow down, so you will avoid stressing the engine and the motorcycle abnormally.



Attention

Avoid harsh acceleration, as this may lead to misfiring and transmission snatching. The clutch lever should not be held in longer than necessary after a gear is engaged, otherwise friction parts may overheat and wear out.



Attention

Prolonged wheelies could deactivate the ABS system.



Note

The engine control unit disables the 2 rear bank cylinders when engine is idling and the throttle twistgrip is fully released. This disabling is only implemented when some conditions are verified and namely depending on the engine temperature, gear engaged and clutch lever position (that must be completely pulled unless gear is in Neutral). This strategy ensures advantages in terms of fuel economy and rider's comfort because of less heat.

Anti-Lock Braking System (ABS)

Using the brakes correctly under adverse conditions is the hardest – and yet the most critical – skill to master for a rider. Braking is one of the most difficult and dangerous moments when riding a two wheeled motorcycle: the possibility of falling or having an accident during this difficult moment is statistically higher than any other moment. A locked front wheel leads to loss of traction and stability, resulting in loss of control.

The Anti-Lock Brake System (ABS) has been developed to enable riders to use the motorcycle braking power to the fullest possible amount in emergency braking or under poor pavement or adverse weather conditions.

ABS uses hydraulics and electronics to limit pressure in the brake circuit when a special sensor mounted to the wheel informs the electronic control unit that the wheel is about to lock up.

This avoids wheel lockup and preserves traction.

Pressure is raised back up immediately and the control unit keeps controlling the brake until the risk of a lockup disappears. Normally, the rider will perceive ABS operation as a harder feel or a pulsation of the brake lever and pedal.

The front and rear brakes use separate control systems, meaning that they operate independently. Likewise, the ABS is not an integral braking system and does not control both the front and rear brake at the same time.

If desired, the system can be deactivated from the instrument panel by using the "Customising Riding Modes: "ABS setting" function.

Motorcycle braking and stop

Braking

Slow down in time, shift down to use engine brake and then brake by operating both front and rear brakes.

Stop

Reduce speed, shift down and release the throttle twistgrip. Shift down to engage first gear and then neutral.

Do not release the clutch with a gear engaged to prevent the engine from suddenly stopping.

Apply the brakes and bring the motorcycle to a complete stop.

To switch the engine off, simply turn the key to OFF ("Ignition switch and steering lock").

Parking

Park the stopped motorcycle on the side stand. To prevent theft, turn the handlebar fully left and turn the ignition key to the LOCK position.

If you park in a garage or other indoor area, make sure that there is proper ventilation and that the motorcycle is not near a source of heat.



Important

Never leave the ignition key in the switch when you are leaving your motorcycle unattended.



Attention

The exhaust system might be hot, even after engine is switched OFF; pay particular attention not to touch the exhaust system with any body part and do not park the motorcycle next to inflammable material (wood, leaves etc.).



Attention

Using padlocks or other locks designed to prevent motorcycle motion, such as brake disc locks, rear sprocket locks, and so on is dangerous and may impair motorcycle operation and affect the safety of rider.

Refueling

Never overfill the tank when refuelling. Fuel should never be touching the rim of filler recess.

Warning

The fuel pressure inside the tank may, in extreme cases, cause fuel to "spray" when opening the fuel cap.

Always open the fuel cap slowly and carefully during the refill.

If you hear an audible hiss from the cap while opening it, wait until the stop of the hissing before opening it completely.

The sound is residual pressure escaping from the fuel tank, therefore the stop of the hiss indicates that there is no more residual pressure.

The situation described above is more likely in hot weather conditions.

Attention

Use fuel with low lead content and an original octane number of at least 95.

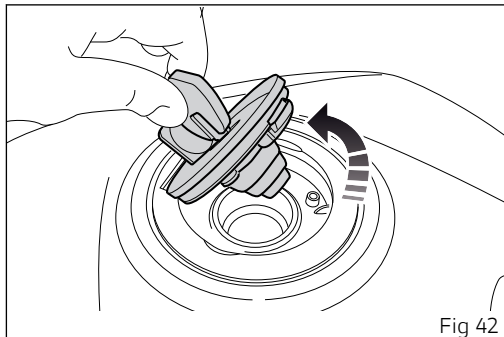

Attention

The motorcycle is only compatible with fuel having a maximum content of ethanol of 10% (E10). Using fuel with ethanol content over 10% is forbidden. Using it could result in severe damage of the engine and motorcycle components. Using fuel with ethanol content over 10% will make the warranty null and void.

Fuel label

The label identifies the fuel recommended for this vehicle.

1) The E5 reference inside the label indicates the use of fuel with a maximum oxygen content of 2.7% by weight and a maximum ethanol content of 5% by volume, according to EN 228.

2) The E10 reference inside the label indicates the use of fuel with a maximum oxygen content of 3.7% by weight and a maximum ethanol content of 10% by volume, according to EN 228.

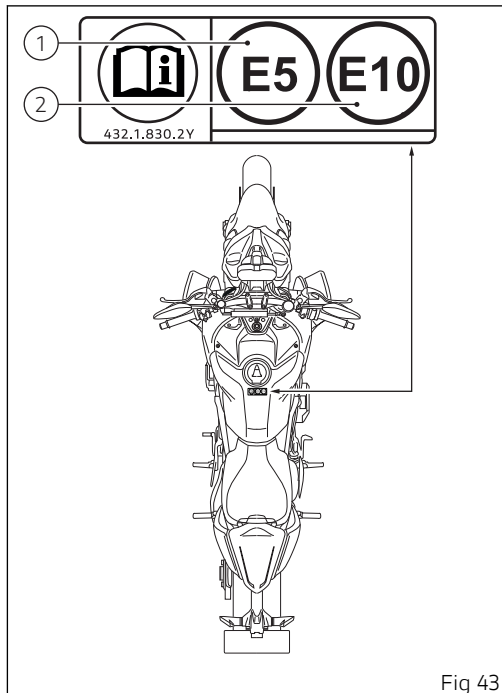

Fig 43

Tool kit and accessories

The glove compartment positioned inside the seat back (A) contains a 4 mm (0.16 in) L-shaped Allen wrench (1).

To gain access to the compartment, remove the passenger seat (A) as described in chapter “Removing and refitting the seats”.

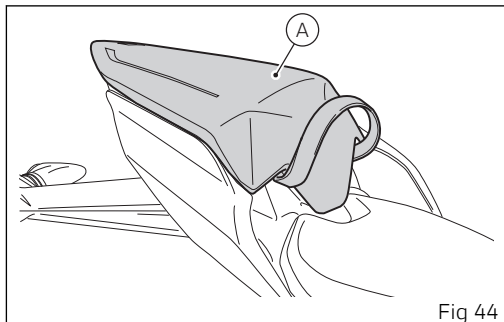

Fig 44

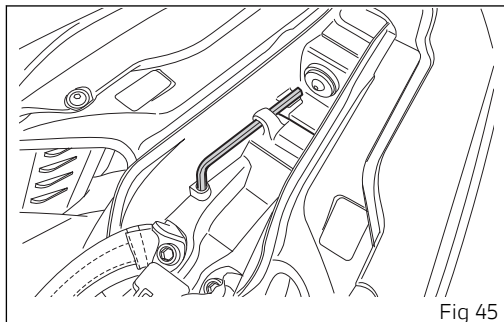

Fig 45

Instrument panel (Dashboard)

Instrument panel

- 1) DISPLAY
- 2) NEUTRAL LIGHT (GREEN)
- 3) GENERIC ERROR WARNING LIGHT (AMBER YELLOW)
- 4) HIGH BEAM LIGHT (BLUE)
- 5) FUEL WARNING LIGHT (AMBER YELLOW)
- 6) TURN INDICATOR LIGHTS (GREEN)
- 7) ENGINE OIL PRESSURE LIGHT (RED)



Important

If the ENGINE OIL light stays ON, stop the engine or it may suffer severe damage.

- 8) DAVC STATUS LIGHT (AMBER YELLOW)
 - Light off: DTC/DWC/DSC enabled and functioning;

- Light ON flashing: DTC/DWC/DSC enabled, but with degraded performance;
- Light steady ON: DTC/DWC/DSC disabled and/or not functioning due to a fault in the control unit.

9) ENGINE DIAGNOSIS - MIL LIGHT (AMBER YELLOW)

- The warning light turns steady on in case of error in engine management. Proceed slowly, avoid harsh acceleration and overtaking, take the vehicle to a Ducati authorised service centre to eliminate the malfunction.
- The warning light turns on flashing to warn about a critical emission-related error that could damage the catalytic converter. If possible, have the vehicle be taken to a Ducati authorised service centre and the malfunction eliminated and at any rate proceed slowly, avoid harsh acceleration and overtaking.

10) ABS LIGHT (AMBER YELLOW)

- Light off: ABS enabled and functioning;
- Light ON flashing: ABS in self-diagnosis and/or functioning with degraded performance;

- Light steady ON: ABS disabled and/or not functioning due to a fault in the ABS control unit.

11) DRL WARNING LIGHT (GREEN) (not present in China, Canada versions)

12) DTC/DWC INTERVENTION (AMBER YELLOW)

- Light OFF: no DTC intervention.
- Light steady ON: DTC intervention.

13) OVER REV / IMMOBILIZER SYSTEM (RED)

Over rev:

- Light OFF: no limiter intervention;
- Light ON: limiter intervention.

Immobilizer:

- Light OFF: key-on status or key-off status for over 24 hours;
- Light ON flashing: key-off status;

Important

If the display shows the message “TRANSPORT MODE”, immediately contact your Ducati Dealer that will delete this message and ensure the full operation of the motorcycle.

Upon key-on, the instrument panel displays the Ducati logo together with the loaded performance

map (none, RACING, RACING EVO, RACING PRO) and carries out a sequential check of the LED warning lights.

After this routine, the instrument panel displays the main page in one of the available modes (TRACK, ROAD), depending on the one in use before last KEY-OFF.

During this first check stage, if the motorcycle speed exceeds 5 km/h (3 mph), the instrument panel will stop:

- the display check routine and display the standard screen containing updated information;
- the warning light check routine and leave ON only the warning lights that are actually active at the moment.

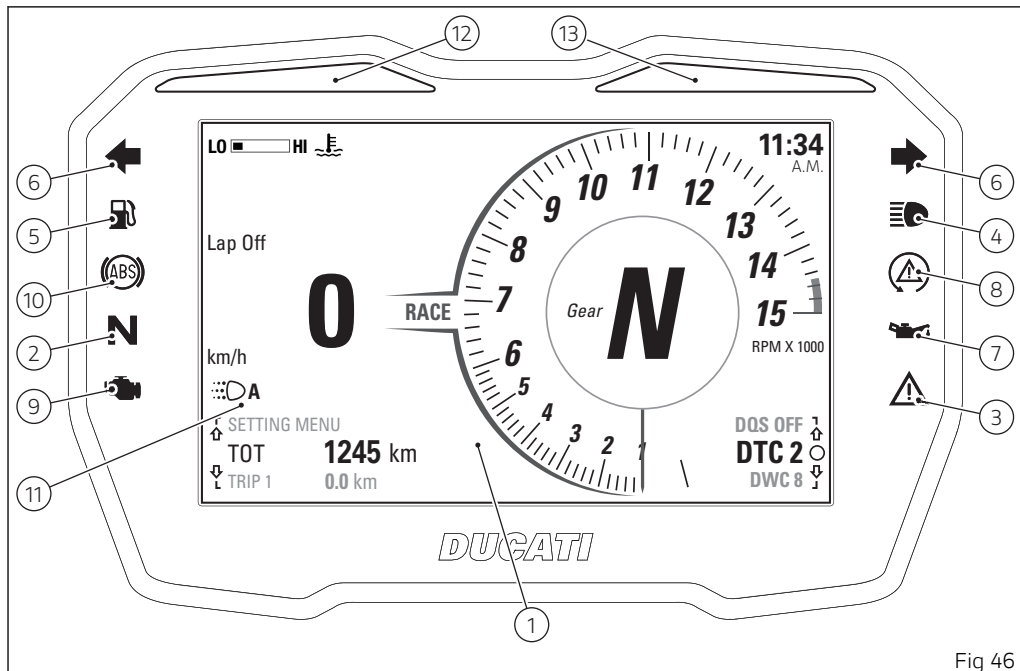

Fig 46

Display mode (Info Mode)

Two display modes (Info Mode) are available in the main screen: TRACK and ROAD.

By using the "Info Mode" in the "SETTING MENU" it is possible to set the display mode for the currently set Riding Mode (see chapter "SETTING MENU - Riding Mode - Info Mode").

It is furthermore possible to set the main screen background colour in the "Day" or "Night" mode by using the "Backlight" function available in the "SETTING MENU" (see chapter "SETTING MENU - Backlight").

Data displayed on the main screen for TRACK layout are as follows:

- 1) Motorcycle speed
- 2) Engine Coolant temperature
- 3) Set Riding Mode
- 4) Gear indication
- 5) Rev counter
- 6) Clock
- 7) LAP time (Lap) - if activated
- 8) Bluetooth indication (if present only)
- 9) Indication of missed calls or received sms / mms / e-mails (only if Bluetooth is available and with a connected smartphone)

- 10) Connected device indication (only if Bluetooth is available and with connected devices)
- 11) Function menu
- 12) Parameter menu and level change
- 13) DRL lights status (DRL lights are not present in the China, Canada versions)
- 14) DDA function status (only if the DDA is connected to the motorcycle)

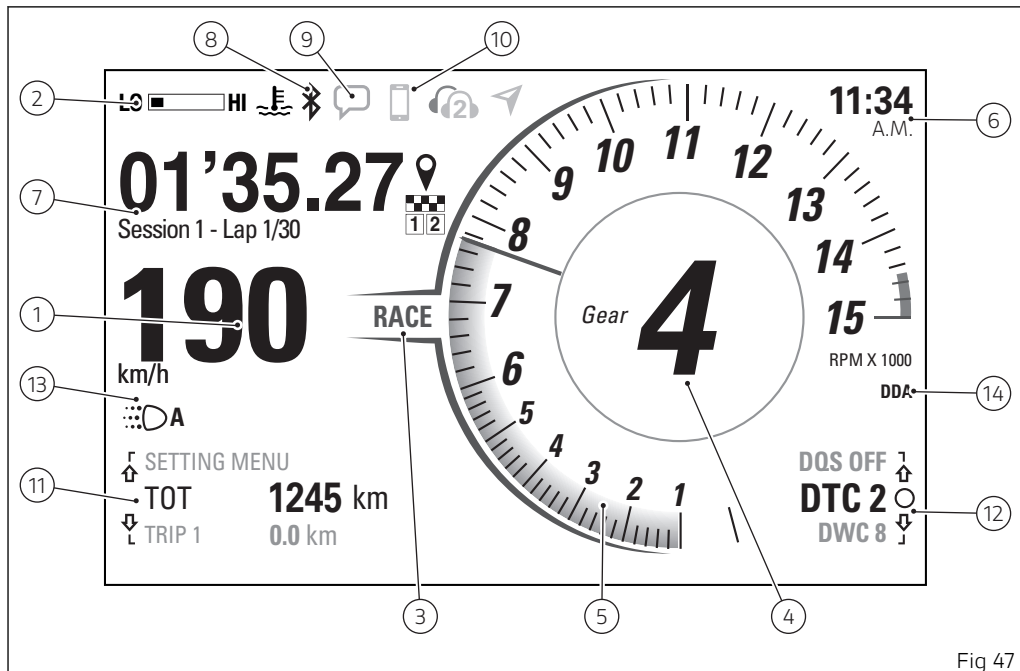

Fig 47

Data displayed on the main screen for ROAD layout are as follows:

- 1) Motorcycle speed
- 2) Engine Coolant temperature
- 3) Set Riding Mode
- 4) Gear indication
- 5) Rev counter
- 6) Clock
- 7) Infotainment — Player (volume / track selection / track control) (only if Bluetooth is present, smartphone connected and Player active)
- 8) Bluetooth indication (if present only)
- 9) Indication of missed calls or received sms / mms / e-mails (only if Bluetooth is available and with a connected smartphone)
- 10) Connected device indication (only if Bluetooth is available and with connected devices)
- 11) Function menu
- 12) Parameter menu and level change
- 13) DRL lights status (DRL lights are not present in the China, Canada versions)
- 14) DDA function status (only if the DDA is connected to the motorcycle)

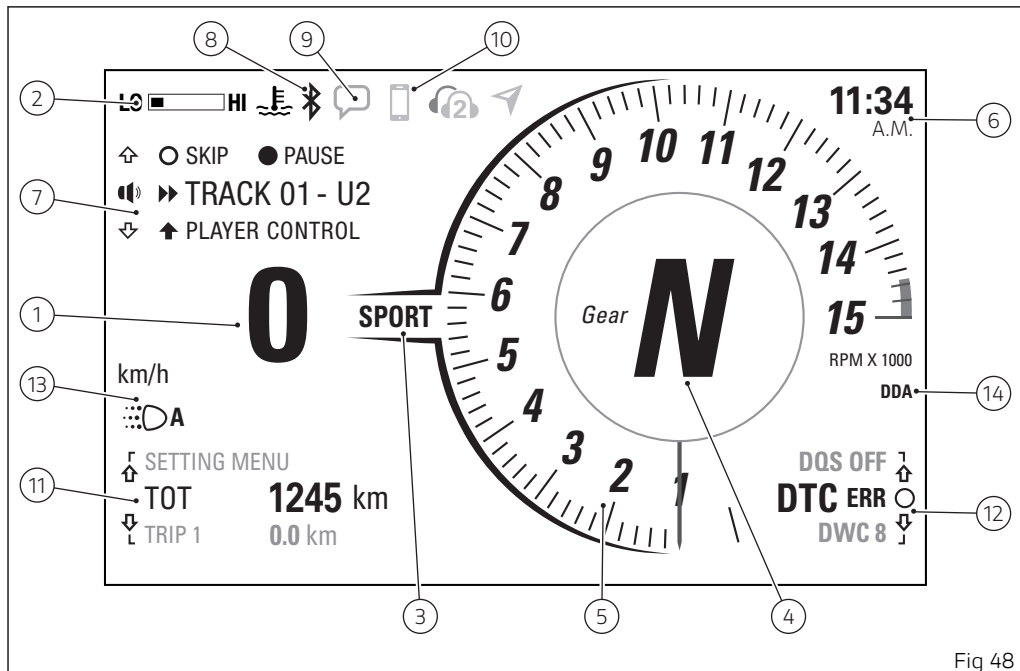

Fig 48

Main and auxiliary functions

The functions displayed in the Standard screen are the following:

Main information

- Motorcycle speed
- Engine rpm indication
- Gear indication
- Set Riding Mode
- Engine Coolant temperature
- Clock
- Parameter and quick level change menu: DTC, DWC, DSC, EBC, ABS, DQS.
- Function menu:
 - TOT - Odometer
 - TRIP 1 - Trip meter 1
 - CONS. AVG 1 - Average consumption
 - SPEED AVG 1 - Average speed
 - TRIP 1 TIME - Trip time
 - T AIR - External air temperature
 - TRIP FUEL - Partial fuel reserve counter
 - TRIP 2 - Trip meter 2
 - CONS. I. - Instantaneous fuel consumption
 - PLAYER (OFF / ON) - Player management, present only if the Bluetooth module

(accessory) is installed and one smartphone is connected (visible only in the ROAD Info Mode)

LAST CALLS - Call management, present only if the Bluetooth module (accessory) is installed and one Smartphone is connected (visible only in the ROAD Info Mode)

LAP (OFF / ON) - Lap time (visible only in the TRACK Info Mode)

SETTING MENU

The functions within the Setting Menu that can be modified by the user are the following:

- Riding Mode
 - DAVC setting (DAVC)
 - DAVC - DTC setting (DTC)
 - DAVC - DWC setting (DWC)
 - DAVC - DSC setting (DSC)
 - DAVC setting - value reset (Default)
 - Engine setting (Engine)
 - ABS setting (ABS)
 - EBC setting (EBC)
 - DQS setting (DQS)
 - Display mode setting (Info Mode)
 - Setting reset for every single riding mode (Default)
 - Value reset (All Default)

- Pin Code activation/modification (Pin Code)
- Lap time (Lap)
- backlighting setting (Backlight)
- date and time setting (Date and Clock)
- unit of measurement setting (Units)
- service information (Service)
- tyre setting and drive ratio (Tyre Calibration)
- DRL light mode setting (DRL)
- Bluetooth device settings - accessory (Bluetooth)
- DDA data management (DDA)
- turn indicator mode setting (Turn indicators)
- information (Info)

Additional information

- Lap time display (Lap basic, Lap Evo)
- Assisted start (Launch Control - DPL)
- Infotainment
- Heated handgrips
- DRL automatic mode indication
- Service indication (SERVICE)
- Warning/Alarm indication
- Side stand status
- Error indication

Vehicle speed indication

Speed indication is displayed increased by 5% and together with the set unit of measurement (km/h or mph).

It is possible to change unit of measurement through the "Units" function in the "SETTING MENU".

A string of three dashes "-" - "-" is displayed with the set unit of measurement if:

- speed is above 299 km/h (186 mph);
- the speed sensor is in fault (flashing "-" - "-").

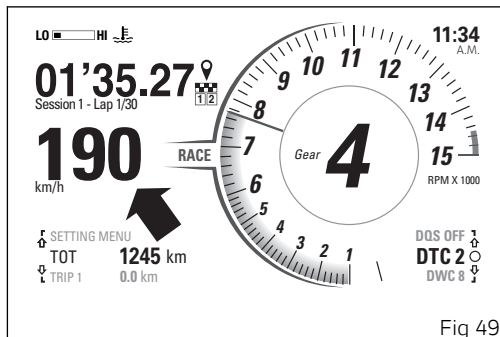

Fig 49

Gear indication

The gear engaged (1– 6) is displayed at the centre of the rev counter.

If gear is in neutral, the letter "N" is displayed and the Neutral warning light turns on.

In case of gear sensor error, a dash "-" will be displayed together with the Neutral warning light flashing.

Note

If the display shows "-" steady on and the Neutral light is off, then the gearbox could be in a mechanically unstable position; in such a case, up/downshift until the correct gear is indicated.

Note

When the rpm indicator becomes amber yellow, the instrument panel is warning the rider to shift up.

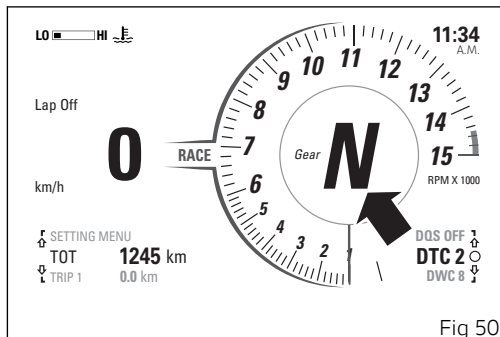

Engine rpm indication

The rev counter scale is displayed in mode (A) in TRACK Info Mode and is displayed in mode (B) in ROAD Info Mode. To set the Info Mode, refer to chapter "SETTING MENU - Riding Mode - Info Mode".

The engine rpm is displayed using a rev counter featuring a coloured wake (C): grey in DAY mode and white in NIGHT mode

When the wake becomes amber yellow, the instrument panel is warning the rider to shift up. The red wake flashes when the limiter kicks in and the 15 Over-rev warning light turns on. If the number of rpm is lower than 1,000 RPM, the wake is not displayed.

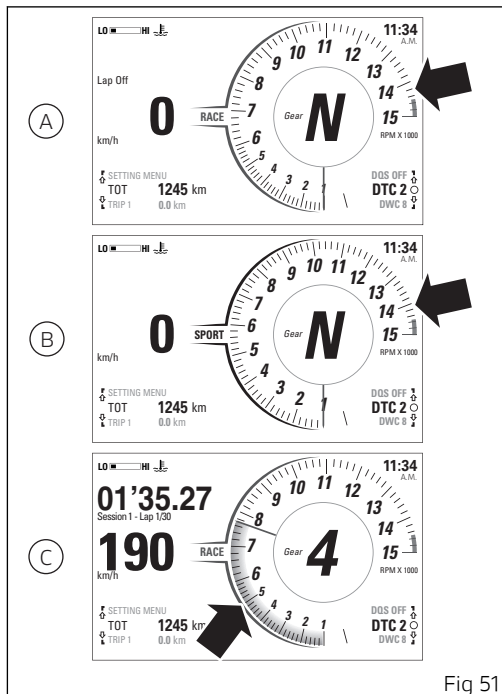

Fig 51

Clock

The instrument panel displays the time in the format HH:MM (hours:minutes), followed by "AM" or "PM" indication.

In case of a power off (Battery Off), upon the following Key-On, the instrument panel displays 4 dashes "-- : --" steadily, with flashing colon and "AM". It is hence necessary to set the time through the SETTING MENU.

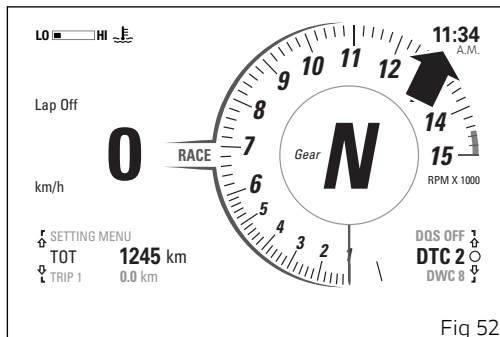

Fig 52

Engine Coolant temperature

The instrument panel displays the engine temperature value through a graduated scale divided into 5 notches between "LO" and "HI" symbols.

The temperature display range goes from +40°C to +215°C (+104°F ÷ +419°F).

When the temperature is within +166° C (+331° F) and +200° C (392° F), the graduated scale is replaced by the red blinking "HIGH" indication.

When the temperature is within +201° C (+394° F) and +215° C (419° F), the white bar is displayed without notches.

Attention

In case of overheating, if possible, it is recommended to ride at reduced speed to allow the cooling system to lower the engine temperature. If this is not possible due to traffic conditions, stop and turn the engine off.

If the motorcycle continues to be used when the engine is overheated, severe damage may occur.

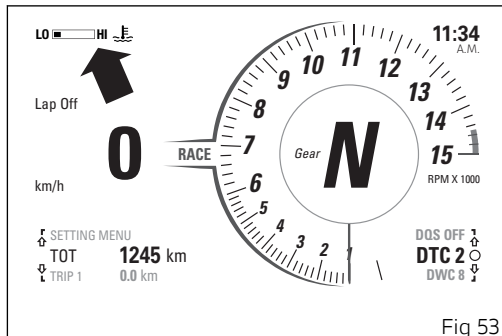

When the engine temperature returns to normal, continue riding by frequently checking the instrument panel indication.

Riding Mode

3 Riding Modes are available: RACE, SPORT, STREET.

The name of the active Riding Mode is displayed in the central part of the display, between the speed value and the rev counter.

Each Riding Mode is associated with a different colour for the name and rev counter box.

- red for RACE
- black in day mode or white in night mode for SPORT
- grey for STREET

The parameters associated to each Riding Mode are: ENGINE, DTC, ABS, DWC, DSC, EBC, DQS.

For each Riding Mode it is possible to customise the parameters using the "Riding Mode" function in the SETTING MENU (see chapter "SETTING MENU - Riding Mode").

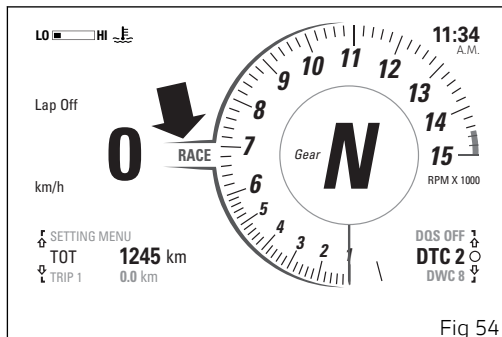

Fig 54

Change Riding Mode as follows:

- Hold ENTER button depressed for 1 second. System opens the page from which it is possible to scroll the available Riding Modes and view their parameters, together with the relevant settings.
- Use the navigation buttons to select the desired Riding Mode.
- Press ENTER button to confirm.

Select "Exit" and press ENTER button to quit the Riding Mode change function without making any changes.

As soon as the new Riding Mode is confirmed, the instrument panel checks the following conditions:

- If speed is lower than or equal to 5 km/h (3 mph) and throttle control is open, the message "Close throttle" is displayed; the new Riding Mode is confirmed and stored only when throttle control is closed and the main screen is displayed.
- If speed is lower than or equal to 5 km/h (3 mph), throttle control is closed but brakes are actuated, the message "Release brakes" is displayed; the new Riding Mode is confirmed

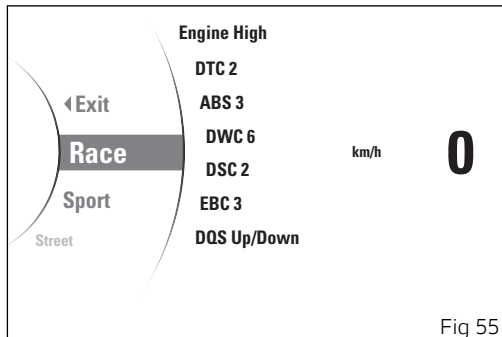

and stored only when brakes are released and the main screen is displayed.

- If both the previously specified conditions are true, message "Close throttle and release brakes" is displayed; the new Riding Mode is confirmed and stored only when the 2 conditions are as required and the main screen is displayed.

If either of the conditions required to validate the change of Riding Mode are not true within 5 seconds from activation of one of the above-described conditions, the procedure will be aborted, the

instrument panel will go back to displaying the main page and no settings will be changed.



Attention

Ducati recommends changing the Riding mode when the motorcycle is stopped. If the riding mode is changed while riding, be very careful (it is recommended to change the Riding mode at a low speed).

Parameter menu and quick level change

In the lower right corner of the main screen the parameter menu that allows a quick level change is displayed.

The following parameters and their currently set values are displayed:

- DTC
- DWC
- DSC
- EBC
- ABS
- DQS

With the quick selection buttons UP (6, Fig 57) and DOWN (7, Fig 57) it is possible to scroll in rotation the list of available parameters.

When the empty circle symbol at the right of the parameter is displayed, it is possible to change level by pressing the quick selection button (5, Fig 57).

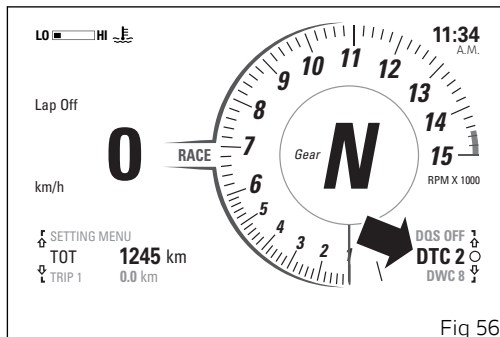

Oil change

Parameters for which it is possible perform the quick change are the following: DTC, DWC, DSC, EBC. In this mode, the display shows the selected parameter and the relevant currently set level.

With navigation buttons (6) and (7) it is possible to scroll through the levels available for the parameter to be modified.

By pressing the SELECT button (5), you confirm the selected level and the instrument panel shows the previous screen.

The set level is memorised for the currently use Riding Mode.

Note

If a parameter has been set to "off" through the SETTING MENU (e.g. DTC, DWC, DSC), "off" status is displayed and it is not possible to perform its quick change.

Note

Through the quick change it is not possible to disable the parameter by setting an "off" level.

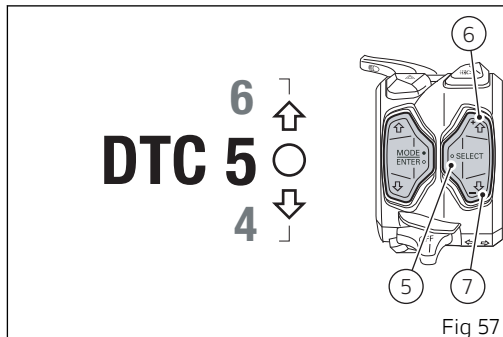

DTC indicator

The instrument panel displays DTC current level.

If DTC is in degraded operation mode, relevant indication is displayed flashing; also the DTC/DWC warning light turns on.

When in fault, the red "Err" message is displayed instead of the current level; also DTC/ DWC warning light turns on.

When DTC is set to "OFF", also the DWC will be automatically set to "OFF" and the DTC/DWC warning light will turn on.

Attention

In case of system malfunction, contact a Ducati Dealer or Authorised Service Centre.

The Ducati Traction Control system (DTC) supervises the rear wheel slipping control and settings vary through eight different levels that are calibrated to offer a different tolerance level to rear wheel slipping. Each Riding Mode features a pre-set intervention level. Level 8 indicates system intervention whenever a slight slipping is detected, while level 1 is for track use and very expert riders because it is less sensitive to slipping and intervention is hence softer.

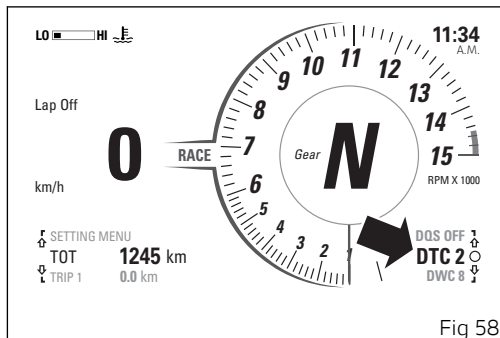

Attention

DTC is a rider aid that can be used both on the road and on the track. The system is designed to make riding easier and to enhance safety, but in no way relieves the rider of the obligation to drive responsibly and to maintain a high standard of riding in order to avoid accidents, whether caused by his own errors or those of other road users, through making emergency manoeuvres, in accordance with the prescriptions of the road traffic code.

The rider must always be aware that active safety systems have a preventive function. The active

elements help the rider control the motorcycle, making it as easy and safe to ride as possible. The presence of an active safety system should not encourage the rider to ride at speeds beyond the reasonable limits, not in accordance with the road conditions, the laws of physics, good riding standards and the requirements of the road traffic code

The following table indicates the most suitable level of DTC intervention for the various riding modes, as well as the default settings in the "Riding Mode" that can be selected by the rider:

DTC LEVEL	RIDING MODE	OPERATION CHARACTERISTIC	DEFAULT
OFF		The DTC is disabled.	NO
1	TRACK Professional	This level is designed for exclusive track use, for very expert riders. In this mode, the DTC allows side slipping.	NO
2	TRACK	This level is designed for exclusive track use and for very expert riders. It is optimised for OEM tyres. In this mode, the DTC allows side slipping.	NO
3	SPORT / TRACK	This level is designed for track use and for expert riders. In this mode, the DTC allows side slipping.	It is the default level for the "RACE" Riding Mode
4	SPORT / TRACK	This level is designed for track use (and road use, for expert riders).	NO
5	SPORT	This level is designed for riding both on the road and on the track.	It is the default level for the "SPORT" Riding Mode

DTC LEVEL	RIDING MODE	OPERATION CHARACTERISTIC	DEFAULT
6	SAFE & STABLE	This level is designed for use in any riding conditions, on the road with good grip. Compatible with ENGINE MED setting.	It is the default level for the "STREET" Riding Mode
7	RAIN	This level is designed for track use, exclusively with Rain tyres when surface is wet.	NO
8	HEAVY RAIN	This level is designed for road use, when surface is wet and very slippery. ENGINE LOW must be used for an optimum operation of this level.	NO

Tips on how to select the sensitivity level



Attention

Excellent operation of the DTC system, for all available levels, is ensured only with OE tyres and/or with the ones recommended by Ducati and with the OE final drive ratio. In particular, OE tyres for this motorcycle are Pirelli Diablo Rosso Corsa II in the following sizes: 120/70ZR17 at the front, 200/60ZR17 at the rear. The use of tyres of different size and characteristics to the original tyres may alter the operating characteristics of the system thus making it unsafe. It is recommended not to install tyres of different size than the ones approved for your vehicle.

As far as tyres are concerned, in the case of minor differences such as, for example, tyres of a different make and/or model than the OE ones, it is necessary to use the relevant automatic calibration function in order to restore correct system operation.

As far as the final ratio is concerned, when using a different ratio (which is only possible for tracing use) than the original equipment one, it is recommended to use the relevant automatic calibration function in order to restore optimal system operation.

The choice of the correct level depends on 3 main variables:

- 1) The grip (type of tyre, amount of tyre wear, the road/track surface, weather conditions, etc.)
- 2) The characteristics of the path/circuit (bends all taken at similar speeds or at very different speeds)
- 3) The riding mode (whether the rider has a "smooth" or a "rough" style)

Level depends on grip conditions

The choice of level setting depends greatly on the grip conditions of the track/path (see below, tips for use on the track and on the road). Poor grip requires a higher level that ensures a more aggressive DTC intervention.

Level depends on type of track

If the track/path features bends all taken at similar speeds, it will be easier to find a level suitable for all bends; while a track/path with bends all requiring different speeds will require a DTC level setting that is the best compromise for all bends.

Level depends on riding style

The DTC will tend to kick in more with a "smooth" riding style, where the motorcycle is leaned over further, rather than with a "rough" style" where the motorcycle is straightened up as quickly as possible when exiting a turn.

Tips for use on the track

We recommend that level 6 is used for a couple of full laps in order to heat the tyres and get used to the system. Then try levels 6, 5, 4, etc., in succession until you identify the DTC sensitivity level that suits you best.

Once you have found a satisfactory setting for all the corners except one or two slow ones, where the system tends to kick in and control too much, you can try to modify your riding style slightly to a more "rough" approach to cornering i.e. straighten up more rapidly on exiting the corner, instead of immediately trying a different level setting.

Tips for use on the road

We recommend the level in order to get used to the system. If the level of DTC intervention seems

aggressive, try reducing the setting to levels 5, 4, etc., until you find the level that suits you best.

If changes occur in the grip conditions and/or circuit characteristics and/or your riding style, and the level setting is no longer suitable, switch to the next level up or down and proceed to determine the best setting (e.g. if with level 5 the DTC intervention seems excessive, switch to level 4; alternatively, if on level 5 you cannot perceive any DTC intervention, switch to level 6).

DWC indicator

The instrument panel displays DWC current level.

If DWC is in degraded operation mode, relevant indication is displayed flashing; also the DTC/DWC warning light turns on.

When in fault, the red "Err" message is displayed instead of the level; also DTC/ DWC warning light turns on.

Note

If DTC is set to "OFF", also the DWC will be automatically set to "OFF".

Attention

In case of system malfunction, contact a Ducati Dealer or Authorised Service Centre.

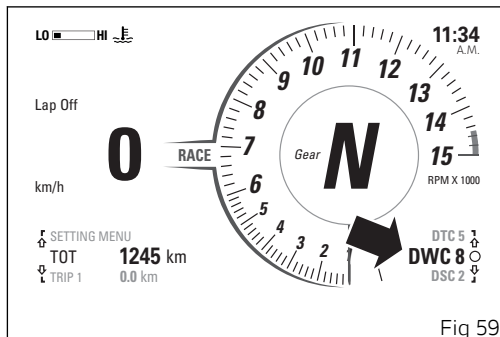

Attention

DWC is a rider aid that can be used on both the track and the road. The system is designed to make riding easier and to enhance safety, but in no way relieves the rider of the obligation to drive responsibly and to maintain a high standard of riding in order to avoid accidents, whether caused by his own errors or those of other road users, through making emergency manoeuvres, in accordance with the prescriptions of the road traffic code.

The rider must always be aware that active safety systems have a preventive function. The active

elements help the rider control the motorcycle, making it as easy and safe to ride as possible. The presence of an active safety system should not encourage the rider to ride at speeds beyond the reasonable limits, not in accordance with the road conditions, the laws of physics, good riding standards and the requirements of the road traffic code.

The following table indicates the most suitable level of DWC intervention for the various riding types as well as the default settings in the "Riding Mode" that can be selected by the rider.

DWC LEVEL	USE		DEFAULT
OFF		The DWC is disabled.	NO
1	HIGH PERFORMANCE	Track use for very expert riders. The system allows wheelies, but decreases the speed at which the front wheel lifts.	NO
2	MEDIUM PERFORMANCE	Track use for expert riders. The system allows wheelies, but decreases the speed at which the front wheel lifts.	NO
3	PERFORMANCE	Track use for expert riders. The system allows wheelies, but decreases the speed at which the front wheel lifts.	It is the default level for the "RACE" Riding Mode
4	PERFORMANCE	Track use for all kinds of riders. The system allows wheelies, but decreases the speed at which the front wheel lifts.	It is the default level for the "SPORT" Riding Mode
5	SPORT	Level for all kinds of riders. The system reduces the motorcycle's proneness to do wheelies and sensitively intervenes in case of wheelie.	NO

DWC LEVEL	USE		DEFAULT
6	SPORT	Level for all kinds of riders. The system reduces the motorcycle's proneness to do wheelies and sensitively intervenes in case of wheelie.	It is the default level for the "STREET" Riding Mode
7	MEDIUM SAFE & STABLE	Level for all kinds of riders. The system reduces the motorcycle's proneness to do wheelies and sensitively intervenes in case of wheelie.	NO
8	HIGH SAFE & STABLE	Level for all kinds of riders. The system reduces the motorcycle's proneness to do wheelies to a minimum level and sensitively intervenes in case of wheelie.	NO

Tips on how to select the sensitivity level



Attention

Excellent operation of the DWC system, for all available levels, is ensured only with the OE final drive ratio and with OE tyres and/or with the ones recommended by Ducati. In particular, OE tyres for this motorcycle are Pirelli Diablo Rosso Corsa II in the following sizes: 120/70ZR17 at the front, 200/60ZR17 at the rear. The use of tyres of different size and characteristics to the original tyres may alter the operating characteristics of the system thus making it unsafe. It is recommended not to install tyres of different size than the ones approved for your vehicle.

As far as tyres are concerned, in the case of minor differences, such as for example, tyres of a different make and/or model than the OE ones, but with the same size (rear = 200/60 ZR17; front = 120/70 ZR17), it is necessary to use the relevant automatic calibration function in order to restore correct system operation.

As far as the final ratio is concerned, when using a different ratio (which is only possible for tracing use) than the original equipment one, it is recommended

to use the relevant automatic calibration function in order to restore optimal system operation.

At level 8 the DWC system reduces the motorcycle's proneness to do wheelies to a minimum level and sensitively intervenes in case of wheelie. Between level 8 and level 1 there are further intermediate levels of intervention for the DWC. Levels 1, 2 and 3 allow easier wheelies, but reduce their speed: these levels are recommended only for track use and for expert riders who can control wheelies on their own and exploit the system feature that reduces the speed at which the front wheel tends to lift.

The choice of the correct level mainly depends on the following parameters:

- The rider's experience;
- The characteristics of the path/circuit (bend exit with low or high gear engaged).

The rider's experience

The choice of level setting depends greatly on the riders' experience and ability to control wheelies on their own. Levels 1, 2 and 3 require a great experience to ensure proper control.

Level depends on type of track

If the track/path features bends where out speed and gear are low, a lower level will be necessary; while a track/path with faster bends will allow the use of a higher level setting.

Tips for use on the track

We recommend to use level 8 for a couple of full laps in order to get used to the system. Then try levels 7, 6, etc., in succession until you identify the DWC sensitivity level that suits you best (always try each level for at least two laps to allow the tyres to warm up).

Tips for use on the road

Activate the DWC, select level 8 and ride the motorcycle in your usual style; if the level of DWC sensitivity seems excessive, try levels 7, 6, etc., until you find the one that suits you best. If changes occur in the circuit characteristics, and the level setting is no longer suitable, switch to the next level up or down and proceed to determine the best setting (e.g. if with level 7 the DWC intervention seems excessive, switch to level 6; alternatively, if on level 7

you cannot perceive any DWC intervention, switch to level 8).

DSC indication

The instrument panel displays DSC current level.

If DSC is in degraded operation mode, relevant indication is displayed flashing; also the DAVC warning light turns on.

When in fault, the red "Err" message is displayed instead of the current level; also the DAVC warning light turns on.

When the DTC is set to "OFF", the DAVC warning light turns on.

Attention

In case of system malfunction, contact a Ducati Dealer or Authorised Service Centre.

Note

If DTC is set to OFF, DSC is also forced to OFF.

The Ducati Slide Control (DSC) system assists the rider during the acceleration when exiting a curve in order to better control the side slipping of the rear wheel. The system thus improves the intervention of the single DTC function that works on the tyre longitudinal slipping providing better assistance in extreme riding conditions.

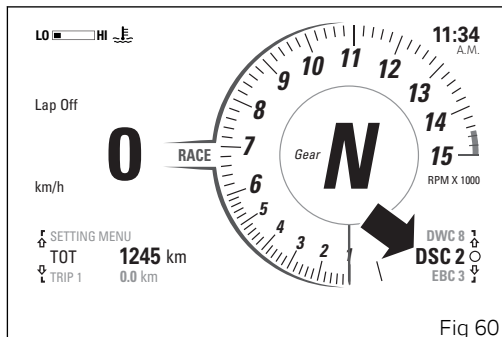

Fig 60

The DSC system works on 2 different levels, each calibrated to offer a different intervention on the side slipping of the tyre in combination with a specific DTC level.

The following table indicates the most suitable DSC intervention level depending on the riding modes. Depending on the selected DTC level, the different levels are optimized for tyres and the indicated DTC levels.

DSC level	Use	Default
OFF	The DSC is disabled.	NO
1	The basic intervention level depends on the selected DTC level. The DSC system increases the intervention extent in a limited way in order limit side slipping.	NO
2	The basic intervention level depends on the selected DTC level. The DSC system increases the intervention extent in a more significant way in order limit side slipping.	It is the default level for the "RACE", "SPORT" and "STREET" Riding Modes.



Attention

The DSC system assists the rider in the control of the rear tyre side slipping and facilitates the acceleration out of curves. Therefore, the system does not prevent the rider from reaching potentially dangerous leaning angles and for safety reasons it must be used with due riding care.

Tips on how to select the intervention level

According to the riding style, the curve-exit phase can be performed in a rougher or smoother way and can lead to different leaning angles. Therefore, it is suitable to follow the indications provided below to identify the intervention level most appropriate for your riding style.

To this end, we recommend to identify first the most suitable DTC level according to the indications provided in the DTC system description. Then, we recommend selecting the DSC 2 level, i.e. the most invasive intervention, and ride some laps to become familiar with the system. If the system intervention on the lateral grip is too strong, we recommend trying DSC 1 level, associated to a softer intervention.

If non-OEM tyres of a different size class are used or if the tyre size differs significantly from the original tyres, it may be that the system operation is compromised.

As far as tyres are concerned, in the case of minor differences such as, for example, tyres of a different make and/or model than the OE ones, it is necessary to use the relevant automatic calibration function in order to restore correct system operation.



Attention

The DSC is a rider assist system. The system is designed to make riding easier and to enhance safety, but in no way relieves the rider of the obligation to drive responsibly and to maintain a high standard of riding in order to avoid accidents, whether caused by his own errors or those of other road users, through making emergency manoeuvres, in accordance with the prescriptions of the road traffic code.

The rider must always be aware that active safety systems have a preventive function. The active elements help the rider control the motorcycle, making it as easy and safe to ride as possible. The presence of an active safety system should not encourage the rider to ride at speeds beyond the reasonable limits, not in accordance with the road conditions, the laws of physics, good riding standards and the requirements of the road traffic code.

EBC indication

The instrument panel displays EBC current level.

If EBC is in degraded operation mode, relevant indication is displayed flashing.

When in fault, the red "Err" message is displayed instead of the level.

The engine brake control system (EBC) works together with the slipper clutch to avoid and control the rear wheel lock-up during aggressive downshifting.

EBC features a three-tiered operating system and is integrated in the three Riding Modes.

The Engine Braking Control (EBC) system controls engine braking when riding with throttle control completely closed (both when downshifting and in a normal cut-off with the same gear engaged, while braking or not). This system independently adjusts the throttle valves to ensure a consistent torque goes back from the wheel to engine during these stages.

The system allows the rider to set "engine brake", the range being from a maximum engine braking with system set to level 1, and progressively decreasing as level increases.

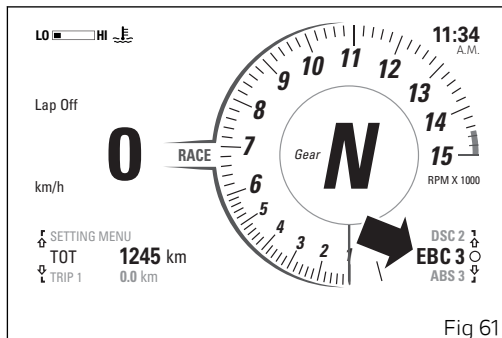

Fig 61

System is particularly sensitive at high rpm and sensitivity gradually decreases as soon as engine rpm decrease.



Attention

EBC is a rider aid that can be used both on the track and the road. The system is designed to make riding easier, but in no way relieves the rider of the obligation to ride responsibly and to maintain a high standard of riding in order to avoid accidents, whether caused by his own errors or those of other road users, through making emergency manoeuvres, in accordance with the prescriptions of the road traffic code.

Table of EBC interventions within the Riding Mode:

The following table indicates the most suitable level of EBC intervention for the various riding modes as well as the default settings in the "Riding Modes" that can be selected by the rider.

EBC	CHARACTERISTIC	DEFAULT
1	In this level the engine delivers the maximum engine brake.	It is the default level for the RACE, SPORT and STREET Riding Modes.
2	In this level the engine delivers a low engine brake. This level is recommended to any rider requiring reduced engine braking in deceleration.	NO
3	In this level the engine delivers the least engine brake. This level is recommended to any rider requiring very low engine braking in deceleration.	NO

Tips on how to select the sensitivity level



Attention

Excellent operation of the EBC system, for all available levels, is ensured only with OE tyres and/or with the ones recommended by Ducati and with the OE final drive ratio. In particular, OE tyres for this motorcycle are Pirelli Diablo Rosso Corsa II in the following sizes: 120/70ZR17 at the front, 180/60ZR17 at the rear. The use of tyres of different size and characteristics to the original tyres may alter the operating characteristics of the system thus making it unsafe. It is recommended not to install tyres of different size than the ones approved for your vehicle.

As far as tyres are concerned, in the case of minor differences such as, for example, tyres of a different make and/or model than the OE ones, it is necessary to use the relevant automatic calibration function in order to restore correct system operation.

As far as the final ratio is concerned, when using a different ratio (which is only possible for tracing use) than the original equipment one, it is recommended to use the relevant automatic calibration function in order to restore optimal system operation.

Selecting level 3, the EBC will kick in to ensure the minimum engine brake possible. Between level 3 and level 1 the engine brake levels are increasing progressively; with level 1 you set the maximum engine brake level possible.

The choice of the correct level mainly depends on the following parameters:

- 1) The grip (type of tyre, amount of tyre wear, the road/track surface, weather conditions, etc.).
- 2) The characteristics of the path/circuit (bends all taken at similar speeds or at very different speeds).
- 3) The Riding Mode.

Level depends on grip conditions

The choice of level setting depends greatly on the grip conditions of the track/circuit.

Level depends on type of track

If the track/path requires consistent braking (always aggressive or always smooth), it will be easier to find a level suitable for all braking instances; while a track/path requiring different braking power will require an EBC system level setting that is the best compromise for all instances.

ABS indicator

The instrument panel displays ABS current level.

If ABS is in degraded operation mode, current level is displayed flashing; also the ABS warning light flashes.

When in fault, the red "Err" message is displayed instead of the level; also ABS warning light turns on. When the ABS is in self-diagnosis stage, the ABS warning light flashes.

Attention

In case of system malfunction, contact a Ducati Dealer or Authorised Service Centre.

Using the brakes correctly under adverse conditions is the hardest – and yet the most critical – skill to master for a rider. Braking is one of the most difficult and dangerous moments when riding a two wheeled motorcycle: the possibility of falling or having an accident during this difficult moment is statistically higher than any other moment.

A locked front wheel leads to loss of traction and stability, resulting in loss of control.

The Anti-Lock Braking System (ABS) has been developed to enable riders to use the motorcycle braking force to the fullest possible amount in

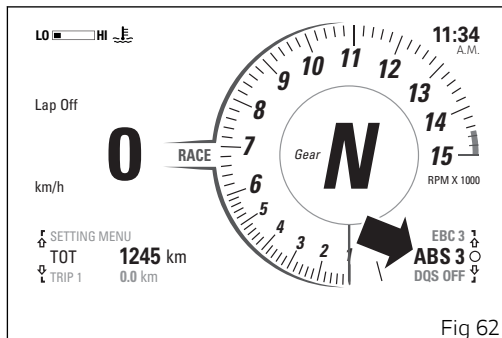

Fig 62

emergency braking or under poor pavement or adverse weather conditions.

ABS is an electro-hydraulic device that controls the pressure in the brake circuit when the control unit, by processing information from wheel sensors, determines that one or both wheels are about to lock up. In this case, pressure decrease in the brake circuit allows the wheel to carry on turning, thereby preserving grip.

After that, the control unit restores the pressure in the brake circuit, to resume the braking action.

This cycle is repeated many times until the problem is completely eliminated.

Normally, the rider will perceive ABS operation as a harder feel or a pulsation of the brake lever and pedal. The front and rear brakes use separate control systems.

The ABS system fitted to the Streetfighter V4 is a safety system preventing wheel lockup while braking, adopting different strategies depending on the selected level.

The active presence of strategies and their intervention level depend on the selected level. The ABS offers 3 intervention levels.

The Streetfighter V4 ABS features a "cornering" function that optimises ABS functionality to the conditions where the motorcycle is leaning over, thus preventing wheel lockup and slipping as much as possible, within the physical limits allowed by the vehicle and by the road conditions. The cornering feature is only active in ABS levels 2 and 3.

According to the selected level, the Streetfighter V4 ABS can implement the anti lift-up function for the rear wheel so as to guarantee not only a reduced

stopping distance under braking, but also the highest possible stability.

In ABS level 1, associated by default to no Riding Mode, the system only works on the front discs to ensure top performance for track use.

In this mode, the cornering function is not active.

In ABS level 2, associated by default to SPORT RACE Riding Mode, also the DSC control (slide control under braking) is active. Under some activation conditions, ensuring in any case the maximum rider safety, the ABS system allows more pronounced slipping at the rear allowing vehicle yaw or slide, so as to permit a more sporty and faster corner entry. This control activates when the user acts on the rear brake during a sufficiently strong braking also at the front.

During the operation of this system, the ABS monitors vehicle slipping or slide level, so that it remains below a safety level, which depends on the lean angle. If vehicle slipping or slide level increases too much, the ABS operates again in standard mode, realigning the vehicle in order to always ensure the maximum safety.



Attention

Using the two brake controls separately reduces the motorcycle braking power. Never use the brake controls harshly or suddenly as you may cause rear wheel lift-up and lose control of the motorcycle. When riding in the rain or on slippery surfaces, braking will become less effective. Always use the brakes very gently and carefully when riding under these conditions. Any sudden manoeuvres may lead to loss of control. When tackling long, high-gradient downhill road tracts, shift down gears to use engine braking. Apply one brake at a time and use brakes sparingly. Keeping the brakes applied all the time would cause the friction material to overheat and reduce braking power dangerously. Underinflated and overinflated tyres reduce braking efficiency, handling accuracy and stability in a bend.

The following table indicates the most suitable level of ABS intervention for the various riding types as well as the default settings in the "Riding Mode" that can be selected by the rider:

LEVEL	RIDING MODE	USE	DEFAULT
1	TRAK PERFORMANCE	This level is designed exclusively for track use, for expert riders (not recommended for road use). ABS in this level only controls the front wheel, and thus allows rear wheel lockup. The system in this level does NOT control lift-up nor it activates the cornering function.	No Riding Mode is associated to this level by default.
2	ROAD PERFORMANCE	This level is designed for use when riding on the road and on the track, with good grip conditions. ABS in this level controls both wheels and the cornering function is active. In this level system does NOT control lift-up: this calibration focuses on braking power and wheel lift-up should be managed by the rider. In this level, also the DSC (slide control under braking) is active.	It is the default level for the "RACE" Riding Mode.

LEVEL	RIDING MODE	USE	DEFAULT
3	ROAD SAFE/STABLE	This level is designed for use in any riding conditions to provide a safe and consistent braking action. ABS in this level controls both wheels and the cornering and anti-lift-up functions are active.	It is the default level for the "SPORT" and "STREET" Riding Modes.

Tips on how to select the intervention level

Attention

Excellent operation of the ABS system, for all available levels, is ensured only with the OE brake system and with OE tyres and/or with the ones recommended by Ducati. In particular, OE tyres for this motorcycle are:

- Pirelli Diablo Rosso Corsa 2 120/70ZR17 at the front
- Pirelli Diablo Rosso Corsa 2 200/60ZR17 at the rear

The use of tyres of different size and characteristics to the original tyres may alter the operating characteristics of the system thus making it unsafe. It is recommended not to install tyres of different size than the ones approved for your vehicle.

Selecting level 3, the ABS will ensure a very stable braking thanks to lift-up control, and the motorcycle will keep a good alignment during the whole braking action.

ABS level 3 features active cornering function which, with vehicle leaning over, prevents wheel lockup and slipping as much as possible, within the physical

limits allowed by the vehicle and by the road conditions.

Selecting level 2, the ABS will privilege more and more the braking power rather than stability and lift-up control, which is disabled in level 2.

ABS level 2 features active cornering function which, with vehicle leaning over, prevents wheel lockup and slipping as much as possible, within the physical limits allowed by the vehicle and by the road conditions. Moreover, level 2 activates the DSC function (available in this level only).

ABS level 1 is specific for track use and ABS is active only on the front wheel to help performance. In this level there is no lift-up control nor the cornering function.

The choice of the correct level mainly depends on the following parameters:

- 1) The tyre/road grip (type of tyre, amount of tyre wear, the road/track surface, weather conditions, etc.).
- 2) The rider's experience and sensitivity: expert riders can tackle a lift-up in trying to reduce the stopping distance to a minimum, while less expert riders are recommended to use setting 3,

that will help them keeping the motorcycle more stable even in emergency braking.

DQS indicator

The instrument panel displays DQS status as follows:

- if DQS is enabled, "DQS U-D" indication (both upshifting and downshifting);
- if DQS is disabled, "DQS Off " indication;
- if the DQS system or the control unit is in fault, the "Err" indication;
- if DQS is in reduced performance mode, "DQS" indication is displayed flashing.

The DQS with up/down feature allows the rider to upshift and downshift without using the clutch lever. It includes a two-way microswitch - built in the lever mechanism - that outputs a signal to the engine control unit whenever the gearchange is operated. The system works in a separate way for upshifting and downshifting, and combines the action on ignition advance and injection, available in the upshift system, with controlled throttle opening for operation during downshifting.

Here below are some tips that will ensure you properly exploit this feature:

- The Ducati Quick Shift takes the same shift lever operation as with vehicle not equipped with the

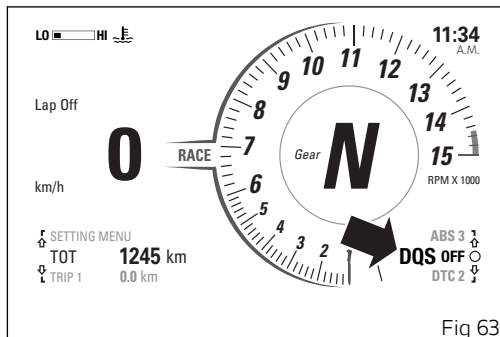

Fig 63

Ducati Quick Shift. Ducati Quick Shift is not designed for shifting automatically.

- For any gearshift request (upshifting or downshifting) the rider has to move the shift lever from its idle position in the desired direction against the force of the spring through a certain over-travel, then keep the shift lever in this position until the gearshift is completed. Once the gearshift has been completed, the lever has to be fully released in order to allow another gearshift acted by Ducati Quick Shift. If the rider does not move the shift lever up to end

stroke during a Ducati Quick Shift request, gears may not be fully engaged.

- Ducati Quick Shift provides no assistance for the gearshift if the rider uses the clutch lever.
- Ducati Quick Shift electronic shifting will not activate when the clutch lever is pulled.
- Ducati Quick Shift will shift down (downshifting) only when the throttle control is completely closed.
- If the Ducati Quick Shift strategy does not work properly, it is always possible to complete the gear shifting using the clutch lever.
- If the gear lever is held pressed up or down for more than 30 seconds (even if just by accident) a plausibility error can be memorised in the electronic control unit and the Ducati Quick Shift system could be disabled; in this case, to reactivate the system, it is necessary to release the lever, switch the instrument panel off, wait for 5 minutes and switch the instrument panel on again.
- Ducati Quick Shift is designed to operate above 2,500 rpm.
- No matter the gear engaged, downshifting with Ducati Quick Shift (downshifting) only works below a set threshold, so as to avoid exceeding

the maximum rpm allowed when the lower gear is engaged.

Function menu



From the main screen, use the navigation buttons to scroll through menu functions.

Based on the set Info Mode and Riding Mode, the Menu can display different functions.

All functions available in the Function Menu are:

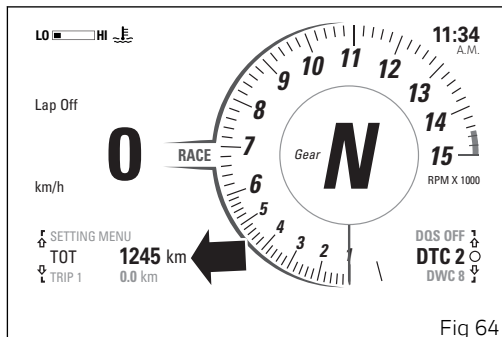
- TOT - Odometer
- TRIP 1 - Trip meter 1
- CONS. AVG 1 - Average consumption
- SPEED AVG 1 - Average speed
- TRIP 1 TIME - Trip time
- T AIR - External air temperature
- TRIP FUEL - Partial fuel reserve counter
- TRIP 2 - Trip meter 2
- CONS. I. - Instantaneous fuel consumption
- PLAYER (OFF / ON) - Player management, present only if the Bluetooth module (accessory) is installed and one smartphone is connected (visible only in the ROAD Info Mode)
- LAST CALLS - Call management, present only if the Bluetooth module (accessory) is installed and one Smartphone is connected (visible only in the ROAD Info Mode)
- LAP (OFF / ON) - Lap time (visible only in the TRACK Info Mode)
- SETTING MENU



The UP  and DOWN  arrows - corresponding to the navigation buttons - appear on the LH side of the menu indicating the possibility to scroll through the functions. The empty circle symbol  is displayed when it is possible to interact with the displayed function by pressing ENTER button, for instance to reset TRIP 1.

TOT

The odometer displays the total distance covered by the motorcycle with the set unit of measurement (km or mi).

It is possible to change unit of measurement through the "Units" function in the "SETTING MENU".

The odometer value is saved permanently and cannot be reset under any circumstances.

Note

If a string of flashing dashes "-----" is displayed within odometer function, please contact a Ducati Dealer or Authorised Service Centre.

Note

When the instrument panel is switched on, this function is displayed for 10 seconds and then instrument panel goes back to the function that was set before switch-off.

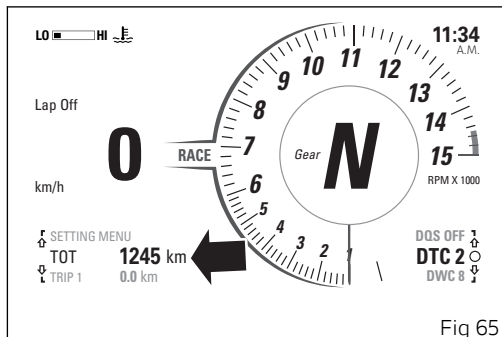

Fig 65

TRIP 1

The TRIP 1 function displays partial distance covered by the vehicle with the set unit of measurement (km or mi).

It is possible to change unit of measurement through the "Units" function in the "SETTING MENU".

When the value exceeds the maximum value of 9999.9, it is automatically reset and the meter starts counting from 0.0 again.

Reset the function as follows:

- view "TRIP 1" indication via the navigation buttons;
- press ENTER button;
- "RESET?" is displayed in place of the meter;
- press UP or DOWN button to cancel, or press ENTER button to confirm.

Reset is automatic also in the following cases:

- reset of CONS. AVG 1;
- reset of SPEED AVG 1;
- reset of TRIP 1 TIME;
- due to a battery disconnection (Battery-Off);
- in case of manual change of the units of measurement of the system using the SETTING MENU.

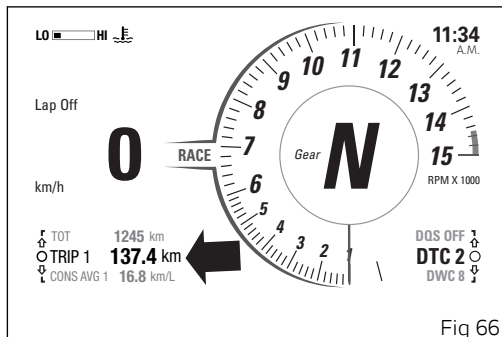

Note

When TRIP 1 is reset, the instrument panel also resets CONS. AVG 1, SPEED AVG 1 and TRIP 1 TIME.

CONS. AVG 1

The CONS. AVG 1 function displays motorcycle average fuel consumption, calculated from last reset.

Value is expressed in the set unit of measurement (km/L, l/100 km, mpg UK, mpg US).

It is possible to change unit of measurement through the "Units" function in the "SETTING MENU".

Reset the function as follows:

- view CONS. AVG 1 indication via the navigation buttons;
- press ENTER button;
- "RESET?" is displayed in place of the meter;
- press UP or DOWN button to cancel, or press ENTER button to confirm.

Reset is automatic also in the following cases:

- reset of TRIP 1;
- reset of SPEED AVG 1;
- reset of TRIP 1 TIME;
- due to a battery disconnection (Battery-Off);
- in case of manual change of the units of measurement of the system using the SETTING MENU.

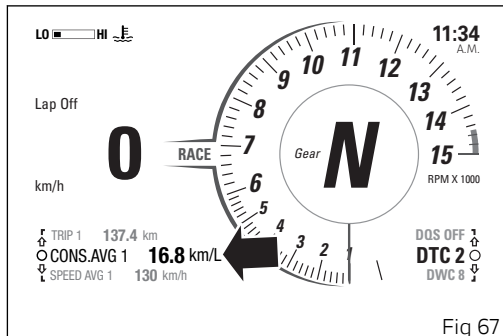

Note

When CONS. AVG 1 is reset, the instrument panel also resets TRIP 1, SPEED AVG 1 and TRIP 1 TIME.



Note

Average fuel consumption is also calculated when motorcycle is at a standstill with engine running.

SPEED AVG 1

The SPEED AVG 1 function displays motorcycle average speed together with the set unit of measurement (km/h or mph), calculated from last reset.

It is possible to change unit of measurement through the "Units" function in the "SETTING MENU".

Reset the function as follows:

- view "SPEED AVG 1" indication via the navigation buttons;
- press ENTER button;
- "RESET?" is displayed in place of the meter;
- press UP or DOWN button to cancel, or press ENTER button to confirm.

Reset is automatic in the following cases:

- reset of TRIP 1;
- reset of CONS. AVG 1;
- reset of TRIP 1 TIME;
- due to a battery disconnection (Battery-Off);
- in case of manual change of the units of measurement of the system using the SETTING MENU.

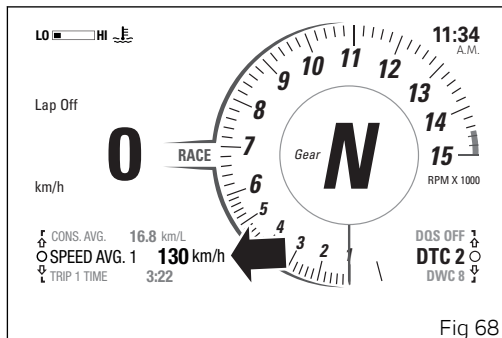

Fig 68



Note

When SPEED. AVG 1 is reset, the instrument panel also resets TRIP 1, CONS AVG 1 and TRIP 1 TIME.



Note

When user resets average speed, a string of three dashes " - - - " is displayed for the first 10 seconds.

TRIP 1 TIME

The TRIP 1 TIME function displays trip time in “hours:minutes”, calculated from the last reset. The value is automatically reset when it exceeds the maximum value of 511:00.

Reset the function as follows:

- view TRIP 1 TIME indication via the navigation buttons;
- press ENTER button;
- “RESET?” is displayed in place of the meter;
- press UP or DOWN button to cancel, or press ENTER button to confirm.

TRIP 1 TIME information is automatically reset also in the following cases:

- reset of TRIP 1;
- reset of CONS. AVG 1;
- reset of SPEED AVG 1;
- due to a battery disconnection (Battery-Off);
- in case of manual change of the units of measurement of the system using the SETTING MENU.

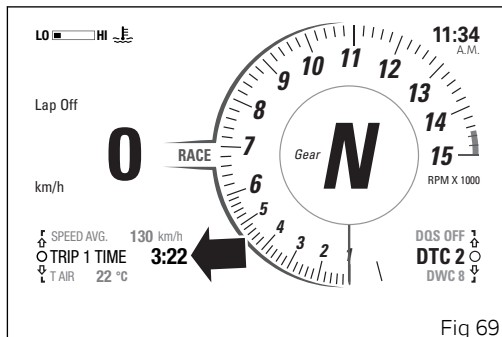

Fig 69



Note

When TRIP 1 TIME is reset, the instrument panel also resets TRIP 1, CONS. AVG 1 and SPEED AVG 1.



Note

Trip time is also calculated when motorcycle is at a standstill with engine running.

T AIR

The T AIR function displays the ambient temperature in °C or in °F.

It is possible to change unit of measurement through the "Units" function in the "SETTING MENU".

The temperature value is displayed when ranging from -39 °C to +125 °C (or -38 °F to +257 °F). For temperature values lower than -39 °C (-38 °F) or higher than +125 °C (+255 °F) a string of three dashes "---" is displayed.

Note

When the motorcycle is stopped, the engine heat could influence the displayed temperature.

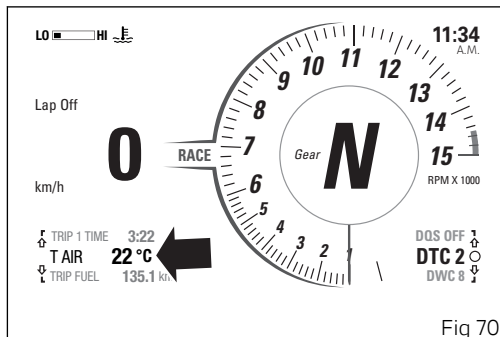

TRIP FUEL

The TRIP FUEL function is only available when the bike starts using the fuel reserve and displays the distance run from the moment the low fuel warning light turns on, together with the set unit of measurement (km or mi).

It is possible to change unit of measurement through the “Units” function in the “SETTING MENU”.

The function is disabled when the bike is no longer in a low fuel condition.

The value referred to the distance run on fuel reserve can be reset in the following cases:

- if value exceeds full scale value (9999.9);
- if user changes unit of measurement through the SETTING MENU;
- after battery disconnection.

Note

The TRIP FUEL function is displayed automatically at the precise moment when the bike starts using the fuel reserve, regardless of the function currently displayed.

At any rate, it is possible to scroll through all the other functions using the navigation buttons.

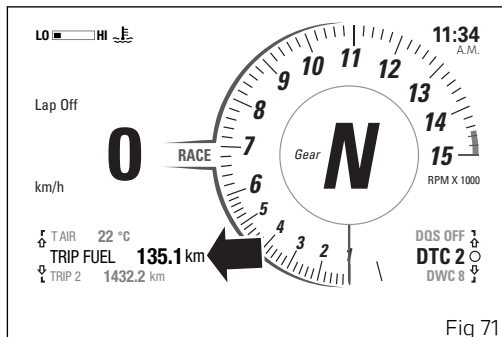

Note

The TRIP FUEL function is not displayed automatically when the SETTING MENU is open or during override through the Pin Code.



Note

If the low fuel condition no longer applies while TRIP FUEL function is displayed, the instrument panel displays again the TOT function.

TRIP 2

The TRIP 2 function displays partial distance covered by the vehicle with the set unit of measurement (km or mi).

It is possible to change unit of measurement through the "Units" function in the "SETTING MENU".

When the reading exceeds the maximum value of 9999.9, distance is automatically reset and the meter starts counting from 0.0 again.

Reset the function as follows:

- view "TRIP 2" indication via the navigation buttons;
- press ENTER button;
- "RESET?" is displayed in place of the meter;
- press UP or DOWN button to cancel, or press ENTER button to confirm.

Reset is automatic also in the following cases:

- due to a battery disconnection (Battery-Off);
- in case of manual change of the units of measurement of the system using the SETTING MENU.

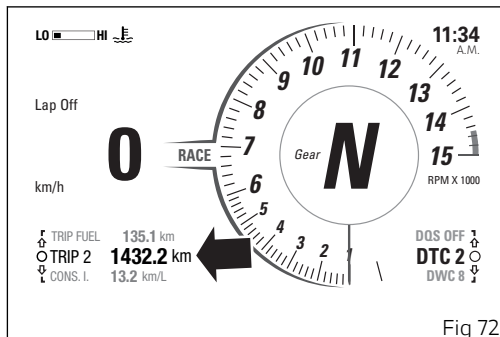

Fig 72

CONS. I.

The CONS. function displays motorcycle instant fuel consumption.

Value is expressed in the set unit of measurement (km/L, l/100 km, mpg UK, mpg US).

It is possible to change unit of measurement through the "Units" function in the "SETTING MENU".

Note

Instant fuel consumption is only calculated when the motorcycle is running and moving.

During the stages when the calculation is not made, a string of three dashes is displayed "- - -" in place of the value.

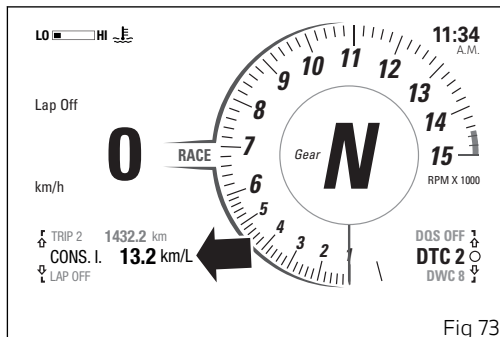

Fig 73

LAP (OFF / ON)

This function is displayed only in the TRACK display mode and allows activating, deactivating and managing the lap time (see chapter "Lap time (LAP)"):

- If LAP is not active, the display shows "LAP OFF". Press the ENTER button to switch it on.
- If LAP is active, the display shows "LAP ON". Press the ENTER button to switch it off.

It is also possible to activate and deactivate the LAP function and manage the recorded lap time with the "Lap" function in the "SETTING MENU" (see chapter "SETTING MENU - Lap").

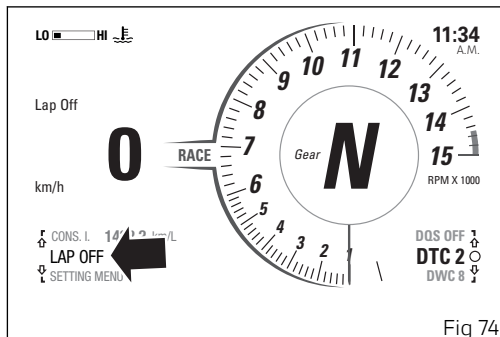

PLAYER (OFF / ON)

This function is displayed only in the ROAD display mode and allows activating, deactivating and managing the music player.

It is available only if the Bluetooth control unit is installed and a smartphone is connected.

The function can be set to "OFF" or "ON".

Important

If the smartphone connected to the instrument panel via Bluetooth is disconnected or switched off, this function will not be listed. It appears again only when the smartphone is connected again to the instrument panel via Bluetooth.

Note

If the rider helmet/intercom is connected in addition to the smartphone, the tracks will be listened through the helmet headphones.

Note

If the LAP function is active, music player activation (PLAYER ON) will stop the LAP functions and set it to OFF.

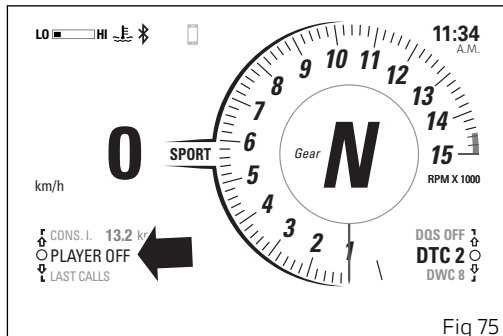

Note

If music player is active (PLAYER ON) and is playing a song from the smartphone, LAP function activation will stop the player and set it to PLAYER OFF.

Music player control enabling

If the music player control is set to “OFF” (Fig 75), press ENTER button to activate it.

With the music player control active, the display shows the title of the track currently being played on the connected smartphone (A), together with the available controls (B), and the “EXIT” indication preceded by the black arrow facing downwards (C).

Note

The full name of the track is displayed once, scrolling the characters from right to left, then only the first characters are displayed. If the title of the track is not available, “NOT AVAILABLE” will be displayed.

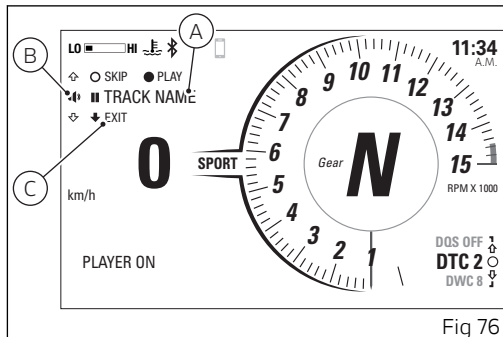

Fig 76

Music player controls

When the control is active, UP button, DOWN button and ENTER button are used by the instrument panel only for the music player controls.

In particular:

- Play/Pause, keep ENTER button pressed for 2 seconds;
- Go to next track "SKIP", press ENTER button;
- Increase volume "+", press UP button;
- Decrease volume "-", press DOWN button;
- Quit the music player control, hold DOWN button depressed for 2 seconds.

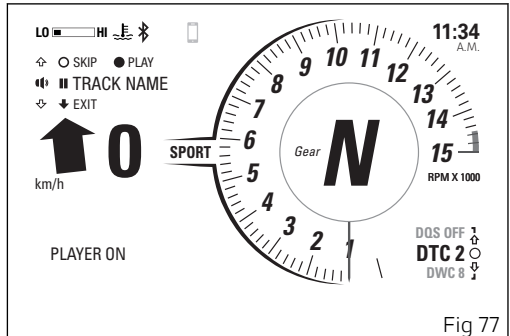

Fig 77

Quit the active music player control (ON)

To exit the music player control (Fig 77) and keep it active, for example with the track being played, press DOWN button for 2 seconds.

Then UP, DOWN and ENTER buttons go back to their "standard" functions for the management/control of the instrument panel and are no longer used for the music player functions.

After its activation, the function is shown within the menu as "PLAYER ON" and a black arrow up is displayed underneath the track title, followed by "PLAYER CONTROL".

Note

With the player on, even if you change function (e.g. TRIP 1), track title remains displayed.

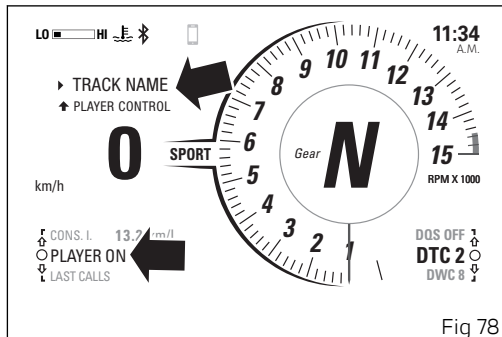

Reactivating the music player control (ON)

To resume music player controls, view PLAYER ON function and press UP button for 2 seconds.

UP, DOWN and ENTER buttons will be again used by the instrument panel only for the music player controls (Fig 77).

Music player control disabling

To disable music player and also stop current track playing, select PLAYER ON function (Fig 78) and press ENTER button.

The function is then shown as "PLAYER OFF" (Fig 75).

LAST CALLS

This function shows the list of the last missed, outgoing or incoming calls and is available only if the Bluetooth control unit is installed and a smartphone is connected.

To display the list of calls, press ENTER button. When entering this function, the display shows message "WAIT.." for a few seconds, then shows the name or phone number from the last call.

Only the last 7 made, received or missed calls are displayed.

Use the navigation buttons to scroll through the listed calls. To make a call to the number/name selected from the list, press ENTER button. For more information refer to the chapter "Infotainment".

If the list of calls is empty, "EMPTY" will be displayed: in this case it is only possible to quit the function.

To exit the function and go back to the previous screen, hold DOWN button depressed for 2 seconds.

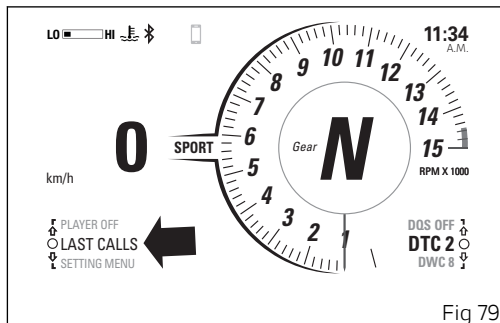

Fig 79

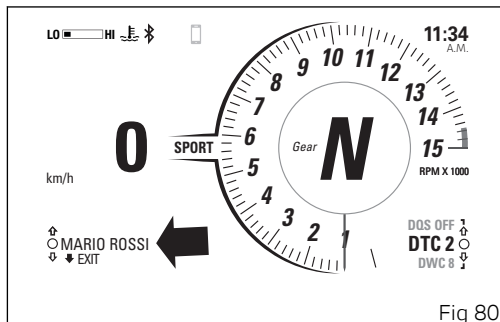

Fig 80

SETTING MENU

This menu allows enabling, disabling and setting some motorcycle functions.

For safety reasons, you can enter this Menu only when the actual vehicle speed is lower than or equal to 5 km/h (3 mph).

If you are inside the SETTING MENU and the speed exceeds 5 km/h (3 mph) the instrument panel automatically displays the main screen.

To enter, use the navigation buttons to select "SETTING MENU" option and press ENTER button.

Important

For safety reasons, it is recommended to use this menu with the motorcycle at a standstill.

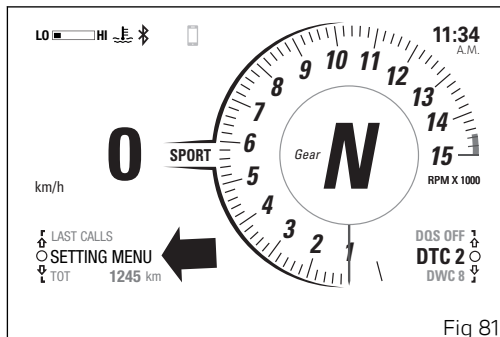

Fig 81

Once entered in the SETTING MENU the display changes the display mode.

The options available inside the menu are:

- Riding Mode
- Pin Code
- Lap
- Backlight
- Date and Clock
- Units
- Service
- Tire Calibration
- DRL – present only if the DRL lights are installed
- Bluetooth – present only if the Bluetooth module is installed (see page 182)
- DDA – present only if DDA is connected
- Turn Indicators
- Info

Use the navigation buttons to scroll through the available items.

After displaying the required function, press ENTER button to view the corresponding sub-menu.

Select "Back" option and press ENTER button to quit any sub-menu.

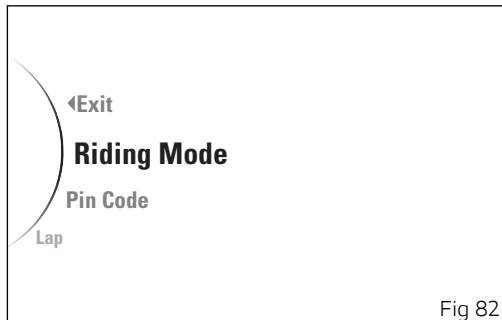

Select "Exit" and press ENTER button to quit the SETTING MENU.

SETTING MENU - Riding Mode

All settings of every riding mode can be customised.

- Enter the SETTING MENU.
- Use the navigation buttons to select "Riding Mode" option and press ENTER button.
- The following options will be displayed in this menu: "Race", "Sport", "Street", "All Default" (visible only if one or more parameters of one or more Riding Modes are different from the default ones).
- Select the required option and press ENTER button.

The parameters that can be customised for every riding mode are the following: Engine, DTC, ABS, DWC, EBC and DQS.

All set values are stored and remain in the memory also after key off.

Attention

Changes should only be made to the parameters by people who are experts in motorcycle set-up. If the parameters are changed accidentally, use the "Default" function to restore factory settings.

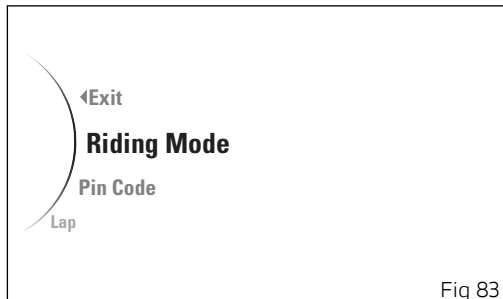

Fig 83

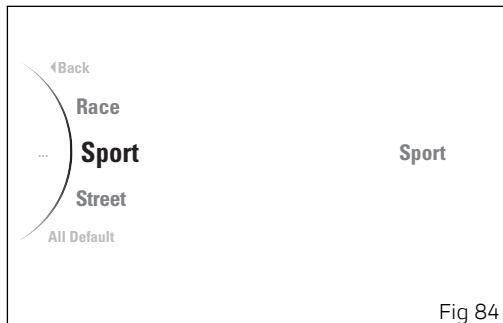

Fig 84

Scheduled maintenance chart: operations to be performed by the Dealer

This function allows setting the levels of functions DTC DWC DSC grouped in the DAVC function associated to each riding mode.

- Enter the SETTING MENU.
- Use the navigation buttons to select "Riding Mode" option and press ENTER button.
- Select the required Riding Mode and press ENTER button.
- Select the "DAVC" option and press ENTER button.

This menu includes the options "DSC", "DWC", "DSC" and "Default" (visible only if one or more parameters are not the default ones).

Select the required option and press ENTER button.

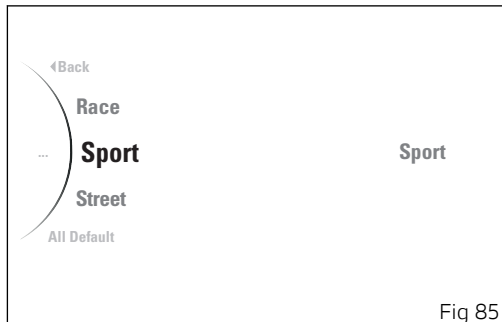

Fig 85

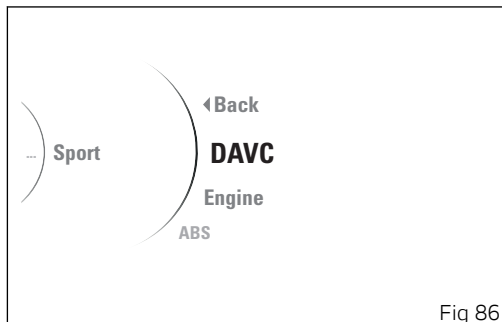

Fig 86

SETTING MENU - Riding Mode - DAVC - DTC

This function disables or sets DTC level for the selected riding mode.

- Enter the SETTING MENU.
- Use the navigation buttons to select "Riding Mode" option and press ENTER button.
- Select the required Riding Mode and press ENTER button.
- Select the "DAVC" option and press ENTER button.
- Select the "DTC" option and press ENTER button.

When entering the function, the display shows available customised settings (level "1" to "8" and "Off") on the left side and current setting on the right side.

The bike profile is also displayed with the trigger zone highlighted, and a chart containing reference information.

Use the navigation buttons to select the required level and press ENTER button to confirm.

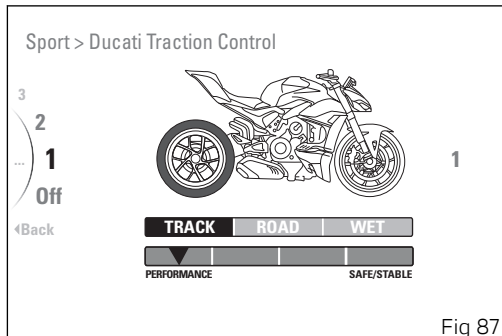

Note

When DTC is set to "Off", also the DWC will be set to "Off".

SETTING MENU - Riding Mode - DAVC - DWC

This function disables or sets DWC level for the selected riding mode.

- Enter the SETTING MENU.
- Use the navigation buttons to select "Riding Mode" option and press ENTER button.
- Select the required Riding Mode and press ENTER button.
- Select the "DAVC" option and press ENTER button.
- Select the "DWC" option and press ENTER button.

When entering the function, the display shows available customised settings (level 1 to 8 and Off) on the left side and current setting on the right side. The bike profile is also displayed with the trigger zone highlighted, and a chart containing reference information.

Use the navigation buttons to select the required level and press ENTER button to confirm.

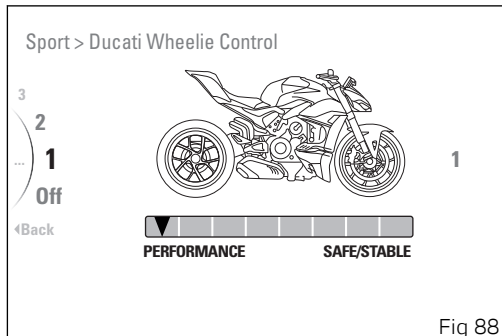

Fig 88



Attention

When DTC is set to "Off", also the DWC will be forced "Off". In this case, the DWC setting is not available.

SETTING MENU - Riding Mode - DAVC - DSC

This function disables DSC level for the selected riding mode.

- Enter the SETTING MENU.
- Use the navigation buttons to select "Riding Mode" option and press ENTER button.
- Select the required Riding Mode and press ENTER button.
- Select the "DAVC" option and press ENTER button.
- Select the "DSC" option and press the ENTER button.

When entering the function, the display shows available customised settings (level "1", "2" and "Off") on the left side and current setting on the right side. The bike profile is also displayed with the trigger zone highlighted, and a chart containing reference information.

Use the navigation buttons to select the required level and press ENTER button to confirm.

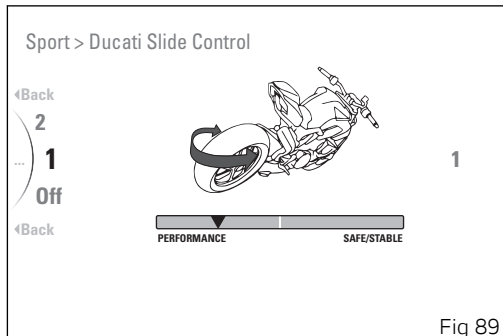

Note

When DTC is set to "Off", also the DSC will be forced "Off". In this case, the DSC setting is not available.

SETTING MENU - Riding Mode - DAVC - Default

This function allows setting the levels of DTC, DWC and DSC set by default by Ducati, grouped in the DAVC function associated to each riding mode.

- Enter the SETTING MENU.
- Use the navigation buttons to select "Riding Mode" option and press ENTER button.
- Select the required Riding Mode and press ENTER button.
- Select the "DAVC" option and press ENTER button.

Select "Default" and press ENTER to reset the default parameters of the DTC, DWC and DSC functions related to the selected Riding Mode are restored.

The "Default" indication remains visible even after restoring the pre-set parameters.

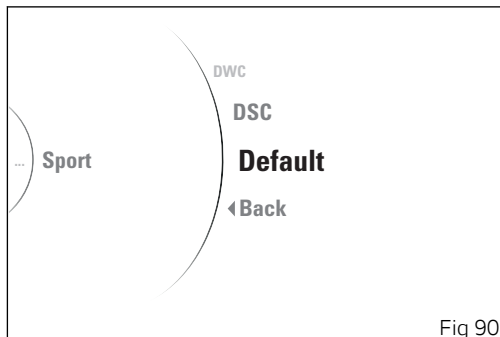

Fig 90

SETTING MENU - Riding Mode - Engine

This function customises engine power associated with each riding mode.

- Enter the SETTING MENU.
- Use the navigation buttons to select "Riding Mode" option and press ENTER button.
- Select the required Riding Mode and press ENTER button.
- Select the "Engine" option and press ENTER button.

When entering the function, the display shows available customised settings - "High", "Medium", "Low" - on the left side and current setting on the right side.

The bike profile is also displayed with the trigger zone highlighted, and a chart containing reference information.

Use the navigation buttons to select the required level and press ENTER button to confirm.

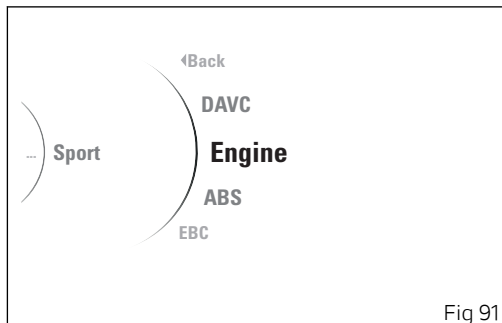

Fig 91

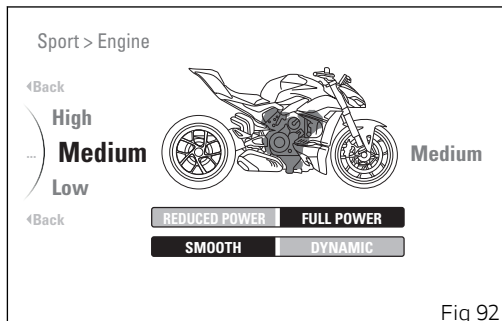

Fig 92

SETTING MENU - Riding Mode - ABS

This function sets ABS level for the selected riding mode.

- Enter the SETTING MENU.
- Use the navigation buttons to select "Riding Mode" option and press ENTER button.
- Select the required Riding Mode and press ENTER button.
- Select the "ABS" option and press ENTER button.

When entering the function, the display shows available customised settings (level "1" to "3") on the left side and current settings on the right side. The bike profile is also displayed with the trigger zone highlighted, and a chart containing reference information.

Use the navigation buttons to select the required level and press ENTER button to confirm.

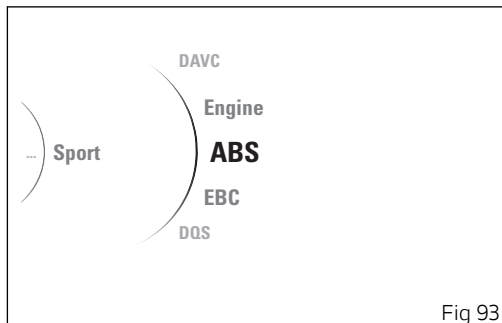

Fig 93

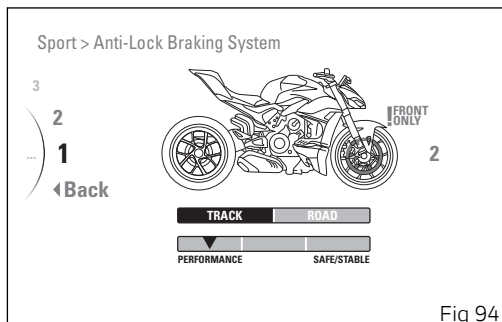

Fig 94

SETTING MENU - Riding Mode - EBC

This function sets EBC level for the selected riding mode.

- Enter the SETTING MENU.
- Use the navigation buttons to select "Riding Mode" option and press ENTER button.
- Select the required Riding Mode and press ENTER button.
- Select the "EBC" option and press ENTER button.

When entering the function, the display shows available customised settings (level "1" to "3") on the left side and current setting on the right side. The bike profile is also displayed with the trigger zone highlighted, and a chart containing reference information.

Use the navigation buttons to select the required level and press ENTER button to confirm.

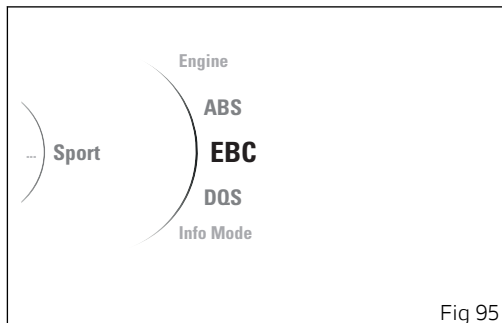

Fig 95

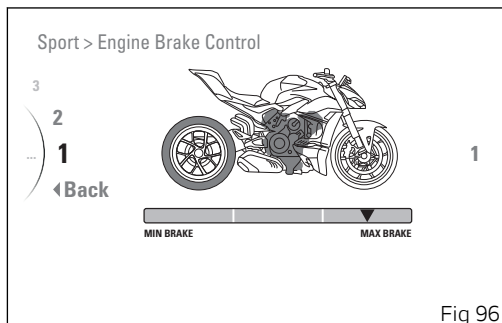

Fig 96

SETTING MENU - Riding Mode - DQS

This function disables or sets DQS level for the selected riding mode.

- Enter the SETTING MENU.
- Use the navigation buttons to select "Riding Mode" option and press ENTER button.
- Select the required Riding Mode and press ENTER button.
- Select the "DQS" option and press ENTER button.

When entering the function, the display shows available customised settings ("Up/Down" and "Off") on the left side and current setting on the right side. The bike profile is also displayed, with the trigger zone highlighted.

Use the navigation buttons to select the required level and press ENTER button to confirm.

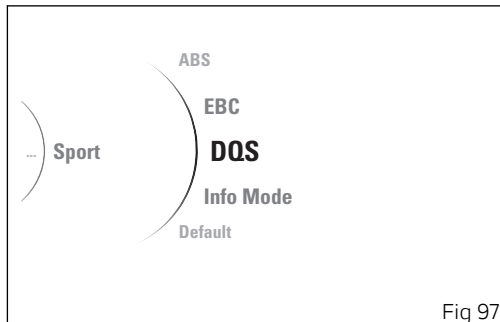

Fig 97

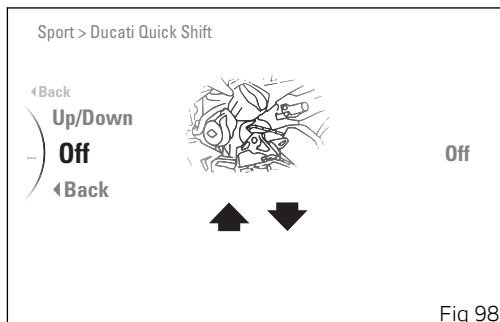

Fig 98

SETTING MENU - Riding Mode - Info Mode

This function allows rider to select the main screen displaying mode associated with every riding mode.

- Enter the SETTING MENU.
- Use the navigation buttons to select "Riding Mode" option and press ENTER button.
- Select the required Riding Mode and press ENTER button.
- Select the "Info Mode" option and press the ENTER button.

When entering the function, the display shows available customised settings ("Track" and "Road") and on the right side the currently set mode.

If the currently set mode is not the default one, among the available options there will be also "Default" which allows setting the Ducati factory mode for the selected Riding Mode.

Use the navigation buttons to select the desired item and press ENTER to confirm.

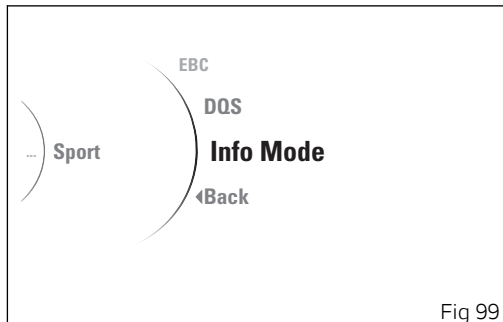

Fig 99

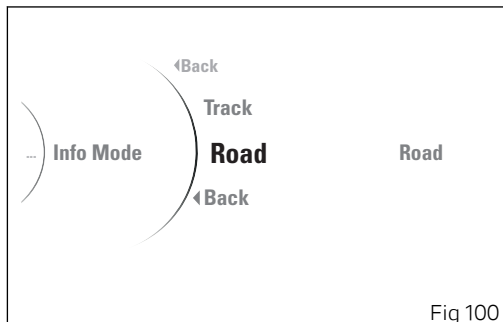

Fig 100

SETTING MENU - Riding Mode - Default

This function restores all parameters for a single riding mode and is only available if one or more parameters have been previously modified, compared to factory settings.

- Enter the SETTING MENU.
- Use the navigation buttons to select "Riding Mode" option and press ENTER button.
- Select the required Riding Mode and press ENTER button.
- Select the "Default" option and press ENTER button to set all parameters to default values.

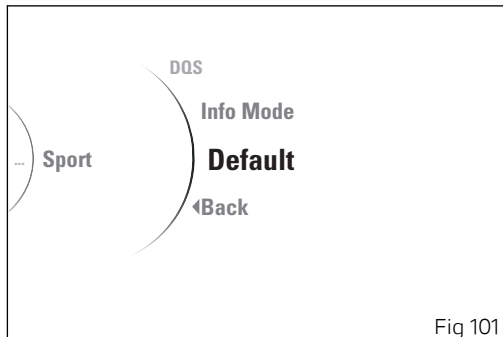

Fig 101

SETTING MENU - Riding Mode - All Default

This function restores all parameters for all riding modes and is only available if one or more parameters have been previously modified, in one or more riding modes, compared to factory settings.

- Enter the SETTING MENU.
- Use the navigation buttons to select "Riding Mode" option and press ENTER button.
- Select the "All Default" option and press ENTER button to set all parameters to default values.

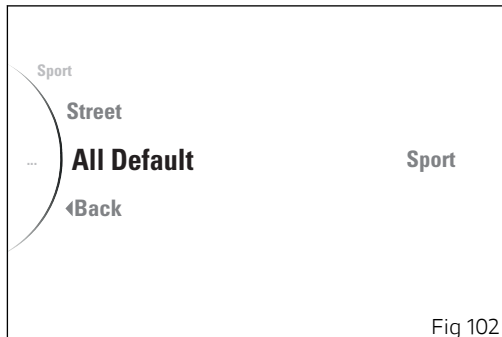

Fig 102

SETTING MENU - Pin Code

This function allows the user to activate or modify the Pin Code.

The Pin Code is initially not present in the motorcycle, it must be activated by the user by entering his/her 4-digit PIN in the instrument panel, otherwise the motorcycle cannot be started temporarily in the case of a malfunction.

In order to temporarily start the motorcycle in case of malfunction, please refer to the procedure called "Restoring motorcycle operation via the Pin Code".

Attention

The Pin Code must be activated and stored by the vehicle owner. If a Pin Code is already set, please contact your Ducati authorised dealer to reset it. The Ducati authorised dealer may ask you to demonstrate that you are the owner of the motorcycle.

- Enter the SETTING MENU.
- use the navigation buttons to select "Pin Code" option and press ENTER button.

If the Pin Code has never been activated, this menu will include "New Pin" item to activate it. While if the Pin Code has already been activated, this menu will

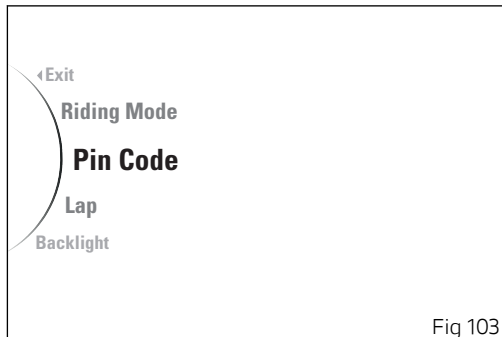

Fig 103

include "Modify Pin" item, which allows modifying the already stored pin.

New Pin

- Enter the **SETTING MENU**.
- Select the "Pin Code" option and press **ENTER** button.
- Select the "New Pin" option and press **ENTER** button.

The display shows the message "New Pin" and the spaces to enter the four digits of the new pin (Fig 105). The two arrows above and below the first digit give the possibility to set it. Entering the code:

- Use **UP** and **DOWN** buttons to increase and decrease by 1 the value from "0" to "9".
- Press **ENTER** button to confirm the digit and move on to the following digit.
- Repeat the procedure until entering all 4 digits.

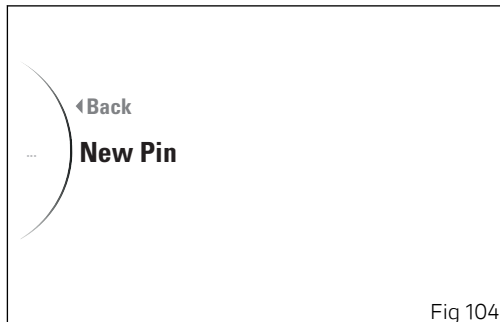

Fig 104

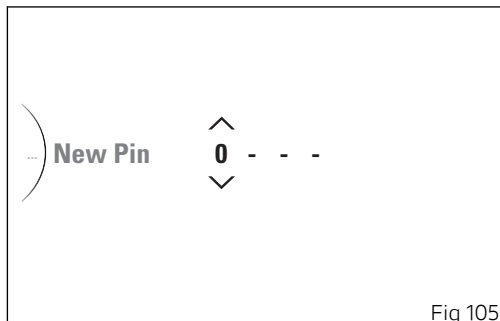
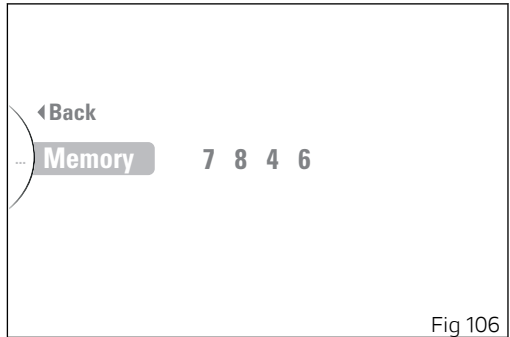

Fig 105

Once the fourth and last digit is set, press ENTER and the orange message "Memory" will be displayed. Press again ENTER to store the entered code: green "Memorized" indication will be displayed for 2 seconds. The instrument panel will display again the Pin Code home menu, and show "Modify Pin" instead of "New Pin" option.



Modify Pin

- Enter the SETTING MENU.
- Select the "Pin Code" option and press ENTER button.
- Select the "Modify Pin" option and press ENTER button.

The display shows the message "Old Pin" and the spaces to enter the four digits of the old pin (Fig 105). The two arrows above and below the first digit give the possibility to set it. Entering the code:

- Use UP and DOWN buttons to increase and decrease by 1 the value from "0" to "9".
- Press ENTER button to confirm the digit and move on to the following digit.
- Repeat the procedure until entering all 4 digits.

Once the fourth digit is set, press ENTER and the instrument panel behaviour will be as follows:

- if the pin code is not correct, the instrument panel displays "Wrong" highlighted in red for 2 seconds and then goes back to previous screen, to allow you to try again;
- if the pin code is correct, the instrument panel shows "Correct" highlighted in green for 2 seconds, and then displays the page for entering

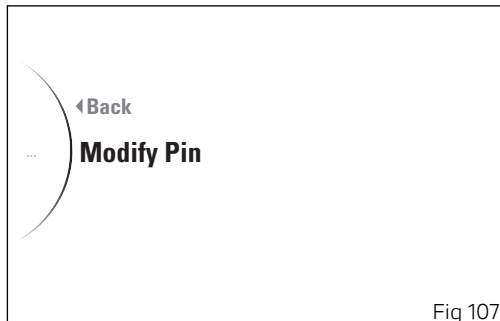

Fig 107

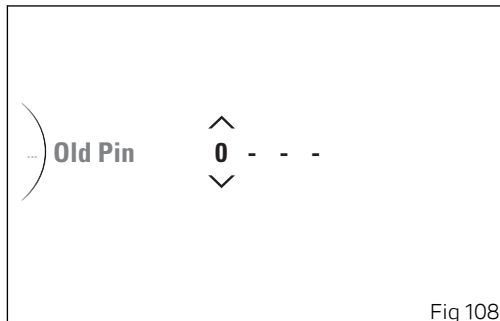

Fig 108

the new Pin Code. In this case, refer to description under "New Pin" sub-paragraph, to enter a new code.

SETTING MENU - Lap

This function allows enabling or disabling the LAP function and view and delete the recorded LAPs.

- Enter the SETTING MENU.
- Use the navigation buttons to select "Lap" option and press ENTER button.

In this menu the function current status is displayed on the right side and the following items on the left side:

- "Off" to disable the LAP function.
- "On" to enable the LAP function.
- "Lap Data" to view the stored laps.
- "Erase All" to delete all memorised LAPs (visible only if there are memorised LAPs).

Select the desired indication by pressing the navigation buttons and press ENTER button to activate the relevant function.

According to whether the GPS EVO is installed or not, the "Lap Data" function shows the recorded times in LAP BASIC or LAP EVO mode.

Any time the key is turned on, the Lap function is set to "Off".

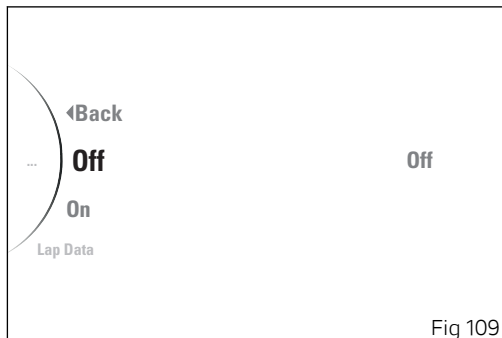

Lap Data (LAP BASIC mode)

- Enter the SETTING MENU.
- Use the navigation buttons to select "Lap" option and press ENTER button.
- Select the "Lap Data" option and press ENTER button.

When accessing this function, the display shows "Best Laps" and the available LAPs from 1 to 30. Use the navigation buttons to scroll through the memorised LAPs.

Data recorded for each lap are:

- "Time" - the lap time (up to maximum 8'59"00);
- "Real Speed (max)" - the maximum real speed reached and the set unit of measurement;
- "RPM (max)" - the maximum engine rpm reached.

Select "Best Laps" to view the best lap time data among the recorded ones.



Note

It is possible to record maximum of 30 LAPs.

If there are no memorised LAPs, when accessing this menu the instrument panel will show "No Lap".

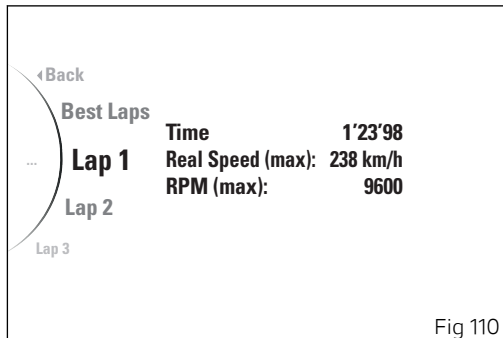

Fig 110

To activate the Lap recording, refer to chapter "Lap time (Lap)".

Lap Data (LAP EVO mode)

- Enter the SETTING MENU.
- Use the navigation buttons to select "Lap" option and press ENTER button.
- Select the "Lap Data" option and press ENTER button.

When accessing this function, the display shows "Best Laps" and the recorded sessions (max. 4). To view the LAPs memorised in one session, select the desired session and press ENTER.

The display will show all the LAPs recorded in the selected session (Fig 112).

Use the navigation buttons to scroll through the memorised LAPs.

Data recorded for each lap are:

- "Time" - the lap time (maximum time: 8'59"00);
- "Intertime 1" - if the first split time point has been configured (maximum time: 8'59"00);
- "Intertime 2" - if the second split time point has been configured (maximum time: 8'59"00);
- "Real Speed (max)" - the maximum real speed reached and the set unit of measurement (the speed is detected via GPS EVO);
- "RPM (max)" - the maximum engine rpm;

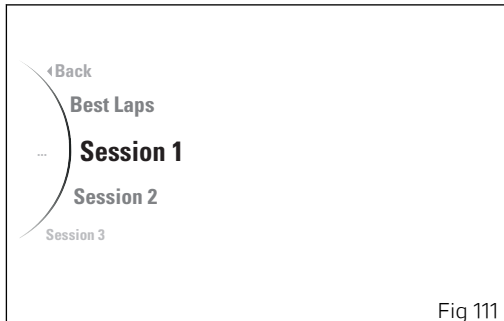

Fig 111

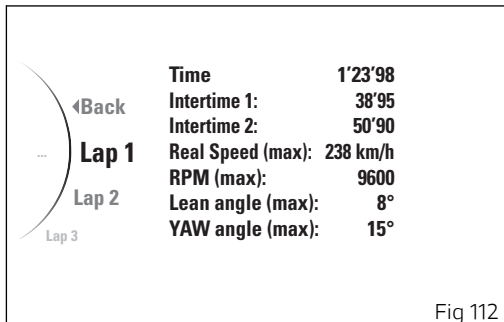

Fig 112

- “Lean angle (max)” - maximum reached lean angle;
- “YAW angle (max)” - maximum reached yaw angle.

Select “Best Laps” (Fig 111) to view the best lap time data recorded in each sessions.



Note

It is possible to record maximum of 30 LAPs divided into 4 sessions.

If there are no memorised LAPs, when accessing this menu the instrument panel will show “No Lap”. To configure the split times and record the Laps/sessions, refer to chapter “Lap time (Lap)”.

Erase All

- Enter the SETTING MENU.
- Use the navigation buttons to select "Lap" option and press ENTER button.
- Select "Erase All" and press ENTER.

When accessing this function, the display shows "Erase All": to delete all recorded LAPs, select the indicated item and keep the ENTER button pressed for 2 seconds. The message "Wait..." is displayed for 3 seconds on the right side, then the instrument panel displays the previous menu.

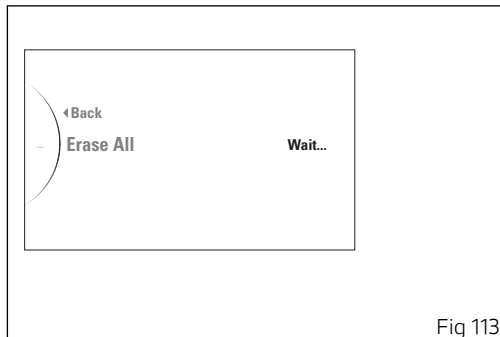

Fig 113

SETTING MENU - Backlight

This function allows setting the display day or night mode.

- Enter the SETTING MENU.
- Use the navigation buttons to select "Backlight" option and press ENTER button.

Displayed items within this menu are "Auto", "Day" and "Night", while function current status is on the RH side.

Select the required option and press ENTER button.

- "Auto" (default setting) to automatically set the background colour according to the ambient light.
- "Day" to set the white background, recommended with significant ambient light.
- "Night" to set the black background, recommended with poor ambient light or in the dark.

Note

In case of battery disconnection, the backlighting "Auto" mode is automatically set.

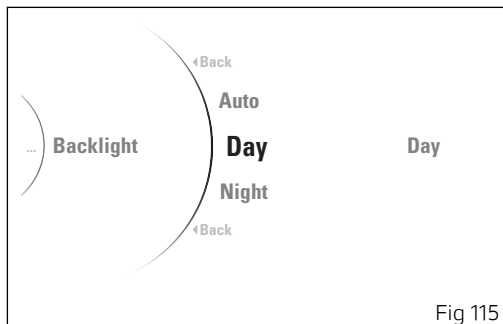
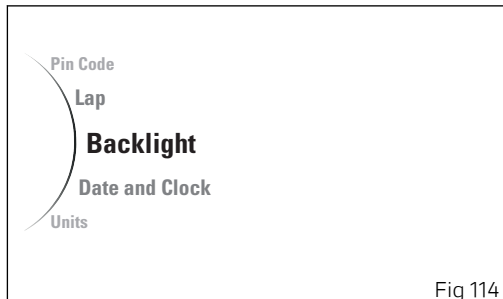

SETTING MENU - Date and Clock

This function allows setting date and time.

- Enter the SETTING MENU.
- Use the navigation buttons to select "Date and Clock" option and press ENTER button.

This menu includes "Date" and "Clock" options, while currently set date and time are displayed at the centre.

Select the required option and press ENTER button.

Note

If the date or time have never been set, a string of dashes "-" is displayed instead of the corresponding values.

Date and time must be set again after battery disconnection.

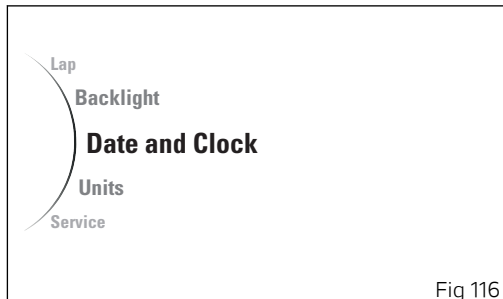

Fig 116

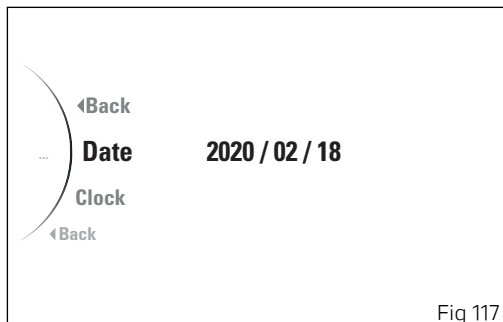
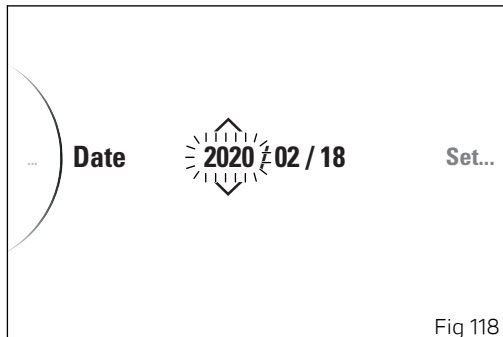

Fig 117

Date (date setting)

- Enter the SETTING MENU.
- Use the navigation buttons to select "Date and Clock" option and press ENTER button.
- Select the "Date" option and press ENTER button.
- "Set..." is displayed on the right side while the year flashes at the centre. Set the year using the UP or DOWN buttons.
- Press ENTER button to confirm the year.
- The month flashes. Set the month using the UP or DOWN buttons.
- Press ENTER button to confirm the month.
- The day flashes. Set the day using the UP or DOWN buttons.
- Press ENTER button to confirm the day and save set date.

If date is not correct, the instrument panel will display "Wrong" for 3 seconds and then it will automatically go back to setting the year and repeat date setting.



Clock (time setting)

- Enter the SETTING MENU.
- Use the navigation buttons to select "Date and Clock" option and press ENTER button.
- Select the "Clock" option and press ENTER button.
- "Set..." is displayed on the right side while "AM" or "PM" flashes at the centre. Set the parameter using the UP or DOWN buttons.
- Press ENTER button to confirm.
- The hour flashes. Set the hour using the UP or DOWN buttons.
- Press ENTER button to confirm.
- The minutes flash. Set the minutes using the UP or DOWN buttons.
- Press ENTER button to confirm and save set time.

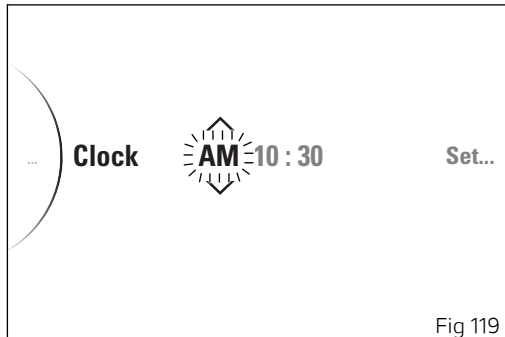

Fig 119

SETTING MENU - Units

This function allows setting the units of measurement used by the instrument panel.

- Enter the SETTING MENU.
- Use the navigation buttons to select "Units" option and press ENTER button.
- The following options will be displayed in this menu: "Speed", "Temperature", "Consumption", "All Default" (visible only if one or more parameters are different from the default ones).
- Select the required option and press ENTER button.

Note

When changing the units of measurement, except the temperature, the functions TRIP 1, TRIP 2, CONS. AVG 1, SPEED AVG 1 and TRIP TIME 1 are automatically reset.

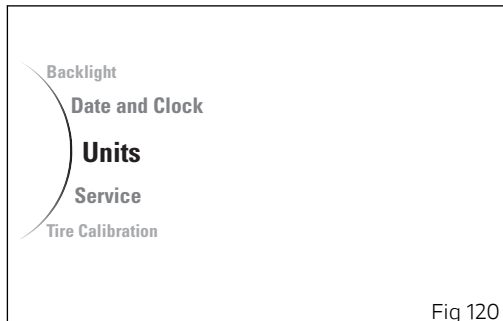

Fig 120

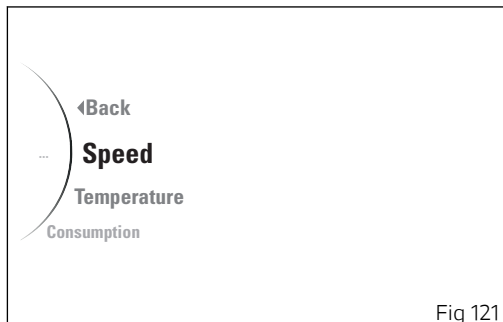

Fig 121

Speed

- Enter the SETTING MENU.
- Use the navigation buttons to select "Units" option and press ENTER button.
- Select the "Speed" option and press ENTER button.
- Options "km/h", "mph" and "Default" are listed (visible only if currently set unit of measurement is not the default one). The currently set unit of measurement is shown on the right-hand side of the display.
- Using the navigation buttons, it is possible to select the desired unit of measurement or the "Default" option to restore the default unit of measurement.
- Press ENTER button to confirm.

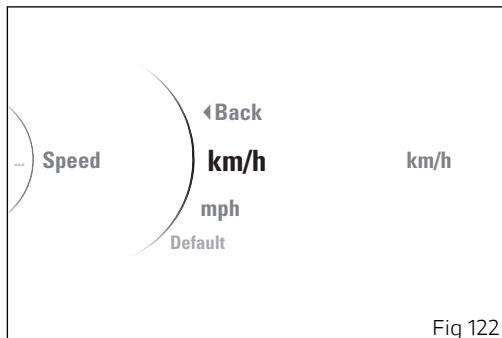

Fig 122

Temperature

- Enter the SETTING MENU.
- Use the navigation buttons to select "Units" option and press ENTER button.
- Select the "Temperature" option and press ENTER button.
- Options "°C", "°F" and "Default" are listed (visible only if currently set unit of measurement is not the default one). The currently set unit of measurement is shown on the right-hand side of the display.
- Using the navigation buttons, it is possible to select the desired unit of measurement or the "Default" option to restore the default unit of measurement.
- Press ENTER button to confirm.

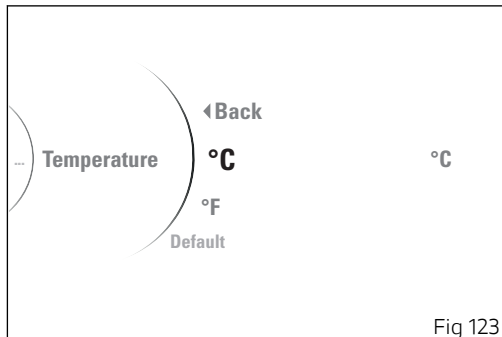
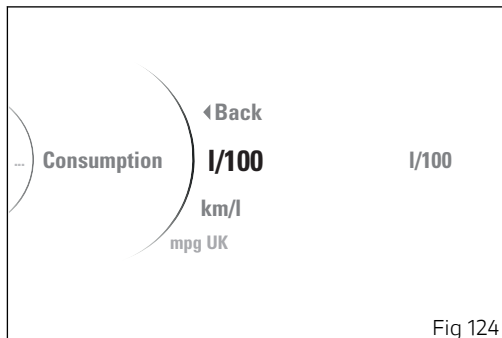

Fig 123

Consumption

- Enter the SETTING MENU.
- Use the navigation buttons to select "Consumption" option and press ENTER button.
- Select the "Temperature" option and press ENTER button.
- Options "l/100", "km/l", "mpg UK", "mpg US" and "Default" are listed (visible only if currently set unit of measurement is not the default one). The currently set unit of measurement is shown on the right-hand side of the display.
- Using the navigation buttons, it is possible to select the desired unit of measurement or the "Default" option to restore the default unit of measurement.
- Press ENTER button to confirm.



SETTING MENU - Service

This function allows displaying next Services.

- Enter the SETTING MENU.
- Use the navigation buttons to select "Service" option and press ENTER button.
- The display shows the information concerning the following Service types:
 - Oil Service (remaining mileage)
 - Desmo Service (remaining mileage)
 - Annual Service (date)

This function does not allow any kind of changes. Press ENTER button to quit.

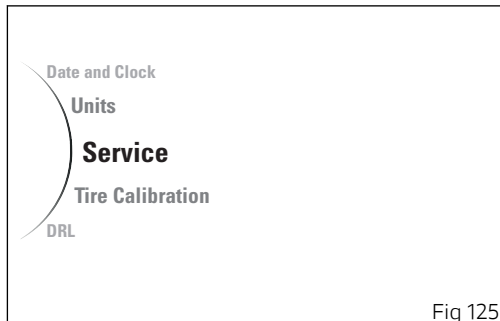

Fig 125

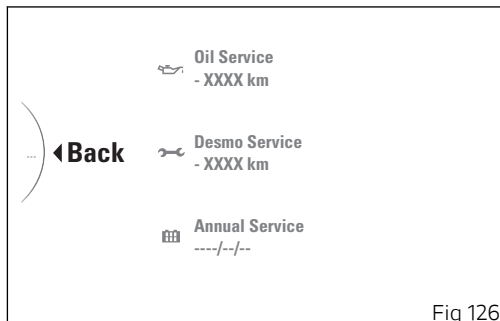

Fig 126

SETTING MENU - Tire Calibration

This function allows the user to run the procedure for calibrating and teaching in the tyre rolling circumference and final drive ratio.

- Enter the SETTING MENU.
- Use the navigation buttons to select "Tire Calibration" option and press ENTER button.

This menu includes the options "Start" and "Default" (visible only if user set a calibration different from the default one).

Select the required option and press ENTER button.

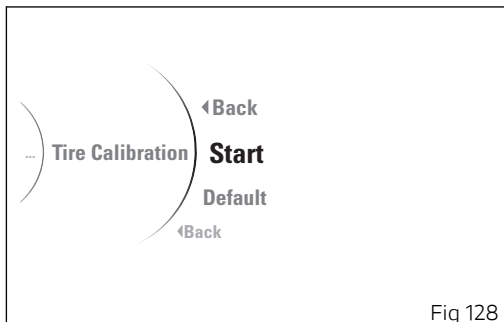
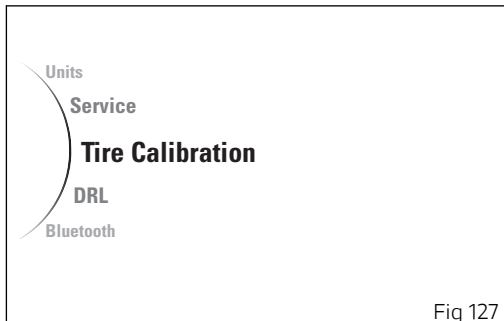

Start

- Enter the SETTING MENU.
- Use the navigation buttons to select "Tire Calibration" option and press ENTER button.
- Select the "Start" option and press ENTER button.

When the calibration procedure starts, the instrument panel displays the message "Ready" flashing, the message "Keep Speed" with speed range and the gear to be maintained by the user to complete the teach-in procedure. On the RH side is the reference Riding Mode, current speed and gear engaged.

Important

The teach-in procedure is allowed only at a vehicle speed between 49 Km/h (30 mph) and 51 Km/h (32 mph) in the 2nd gear.

When the rider complies with the required conditions of speed and gear indicated, the instrument panel starts system calibration: all previous information will be displayed showing "In progress" instead of "Ready". Calibration is performed by keeping speed and gear within the indicated range for 5 seconds.

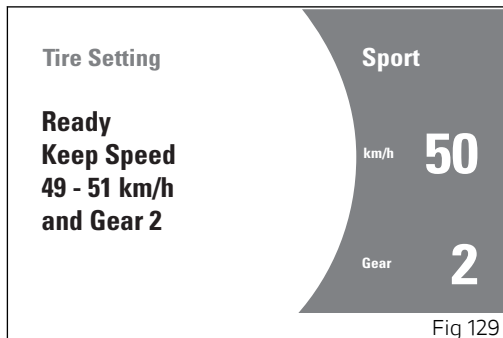

The procedure can be aborted by holding depressed the UP button for 2 seconds: in this case the instrument panel shows displays all previous information, replacing message "In progress" with message "Aborted", followed by the previous menu after a few seconds.

If the teach-in procedure is completed correctly, the instrument panel shows "Completed" followed by the previous menu after a few seconds.

If the calibration procedure is aborted by the user, the instrument panel shows "Aborted" followed by the previous menu after a few seconds.

If, on the other hand, an error or malfunction occurs during the calibration procedure, the instrument panel shows "Failed" followed by the previous menu after a few seconds.

Note

During the calibration procedure, the procedure will stop if the vehicle speed exceeds 100 km/h (62 mph) or the key is turned off.

Default

- Enter the SETTING MENU.
- Use the navigation buttons to select "Tire Calibration" option and press ENTER button.
- Select the "Default" option and press ENTER button to restore default values.
- The message "Default Please Wait.." is displayed and after a while "Default Ok" for 2 seconds, then followed by the previous menu.

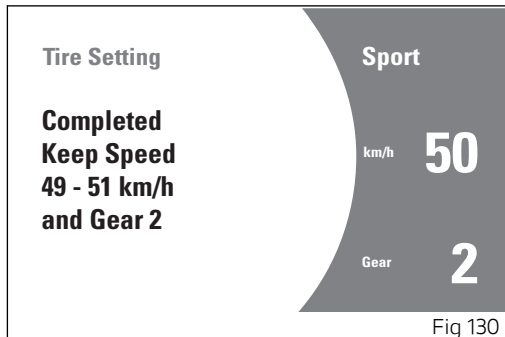

SETTING MENU - DRL

This function allows user to set the DRL lights in automatic or manual mode.

- Enter the SETTING MENU.
- Use the navigation buttons to select "DRL" option and press ENTER button.

Displayed items within this menu are "Auto" and "Manual", while function current status is on the RH side.

Select the required option and press ENTER button.

Note

In case of battery disconnection, the "Auto" mode is automatically set.



Fig 131

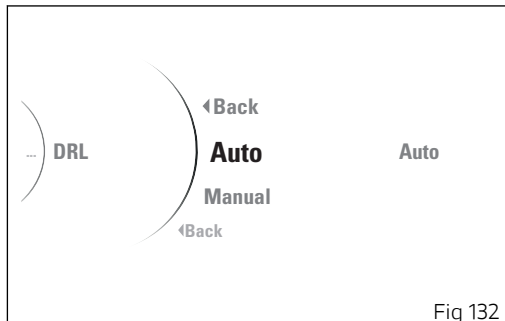

Fig 132

Removing the filler plug lock

This function allows the user to manage any paired Bluetooth devices and add more. This function is only available if the Bluetooth module is installed to the bike.

- Enter the SETTING MENU.
- Use the navigation buttons to select "Bluetooth" option and press ENTER button.

This menu includes the "Associated Devices" option to view and delete any paired devices and the "Pairing" option to pair a new device. Select the required option and press ENTER button.

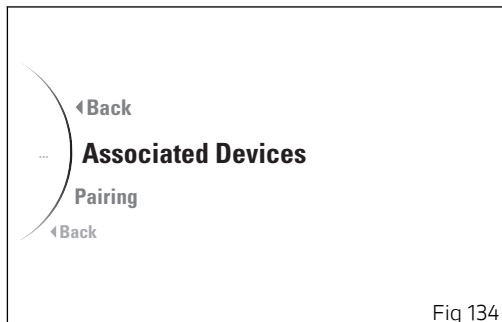
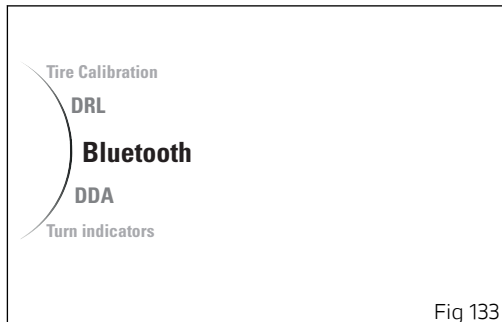

Associated Devices

This function allows viewing and erasing paired devices.

- Enter the SETTING MENU.
- Use the navigation buttons to select "Bluetooth" option and press ENTER button.
- Select the "Associated Devices" option and press ENTER button.
- All paired devices are listed. Select the required device and press ENTER button.
- The message "Delete" is displayed, select it and press ENTER button to delete the selected device from the list.
- The message "Wait..." is displayed for a few seconds, then the instrument panel displays the previous menu.

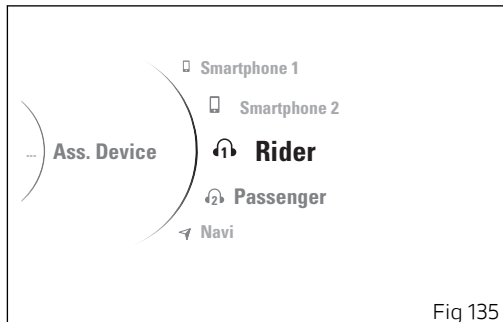

Fig 135

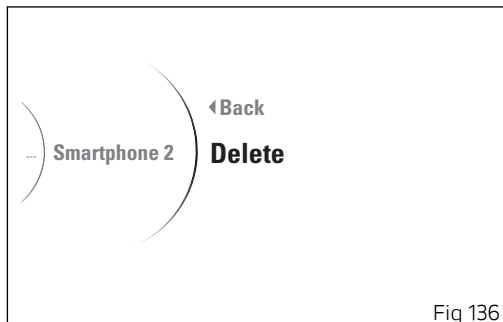

Fig 136

Pairing

This function allows pairing a new Bluetooth device. The instrument panel manages 4 types of Bluetooth devices and a maximum of 5 devices paired and/or connected: 2 smartphones, 1 rider earphone, 1 passenger earphone, 1 navigator.

Note

Before pairing a new device, make sure that its Bluetooth connection is active and that it can be detected by other Bluetooth devices. Always refer to the provisions under the device instructions.

Note

During the pairing procedure user may be required to confirm it directly on the device (e.g. smartphone). Refer to the device messages.

- Enter the SETTING MENU.
- Use the navigation buttons to select "Bluetooth" option and press ENTER button.
- Select the "Pairing" option and press ENTER button.
- The list of the 4 types of devices that can be managed by the instrument panel is displayed.

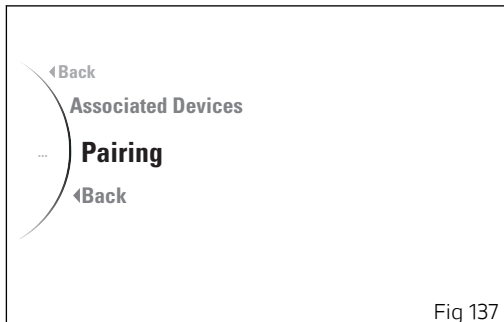

Fig 137

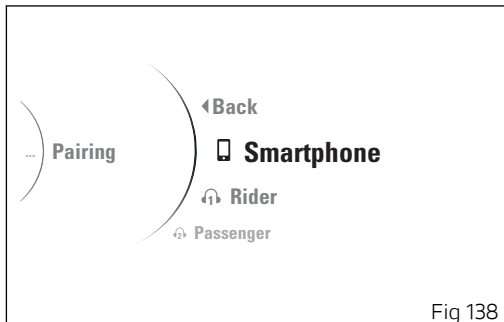

Fig 138

Select type of device to be paired and press ENTER button.

- The instrument panel starts searching for nearby Bluetooth devices, and displays the message "Wait..." followed by a list of detected devices.
- As soon as the search stage is over, system gives out a list of all detected devices. Use the navigation buttons to select the required device and press ENTER button.
- The display shows the message "Pairing..." on the right, while waiting validation by the Bluetooth device.

If device pairing is successful, the display will show previous menu page. If not, the message "Pairing Error" is displayed and user is allowed to repeat the pairing procedure.

Attention

Ducati does not ensure a correct connection to the Ducati Multimedia System of Bluetooth navigators that are not provided in the following kits:

- Kit of Ducati Zumo satellite navigator 350
- Kit of Ducati Zumo satellite navigator 390
- Kit of Ducati Zumo satellite navigator 395



Note

The Ducati kits mentioned above can be purchased separately at a Ducati Dealer or Authorised Service Centre.



Attention

Smartphone and Bluetooth Headset device manufacturers may incorporate certain changes within the standard protocols over the course of the lifecycle of the device (Smartphones and Earphones).



Attention

These changes are outside the control of Ducati and may result in Bluetooth Headset devices functionality becoming impaired (sharing Music, multimedia player, etc.) and may equally affect some types of Smartphones (depending on supported Bluetooth profiles). This is why Ducati cannot guarantee multimedia player proper operation for:

- any earphones not coming with the "Ducati Kit part no. 981029498";
- any Smartphones not supporting the required Bluetooth profiles (even though paired to earphones coming with the "Ducati Kit part no. 981029498").



Attention

In case of interference or noise due to particular conditions of the external environment, the Ducati earphone kit part no. 981029498 also allows sharing the music being played directly from rider helmet to passenger helmet (for further details please refer to the manual of the earphones coming with the Ducati kit part no. 981029498).



Note

The Ducati kit part no. 981029498 can be purchased separately at a Ducati Dealer or Authorised Service Centre.

SETTING MENU - DDA

This function allows you to enable and disable the DDA, view the percentage of memory used and to delete data stored in the DDA memory.

- Enter the SETTING MENU.
- Use the navigation buttons to select "DDA" option and press ENTER button.

Displayed items within this menu are "Off", "On" and "Memory", while function current status is on the RH side.

Select the required option and press ENTER button.

Note

The DDA is automatically disabled by the instrument panel upon every Key-OFF.

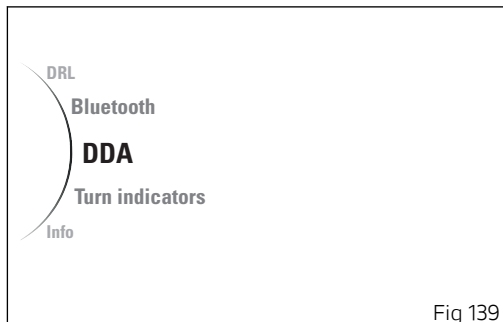

Fig 139

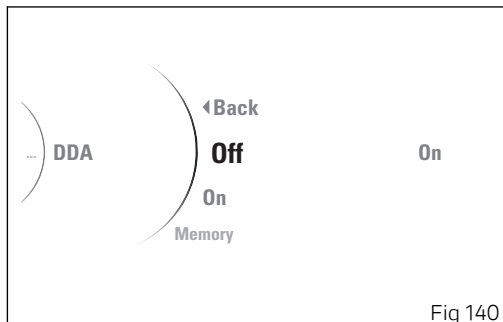

Fig 140

Memory

This function allows viewing and erasing DDA stored information.

- Enter the SETTING MENU.
- Use the navigation buttons to select "DDA" option and press ENTER button.
- Select the "Memory" option and press ENTER button.

When opening the function, the message "Empty" will be displayed if memory is empty. If not, memory status is displayed as a percentage and a progress bar, together with item "Erase". The message "Full" will be displayed if memory is full.

Select "Erase" option and press ENTER button to delete all stored data.

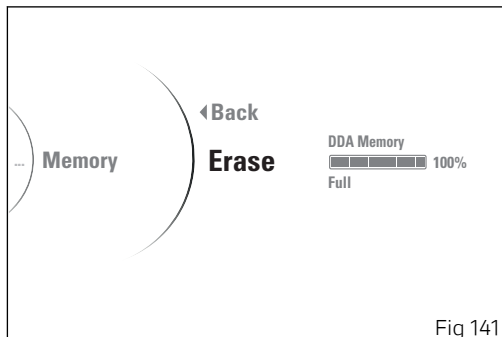

Fig 141

SETTING MENU - Turn indicators

This function allows user to set the turn indicators to automatic mode or manual mode.

The turn indicator automatic switch-off strategy is implemented based on calculation of leaning angle, vehicle speed and run distance.

- Enter the SETTING MENU.
- Use the navigation buttons to select "Turn indicators" option and press ENTER button.

Displayed items within this menu are "Auto" and "Manual", while function current status is on the RH side.

Select the required option and press ENTER button.

Note

In case of battery disconnection, the "Auto" mode is automatically set.

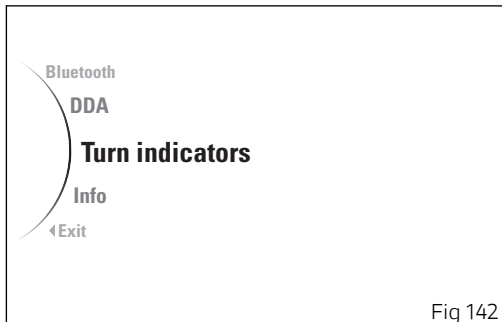

Fig 142

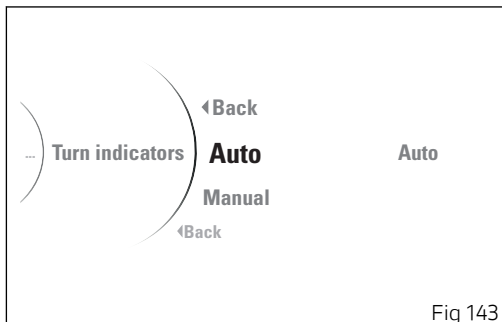

Fig 143

SETTING MENU - Info

This function allows viewing the vehicle battery voltage and the engine rpm digital indication.

- Enter the SETTING MENU.
- Use the navigation buttons to select "Info" option and press ENTER button.
- The display shows the information concerning the battery and engine rpm in a digital format.

This function does not allow any kind of changes. Press ENTER button to quit.

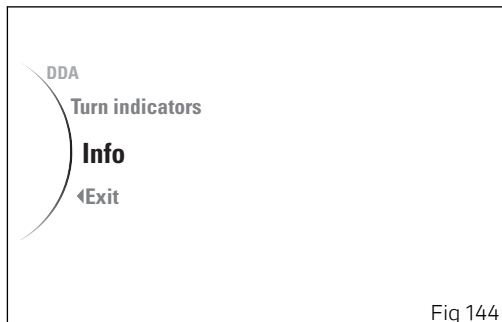

Fig 144

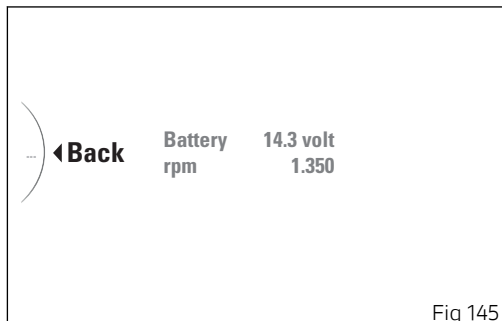

Fig 145

Lap time (LAP)

The LAP function and the relevant Lap time recording are only available in the TRACK display mode.

According to whether the GPS is installed or not, the motorcycle can have two types of LAPs:

- LAP BASIC if the GPS is missing or not installed on the motorcycle in the basic version
- LAP EVO if the motorcycle is equipped with the GPS EVO

For both types of LAP, upon the function activation the display shows:

- the timer at 0'00.00;
- the LAP number starting from "Lap --/30" in case of LAP BASIC;
- the current session number starting with "Session 1" and the LAP number starting with "Lap --/30", in case of LAP EVO.

LAP BASIC without GPS module

If there is no GPS module on the motorcycle, timer can be started and stopped by pressing the FLASH button after activating the LAP function:

- when pressing FLASH once, both timer (that starts) and lap number (which will become "Lap 01") will flash for 1 second;
- when pressing the FLASH button some more times, the just recorded time and lap will flash for one second and remain displayed for another 5 seconds; after this period of time the function displays again the timer and lap progressive number.

For each lap, the following data are stored:

- Lap time
- maximum reached speed;
- maximum reached rpm.

Note

It is possible to record maximum of 30 LAPs.

Note

The FLASH button is not considered if pressed within 5 seconds from when a new lap is recorded.

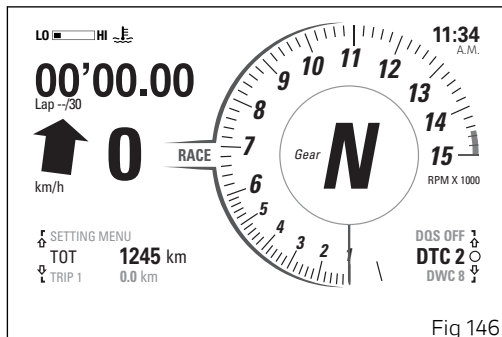

LAP BASIC with GPS module

If there is a GPS module on the motorcycle, the timer start and stop is managed automatically by the instrument panel after activating the LAP function. The display shows GPS (A) symbol further to timer and lap number.

When lap one starts, press FLASH to start the timer: both timer (that starts) and lap number (that will become "Lap 01") will flash for 1 second. At the same time, the instrument panel stores finish-line position via the GPS control unit and activates the symbol (B): all the following laps will be directly recorded by the instrument panel and the FLASH button is no longer used for the timer start/stop function.

Any time the bike reaches the finish-line position as recorded by the instrument panel, the just recorded time and lap will flash for one second and remain displayed for another 5 seconds; after this period of time the function displays again the timer and lap progressive number.

For each lap, the following data are stored:

- Lap time
- maximum reached speed;

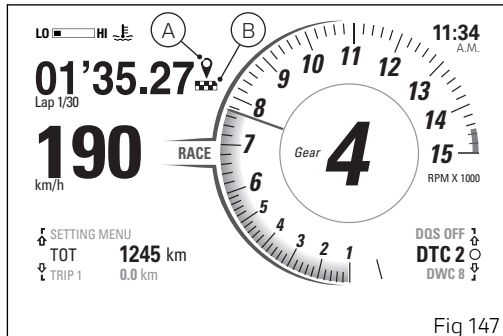

Fig 147

- maximum reached rpm.



Note

It is possible to record maximum of 30 LAPS.

LAP EVO

If the bike is equipped with the GPS EVO module, the LAP EVO function is enabled. The display shows GPS (A) symbol further to timer and lap number.

Unlike the LAP BASIC, the LAP EVO allows recording the finish-line position and 2 splits. Once the finish-line coordinates and splits are recorded, the LAPs are managed by the GPS.

To set the finish-line coordinates and the splits it is necessary to:

- position the bike on the finish-line and press the FLASH button to record the coordinates; the symbol (B) is displayed;
- position the bike on the first split and press the FLASH button to record the coordinates; the symbol (C) is displayed;
- position the bike on the second split and press the FLASH button to record the coordinates; the symbol (D) is displayed.

The set coordinates remain recorded also after a key-off.

To change the coordinates of one or more positions, repeat the recording procedure described above by respecting the order: FINISH-LINE – SPLIT 1 – SPLIT 2.

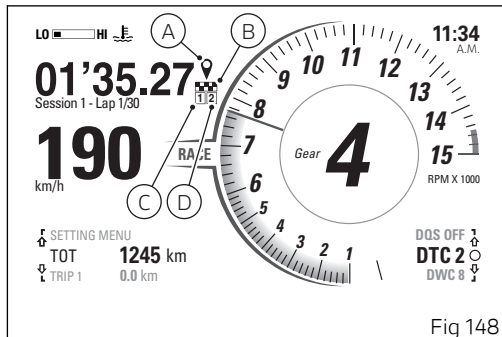

Fig 148

The coordinates are deleted automatically when the instrument panel detects that the motorcycles moves by more than 15 km away from the memorised coordinates.

The LAP EVO allows recording maximum 30 LAPs that can be divided into up to 4 sessions. Upon each key-on, when the LAP function is activated, the instrument panel enables a new session.

Once session 4 is reached, in case of key-on the instrument panel continues the LAP recording in session 4.

When the 30th LAP is reached, the display will show "FULL".

To delete the recorded sessions and LAPs, refer to chapter "SETTING MENU - Lap".

For each lap time, the LAP EVO function allows recording the following parameters:

- Lap time
- split 1
- split 2
- maximum reached speed detected through GPS EVO
- maximum reached rpm
- maximum reached lean angle
- maximum yaw angle

The following notes are to be considered valid for both LAP types.

 **Note**

If bike speed is equal to 0, after 5 seconds from lap time recording start, the instrument panel stops the time recording by resetting the timer.

 **Note**

If during a time recording the motorcycle is stopped or the speed goes below 5 km/h (3 mph), the instrument panel stops the recording and resets the timer automatically.

 **Note**

Any time you record a new lap time, if it is better than those previously memorised, the lap timer flashes quickly for 6 seconds, otherwise the timer flashes quickly only for 1 second. Best lap time is calculated only if at least 2 lap times have been recorded.

 **Note**

If the LAP function is active, the instrument panel memorises the status upon the key-off. If the key is turned off during a Lap time recording, upon the next key-on the instrument panel stops and resets the timer.

 **Note**

When the timer is started, if the time exceeds 07'59.99, it is reset and starts the count from 00'00.00.

Assisted start (DPL)

This function allows activating the assisted start (called DPL - Ducati Power Launch).

By pressing the DPL button it is possible to access the Launch Control menu only if the vehicle speed is equal to or less than 5 Km/h (3 mph).

In the Launch Control menu, it is possible to select the desired DPL level (1, 2, 3) by pressing the UP and DOWN buttons, and to set the selected level by keeping the ENTER button pressed for 2 seconds.

Note

If no change is made in this menu within ten seconds, the instrument panel will set DPL to OFF and go back to the previous screen.

Note

If the instrument panel detects a control unit error when entering the DPL menu, it will show the blinking message "Launch Control Error" for three seconds and then again the main screen.

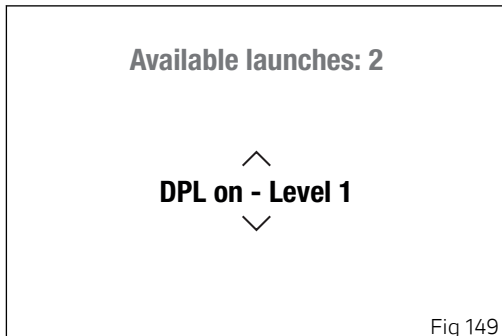

Note

If the available launches are finished, the instrument panel shows the message "No launches available".

Once the DPL level is set, the instrument panel shows the wait screen for 2 seconds (Fig 150): during this time, if you press the ENTER button, the wait phase is interrupted and the instrument panel displays the main screen and sets the DPL to OFF. Then the instrument panel shows the "assisted launch" screen (Fig 151).

After the assisted start, the instrument panel sets the DPL to OFF and shows the "main screen" again. The DPL is set to OFF by default by Ducati.

If the DTC is set to "Off" and you press the DPL button, the instrument panel shows for 5 seconds the indication "DTC off – DPL not available" and then the instrument panel goes back to the main screen.

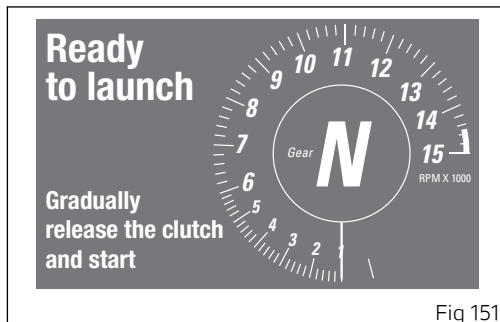
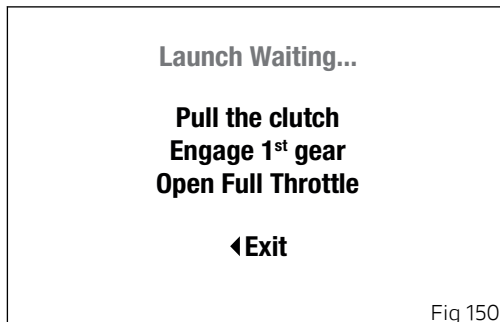

The Ducati Power Launch (DPL) helps the rider in the delicate sport starting phase from a standstill to control the power delivered by the vehicle.

The DPL system works with three intervention levels, each calibrated to offer a different start assist degree. The following table indicates the most suitable DPL intervention level depending on the various starting types. All levels are to be intended optimised for OEM (Original Equipment Manufactured) tyres.

DPL level	Performance	Use
1	High	Use focused on the best performance for very expert riders. The system allows the wheelie and the rear wheel slipping, but reduces the speed at which these two situations take place.
2	Medium	Use for expert riders. The system reduces the tendency to wheelie and rear wheel slipping, besides intervening considerably in case these two situations take place.
3	Medium	Use for all kinds of riders. The system minimises the tendency to wheelie and rear wheel slipping, besides intervening considerably in case these two situations take place.



Attention

The DPL system is to be used exclusively on straight and level paths, on optimal grip conditions of the road.

The DPL system is conceived to be used within a controlled environment or in a closed circuit. For safety reasons it must not be used in unsuitable places.

Starting procedure

The starting procedure basically consists of two phases:

- The first: with completely released clutch so that the torque transmitted to the ground depends on the clutch position and slipping;
- The second: with clutch not released so that the torque transmitted to the ground depends on the torque delivered by the engine.

The DPL system helps the rider to start from a standstill and during the first phase by automatically adjusting the torque delivered by the engine to keep the engine rpm at the ideal value to start. This allows the rider to concentrate only on the clutch release that must be progressive and "smooth" instead of fast or abruptly. The engine torque is adjusted also in

the second phase, by maximising the delivered power and limiting the vehicle wheeling or rear wheel slipping.

To preserve the clutch, the DPL system calculates in real time and shows in the dedicated menu on the instrument panel the number of starts that can be performed consecutively by decreasing it by one unit every time a start is completed. The DPL system increases the value by one unit according to the distance covered by the vehicle and the time during which the vehicle engine was on and off.

The DPL system allows performing other assisted starts only when the number of remaining starts is higher than zero.



Attention

Using the DPL system could reduce the useful life of the engine and transmission mechanical parts. The DPL system should be used only when the engine has reached the operating temperature.

To perform an assisted start with the DPL, the rider must first of all set the vehicle in the following condition:

- vehicle speed at zero;
- vertical position;
- engine on;

- DTC set to ON.

If the count of the residual assisted starts is above zero, the rider can select on the instrument panel the desired DPL level by accessing the relevant menu through the dedicated button.

After selecting the level, the rider must pull the clutch, engage the first gear and fully open the throttle twistgrip.

If all operations indicated above have been performed, the DPL system will show a confirmation screen on the instrument panel indicating that the system is ready to start. The rider must then release the clutch progressively by keeping the throttle twistgrip fully open. When the vehicle speed exceeds 20 km/h, the instrument panel shows the standard screen while keeping the indication of the selected DPL system level for the entire duration of the start phase.

The DPL system is switched off when one of the following conditions is met after completely releasing the clutch:

- vehicle speed higher than 160 km/h;
- third gear engaged.

The DPL system is switched off also if, after releasing the clutch, the rider decides to interrupt the start phase by closing the throttle and bringing the vehicle speed under 5 km/h.



Attention

The system manages the power delivered by the engine but not the clutch lever release that remains under the control of the rider.

During the starting phase, an abrupt release of the clutch will prevent an optimal behaviour of the vehicle. Likewise, a prolonged activation of the clutch may overheat and thus damage it.



Attention

The rider position on the bike may influence the system behaviour.

Tips on how to select the intervention level

If level 3 is set, the DPL system intervenes by reducing the tendency to wheelie or rear wheel slipping during the starting phase. Levels 2 and 1 provide a limited intervention of the system.

To identify the DPL level most suitable to your riding style we recommend to activate the system, select level 3 and perform a start to become familiar with

the system. Then we recommend to try levels 2 and 1 in sequence until finding the best intervention.

If non-OEM tyres of a different size class are used or if the tyre size differs significantly from the original tyres, it may be that the system operation is compromised.

As far as tyres are concerned, in the case of minor differences such as, for example, tyres of a different make and/or model than the OE ones, it is necessary to use the relevant automatic calibration function in order to restore correct system operation.



Attention

The DPL is a rider assist system. The system is designed to make riding easier and to enhance safety, but in no way relieves the rider of the obligation to drive responsibly and to maintain a high standard of riding in order to avoid accidents, whether caused by his own errors or those of other road users, through making emergency manoeuvres, in accordance with the prescriptions of the road traffic code.

The rider must always be aware that active safety systems have a preventive function. The active elements help the rider control the motorcycle, making it as easy and safe to ride as possible. The presence of an active safety system should not encourage the rider to ride at speeds beyond the reasonable limits, not in accordance with the road conditions, the laws of physics, good riding standards and the requirements of the road traffic code.

Infotainment

If the Bluetooth control unit is installed, the Bluetooth symbol is displayed on the instrument panel.

The instrument panel is equipped with an infotainment system that allows managing up to 4 types of devices connected via Bluetooth: smartphone, rider helmet intercom, passenger helmet intercom, satellite navigator. To pair or remove Bluetooth devices, refer to the chapter "SETTING MENU - Bluetooth". After connection, they are displayed as follows:

- 1) smartphone connected;
- 2) rider helmet intercom connected;
- 3) passenger helmet intercom connected;
- 4) rider helmet intercom connected and passenger helmet intercom associated;
- 5) rider helmet intercom associated and passenger helmet intercom connected;
- 6) rider and passenger helmet intercom connected;
- 7) Ducati GPS navigator connected.

Icons are light blue if the corresponding device is connected. They are grey if the corresponding device is paired but not connected.

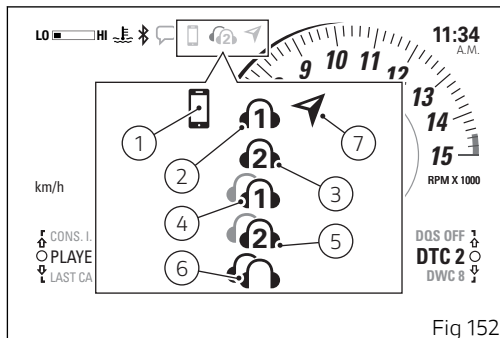

If a smartphone is connected to the instrument panel, the system allows managing the music player and the list of the last calls. Please refer to "PLAYER (OFF / ON)" and "LAST CALLS".

Below is a description of what the instrument panel will do in the following cases:

- Incoming call
- Call in progress
- Recall last number
- Missed call
- Message/e-mail received

Incoming call

When there is an incoming call, the display shows:

- the message "ACCEPT" (A)
- the name/number of the person calling (B)
- the message "DECLINE" (C)

When receiving a call, press the UP button to answer or the DOWN button to reject it.

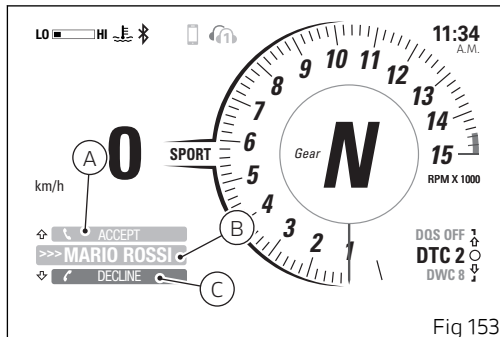

Fig 153

Call in progress

During a call, the instrument panel will display:

- ACTIVE indication (A)
- the name/number of the person calling preceded by ">>>" (B) when receiving a call, or preceded by "<<<" when making a call
- the message "END CALL" (C)

To end the call, press the DOWN button.

Note

If the rider helmet/intercom is connected in addition to the smartphone, the phone call will take place through the helmet headphones and microphone.

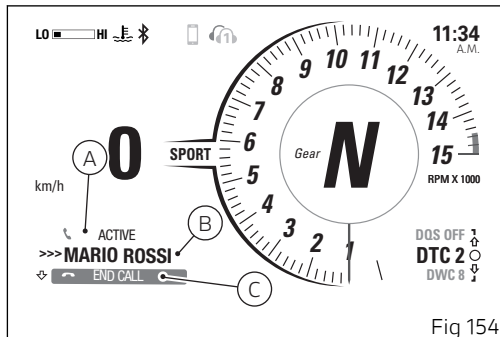

Fig 154

Recall last number

When a phone call is ended, missed or rejected, the instrument panel activates the RECALL function for 5 seconds that allows recalling the last number.

The display shows:

- the message RECALL (A)
- the name/number of the person calling preceded by <<< when making a call, or preceded by >>> when receiving a call (B)

Press the UP button to call the last name/number displayed.

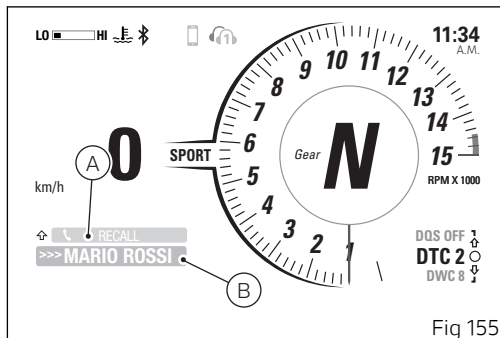

Missed call

In case of missed call, the display will show the symbol (A) for 60 seconds, flashing for the first 3 seconds.

Note

The number of missed calls is not displayed.

Message/e-mail received

In case of a received message or e-mail, the display will show the symbol (B) for 60 seconds, flashing for the first 3 seconds.

Note

The number of received messages or e-mails is not displayed.

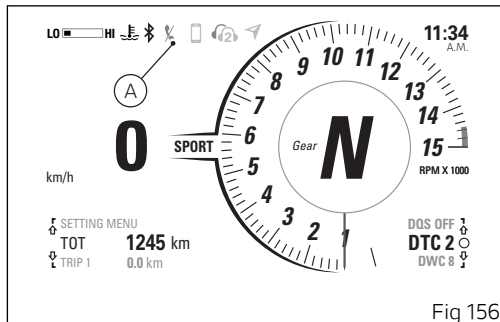

Fig 156

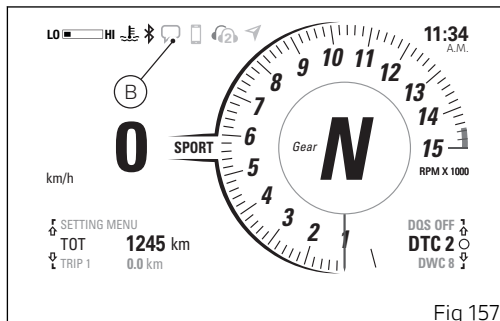

Fig 157

Heated handgrips

This function allows enabling and adjusting the heated handgrips, if any.

The heated handgrip status is indicated by the relevant symbol.

To enable and set the level of the heated handgrips, press button (10) (see chapter "Function buttons").

Every time the button is pressed, the level goes from OFF to LOW, MED and HIGH up to "OFF".

For each level, the heated handgrip symbol becomes of a specific colour:

- OFF = black in DAY mode, white in NIGHT mode
- LOW = green
- MED = amber yellow
- HIGH = red

If the level is set to OFF, after a few seconds the heated handgrip symbols goes off and will come back on upon next time button (10) is pressed.

If a level other than OFF is set, the handgrips are actually heated only with engine on.

Note

In case of battery disconnection, the level is set to OFF.

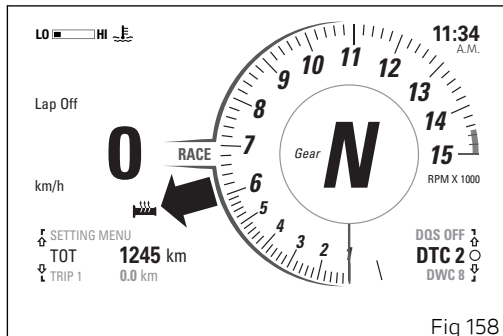

Note

If the handgrips are activated and the engine is stopped, the handgrips are disabled and the relevant icon colour will change, despite the indication remaining active. Heating will automatically be reactivated when engine is started again.

 **Note**

Handgrip heating requires a high current draw which, at low engine rpm, might result in the battery getting soon flat. If the battery is not fully charged (voltage below 13.2 V) handgrip heating is disabled to ensure engine start-up ability; it will automatically activate again when battery voltage is above the specified value.

Side stand status indication

If side stand is down/open, the instrument panel shows icon "SIDE STAND on a red background.

If instrument panel does not receive side stand status, "SIDE STAND" icon will flash to indicate an undefined status.

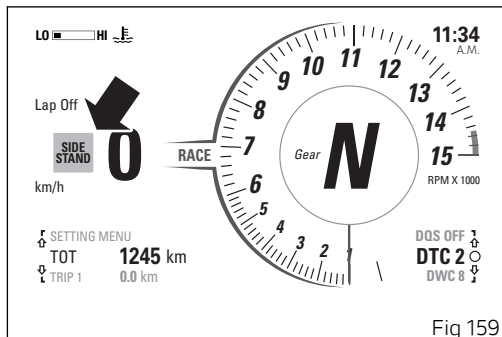

Service indication (SERVICE)

This indication shows the user that the motorcycle is due for service and must be taken to a Ducati Authorised Service Centre.

The service warning indication can be reset only by the Ducati Authorised Service Centre during servicing.

The types of maintenance operations are displayed in the area indicated in the figure and are as follows:

- OIL SERVICE zero
- OIL SERVICE countdown
- DESMO SERVICE countdown
- ANNUAL SERVICE countdown
- OIL SERVICE
- DESMO SERVICE
- ANNUAL SERVICE

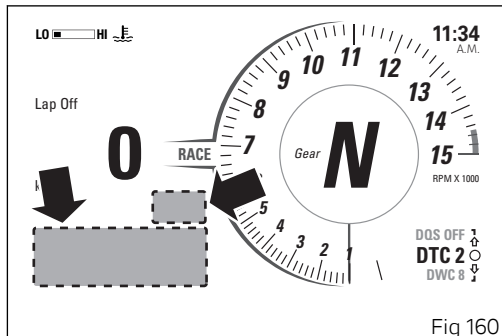

Fig 160

OIL SERVICE zero warning

The first service warning is the OIL SERVICE zero and is triggered as soon as the odometer reaches the first 1,000 km (600 mi). Warning is displayed until reset by the Ducati authorised service centre, during maintenance.

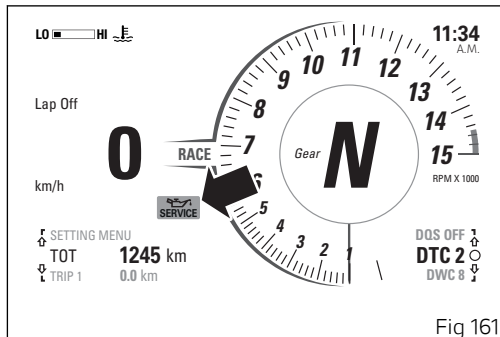

Fig 161

OIL SERVICE countdown, ANNUAL SERVICE countdown, DESMO SERVICE countdown

When the set service thresholds are close, the instrument panel activates the following yellow warnings for 5 seconds upon every Key-ON:

- The OIL SERVICE countdown warning (A) will activate when 1000 km (621 miles) are left before the OIL SERVICE is due.
- The ANNUAL SERVICE countdown warning (B) will activate 30 days before the ANNUAL SERVICE is due.
- The DESMO SERVICE countdown warning (C) will activate when 1000 km (621 miles) are left before the DESMO SERVICE is due.

It is possible to view the service deadlines through the "Service" function, within the SETTING MENU (see "SETTING MENU - Service").

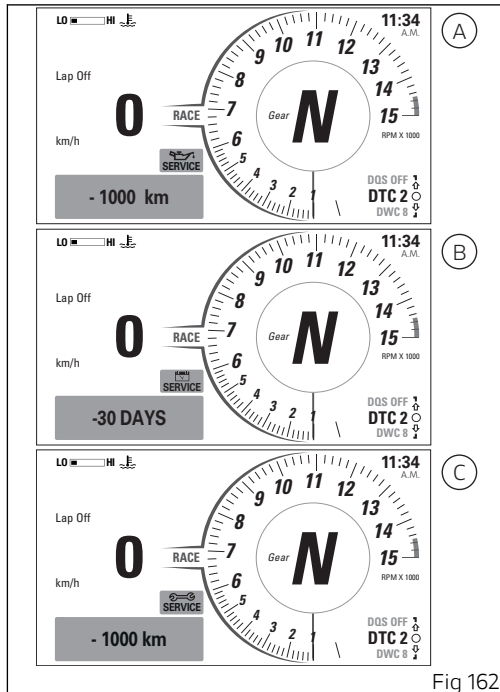

Fig 162

OIL SERVICE, ANNUAL SERVICE, DESMO SERVICE

When the service threshold is reached, the warning for the type of service required is triggered:

- OIL SERVICE (A);
- ANNUAL SERVICE (B);
- DESMO SERVICE (C).

Red service warning is displayed until reset by the Ducati authorised service centre, during maintenance.

It is possible to view the service deadlines through the "Service" function, within the SETTING MENU (see "SETTING MENU - Service").

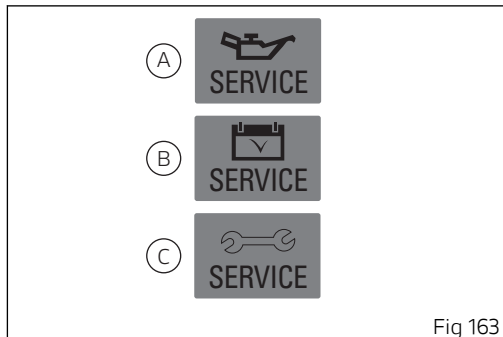

Error indication

The instrument panel manages error warnings in order to allow the rider to identify any abnormal motorcycle behaviour in real time.

Upon Key-On, in case of errors, the instrument panel turns on either the "MIL" light (A) (in case of errors directly connected to the engine control unit) or the "Generic Error" light (B) (in case of any other errors). During normal operation, when an error is triggered, the instrument panel turns on the "MIL" light (A) or the "Generic Error" light (B).



Attention

When one or more errors are displayed, always contact a Ducati Dealer or authorised Service Centre.

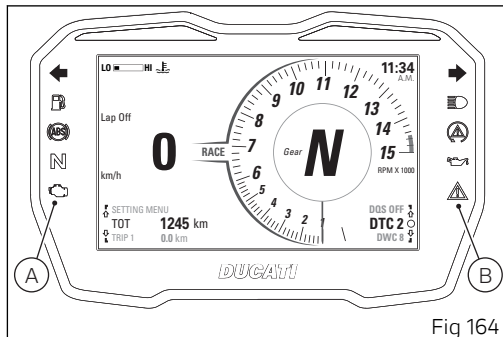

Fig 164

Warnings and alarms

The instrument panel manages a number of warnings and alarms, aimed at giving useful information to the rider during use.

Upon key-on, if there are any active warnings, the instrument panel will display the messages for all the present warnings or alarms: in a large size for the first 5 seconds and then in a smaller size.

When several warnings or alarms are active, they are displayed in a sequence, one every 3 seconds.

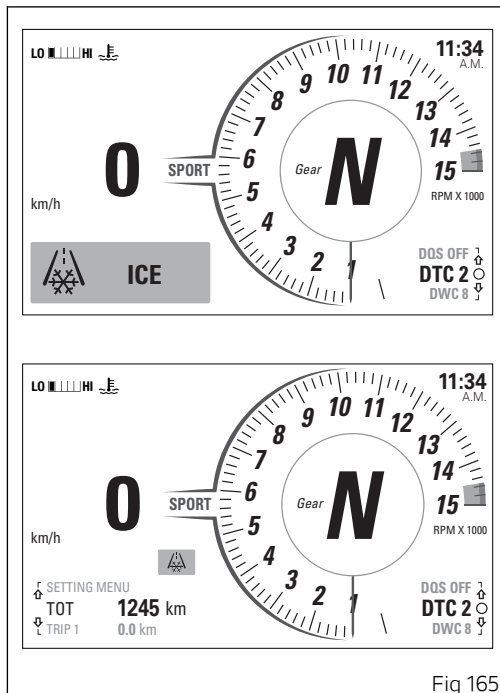

ICE

This warning means that there might be ice on the road, due to a low temperature.

Warning is activated when the instrument panel detects a temperature of 4°C (39°F) or lower than that. Warning will be disabled as soon as temperature rises up to 6°C (43°F).



Attention

This warning does not exclude the fact that there may be some ice on the road also if temperature is higher than 4 °C (39 °F). When the temperature is low, it is recommended to always ride with great care, especially on path sections not under the sun and/or bridges.

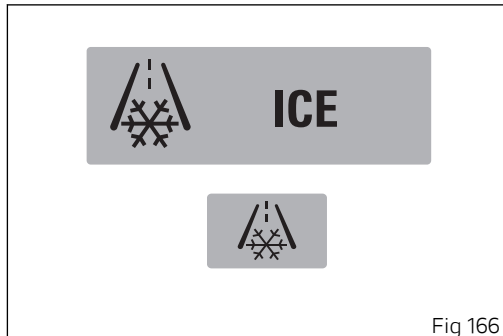

LOW BATTERY

This warning indicates that the vehicle battery voltage is low.

Warning is activated when battery voltage is lower than/equal to 11.0 Volt.

Note

In this case, Ducati recommends charging the battery in the shortest delay using the relevant equipment.

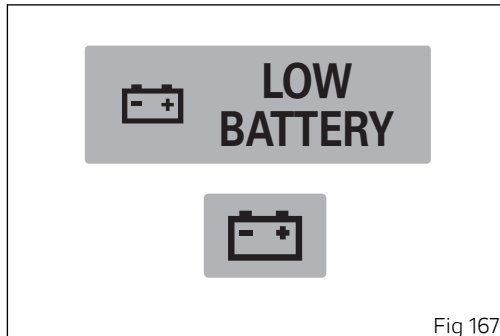

Fig 167

INSERT DATE

This warning indicates that the date must be entered using the "Date and Clock" function present within the SETTING MENU (see "SETTING MENU - Date and Clock").

DDA FULL

This warning indicates that DDA memory is full and no more data can be stored (see "SETTING MENU - DDA").

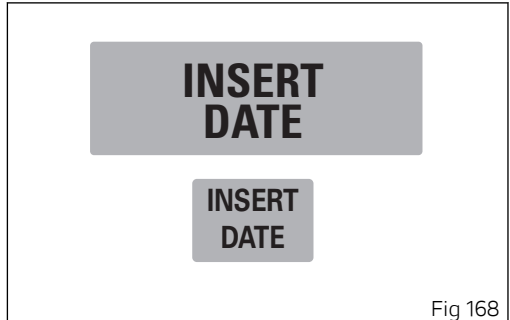

Fig 168

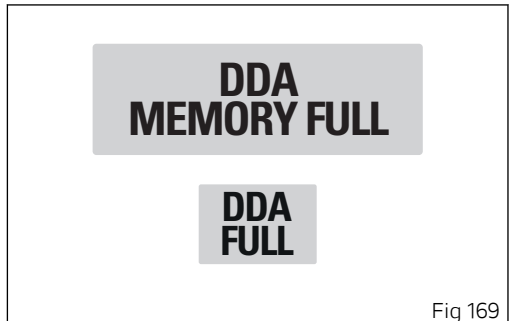

Fig 169

ABS FRONT ONLY

This warning indicates that it is necessary to ride carefully because the ABS setting in use only controls the front wheel braking.



Attention

In this case, Ducati recommends paying particular attention to the riding style and the braking mode.

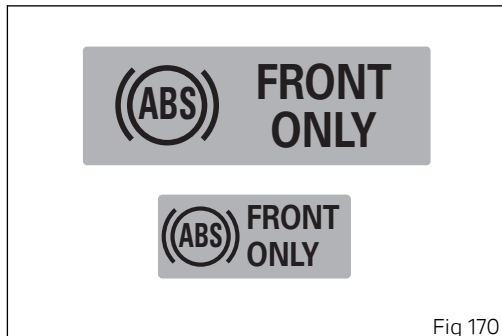

Main use and maintenance operations

Removing the fairing

Some parts of the motorcycle fairing have to be removed for certain maintenance or repair operations.



Attention

Failed or incorrect refitting of one of the removed components could cause its sudden detachment while riding resulting in loss of control of the motorcycle.



Attention

At every reassembly, to avoid damaging the painted areas, always place the nylon washers at the retaining screws.



Important

Have the fairing removal performed at a Ducati Dealer or Authorised Service Centre.

"Checking coolant level and topping up, if necessary"

Check the level according to the intervals indicated in the tables in "Scheduled maintenance chart".

Check coolant level in the expansion reservoir, on the right side of the vehicle, through the inner sight slot, gaining access from the front wheel housing.

Check that the level is between the MIN (1) and MAX (2) marks on the side of the expansion reservoir.

Top up if the level is below the MIN mark.

Attention

Place the motorcycle upright on a flat surface and make sure the engine is cold before proceeding.

Important

Have the top-up performed at a Ducati Dealer or Authorised Service Centre.

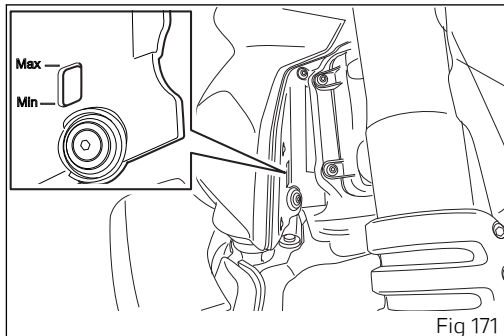

Checking brake and clutch fluid level

The levels should not fall below the MIN marks on the respective reservoirs.

If level drops below the limit, air might get into the circuit and affect the operation of the system involved.

Brake and clutch fluid must be topped up and changed at the intervals specified in the scheduled maintenance chart under "Scheduled maintenance"; please contact a Ducati Dealer or Authorised Service Centre.

Brake system

If you find exceeding clearance on brake lever or pedal and brake pads are still in good condition, contact your Ducati Dealer or authorised Service Centre to have the system inspected and any air drained out of the circuit.

Clutch system

If the control lever has exceeding clearance and the transmission snatches or jams as you try to engage a gear, it means that there might be air in the circuit. Contact your Ducati Dealer or authorised Service Centre to have the system inspected and air drained out.

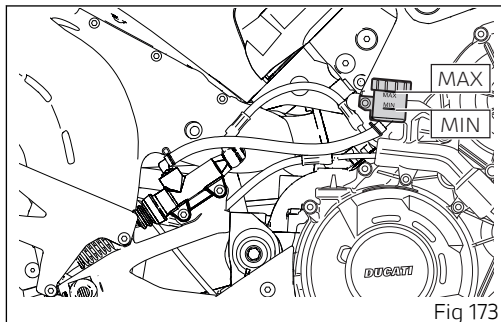
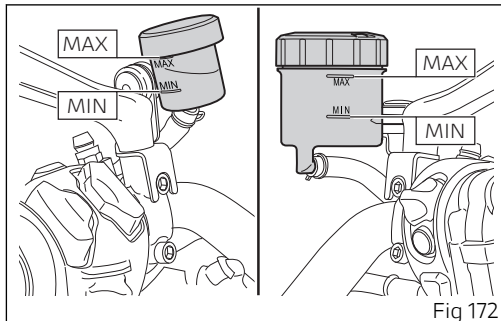



Attention

Brake and clutch fluid can damage paintwork and plastic parts, so avoid contact. Hydraulic fluid is corrosive; it may cause damage and lead to severe injuries. Never mix fluids of different qualities. Check seals for proper sealing.



Attention

Clutch fluid level will increase as clutch plate friction material wears down. Do not exceed the specified level (3 mm (0.12 in) above the minimum level).

Checking brake pads for wear

Check brake pads wear through the inspection hole in the callipers. Change both pads if friction material thickness of even just one pad is about 1 mm (0.04 in).

Attention

Friction material wear beyond this limit would lead to metal support contact with the brake disc thus compromising braking efficiency, disc integrity and rider safety.

Important

Have the brake pads replaced at a Ducati Dealer or authorised Service Centre.

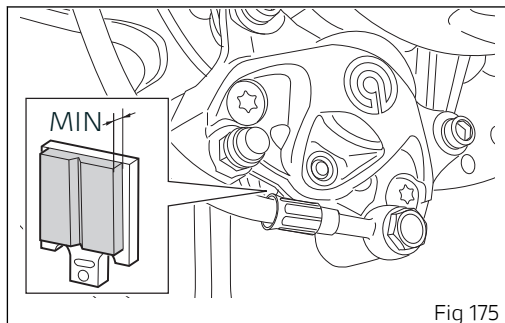
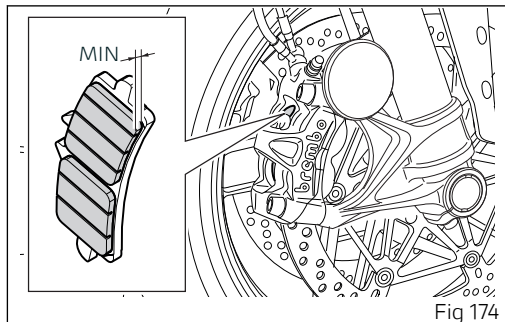

Charging the battery

Removing the battery



Attention

Have the battery removed at a Ducati Dealer or authorised Service Centre.

Before charging the battery, it is best to remove it from the motorcycle

Loosen the four screws (1), collect the relevant washers and remove tank cover (2).

Loosen screw (3) and slide out cover (4) retaining the battery.

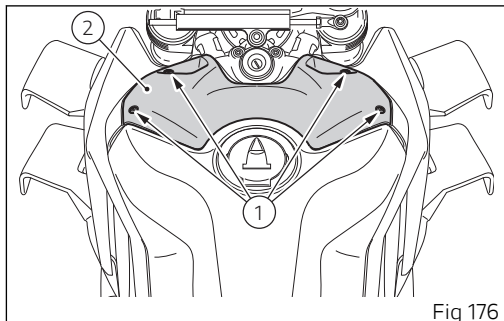

Fig 176

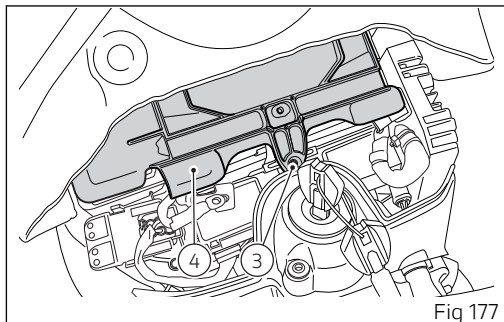
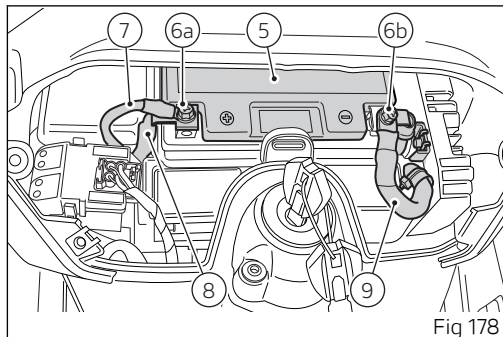

Fig 177

Slide out the battery (5) from its housing and, always starting from the negative terminal (-), loosen the screws (6a) and (6b). Remove the ABS positive cable (7) and positive cable (8) from the positive terminal and the two negative cables (9) from the negative terminal.



Refitting the battery

Lay down the ABS positive cable (7), onto positive cable (8) and start screw (6a) on these cables; Connect the two negative cables (9) to battery negative terminal, by starting the screw (6b). Tighten the screws (6) and apply grease onto the battery terminals to prevent oxidation. Reinstall the battery (5) in the support, positioning the cables as indicated. Position the cover (4) fastening the battery and tighten the screw (3).



Attention

Connect the ABS negative cable (9) aiming it towards the key switch as shown in the figure.

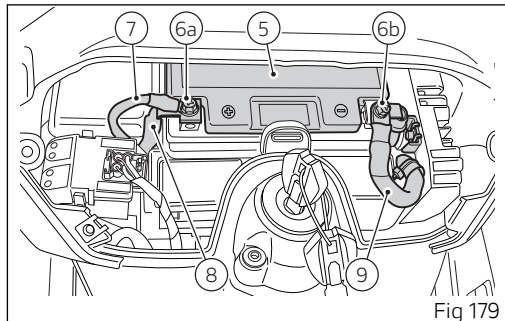

Fig 179

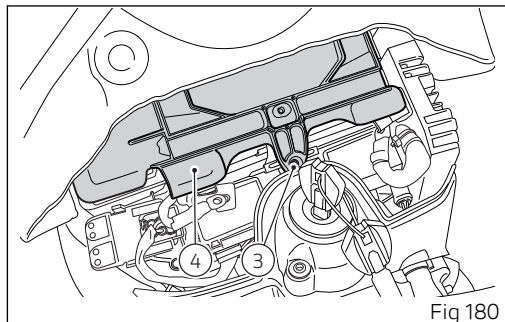

Fig 180

Once the tank cover (2) is positioned, tighten the four screws (1), complete with the relevant lower washers.

Charge the battery in a ventilated room. Connect the battery charger leads to the battery terminals: the red one to the positive terminal (+), the black one to the negative terminal (-). Ducati disclaims any liability deriving from the use of non-original Ducati chargers or maintainers.

It is recommended to use the Ducati dedicated battery charge maintainer (Battery Maintenance Kit part no. 69928471A (Europe), part no. 69928471AW (Japan), 69928471AX (Australia), 69928471AY (UK), 69928471AZ (USA), available from our sales network), and to operate as described in the subsection "Maintaining the battery charge".

⚠ Attention
Keep the battery out of the reach of children.

⚠ Attention
The battery produces explosive gases: keep it away from sparks, flames, cigarettes and heat sources.

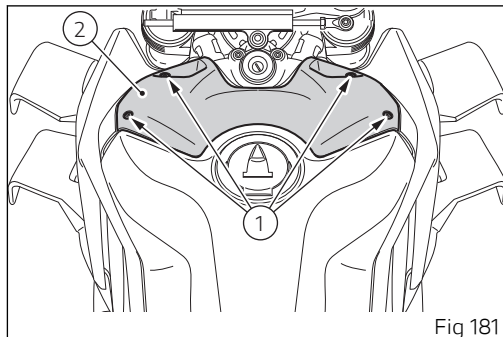

Fig 181

⚠ Attention
Prepare the battery charger for the necessary operation based on the indications provided in the owner's manual.

⚠ Important
Make sure the charger is OFF when you connect the battery to it, or you might get sparks at the battery terminals that could ignite the gases inside the cells. Always connect the red positive (+) terminal first.



Attention

NEVER connect the battery in parallel with that of other vehicles, as this may cause a short circuit or overheating of the battery.

Checking drive chain tension

Important

Have chain tension adjusted by a Ducati Dealer or authorised Service Centre.

Make the rear wheel turn until you find the position where chain is tightest. Set the motorcycle on the side stand. With just a finger, push down the chain at the point of measurement and release.

Measure the distance (A) between the centre of the chain pins and the plastic section of the chain sliding shoe. It must be:

A = 22÷24 mm (0.87÷0.94 in)

A = 22÷24 (0.71÷0.79 in) (TWN version)

Important

This only applies to the motorcycle STANDARD settings, available upon delivery.

Important

Improper chain tension will lead to early wear of transmission parts.

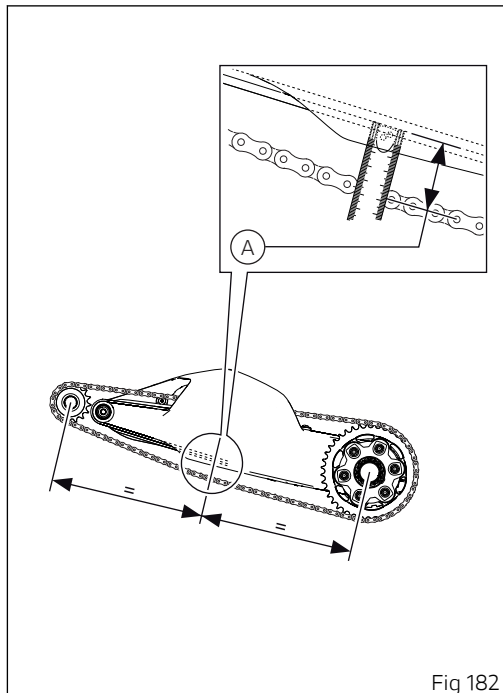

Fig 182



Important

To ensure the best performance and long life of the chain, please follow the information related to chain cleaning, lubrication, inspection and tensioning.

Lubricating the drive chain

Important

Have drive chain cleaned by a Ducati Dealer or authorised Service Centre.

Attention

Carry out these inspection operations with the engine off, the vehicle at a standstill, on a flat ground and on the stand.

Cleaning

Before proceeding with the chain lubrication it is important to correctly wash and clean it.

The chain cleaning is extremely important for its duration. In fact, it is necessary to remove any mud, soil, sand or dirt from the chain first using a soft damp cloth (1) to soften the most resistant dirt and then with a jet of water and then dry it immediately using compressed air at a distance of at least 30 cm (11.81 in).

Checking the chain

The chain fitted on your motorcycle has O-rings that keep dirt out of and lubricant inside the sliding parts. Check the chain for wear by checking the links at the points indicated (2).

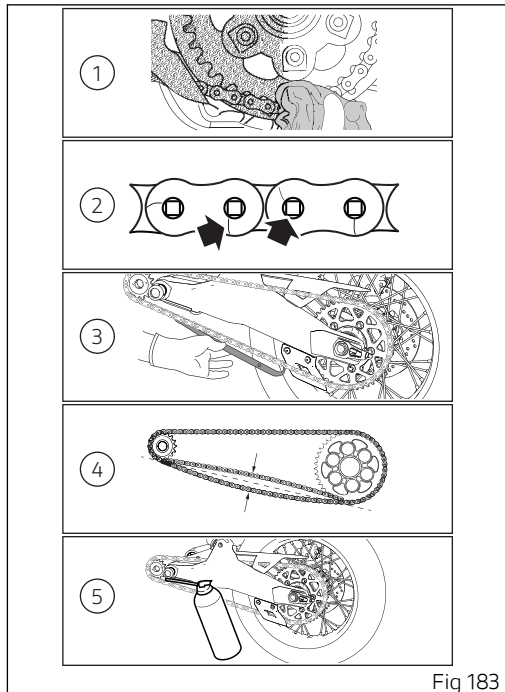

Fig 183



Attention

Avoid the use of steam, fuel, solvents, hard brushes or other methods that could damage the O-rings; also avoid direct contact with the battery acid as it could cause mini cracks in the links as shown in the figure.



Attention

In particular, in case of Off-Road use of the bike, it is possible that excessive wear of the links occurs due to the contact with the chain sliding shoe; friction could in fact cause the chain to overheat, altering the heat treatment of the links and making them particularly fragile.

Checking the sliding shoe

Check the wear of the sliding shoe (3) and, if necessary, contact a Ducati Dealer or Authorised Service Centre.

Checking the tension

Check the chain tension (4) as indicated in the subsection "Checking the drive chain tension". Have the chain tension adjusted by a Ducati Dealer or authorised Service Centre.

Lubrication

Important

Have drive chain cleaned by a Ducati Dealer or authorised Service Centre.

Attention

Use SHELL Advance Chain to lubricate the chain; the use of non-specific lubricants could damage the O-rings and therefore the entire drive system.

It is recommendable to lubricate the chain without waiting for it to cool down after using the motorcycle, so that the new lubricant can penetrate better between the inner and outer links and be more effective in its protective action.

Place the bike on the rear paddock stand. Make the rear wheel turns fast in the opposite direction to the direction of travel.

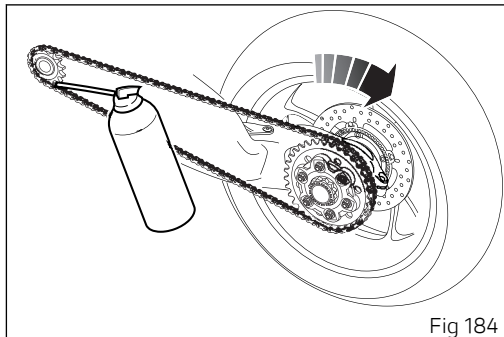
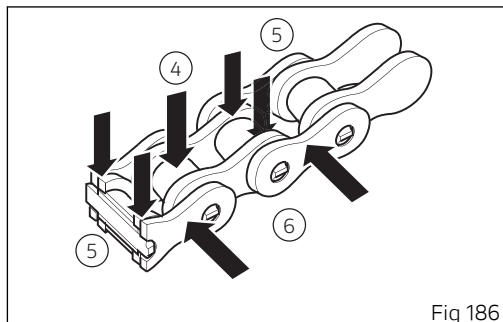
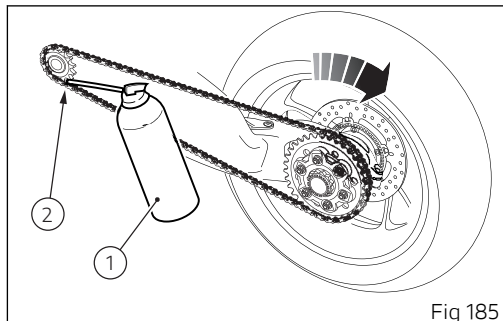

Fig 184

Apply the lubricant jet (1) inside the chain between the inner and outer links, in point (2) immediately before the engagement point on the sprocket.

Due to the centrifugal force, the lubricant, made fluid by the solvents contained in the spray, will expand in the working area between the pin and the bush, ensuring perfect lubrication.

Repeat the operation by aiming the lubricant jet to the central part (5) of the chain so as to lubricate the rollers (4), and to the outer plates (6) as shown in the figure.



After lubrication, wait 10-15 minutes to allow the lubricant to act on the internal and external surfaces of the chain and then remove the excess lubricant with a clean cloth.

⚠ Important

Do not use the motorcycle immediately after lubricating the chain as the lubricant, still fluid, would be centrifuged outwards causing possible soiling of the rear tyre or the rider's footpeg.

⚠ Important

Check the chain often, taking care to lubricate it, as also indicated in the table below: at least every 1000 km (621 mi) or more frequently (about every 400 km (248 mi)) when using the bike with high outside temperatures (40°C) or after long travels on the highway at high speed.

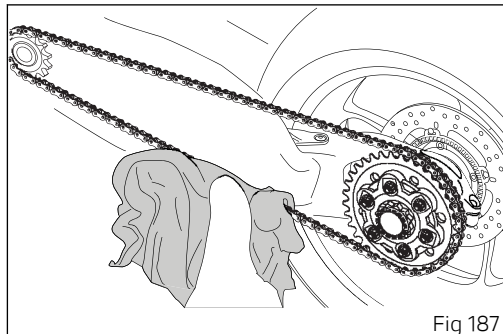

Fig 187

Replacing the high and low beam bulbs

The whole front LED headlight assembly is maintenance-free. Figure shows the locations of the high beam (HI), low beam (LO) and parking lights (1). Have the lights replaced at a Ducati Dealer or authorised Service Centre.

Turn indicators

The turn indicators are LED-type and do not require any maintenance.

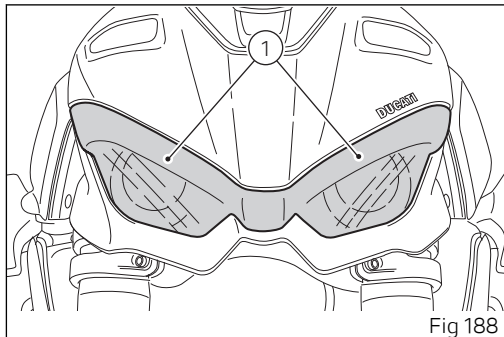

Fig 188

Aligning the headlight



Note

This is the procedure specified by Italian regulations for checking the maximum height of the light beam. Please adapt said procedure to the provisions in force in your own country.

Check correct headlight aiming. Position the motorcycle 10 m (32.8 ft) from a wall or a screen, the motorcycle must be perfectly upright with the Tyres inflated to the correct pressure and with a rider seated, perfectly perpendicular to the longitudinal axis. On the wall or surface, draw a horizontal line at the same height from the ground as the centre of the headlight and a vertical line aligned with the longitudinal axis of the motorcycle. If possible, perform this check in dim light. Switch on the low beam and adjust right and left beams by alternatively covering the right one while adjusting the left one and vice versa: the height of the upper limit between the dark area and the lit area must not be more than $\frac{9}{10}$ of the height from the ground of the headlight centre.

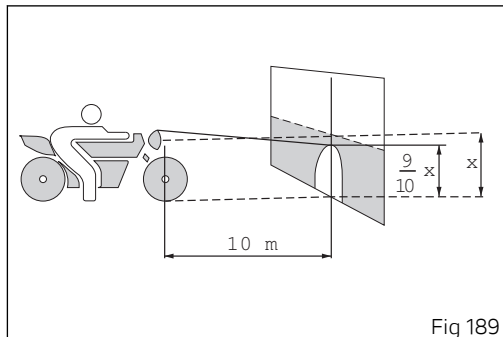

Fig 189

To align the headlight beam, turn the screws (1) and (2) located at the front of the vehicle, on both sides.

Screw (1), positioned on the left side, acts on the left high and low beams:

- turn clockwise to lower the light beam;
- turn counter clockwise to raise the light beam.

Screw (2), positioned on the right side, acts on the right high and low beams:

- turn clockwise to lower the light beam;
- turn counter clockwise to raise the light beam.

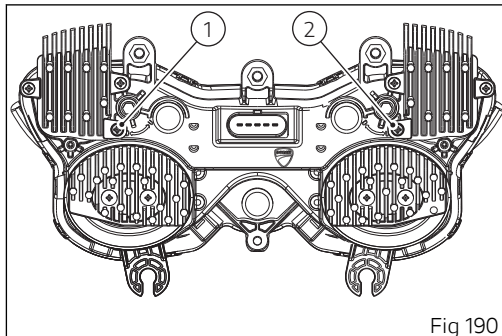

Fig 190

Adjusting the rear-view mirrors

Manually adjust rear-view mirror (A) to required position.



Attention

This type of adjustment must be performed with attention to avoid forcing the rear-view mirror position and damaging it.

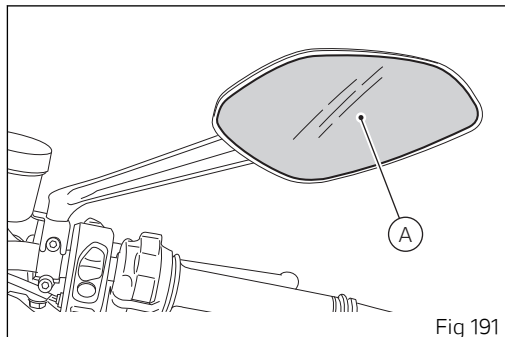

Fig 191

Tubeless tyres

For information on tyre type and inflation pressure, see the "Tyres" sub-section in the "Technical specifications" section. Pressure

As tyre pressure is affected by ambient temperature and altitude variations, you are advised to check and adjust it whenever you are riding in areas where ample variations in temperature or altitude occur.

Attention

Check and set tyre pressure when tyres are cold. To avoid front wheel rim distortion, when riding on bumpy roads, increase tyre pressure by 0.2 ÷ 0.3 bar (2.90÷4.35 psi).

Tyre repair or change (Tubeless tyres)

In the event of a tiny puncture, tubeless tyres will take a long time to deflate, as they tend to keep air inside. If you find low pressure on one tyre, check the tyre for punctures.

Attention

Punctured tyres must be replaced. Replace tyres with recommended standard tyres only. Be sure to tighten the valve caps securely to avoid leaks when riding. Never use tube type tyres. Failure to heed this warning may lead to sudden tyre bursting and to serious danger to rider.

After replacing a tyre, the wheel must be balanced.

Attention

Do not remove or shift the wheel balancing weights.

Note

Have the tyres replaced at a Ducati Dealer or authorised Service Centre. Correct removal and installation of the wheels is essential. Some parts of the ABS (such as sensors and phonic wheels) are mounted to the wheels and require specific adjustment.

Minimum tread depth

Measure tread depth (S) at the point where tread is most worn down: it should not be less than 2 mm (0.08 in), and in any case not less than the legal limit.



Important

Visually inspect the tyres at regular intervals for detecting cracks and cuts, especially on the side walls, bulges or large spots that are indicative of internal damage. Replace them if badly damaged. Remove any stones or other foreign bodies caught in the tread.

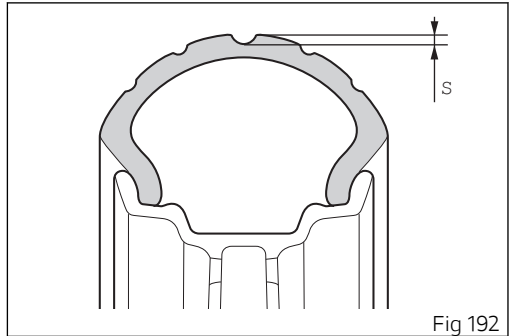

Check engine oil level

Engine oil level can be checked through the sight glass (1) located on the left side of the engine block. Oil level should be between the marks on the sight glass. If the level is low, top up with engine oil.

Ducati prescribes the only use of SAE 15W -50/JASO MA2 oil and recommends the use of Shell Advance 4T Ultra 15W -50 oil (JASO: MA2 and API: SN)

Remove the oil filler cap (2) located on the right side of the vehicle and top up until the oil reaches the required level. Refit the filler plug (2).

Important

UK VERSION: Ducati recommends you use Shell Advance DUCATI 15W-50 Fully Synthetic Oil.

Important

Engine oil and oil filters must be changed by a Ducati Dealer or Authorised Service Centre at the intervals specified in the scheduled maintenance chart contained in this manual, sub-section "Scheduled maintenance chart".

To check the oil level correctly, carefully follow the instructions below.

1) The level should be checked at warm engine, about 15 minutes after the engine has been stopped.

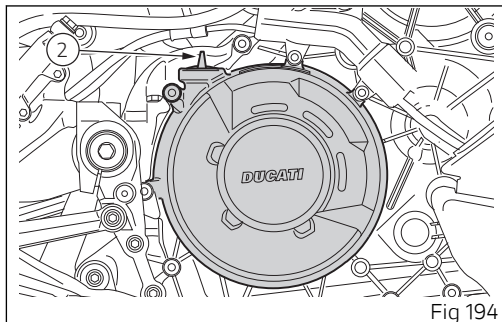
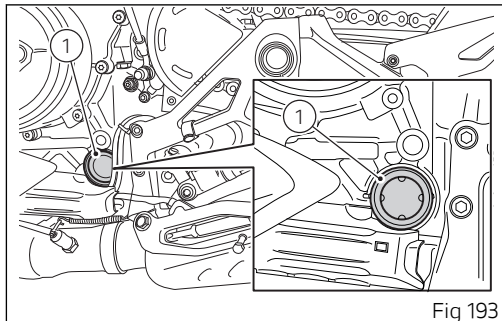

- 2) Position the bike with both wheels on a flat ground and in straight position.
- 3) Then, check the engine oil through the sight glass.
- 4) If the oil level is below the middle line between the MIN and MAX marks, add oil until reaching the maximum level indication.
- (American standard) and JASO (Japanese standard) standards specify oil characteristics.



Attention

Never exceed the MAX mark.

Recommendations concerning oil

It is recommended to use oil complying with the following specifications:

- viscosity grade SAE 15W-50;
- standard API: SN;
- standard JASO: MA2.



Attention

UK VERSION: It is recommended to use oil complying with the following specifications:

- viscosity grade SAE 15W-50.

SAE 15W-50 is an alphanumerical code identifying oil class based on viscosity: two figures with a W ("winter") in-between; the first figure indicates oil viscosity at low temperature; the second figure indicates its viscosity at high temperature. API

Cleaning the motorcycle

To preserve the finish of metal parts and paintwork, wash and clean your motorcycle at regular intervals, anyway according to road conditions. Use specific products only. Prefer biodegradable products. Avoid aggressive detergents or solvents.

Use only water and neutral soap to clean the seat. Periodically clean by hand all aluminium components. Use special detergents, suitable for aluminium parts. Do NOT use abrasive detergents or caustic soda.

However, the warranty does not apply to motorcycles whenever poor maintenance status is ascertained.

Rinse with warm water and dry all surfaces with chamois leather.

Carefully clean the phonic wheels of the ABS in order to ensure system efficiency. Do not use aggressive products in order to avoid damaging the phonic wheels and the sensors.

Pay special attention when cleaning the wheel rims since they have parts in machined aluminium; clean and dry them every time you use the vehicle.



Important

Do not wash your motorcycle right after use. When the motorcycle is still hot, water drops will evaporate faster and spot hot surfaces.

Never clean the motorcycle using hot or high-pressure water jets.

Cleaning the motorcycle with a high pressure water jet may lead to seizure or serious faults in forks, wheel hubs, electric system, headlight (fogging), fork seals, air inlets or exhaust silencers, with consequent loss of compliance with the safety requirements.

Clean off stubborn dirt or exceeding grease from engine parts using a degreasing agent. Be sure to avoid contact with drive parts (chain, sprockets, etc.).



Note

Do not use sponges with abrasive parts or steel wool: only use soft cloths.



Attention

Braking performance may be impaired immediately after washing the motorcycle. Never grease or lubricate the brake discs to avoid losing braking power. Clean the discs with an oil-free solvent.



Attention

The headlight might fog up due to washing, rain or moisture. Switch headlight on for a short time to help and dry up any condensate.



Attention

Avoid direct contact between instrument panel lens and oils/fuels that may stain or damage it thereby impairing information readability. To clean such parts, do not use alcohol-based detergents, containing solvent or abrasive agents; do not use sponges or cloths featuring hard or rough areas since they might scratch the surface.



Note

Clean instrument panel lens using soft cloths with water and mild soap or detergents specific for cleaning clear plastic parts.



Note

To clean the instrument panel do not use alcohol or its by-products.



Important

To clean and lubricate the drive chain, refer to the paragraph "Lubricating the drive chain".

Cleaning and replacing the spark plugs

Spark plugs are essential to smooth engine running and should be checked at regular intervals. Have the spark plug replaced by a Ducati Dealer or an authorised Service Centre.

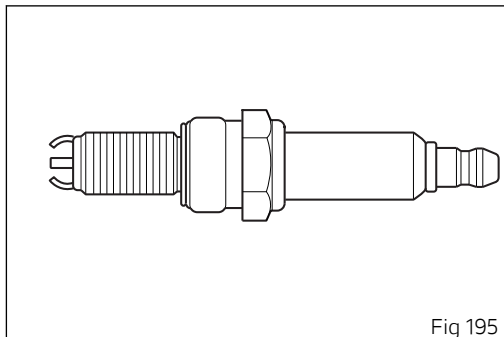

Storing the motorcycle

If the motorcycle is to be left unriden over long periods, it is advisable to carry out the following operations before storing it away:

- clean the motorcycle;
- empty the fuel tank;
- place the motorcycle on a service stand;
- disconnect, remove the battery and periodically charge it using the battery charge maintainer (see "Charging the battery");
- protect the motorcycle with a suitable canvas. This will protect paintwork and let condensate breathe out. The canvas is available from Ducati Performance.

Important notes

Laws in some countries set certain noise and pollution standards.

Periodically carry out the required checks and renew parts as necessary, using Ducati original spare parts, in compliance with the regulations in the country concerned.

Various electronic components of your vehicle have data memories that temporarily or permanently

store technical information on the status, events and faults of the vehicle.

In general, this information documents the status of a component, module, system or environment.

- Operating status of system components (e.g. emission control system).
- Status messages of the vehicle and its components (e.g. wheel rotation speed, engine rpm, engaged gear, etc.)
- Malfunctions and faults of important system components (e.g. lights, brakes, etc.)
- Vehicle response in particular riding situations (e.g. traction control system, etc.)
- Environmental conditions (e.g. temperature, etc.)

These data are always of a technical nature and are used to detect and correct faults and optimise vehicle functions.

During service operations such as repairs, maintenance activities, operations under warranty, and quality assurance, service network personnel (including manufacturers) can read this technical information from the event and fault data memory using special diagnostic tools. Once the fault has been eliminated, it is possible to progressively

delete or overwrite the information in the fault memory.

Vehicle data are collected as a result of a service requested by the Customer or provided under a contract (on the vehicle).

Within the scope of these services, personal data are processed in compliance with current legislation on data protection, based on a legitimate interest of Ducati to ensure increasingly efficient assistance, and finally to comply with legal obligations (e.g. information obligations on repairs and maintenance). If necessary, personal data are read and used in combination with the vehicle identification number.

Our control units do not collect geolocation data.

Vehicle transport

Before transporting the motorcycle using another vehicle, follow the safety instructions below.

- 1) Remove all loose objects and accessories from the vehicle;
- 2) Align the front wheel straight in the riding direction and lock it properly to prevent any movement;
- 3) Engage the first gear;
- 4) Use the anchoring straps and apply them to strong components (e.g. frame) and NOT to the handlebar (or handlebars, where present) or to components that could break (e.g. handgrips, rear-view mirrors, etc.);
- 5) The straps or ropes must NOT rub against any painted motorcycle components;
- 6) The suspensions, if possible, must be in a partially compressed position so as to allow less movement of the vehicle with respect to the road surface during transport.

Do NOT attach the ropes to the handlebar.

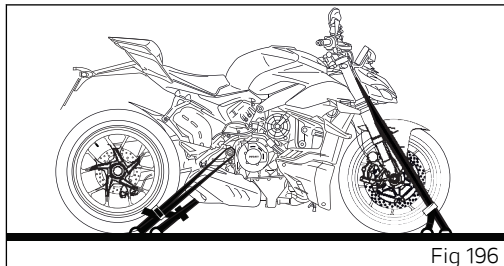

Fig 196

Scheduled maintenance chart



Scheduled maintenance chart: operations to be carried out by the dealer



This scheduled maintenance chart is designed for a road use of the Streetfighter V4. If it is used on the track, even if not during sport competitions, all parts of the motorcycle are more stressed so the routine maintenance operations must be carried out more frequently than indicated.





Please contact a Ducati Dealer or authorised Service Centre where you can receive customised service advice according to the sport use you make of your Streetfighter V4.



Important

Using the motorcycle under extreme conditions, such as very damp and muddy roads or dusty and dry environment, could cause above-average wear of components like the drive system, the brakes or the air filter. If the air filter is dirty, the engine could get damaged. Therefore, this might translate in required service or replacement of the wear parts earlier than specified in the scheduled maintenance chart.

	Mileage Service* 		
	DESMO Mileage Service* 		
	OIL Mileage Service* 		
	1000 Mileage Service*		
Reading of the error memory with DDS 3.0 and check of technical updates and recall campaigns on DCS	•	•	12
Change engine oil and filter	•	•	12

	Mileage Service* 		
	DESMO Mileage Service* 		
	OIL Mileage Service* 		
	1000 Mileage Service*		
Check and clean air filter		•	12
Change air filter		•	
Check and/or adjust valve clearance		•	
Check secondary air reeds		•	
Change spark plugs		•	
Change coolant		•	48
Change front fork fluid			36
Visually check the front fork and rear shock absorber seals	•	•	12
Check brake and clutch fluid level	•	•	12
Change brake and clutch fluid			24
Check front and rear brake disk and pad wear		•	12
Check the proper tightening of the front and rear brake calliper bolts and the front brake disc bolts		•	12
Check rear brake disk screw tightening (by removing the rear wheel shaft in case of brake disk retaining screws requiring the use of hexagon wrench)		•	

				Mileage Service* 
				DESMO Mileage Service* 
				OIL Mileage Service* 
				1000 Mileage Service*
Check front and rear wheel nuts and rear sprocket nut tightening		•		12
Check the tightening of frame fasteners to engine, swinging arm and rear shock absorber		•		12
Check the tightening fastening the RH tripod to the rear bank			•	
Check wheel hub bearings		•		12
Check the cush drive damper on rear sprocket and lubricate the rear wheel shaft			•	
Check wear of chain, chain sliders, front and rear sprockets. Check chain elongation, tension and lubrication. Detected elongation value:_____ (mm)	•	•		12
 Note We recommend replacing the final drive chain kit within 20,000 km/12,000 mi.				
Check play of steering tube bearings		•		12
Check the freedom of movement and tightening of the side stand		•	•	12
Check that all gaiters and flexible hoses in view (e.g. fuel, brake and clutch hoses, cooling system, bleeding, drainage, etc.) are not cracked, are properly sealing and positioned		•	•	12
Check free play of rear brake lever and lubricate the levers at the handlebar and pedal controls		•	•	12

	Mileage Service* 		
	DESMO Mileage Service* 		
	OIL Mileage Service* 		
	1000 Mileage Service*		
Check tyre pressure and wear	.	.	12
Check the operation of all electric safety devices (clutch and side stand sensor, front and rear brake switches, engine kill switch, gear/neutral sensor)	.	.	12
Check lighting devices, turn indicators, horn and controls operation	.	.	12
Exhaust valve Bowden cable adjustment with DDS 3.0	.	.	12
Final test and road test of the motorcycle, testing safety devices (e.g. ABS and DTC), electric fans and idling	.	.	12
Visually check the coolant level and sealing of the circuit	.	.	12
Soft cleaning of the vehicle, record the service coupon and warning light turning off on the instrument panel using the DDS 3.0	.	.	12

* The 1000 Mileage Service must be carried out after the first 1,000 km/600 mi.

* The OIL Mileage Service  must be carried out every 12,000 km/7,500 mi.

* The DESMO Mileage Service  must be carried out every 24,000 km/15,000 mi.

* The Time Service  must be carried out every 12 months.

Scheduled maintenance chart: operations to be carried out by the customer



Important

Using the motorcycle under extreme conditions, such as very damp and muddy roads or dusty and dry environment, could cause above-average wear of components like the drive system, the brakes or the air filter. If the air filter is dirty, the engine could get damaged. Therefore, this might translate in required service or replacement of the wear parts earlier than specified in the scheduled maintenance chart.

List of operations and type of intervention [set mileage (km/mi) or time interval *]	Km. x1,000	1
	mi. x1,000	0.6
	Months	6
Check engine oil level		•
Check brake and clutch fluid level		•
Check tyre pressure and wear		•
Check the drive chain tension and lubrication		•
Check brake pads. If necessary, contact your dealer to replace components		•

* Service operation to be carried out in accordance with the specified distance or time intervals (km, miles or months), whichever occurs first.

Technical data

Weights

Overall Weight (in running order with 90% of fuel - 44/2014/EU Annex XI)	201 kg (443.13 lb).
Overall weight (without fluids and battery)	180 kg (396.83 lb).
Maximum allowed weight (carrying full load)	425 kg (936.96 lb).



Attention

Failure to observe weight limits could result in poor handling and impair the performance of your motorcycle, and you may lose control of the motorcycle.

Overall dimensions

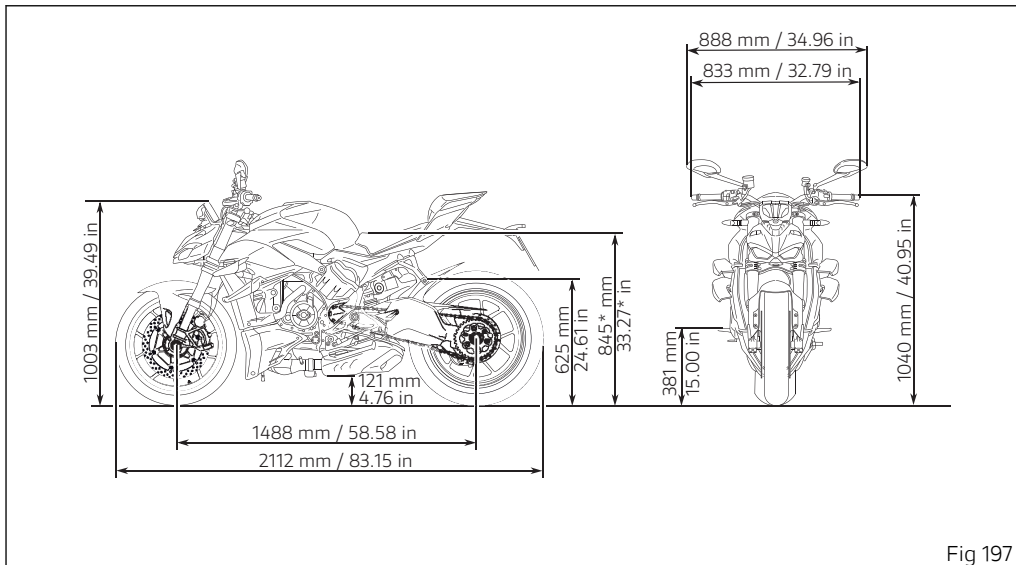

Fig 197

* Lowered seat: 826 mm (32.52 in).

Top-ups

TOP-UPS	TYPE	
Fuel tank, including a reserve of 4.5 litres (0.99 UK gal)	Ducati recommends SHELL V-Power unleaded premium fuel with a minimum of octane rating of RON 95	16 litres (3.52 UK gal)
Oil sump and filter	Ducati prescribes the only use of SAE 15W-50/JASO MA2 oil and recommends the use of Shell Advance 4T Ultra 15W-50 oil (JASO: MA2 and API: SN). SHELL Advance DUCATI 15W-50 Fully Synthetic Oil (UK VERSION)	3.4 litres (0.75 UK gal)
Front/rear brake and clutch circuits	DOT 4	-
Protectant for electric contacts	Protective spray for electric systems	-
Front fork	SHELL Donax TA	-
Cooling circuit	ENI Agip Permanent Spezial antifreeze (do not dilute, use pure)	2.5 litres (0.55 UK gal)



Important

Do not use any additives in fuel or lubricants. Using them could result in severe damage of the engine and motorcycle components.



Attention

The motorcycle is only compatible with fuel having a maximum content of ethanol of 10% (E10). Using fuel with ethanol content over 10% is forbidden. Using it could result in severe damage of the engine and motorcycle components. Using fuel with ethanol content over 10% will make the warranty null and void.



Important

These references identify the fuel recommended for this vehicle, as specified by the European Regulation EN228.



Engine

Desmosedici Stradale: V4 90°, counter-rotating crankshaft, Desmodromic timing system, 4 valves per cylinder, liquid cooling.

Bore: 81 mm (3.19 in)

Stroke: 53.5 mm (2.11 in)

Total displacement: 1103 cu. cm (67.3 cu in).

Compression ratio: 14.0 ± 0.5:1

Maximum power at crankshaft (EU) Regulation no. 134/2014, Annex X, kW/HP:

153.2 kW / 208 HP at 12750 rpm

Maximum power at crankshaft (EU) Regulation no. 134/2014, Annex X, kW/HP

(for Belgium/France version only):

84 kW / 114.2 HP at 7750 rpm

Maximum torque at crankshaft (EU) Regulation no. 134/2014 Annex X:

112 Nm - 12.5 kgm at 8,750 rpm

Maximum torque at crankshaft (EU) Regulation no. 134/2014 Annex X

(for Belgium/France version only):

105.4 Nm - 12.5 kgm at 7500 rpm

Max. torque at crankshaft Regulation (EU) no. 134/2014 Annex X (Russia version only):
122.5 Nm / 12.5 kgm at 11500 rpm

Maximum rpm: 14,500 rpm / 15,000 rpm (6th gear).



Note

The engine control unit disables the 2 rear bank cylinders when engine is idling and the throttle twistgrip is fully released. This disabling is only implemented when some conditions are verified and namely depending on the engine temperature, gear engaged and clutch lever position (that must be completely pulled unless gear is in Neutral). This strategy ensures advantages in terms of fuel economy and rider's comfort because of less heat.



Important

Do not exceed the specified rpm limits in any running conditions.



Note

The indicated power/torque values have been measured with a static test bench according to type-approval standards and match with the data detected during type-approval process; they are indicated in the vehicle registration document.

Lubrication

Trochoid oil delivery pump with integrated by-pass valve and two scavenge pumps.

Oil cooler.

Timing system

Desmodromic, 4 valves per cylinder

Desmodromic timing system

- 1) Opening rocker arm (or upper);
- 2) Opening rocker shim;
- 3) Closing (or lower) rocker shim;
- 4) Return spring for lower rocker;
- 5) Closing (or lower) rocker;
- 6) Camshaft;
- 7) Valve.

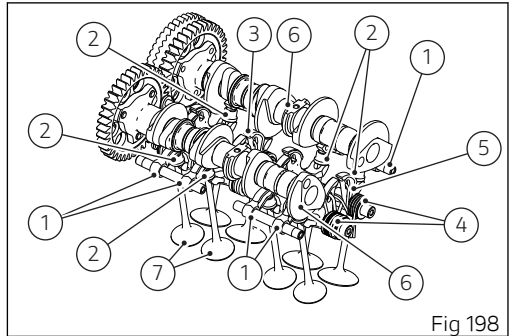

Fig 198

Performance

Maximum speed in any gear should be reached only after a correct running-in period with the motorcycle properly serviced at the recommended intervals.

Important

Failure to follow these instructions releases Ducati Motor Holding S.p.A. from any liability whatsoever for any engine damage or shorter engine life.

Spark plugs

Make: NGK.

Type: LMDR10A-JS.

Fuel system

Inductive discharge indirect electronic injection, intake system with variable length ducts.

Throttle body: Full Ride-by-Wire elliptical, aerodynamic throttle.

Corresponding diameter: 52 mm (2.05 in)

Injectors per cylinder: 2

Fuel supply: 95-98 RON.

Attention

The motorcycle is only compatible with fuel having a maximum content of ethanol of 10% (E10). Using fuel with ethanol content over 10% is forbidden. Using it could result in severe damage of the engine and motorcycle components. Using fuel with ethanol content over 10% will make the warranty null and void.

Brakes

Separate-action anti-lock braking system operated by hall-type sensors mounted to each wheel with phonic wheel detection: ABS can be disabled.

FRONT

Brake discs

Semi-floating drilled twin-disc.

Braking material: stainless steel.

Carrier material: aluminium and aluminium alloys.

Disc diameter: 330 mm (12.99 in).

Brake disc thickness: 5 mm (0.2 in).

Brake disc thickness (maximum wear): 4.5 mm (0.18 in).

Disc braking surface: 264 sq. cm (40.92 in²).

Brake control

Hydraulically operated by a control lever on handlebar right-hand side.

Brake callipers

Brake calliper make: BREMBO.

Type: Stylema® monobloc M4.30 b, radial mount (ABS Cornering EVO)

Number of pistons per calliper: 4

Calliper cylinder diameter: 30 mm (1.18 in).

Friction material: BRM 10 A HH.

Brake master cylinder

Cylinder Ø: 16 mm (0.63 in).

Master cylinder type: PR16/21.

REAR

Brake disc

With fixed drilled stainless steel disc.

Disc diameter: 245 mm (9.6 in).

Brake disc thickness: 5 mm (0.2 in).

Brake disc thickness (maximum wear): 4.5 mm (0.18 in).

Disc braking surface: 219 sq. cm (33.95 ²)

Brake control

Hydraulically operated by a pedal on RH side.

Brake calliper

Brake calliper make: BREMBO

Number of pistons per calliper: 2.

Piston diameter: 34 mm (1.34 in).

Cornering ABS as standard.

Friction material: Ferodo Ferit I/D 450 FF.

Brake master cylinder

Master cylinder type: PS 13.

Brake calliper master cylinder piston diameter: 13 mm (0.51 in).



Attention

The brake fluid used in the brake system is corrosive.

In the event of accidental contact with eyes or skin, wash the affected area with abundant running water.

Transmission

Hydraulically-controlled slipper/self-servo wet multiplate clutch controlled by the adjustable lever on left-hand side of the handlebar.

Drive is transmitted from engine to gearbox primary shaft via spur gears.

Primary drive: 1.80:1

Primary drive: front / rear sprocket ratio: 30/54.

6-gear gearbox with Ducati Quick Shift (DQS) up/down EVO2, gear change pedal on left side of motorcycle.

Gearbox output sprocket/rear chain sprocket ratio:
15/42

Gearbox output sprocket/rear chain sprocket ratio
(TWN): 16/39

Total gear ratios:

1st 38/14

2nd 36/17

3rd 33/19

4th 32/21

5th 30/22

6th 30/24

Drive chain from gearbox to rear wheel.

Make: DID 525HV3 KAI.

Links: 116.

Make (TWN): DID 525HV3 KA ZJ.

Links: 112.

Important

The above gear ratios are the homologated ones and under no circumstances must they be modified.

However, if you wish to tune up your motorcycle for competitions or special tracks, Ducati Motor Holding S.p.A. will be pleased to provide information about

the special ratios available. Contact a Ducati Dealer or Authorised Service Centre.



Attention

If the rear sprocket needs replacing, contact a Ducati Dealer or authorised Service Centre. Incorrect replacement of this component could seriously compromise your safety and cause irreparable damage to the motorcycle.

Frame

"Front frame" in aluminium alloy with improved stiffness.

Aluminium alloy rear subframe.

Steering head angle: 24.5°

Steering angle: 28° LH side / 28° RH side

Trail: 100 mm (3.94 in).

Wheels

Front

Five-spoke, light-alloy rim.

Size: 3.50x17"

Rear

Five-spoke, light-alloy rim.

Size: 6.00x17"

Tyres

Tyre type

Front

Front Pirelli Diablo Rosso Corsa "tubeless" radial type 2.

Size: 120/70-ZR17.

Rear

Front Pirelli Diablo Rosso Corsa "tubeless" radial type 2.

Size: 200/60-ZR17.

Tyre pressure

Use	Front	Rear
On the road (rider only)	2.4 bar (34.81 psi)	2.5 bar (36.26 psi)
On the road (rider and passenger)	2.4 bar (34.81 psi)	2.7 bar (39.16 psi)
On track (rider only)	2.0 bar (29.01 psi)	2.2 bar (31.91 psi)



Attention

Check and set tyre pressure when tyres are cold. To avoid front wheel rim distortion, when riding on bumpy roads, increase tyre pressure by 0.2 ÷ 0.3 bar (2.90÷4.35 psi).

Suspensions

Front

Fully adjustable Showa BPF upside-down fork with 43 mm (1.69 in) chromed steel fork legs.

Wheel travel:

120 mm (4.72 in).

Rear

Fully adjustable Sachs shock absorber. Aluminium single-sided swinging arm.

Wheel travel:

138.5 mm (5.45 in).

Steering damper

Non-adjustable Sachs steering damper.

Exhaust system

Layout 4 - 2 - 1 - 2: the exhaust system structure is 4 into 2 into 1 into 2.

Lambda sensors: 4

Catalytic converters: 2

Available colours

Fairing

Ducati Anniversary red code 473.101 (PPG).
Base (Acriflex White) LMC06017 (LECHLER).
Grey frame and black rims.

Frame

Frame colour: grey.

Wheel rims

Colour: black.

Electric system

It consists of the following main components:

Instrument panel

TFT colour display.

Headlight

Low beam: no.2 LEDs;

High beam: no.2 LEDs;

Parking light/DRL (where fitted): No.6 LEDs.

Electrical controls on handlebar

Front turn indicators: No. 15 LEDs;

BULB front turn indicator type (USA version):

RY10W (12V-10W) Amber.

Rear turn indicators (Europe version): No. 1 LED;

BULB rear turn indicator type (USA version):

No. 1 RY10W (12V-10W) Amber Colour.

Rear lights

Tail light:

parking light: no.18 LEDs;

LED stop lights: no.18 LEDs;

Number plate light: no. 3 LEDs;

Horn.

Stop light switches.

Sealed electrolyte type battery:

YUASA YT 7B-BS (12V - 6.5 Ah)

Generator (Denso):

14V - 425W.

ELECTRONIC RECTIFIER, protected by a 30A fuse located on the solenoid starter, next to the battery.

Starter motor:

Denzo BA06 12V - 0.6 kW

Dashboard: digital with 5" TFT colour display.



Note

For bulb replacement instructions, please see the paragraph "Replacing the high and low beam bulbs".

Fuses

There are twelve fuses that protect the electric components, located inside the front fuse boxes, and one on the electric solenoid starter. There is a spare fuse in every box.

Refer to the table below to identify the circuits protected by the various fuses and their ratings.

The front left fuse box (A, Fig 199) and the front right one (B, Fig 200) are located above the battery.

To reach the fuses, remove the tank cover as described in chapter "Charging the battery".

To expose the fuses, lift the relevant box protective cover. Mounting position and ampere capacity are marked on box cover.

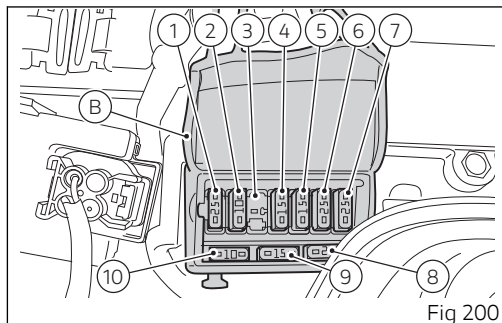
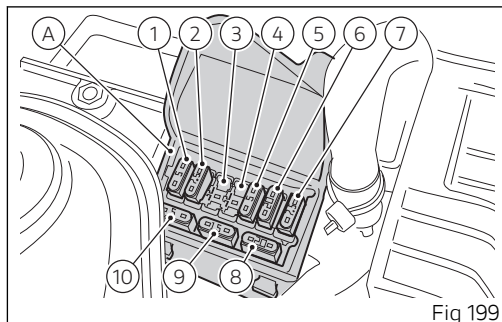

Front left fuse box (A) key		
Pos	El. item	Rat.
1	EMS/ABS/IMU	5 A
2	DASH/BBS/SMEC	7.5 A
3	-	-
4	-	-
5	Accessories/SW	5 A
6	Injection relay	20 A
7	Diagnostics/ Recharge	7.5 A
8	Spare	20 A
9	Spare	15 A
10	Spare	5 A

Front right fuse box (B) key		
Pos	El. item	Rat.
1	EMS powered relays	25 A
2	Fuel pump relay	10 A
3	-	-

Front right fuse box (B) key		
4	Instrument panel	15 A
5	Black Box System (BBS)	15 A
6	ABS UBMR	25 A
7	ABS UBVR	10 A
8	Spare	25 A
9	Spare	15 A
10	Spare	10 A

The main fuse (C) (30 A) and the spare one are located on the right side of the fuse box (B, Fig 200), on solenoid starter (D).

To reach it, it is necessary to remove the tank cover (remove the tank covers as described in chapter "Charging the battery") and the protection cap (E). The relay box (F) contains the line fuse (G) (30 A) that can be seen by removing the protection cap (H). A blown fuse can be identified by breakage of the inner filament (I).

⚠ Important
Switch the ignition key to OFF before replacing the fuse to avoid possible short-circuits.

⚠ Attention
Never use a fuse with a rating other than specified. Failure to observe this rule may damage the electric system or even cause fire.

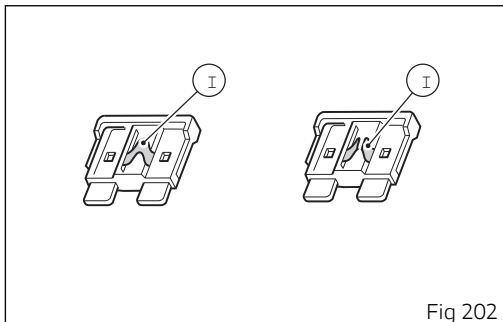
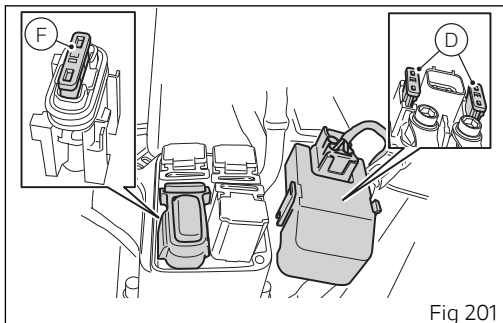

Open source software

Information about open source software

Some vehicle components use open source software. The source code used and information on open source is available online at the following link:
<https://www.ducati.com/ww/en/home/open-source-software>

Declarations of conformity

Declarations of conformity

EU Directive 2014/53/EU



Addresses of radio component manufacturers

All radio components must carry the manufacturer's address according to the provisions of directive 2014/53/EU. For components that, due to their size or nature, cannot be furnished with a sticker, the respective manufacturers' addresses as required by law are listed in the table 2.



Note

Only skilled person can access and install the device.

Table 1

Radio equipment installed in the vehicle	Frequency band	Max. transmission power
Instrument panel	134.6 KHz 119 KHz ÷ 135 KHz	< 66dB μ A/m (10m)
Ducati Multimedia System (Bluetooth)	2402 ÷ 2480 MHz	4.4mW
Antitheft	433.92MHz (\pm 75KHz)	<0.6mA
GPS	1575.4 MHz	

Table 2

Radio equipment installed in the vehicle	Manufacturers' addresses
Instrument panel	MAE Via Presolana 31/33 24030 Medolago (Bergamo), Italy
Ducati Multimedia System (Bluetooth)	COBO S.p.a. Via Tito Speri, 10 25024 Leno (BS), Italy
Antitheft	PATROLLINE Via Cesare Cantù, 15/C 22031 Albavilla (CO), Italy
GPS	DANFOSS A/S 6430 Nordborg Denmark CVR nr.: 20 16 57 15

Simplified EU declaration of conformity

[Austria]

Ihr Fahrzeug ist mit einer Reihe von Funkgeräten ausgestattet. Die Hersteller dieser Funkgeräte erklären, dass diese, wo gesetzlich vorgeschrieben, mit der Richtlinie 2014/53/EU übereinstimmen. Der vollständige Text der EU-Konformitätserklärung ist unter folgender Adresse verfügbar: certifications.ducati.com

[Belgium]

Votre véhicule est équipé d'une série d'appareillages radio. Les constructeurs de ces appareillages radio déclarent que ces derniers sont conformes à la directive 2014/53/UE lorsque la loi le requiert. Le texte complet de la déclaration de conformité UE est disponible à l'adresse suivante : certifications.ducati.com

[Bulgaria]

Твоят мотоциклет е оборудван с различна по вид радиоапаратура. Производителите на тази радиоапаратура декларираат, че тя съответства на Директива 2014/53/ЕС, съгласно изискванията по закон. Пълният текст на декларацията за съответствие ЕС, ще намерите на следния адрес: certifications.ducati.com

[Cyprus]

Το όχημά σας εξοπλίζεται με μια σειρά από ραδιοσυσκευές. Οι κατασκευαστές των συσκευών αυτών δηλώνουν ότι οι συσκευές συμμορφώνονται με την οδηγία 2014/53/ΕΕ, όπου απαιτείται από το νόμο. Το πλήρες κείμενο της δήλωσης συμμόρφωσης ΕΕ είναι διαθέσιμο στη διεύθυνση: certifications.ducati.com

[Czech Republic]

Vaše vozidlo je vybaveno řadou rádiových zařízení. Výrobci těchto radio zařízení, prohlašují, že zařízení jsou v souladu se směrnicí 2014/53/EU, pokud to vyžaduje zákon. Úplné znění prohlášení o shodě EU je k dispozici na internetových stránkách: certifications.ducati.com

[Germany]

Ihr Fahrzeug ist mit einer Reihe von Funkgeräten ausgestattet. Die Hersteller dieser Funkgeräte erklären, dass diese, wo gesetzlich vorgeschrieben, mit der Richtlinie 2014/53/EU übereinstimmen. Der vollständige Text der EU-Konformitätserklärung ist unter folgender Adresse verfügbar: certifications.ducati.com

[Denmark]

Dit køretøj er udstyret med et udvalg af radioudstyr. Producenterne af dette radioudstyr erklærer, at dette udstyr overholder direktiv 2014/53/EU, hvis det kræves i henhold til loven. Den komplette tekst af EU-overensstemmelseserklæringen findes på følgende webadresse: certifications.ducati.com

[Estonia]

Teie sõiduk on varustatud raadioseadmete seeriaga. Selle raadioseadme tootjad kinnitavad, et see seade vastab direktiivile 2014/53/EÜ, kui seadus seda nõuab. EÜ vastavusdeklaratsiooni terviktekst on saadaval järgmisel veebisaidil: certifications.ducati.com

[Spain]

Su vehículo está equipado con una serie de equipos de radio. Los fabricantes de dichos equipos de radio declaran su conformidad con la directiva 2014/53/UE, como requiere la ley. El texto completo de la declaración de conformidad UE está disponible en el siguiente sitio: certifications.ducati.com

[Finland]

Ajoneuvossasi on radiolaitteita. Näiden radiolaitteiden valmistajat vakuuttavat, että laitteet vastaavat direktiiviä 2014/53/EU lain edellyttämällä tavalla. EU-vaatimustenmukaisuusvakuutuksen täydellinen teksti on saatavilla seuraavasta osoitteesta: certifications.ducati.com

[France]

Votre véhicule est équipé d'une série d'appareillages radio. Les constructeurs de ces appareillages radio déclarent que ces derniers sont conformes à la directive 2014/53/UE lorsque la loi le requiert. Le texte complet de la déclaration de conformité UE est disponible à l'adresse suivante : certifications.ducati.com

[United Kingdom]

Your vehicle is equipped with a range of radio equipment. The manufacturers of this radio equipment declare that these equipment complies with Directive 2014/53/EU where required by law. The complete text of the EU declaration of conformity is available at the following web address: certifications.ducati.com

[Greece]

Το όχημά σας εξοπλίζεται με μια σειρά από ραδιοσυσκευές. Οι κατασκευαστές των συσκευών αυτών δηλώνουν ότι οι συσκευές συμμορφώνονται με την οδηγία 2014/53/ΕΕ, όπου απαιτείται από το νόμο. Το πλήρες κείμενο της δήλωσης συμμόρφωσης ΕΕ είναι διαθέσιμο στη διεύθυνση: certifications.ducati.com

[Croatia]

Vaše vozilo je opremljeno nizom radio uređaja. Proizvođači ovih radio uređaja tvrde da su uređaji u skladu s Direktivom 2014/53/UE ako je propisano zakonom. Cjelokupan tekst deklaracije o sukladnosti dostupan je na: certifications.ducati.com

[Hungary]

Járműved egy sor rádió készülékkel van felszerelve. Ezeknek a rádióberendezéseknek a gyártói kijelentik, hogy a készülékek megfelelnek a 2014/53/EU irányelvnek, ahol ezt a törvény megköveteli. Az EU megfelelőségi nyilatkozat teljes szövege az alábbi címen érhető el: certifications.ducati.com

[Ireland]

Your vehicle is equipped with a range of radio equipment. The manufacturers of this radio equipment declare that these equipment complies with Directive 2014/53/EU where required by law. The complete text of the EU declaration of conformity is available at the following web address: certifications.ducati.com

[Italy]

Il tuo veicolo è dotato di una serie di apparecchiature radio. I costruttori di queste apparecchiature radio dichiarano che esse sono conformi alla direttiva 2014/53/UE laddove richiesto per legge. Il testo completo della dichiarazione di conformità UE è disponibile al seguente indirizzo: certifications.ducati.com

[Lithuania]

Jūsų transporto priemonėje įdiegta daug įvairios radijo įrangos. Šios radijo įrangos gamintojai patvirtina, kad ji atitinka 2014/53/ES direktyvos reikalavimus, kaip tai numato galiojantys įstatymai. Visas ES atitikties deklaracijos tekstas pateikiamas svetainėje adresu certifications.ducati.com

[Luxembourg]

Votre véhicule est équipé d'une série d'appareillages radio. Les constructeurs de ces appareillages radio déclarent que ces derniers sont conformes à la directive 2014/53/UE lorsque la loi le requiert. Le texte complet de la déclaration de conformité UE est disponible à l'adresse suivante : certifications.ducati.com

[Latvia]

Jūsu transportlīdzeklis ir aprīkots ar dažādām radioierīcēm. Šo radioierīču ražotājs apliecina, ka ierīces atbilst Direktīvas 2014/53/ES prasībām, ja to paredz attiecīgie tiesību akti. Pilnīgo ES atbilstības deklarāciju skatiet šajā tīmekļa vietnē: certifications.ducati.com

[Malta]

Il-vettura tiegħek hija mgħammra b'firxa ta' tagħmir tar-radju. Il-manufatturi ta' dan it-tagħmir tar-radju jiddikjaraw li dan it-tagħmir jikkonforma mad-Direttiva 2014/53/UE fejn meħtieg mil-ligi. It-test kollu tad-dikjarazzjoni ta' konformità tal-UE huwa disponibbli fuq l-indirizz tal-web: certifications.ducati.com

[Netherlands]

Uw voertuig is voorzien van diverse draadloze apparatuur. De fabrikanten van deze draadloze apparatuur verklaren dat deze, daar waar dit door de wet voorschreven wordt, overeenstemmen met de richtlijn 2014/53/EU. De volledige tekst van de EU-verklaring van overeenstemming is beschikbaar op het volgende webadres: certifications.ducati.com

[Poland]

Państwa pojazd został wyposażony w szereg urządzeń radiowych. Producenci tych urządzeń radiowych oświadczają, że są one zgodne z dyrektywą 2014/53/UE, tam, gdzie wymaga tego prawo. Pełny tekst deklaracji zgodności UE jest dostępny pod następującym adresem internetowym: certifications.ducati.com

[Portugal]

O seu veículo é dotado de uma série de equipamentos de rádio. Os construtores desses equipamentos de rádio declaram que os mesmos estão em conformidade com a diretiva 2014/53/UE sempre que a lei o

determinar. O texto completo da declaração de conformidade UE está disponível no seguinte endereço: certifications.ducati.com

[Romania]

Vehiculul dvs. este dotat cu o serie de aparate radio. Producătorii acestor aparate radio declară că acestea sunt conforme cu directiva 2014/53/UE, dacă legea impune acest lucru. Textul complet al declarației de conformitate UE este disponibil la următoarea adresă: certifications.ducati.com

[Sweden]

Ditt fordon är utrustat med radioutrustning. Radioutrustningens tillverkare förklarar att denna utrustning uppfyller direktiv 2014/53/EU där så lagen kräver det. Fullständig text om EU-försäkran om överensstämmelse finns på följande adress: certifications.ducati.com

[Slovenia]

Vaše vozilo ima tudi vrsto radijske opreme. Proizvajalci eteh radijskih naprav izjavljajo, da so ti v skladu z uredbo 2014/53/UE, kjer zakon to predvideva. Celotno besedilo izjave o skladnosti EU je na voljo na spodnjem naslovu: certifications.ducati.com

[Slovakia]

Vaše vozidlo je vybavené rádiovými zariadeniami. Výrobcovia týchto rádiových zariadení prehlasujú, že tieto zariadenia sú v zhode so smernicou 2014/53/EÚ v rozsahu predpísanom zákonom. Úplný text ES prehlásenia o zhode je k dispozícii na nasledujúcej adrese: certifications.ducati.com

United States (USA)

"This device complies with Part 15 of the FCC Rules.

Operation is subject to the following two conditions: (1) this device may not cause harmful interference, and (2) this device must accept any interference received, including interference that may cause undesired operation."

"Changes or modifications not expressly approved by the party responsible for compliance could void the user's authority to operate the equipment." "NOTE: This equipment has been tested and found to comply with the limits for a Class B digital device, pursuant to Part 15 of the FCC Rules. These limits are designed to provide reasonable protection against harmful interference in a residential installation. This equipment generates, uses and can radiate radio frequency energy and, if not installed and used in accordance with the instructions, may cause harmful interference to radio communications. However, there is no guarantee that interference will not occur in a particular installation. If this equipment does cause harmful interference to radio or television reception, which can be determined by turning the equipment off and on, the user is encouraged to try to correct the interference by one or more of the following measures:

- Reorient or relocate the receiving antenna.
- Increase the separation between the equipment and receiver.
- Connect the equipment into an outlet on a circuit different from that to which the receiver is connected.
- Consult the dealer or an experienced radio/TV technician for help."

- RF exposure Information according 2.1091/2.1093 / OET bulletin 65:

Radiofrequency radiation exposure Information: This equipment complies with FCC radiation exposure limits set forth for an uncontrolled environment. This equipment should be installed and operated with minimum distance of 20 cm between the radiator and your body. This transmitter must not be co-located or operating in conjunction with any other antenna or transmitter.

The manufacturers of these radio equipment declare that devices comply with the FCC

DASHBOARD	FCC ID: 2AVGH-DSBV4HTG
Ducati Multimedia System (Bluetooth)	FCC ID: Z64-2564N

Canada

This device contains licence-exempt transmitter(s)/ receiver(s) that comply with Innovation, Science and Economic Development Canada's licence-exempt RSS(s). Operation is subject to the following two conditions:

- (1) This device may not cause interference.
- (2) This device must accept any interference, including interference that may cause undesired operation of the device.

L'émetteur/récepteur exempt de licence contenu dans le présent appareil est conforme aux CNR d'Innovation, Sciences et Développement économique Canada applicables aux appareils radio exempts de licence. L'exploitation est autorisée aux deux conditions suivantes:

- (1) L'appareil ne doit pas produire de brouillage;
- (2) L'appareil doit accepter tout brouillage radioélectrique subi, même si le brouillage est susceptible d'en compromettre le fonctionnement.

RF Exposure Information:

This equipment complies with Canada radiation exposure limits set forth for an uncontrolled environment. This equipment should be installed and operated with minimum distance of 20 cm between the radiator and your body.

Déclaration d'exposition aux radiations: Cet équipement est conforme aux limites d'exposition aux rayonnements IC établies pour un environnement non contrôlé. Cet équipement doit être installé et utilisé avec un minimum de 20 cm de distance entre la source de rayonnement et votre corps.

DASHBOARD	IC: 25794-DSBV4HTG
Ducati Multimedia System (Bluetooth)	IC: 4511-2564N

DASHBOARD

South Korea

해당 무선설비는 전파혼신 가능성이 있으므로 인명안전과 관련된 서비스는 할 수 없습니다



R-R-mAe- DSBV4HTG

DUCATI MULTIMEDIA SYSTEM (Bluetooth)

Brasil

Este equipamento opera em caráter secundário, isto é, não tem direito a proteção contra interferência prejudicial, mesmo de estações do mesmo tipo, e não pode causar interferência a sistemas operando em caráter primário. Para consultas, visite: www.anatel.gov.br.



07755-17-10873

Japan

当該機器には電波法に基づく、技術基準適合証明等を受けた特定無線設備を装着している。

This equipment contains specified radio equipment that has been certified to the technical regulation conformity certification under the Radio Law.

本無線機器の改造を禁ずる（これに反した場合は当該認証登録番号は無効となる）

This radio device should not be modified (otherwise the granted designation number will become invalid)

South Korea

해당 무선설비는 전파혼신 가능성이 있으므로 인명안전과 관련된 서비스는 할 수 없습니다



R-R-Cbo-1080795

91375721EN

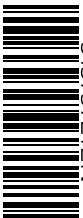



Ducati Motor Holding spa
ducati.com

Via Cavalieri Ducati, 3
40132 Bologna, Italy
Ph. +39 051 6413111
Fax +39 051 406580

A Sole Shareholder Company
A Company subject to the Management
and Coordination activities of AUDI AG