

Owner's manual

MONSTER 821



Owner's manual

ENGLISH

MONSTER 821

This manual forms an integral part of the motorcycle and must be kept with it for its whole service life. If the motorcycle is resold, the manual must always be handed over to the new owner. This manual must be preserved with care. If it is lost or becomes damaged, contact a Ducati Dealer or authorised Service Centre without delay to obtain a new copy of the manual.

The quality standards and safety of Ducati motorcycles are steadily improved as new design solutions, equipment and accessories are developed. While the information contained in this manual is current at the time of going to print, Ducati Motor Holding S.p.A. reserves the right to make changes at any time without notice and without any obligations. For this reason, the illustrations in this manual might differ from your motorcycle.

Any and all reproduction or spreading of the contents herein in whole or in part is forbidden. All rights reserved to Ducati Motor Holding S.p.A. Any request for written authorisation shall be addressed to this company, specifying the reasons for request.

Enjoy your ride!

Table of contents

Introduction	7
Safety guidelines	7
Warning symbols used in the manual	8
Intended use	9
Rider's obligations	10
Rider's training	12
Apparel	12
Safety "Best Practices"	13
Refuelling	15
Carrying the maximum load allowed	16
Dangerous products - warnings	17
Vehicle identification number	19
Engine identification number	20
Instrument panel (Dashboard)	21
Instrument panel	21

Acronyms and abbreviations used in the Manual	26
Technological Dictionary	26
Information statement on UE directive 2014/53/UE	28
Function buttons	31
Parameter setting and displaying	32
Main functions	45
Engine rpm indication (RPM)	47
Motorcycle speed	50
Gear	51
Riding Mode (RIDING MODE)	52
DTC	57
ABS	62
Menu functions	67
Odometer (TOT)	69
Trip meter 1 (TRIP 1)	70
Trip meter 2 (TRIP 2)	71
Residual range (RANGE)	72
LAP TIME	73
Engine Coolant temperature	76
Instantaneous fuel consumption	78
Average fuel consumption	79
Average speed	80
Trip time	81
Ambient air temperature	82

- Clock 83
- Auxiliary functions 84
- Infotainment 85
- Service indication (SERVICE) 96
- OIL SERVICE zero warning 97
- OIL SERVICE or ANNUAL SERVICE or DESMO SERVICE countdown indication 98
- OIL SERVICE or ANNUAL SERVICE or DESMO SERVICE indication 99
- Warnings/Alarms (WARNING) 100
- Error warnings 105
- Viewing side stand status 107
- Setting menu 108
- Customising the RIDING MODE 110
- Customizing the Riding Mode: ABS adjustment 112
- Customizing the Riding Mode: setting the DTC level 115
- Customizing the Riding Mode: engine adjustment 118
- Customizing the Riding Mode: restoring default settings 121
- Display mode setting 125
- Display backlighting setting 127
- PIN CODE 130
- Changing the PIN CODE 134
- LAP 138
- Setting the units of measurement 143
- Date setting 152
- Clock setting 158
- Bluetooth device setting 162
- Service information 173
- Information (INFO) 174
- Tire Setting 175
- Display backlighting colour 181
- Light control 182
- Immobilizer system 186
- Keys 187
- Operation 188
- Key duplication 189
- Restoring motorcycle operation via the PIN CODE 190
- Controls 194**
- Position of motorcycle controls 194
- Ignition switch and steering lock 195
- Left-hand switch 196
- Clutch lever 197
- Right-hand switch 200
- Throttle twistgrip 201
- Front brake lever 202

Rear brake pedal 203
Gear change pedal 204
Adjusting the position of the gearchange
pedal and rear brake pedal 205

Main components and devices 207

Position on the vehicle 207
Tank filler plug 208
Seat lock 209
Seat height adjustment 210
Helmet cable 214
Side stand 215
Rear shock absorber adjusters 216

Riding the motorcycle 219

Running-in recommendations 219
Pre-ride checks 221
Engine start 223
Moving off 225
Braking 226
Stopping the motorcycle 228
Refuelling 229
Parking 231
Tool kit and accessories 232

Main use and maintenance operations 233

Checking coolant level and topping up, if
necessary 233
Changing the air filter 234
Check brake fluid level 235
Checking brake pads for wear 236
Charging the battery 237
Charging and maintenance of the battery
during winter storage 240
Removing the battery 242
Refitting the battery 249
Checking drive chain tension 255
Lubricating the drive chain 257
Changing bulbs 262
Aligning the headlight 263
Tyres 265
Check engine oil level 268
Cleaning and replacing the spark plugs 270
Cleaning the motorcycle 271
Storing the motorcycle 273
Important notes 273

Scheduled maintenance chart 274

Scheduled maintenance chart: operations to be carried out by the dealer 274
Scheduled maintenance chart: operations to be carried out by the customer 278

Routine maintenance record 296
Routine maintenance record 296

Technical data 279

Weights 279
Dimensions 280
Fuel, lubricants and other fluids 281
Engine 283
Timing system 284
Performance data 285
Spark plugs 285
Fuel system 285
Brakes 286
Transmission 287
Frame 288
Wheels 288
Tyres 288
Suspension 288
Exhaust system 288
Available colours 288
Electric system 290

Introduction

Safety guidelines

We would like to welcome you among Ducati enthusiasts, and congratulate you on your excellent choice of motorcycle. We think you will ride your Ducati motorcycle for long journeys as well as short daily trips. Ducati Motor Holding S.p.A. wishes you smooth and enjoyable riding.

Your motorcycle is the result of Ducati Motor Holding S.p.A.'s on-going research and development efforts. It is important that you preserve its quality standard by strictly observing the maintenance plan and using genuine spare parts. This manual provides instructions on minor maintenance operations. Major maintenance operations are described in the Workshop Manual available to Ducati Authorised Service Centres. In your own interest, for your safety and in order to guarantee product reliability, you are strongly advised to refer to our authorised Dealers and

Service Centres for any operations listed in the scheduled maintenance chart, see page 274.

Our highly skilled staff have access to special implements and appropriate equipment required to perform any servicing job at best, and use Ducati original spare parts only as the best guarantee for full interchangeability, smooth running and long life.

All Ducati motorcycles come with a Warranty Card. The warranty does not apply to motorcycles used in racing competitions.

Tampering with or altering any components, even partially, will make the warranty null and void effective immediately. Improper or poor maintenance, using other than original spare parts or parts not expressly approved by Ducati may invalidate your warranty rights and lead to damage or loss of performance.

Your safety and that of other road users are very important. Ducati Motor Holding S.p.A. recommends that you ride responsibly. Before using your motorcycle for the first time, read this entire manual carefully and closely follow the guidelines outlined in it. The manual provides full information on proper motorcycle operation and

maintenance. In case of any doubts, please contact a Dealer or Authorised Service Centre.

The terms RIGHT and LEFT are referred to the motorcycle viewed from the riding position.

Warning symbols used in the manual

Several kinds of warnings are used as an alert of the possible hazards for you or other persons such as:

- Safety labels on the motorcycle;
- Safety messages preceded by a warning symbol and either WARNING or IMPORTANT.

Attention

Failure to comply with these instructions may put you at risk, and could lead to severe injury or even death of the rider or other persons.

Important

Possibility of damaging the motorcycle and/or its components.

Note

Additional information about the current operation.

Intended use

This motorcycle must be ridden on asphalt or on flat and even surfaces, only.

This motorcycle may not be used for riding on dirt trails or for off-road riding.

Attention

Off-road riding may lead to loss of control and result in vehicle damage, personal injuries or even death.

Attention

This motorcycle may not be used to tow any trailers or with a side-car attached; this can lead to loss of control and result in an accident.

This motorcycle carries the rider and can carry a passenger.

Attention

The total weight of the motorcycle in running order including rider, passenger, luggage and additional accessories should not exceed 390kg/ 859lb.

Important

Using the motorcycle under extreme conditions, such as very damp and muddy roads or dusty and dry environment, could cause above-average wear of components like the drive system, the brakes or the air filter. If the air filter is dirty, the engine could get damaged. Therefore, this might translate in required service or replacement of the wear parts earlier than specified in the scheduled maintenance chart.

Rider's obligations

All riders must hold a valid licence.



Attention

Riding without a licence is illegal and is prosecuted by law. Always make sure you have your licence with you when riding. Do not let inexperienced riders or persons without a valid licence use your motorcycle.

Do not ride under the influence of alcohol and/or drugs.



Attention

Riding under the influence of alcohol and/or drugs is illegal and is prosecuted by law.

Do not take prescription or other drugs before riding unless you have consulted your doctor about their side effects.



Attention

Some medications and drugs may cause drowsiness or other effects that slow down reaction time and the rider's ability to control the motorcycle, possibly leading to an accident.

Some states require vehicle insurance.



Attention

Check your state laws. Obtain insurance coverage and keep your insurance document secure with the other motorcycle documents.

To protect rider and passenger safety, some states mandate the use of a certified helmet.



Attention

Check your state laws. Riding without a helmet may be punishable by law.



Attention

Riders without helmets are more likely to suffer severe bodily injury or die if they are in an accident.



Attention

Check that your helmet complies with safety specifications, permits good vision, is the right size for your head, and carries a certification label indicating that it conforms to the standards in force in your state. Road traffic laws differ from state to state. Learn about traffic laws in your state before riding and always obey them.



Important

Before using the motorcycle, check for no labels on the rear-view mirrors; otherwise remove them.

Rider's training

Accidents are frequently due to inexperience. Riding, manoeuvres and braking must be performed in a different way than on the other vehicles.



Attention

Untrained riders or a wrong use of the vehicle may lead to loss of control, serious injuries or even death.

Apparel

Riding gear is very important for safety. Unlike cars, a motorcycle offers no impact protection in an accident.

Proper riding gear includes helmet, eye protection, gloves, boots, long sleeve jacket and long trousers.

- The helmet must meet the requirements listed at page 10; if your helmet does not have a visor, use suitable eye wear;
- Use five-finger gloves made from leather or abrasion-resistant material;
- Riding boots or shoes must have non-slip soles and offer ankle protection;

- Jacket, trousers or riding suit must be made from leather or abrasion-resistant material and have high-visibility colours and inserts.



Important

Never wear loose clothing, items or accessories that may become tangled in motorcycle parts.



Important

For your safety, always wear suitable protective gear, regardless of season and weather.



Important

Have your passenger wear proper protective clothing.

Safety "Best Practices"

These few simple operations are critical to people safety and to preserving the full performance of your motorcycle. Never forget to perform them before, while and after riding.

Important

Closely follow the indications provided at chapter "Riding the motorcycle" during the running-in period.

Failure to follow these instructions releases Ducati Motor Holding S.p.A. from any liability whatsoever for any engine damage or shorter engine life.

Attention

Before riding your motorcycle, become familiar with the controls you will need to use when riding.

Perform the checks recommended in this manual before each ride (see page 221).

Attention

Failure to carry out these checks before riding may lead to motorcycle damage and injury to rider and/or passenger.

Attention

Start the engine outdoors or in a well ventilated area. The engine should never be started or run indoors.

Exhaust gases are poisonous and may lead to loss of consciousness or even death within a short time. Use proper body position while riding and ensure your passenger does the same.

Important

Rider must hold the handlebar with both hands at ALL TIMES while riding.

Important

Both rider and passenger should keep their feet on the footpegs when the motorcycle is in motion.

Important

The passenger should always hold on to the grab handles under the seat with both hands.



Important

Be very careful when tackling road junctions, or when riding in areas near exits from private grounds, car parks or on slip roads to access motorways.



Important

Be sure you are clearly visible and do not ride within the blind spot of vehicles ahead.



Important

ALWAYS signal your intention to turn or pull to the next lane in good time using the suitable turn indicators.



Important

Park your motorcycle where no one is likely to knock against it, and use the side stand. Never park on uneven or soft ground, or your motorcycle may fall over.



Important

Visually inspect the tyres at regular intervals for detecting cracks and cuts, especially on the side walls, bulges or large spots that are indicative of internal damage. Replace them if badly damaged. Remove any stones or other foreign bodies caught in the tread.



Attention

Engine, exhaust pipes and silencers stay hot long after the engine is switched off; pay particular attention not to touch the exhaust system with any body part and do not park the vehicle next to flammable material (wood, leaves etc.).



Attention

Always remove the key when you leave your motorcycle unattended and make sure it is not accessible to persons not authorised to use the motorcycle.

Refuelling

Fuel label

Fuel identification label

Refuel outdoors with engine off.

Do not smoke or use open flames while refuelling. Be careful not to spill fuel on engine or exhaust pipe. Never completely fill the tank when refuelling. Fuel should never be touching the rim of filler recess. When refuelling, avoid breathing the fuel vapours and prevent fuel from reaching your eyes, skin or clothes.

Attention

The motorcycle is only compatible with fuel having a maximum content of ethanol of 10% (E10). Using fuel with ethanol content over 10% is forbidden. Using it could result in severe damage of the engine and motorcycle components. Using fuel with ethanol content over 10% will make the warranty null and void.

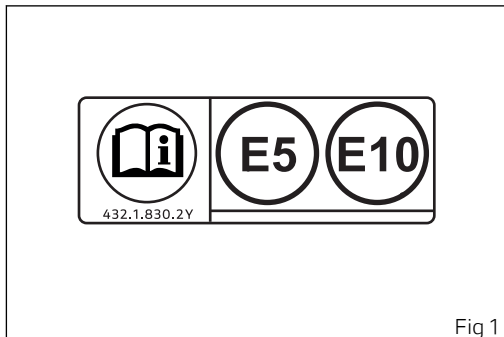

Fig 1

Attention

In case of indisposition caused by breathing fuel vapours for a long time, stay in the open air and contact your doctor. In case of contact with eyes, thoroughly flush with water; in case of contact with skin, immediately clean with water and soap.

Attention

Fuel is highly flammable, in case of accidental spillage of fuel on your clothes it is necessary to change into clean clothes.

Carrying the maximum load allowed

Your motorcycle is designed for long-distance riding, carrying the maximum load allowed in full safety. Even weight distribution is critical to preserving these safety features and avoiding trouble when performing sudden manoeuvres or riding on bumpy roads.

Attention

Do not exceed the total permitted weight for the motorcycle and pay attention to information provided below regarding load capacity.

Information about carrying capacity

Important

Arrange your luggage or heavy accessories in the lowest possible position and close to motorcycle centre.

Important

Never fix bulky or heavy objects to the handlebar or to the front mudguard as this would affect stability and cause danger.

Important

Be sure to secure the luggage to the supports provided on the motorcycle as firmly as possible. Improperly secured luggage may affect stability.

Important

Do not insert any objects you may need to carry into the gaps of the frame as these may foul moving parts.

Attention

Make sure the tyres are inflated to the proper pressure and that they are in good condition.

Refer to paragraph "Tyres" on page 265.

Attention

The total weight of the motorcycle in running order including rider, passenger, luggage and additional accessories should not exceed 390kg/ 859lb.

Dangerous products - warnings

Used engine oil

Attention

Prolonged or repeated contact with used engine oil may cause skin cancer. If working with engine oil on a daily basis, we recommend washing your hands thoroughly with soap immediately afterwards. Keep away from children.

Brake dust

Never clean the brake assembly using compressed air or a dry brush.

Brake fluid

Attention

Spilling brake fluid onto plastic, rubber or painted parts of the motorcycle may cause damages. Protect these parts with a clean shop cloth before proceeding to service the system. Keep away from children.

Attention

The fluid used in the brake system is corrosive. In the event of accidental contact with eyes or skin, wash the affected area with abundant running water.

Coolant

Engine coolant contains ethylene glycol, which may ignite under particular conditions, producing invisible flames. Although the flames from burning ethylene glycol are not visible, they are still capable of causing severe burns.

Attention

Take care not to spill engine coolant on the exhaust system or engine parts.

These parts may be hot and ignite the coolant, which will subsequently burn with invisible flames. Coolant (ethylene glycol) is irritant and poisonous when ingested. Keep away from children. Never remove the radiator cap when the engine is hot. The coolant is under pressure and will cause severe burns.

The cooling fan operates automatically: keep hands well clear and make sure your clothing does not snag on the fan.

Battery



Attention

The battery gives off explosive gases; never cause sparks or allow naked flames and cigarettes near the battery. When charging the battery, ensure that the working area is properly ventilated.

Vehicle identification number



Note

These numbers identify the motorcycle model and should always be indicated when ordering spare parts.

It is recommended to record the frame number of your motorcycle in the space below.

Frame number

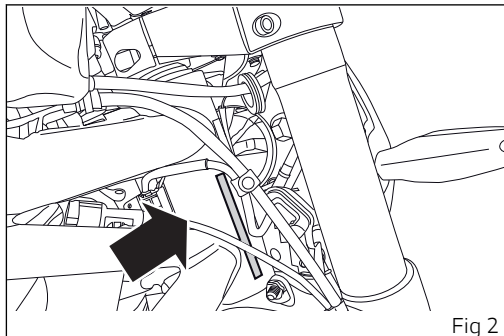

Fig 2

Engine identification number

Note

These numbers identify the motorcycle model and should always be indicated when ordering spare parts.

It is recommended to record the number of your motorcycle's engine in the space below.

Engine number

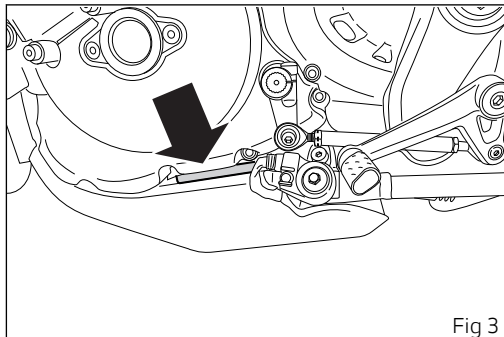

Fig 3

Instrument panel (Dashboard)

Instrument panel

1) Display.

2) NEUTRAL LIGHT N (GREEN).

Comes on when in neutral position.

3) HIGH BEAM LIGHT  (BLUE).

It turns on to indicate that the high beam lights are on and when the flasher is activated.

4) ENGINE OIL PRESSURE LIGHT  (RED).

Comes on when engine oil pressure is too low. It must turn on at "KEY-ON", but must turn off a few seconds after the engine has started. It may shortly come on when the engine is hot, however, it should go out as the engine revs up.

Important

If the ENGINE OIL light stays ON, stop the engine or it may suffer severe damage.

5) FUEL WARNING LIGHT  (AMBER YELLOW).

Comes on when fuel is low (see chapter "Top-ups").

6) TURN INDICATOR LIGHTS  (GREEN).

Illuminates and flashes when the turn indicator is in operation.

7) "ENGINE DIAGNOSIS - EOBD" LIGHT

 (AMBER YELLOW).

It turns on in the case of "engine" errors and in some cases will lock the engine.

8) GENERAL WARNING LIGHTS (RED).

The lights turn on when RPM value reaches the first threshold before the rpm limiter kicks in;

9) ABS LIGHTS  (AMBER YELLOW).

This turns on to indicate that ABS is disabled or not functioning.

Engine off/ speed below 3 mph (5 km/h)		
Light OFF	Light flashing	Light steady on
-	ABS disabled with the menu function "ABS"	ABS enabled, but not functioning yet
Engine on/ speed below 3 mph (5 km/h)		
Light OFF	Light flashing	Light steady on
-	ABS enabled, but not functioning yet	ABS enabled, but not functioning due to a problem
Engine ON / speed above 5 km/h (3 mph)		
Light OFF	Light flashing	Light steady on
ABS enabled and functioning	ABS enabled and degraded due to a problem	ABS enabled, but not functioning due to a problem

10) GENERIC ERROR WARNING LIGHT (AMBER YELLOW).

It turns on when there are any "vehicle" errors, i.e. active errors triggered by any control unit other than the engine control unit.

11) DTC STATUS LIGHT (AMBER YELLOW).

This light indicates DTC system enabling/disabling status.

Speed below or equal to 5 Km/h (3 mph)		
Light OFF	Light flashing	Light steady on
DTC enabled and functioning	DTC enabled, but not functioning yet	DTC disabled and/or not functioning due to a fault in the BBS control unit
Speed above 5 Km/h (3 mph)		
Light OFF	Light flashing	Light steady on
DTC enabled and functioning	DTC enabled but there is a fault in the system causing inhibited performance	DTC disabled and/or not functioning due to a fault in the BBS control unit

12) DTC INTERVENTION (AMBER YELLOW).

	DTC
No intervention	Light OFF
Spark advance cut	Light steady ON
Injection cut	Light steady ON

13) OVER REV / IMMOBILIZER / ANTI-THEFT SYSTEM (RED)

	Over rev
No intervention	Light OFF
First threshold (N RPM before the limiter kicks in)	Light steady ON
Limiter	Light ON flashing



Note

Each calibration of the Engine Control Unit may have a different setting for the thresholds that precede the rev limiter and the rev limiter itself.

	Immobilizer
--	--------------------

Key-ON status	Light OFF
Key-OFF status	Light ON flashing
Key-OFF status for over 12 hours	Light OFF



Important

If the display shows the message "TRANSPORT MODE", immediately contact your Ducati Dealer that will delete this message and ensure the full operation of the motorcycle.

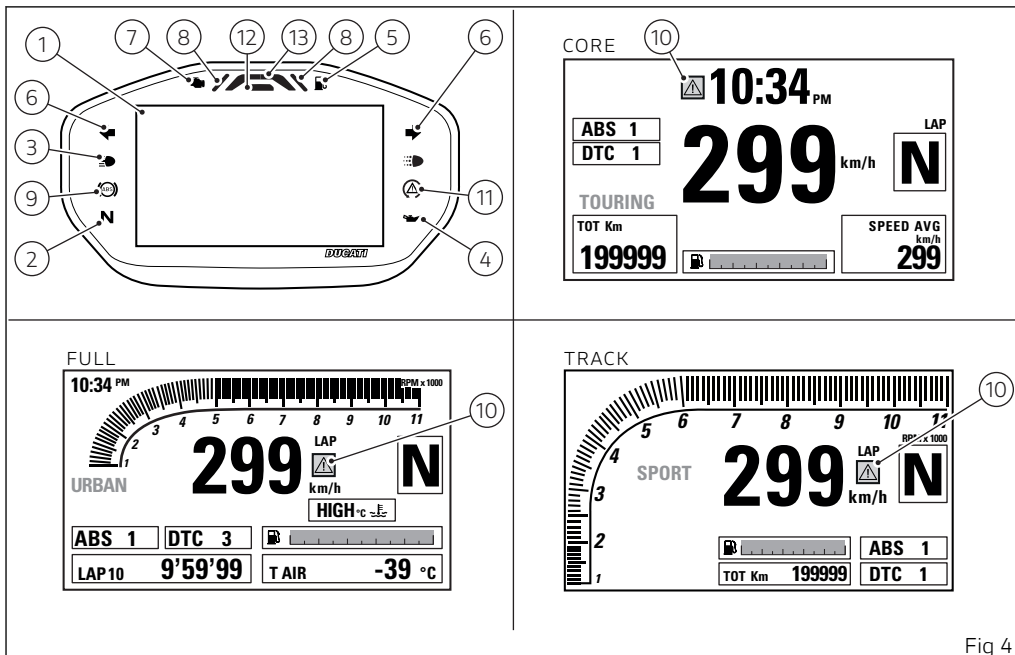

Fig 4

Acronyms and abbreviations used in the Manual

ABS

Antilock Braking System

BBS

Black Box System

CAN

Controller Area Network

DDA

DUCATI Data Acquisition

DSB

Dashboard

DTC

DUCATI Traction Control

EBC

DUCATI Engine Brake Control

ECU

Engine Control Unit

GPS

Global Positioning System

Technological Dictionary

Riding Mode

The rider can choose from 3 different preset bike configurations (Riding Modes) and pick the one that

best suits his/her riding style or ground conditions. The Riding Modes allow user to instantly change the engine power delivery (Power Mode), ABS, DTC settings and instrument panel graphics.

Available Riding Modes: Sport, Touring and Urban. Within every Riding Mode, the rider can customise any settings.

Power Mode

The Power Modes are the different engine maps the rider can select to change power level and delivery to suit his/her own riding style and surface conditions. There are three Power Modes, one for each Riding Mode:

- LOW, with 'soft' power delivery;
- MED, with 'soft' power delivery;
- HIGH, with 'instant' power delivery.

Ride by Wire (RbW)

The Ride by Wire system is the electronic device that controls throttle opening and closing. Since there is no mechanical connection between the throttle twistgrip and the throttle bodies, the ECU can adjust power delivery by directly affecting throttle opening angle.

The Ride by Wire system allows you to obtain different power level and delivery according to the selected Riding Mode (Power Mode), but even to accurately control the engine brake (EBC), thereby helping to control the rear wheel slipping (DTC).

Ducati Traction Control (DTC)

The Ducati Traction Control system (DTC) supervises the rear wheel slipping control and settings vary through eight different levels that are programmed to offer a different tolerance level to rear wheel slipping. Each Riding Mode features a pre-set intervention level.

Level eight indicates system intervention whenever a slight slipping is detected, while level one is for very expert riders because it is less sensitive to slipping and intervention is hence softer.

Anti-lock Braking System (ABS)

The ABS system fitted to the Monster 821 is a safety system preventing wheel lockup while riding with the motorcycle not leaning over. The Monster ABS also features a "cornering" function that widens ABS functionality to the conditions where the motorcycle is leaning over, thus preventing wheel lockup and slipping as much as possible, within the physical

limits allowed by the vehicle and by the road conditions.

The Monster 821 ABS implements rear wheel lift-up control in order to ensure not only smaller stopping distance under braking, but also the best possible stability.

These functions are divided into 3 different levels, each associated with a Riding Mode. ABS can be disabled.

Information statement on UE directive 2014/53/UE

Simplified EU declaration of conformity

Your vehicle is equipped with a range of radio equipment. The manufacturers of this radio equipment declare that this equipment complies with Directive 2014/53/EU where required by law.

The complete text of the EU declaration of conformity is available at the following web address:
certifications.ducati.com

Manufacturers' addresses

All relevant components pursuant to 2014/53/EU must bear the manufacturer's address. For components that, due to their size or nature, cannot be furnished with a sticker, the respective manufacturers' addresses as required by law are listed here:

Radio equipment installed in the vehicle	Manufacturers' addresses
Bluetooth/DSB	COBO S.p.a. Via Tito Speri, 10 25024 - Leno (BS) Italy
Hands free	ZADI S.p.a. Via Carl Marx, 138 41012 - Carpi (MO) Italy
Hands free	ASHAI DENSO 6-2-1 Somejidai, Hamakita-ku, Hamamatsu, Shizuoka 434-0046 Japan
Djair®	Dainese S.p.a. Via dell'Artigianato, 35 36060 - Molvena (VI) Italy
E-Lock	ZADI S.p.a. Via Carl Marx, 138 41012 - Carpi (MO) Italy
GPS	PROSA S.r.l. Via dell'Elettricità, 3/d 30175 - Venezia Marghera (VE) Italy

DSB	MAE Via Presolana 31/33 24030 - Medolago – Bergamo - Italy
DSB	EGICON Via Posta Vecchia, 36, Mirandola (MO) - Italy
TPMS	LDL Technology S.A.S. Parc Technologique du Canal, 3 rue Giotto 31520 Ramonville - France
TPMS	PACIFIC Industrial Co., Ltd. 1300-1 Yokoi, Godo-cho, Anpachi-gun, Gifu 503-2397, JAPAN
Anti-theft system	PATROLLINE Via Cesare Cantù, 15/C Albavilla (CO) - Italy

Radio equipment	Frequency band	Max. transmission power
Bluetooth	2,402 MHz ÷ 2,480 MHz	4.4 mW
Hands free unit	134.2 KHz (AD) 134.5 KHz (Zadi) (129.6 – 135 kHz)	73dB μ V/m (10m) <66 dB μ A/m (10m)
Hands free key	868.35 MHz (Zadi) (868 – 868.5 MHz) 434 MHz (AD)	<25mW e.r.p. -20 dBm (3m)
D air [®]	868 MHz 2.4 GHz	+10 dB +3 dB
E-Lock	134.5 KHz (129.6 – 135 kHz)	<66 dB μ A/m (10m)
GPS	1575.4 MHz	
DSB	134.2 KHz 120 KHz – 140 KHz	178.5 dB μ A/m <66 dB μ A/m (10m)
TPMS	868.35 MHz (LDL) 433.05 ÷ 434.79MHz (Pacific)	-7 dBm +/- 4 dB 100 dB μ V/m
Anti-theft system	433.92 MHz (\pm 75 KHz)	<0.6 mA

Function buttons

1) UP CONTROL SWITCH "▲"

Button used to display and set instrument panel parameters with the position "▲".

2) DOWN CONTROL SWITCH "▼"

Button used to display and set instrument panel parameters with the position "▼".

3) HIGH-BEAM FLASH BUTTON (FLASH)

The high-beam flash button may also be used for LAP functions.

4) TURN INDICATORS CANCEL BUTTON

The turn indicators cancel button may also be used for the CONFIRM MENU function, for selecting the riding mode.

5) HAZARD BUTTON

Button used to switch on/off all four turn indicators (Hazard function).

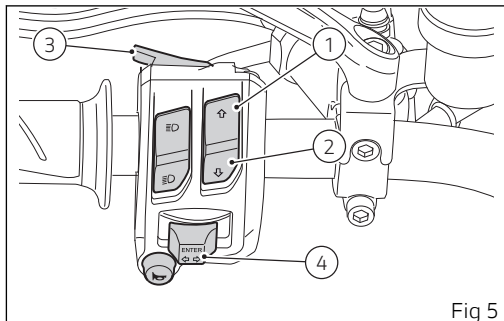

Fig 5

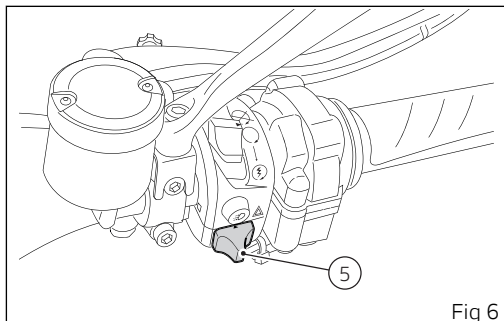

Fig 6

Parameter setting and displaying

Upon key-on, the instrument panel displays the DUCATI logo and switches on the LED warning lights in two steps ("initial check routine").

After this routine, the instrument panel displays the main page in one of the available layouts (CORE, FULL or TRACK), depending on the one in use before last KEY-OFF.

During this first check stage, if the motorcycle speed exceeds 10 km/h (6 mph) (actual speed), the instrument panel will stop:

- the display check routine and display the standard screen containing updated information;
- the warning light check routine and leave ON only the warning lights that are actually active at the moment.

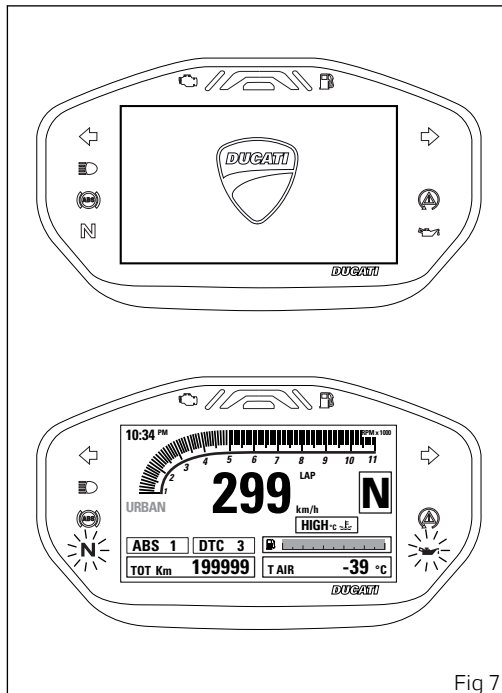

The main page can have three different layouts: CORE, FULL and TRACK.

Data displayed on the main screen for CORE layout are as follows:

- 1) ABS ON/OFF indication.
- 2) Clock.
- 3) DTC level indication (ON) or DTC OFF indication.
- 4) Menu 1 (Odometer, Trip 1, Trip 2, Player On / Off - active only if the Bluetooth module is available and at least one Smartphone is connected - Range, Trip time, Lap time - only if active, Heated handgrips - active only if present).
- 5) Motorcycle speed.
- 6) Set Riding Mode.
- 7) Menu 2 (Ambient air temperature, Engine temperature, Average consumption, Instant fuel consumption, Average speed).
- 8) LAP indication (only if active).
- 9) Gear indication.
- 10) Fuel level.

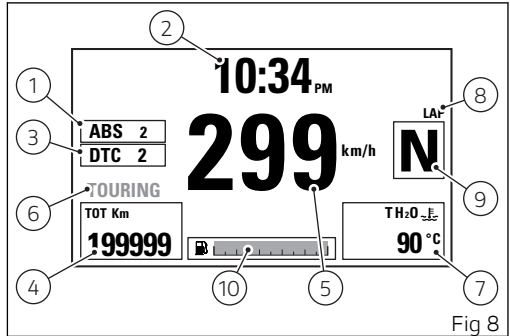

Data displayed on the main screen for FULL layout are as follows:

- 1) ABS ON/OFF indication.
- 2) Clock.
- 3) DTC level indication (ON) or DTC OFF indication.
- 4) Fuel level.
- 5) Menu 1 (Odometer, Trip 1, Trip 2, Player On / Off - active only if the Bluetooth module is available and at least one Smartphone is connected - Range, Trip time, Lap time - only if active, Heated handgrips - active only if present).
- 6) Motorcycle speed.
- 7) Set Riding Mode.
- 8) Menu 2 (Ambient air temperature, Instantaneous fuel consumption, Average fuel consumption, Average speed).
- 9) LAP indication (only if active).
- 10) Rpm bargraph.
- 11) Gear indication.
- 12) Engine coolant temperature indication.

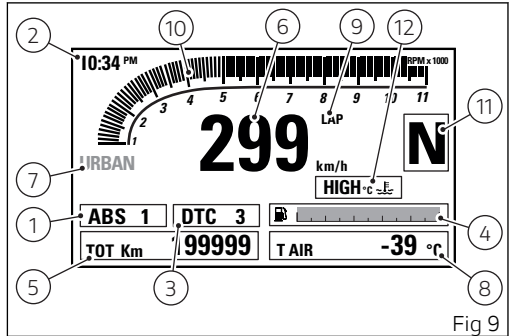
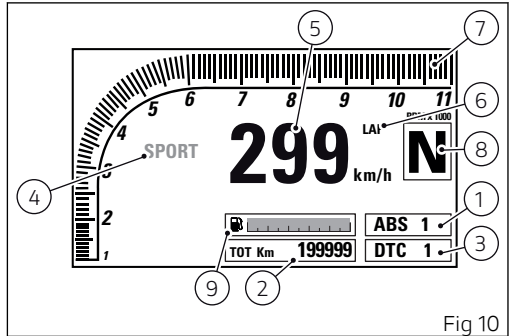

Fig 9

Data displayed on the main screen for TRACK layout are as follows:

- 1) ABS ON/OFF indication.
- 2) Menu 1 (Odometer, Trip meter 1, Trip meter 2, Range, Average consumption, Instant consumption, Average speed, Trip time, Clock, Lap time - only if active, Ambient air temperature, Engine temperature, Heated handgrips - active only if present).
- 3) DTC level indication (ON) or DTC OFF indication.
- 4) Set Riding Mode.
- 5) Motorcycle speed.
- 6) LAP indication (only if active).
- 7) Rpm bargraph.
- 8) Gear indication.
- 9) Fuel level.



From the main screen, with CORE layout, press button (1) on LH switch to view Menu 1 information.

- Odometer (TOT);
- TRIP 1 (Trip meter 1);
- TRIP 2 (Trip meter 2);
- Player On / Off - active only if the Bluetooth module is available and at least one Smartphone is connected;
- RANGE;
- TRIP TIME (Trip time);
- LAP time (only if active) – displayed for 6s;
- Heated handgrips - active only if present (H.Grips).

Press button (2) on LH switch to view Menu 2 information.

- Air temperature;
- Engine Coolant temperature;
- Average Fuel Consumption (CONS. AVG);
- Instantaneous fuel consumption (CONS.I);
- Average speed (SPEED AVG).

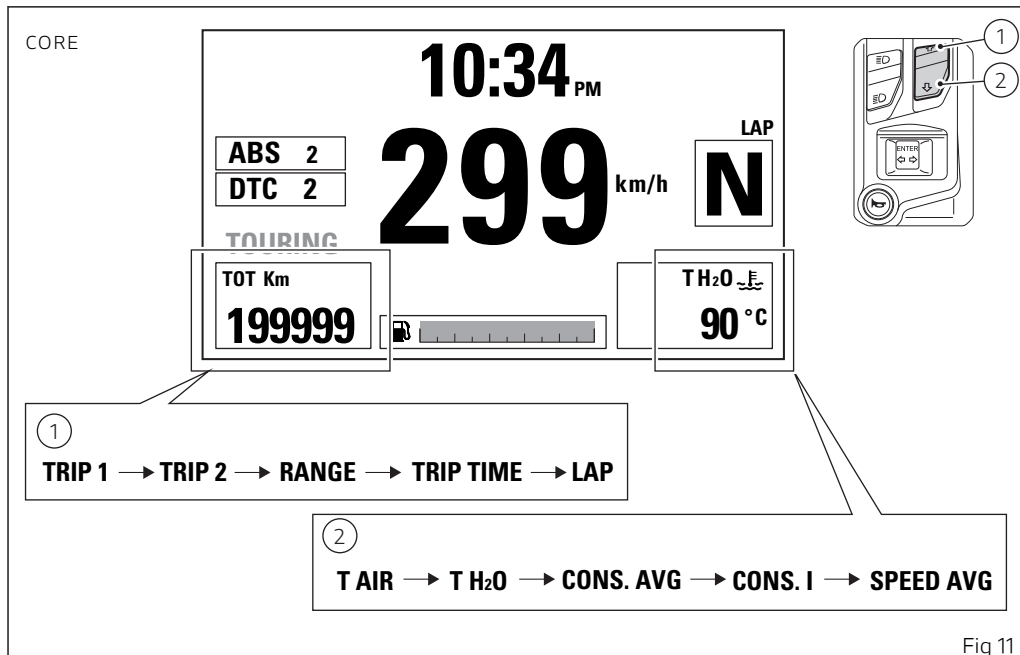

Fig 11

From the main screen, with FULL layout, press button (1) on LH switch to view Menu 1 information.

- Odometer (TOT);
- TRIP 1;
- TRIP 2;
- Player On / Off - active only if the Bluetooth module is available and at least one Smartphone is connected;
- RANGE;
- TRIP TIME;
- Lap time (LAP) (if function is active);
- Heated handgrips - active only if present (H.Grips).

Press button (2) on LH switch to view Menu 2 information.

- Air temperature;
- Instantaneous fuel consumption (CONS.I);
- Average Fuel Consumption (CONS. AVG);
- Average speed (SPEED AVG).

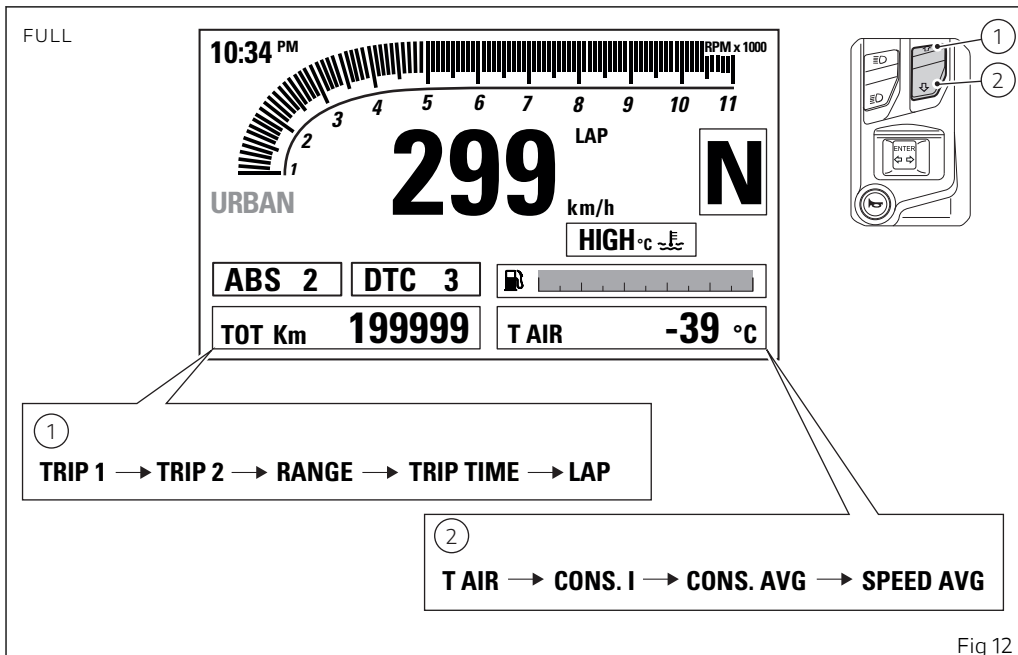

From the main screen, with TRACK layout, press button (1) on LH switch to view Menu 1 information.

- Odometer (TOT);
- TRIP 1;
- TRIP 2;
- RANGE;
- Average Fuel Consumption (CONS. AVG);
- Instantaneous fuel consumption (CONS.I);
- Average speed (SPEED AVG);
- TRIP TIME;
- Clock;
- Lap time (LAP) (if function is active);
- Air temperature;
- Engine Coolant temperature;
- Heated handgrips - active only if present (H.Grips).

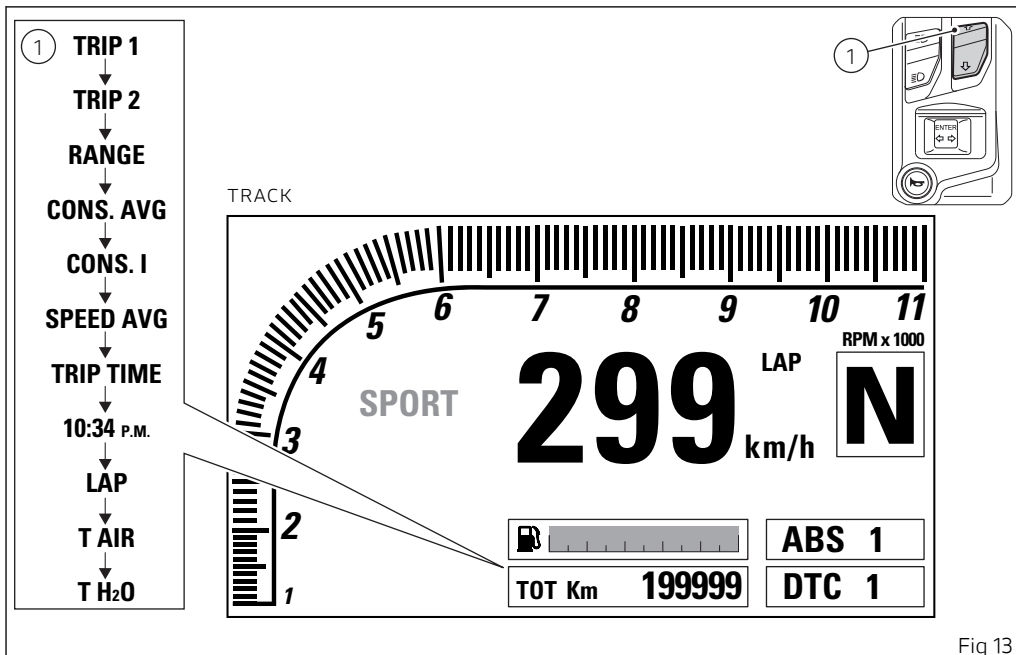

Fig 13

The instrument panel stores Menu 1 and Menu 2 settings in use upon KEY-OFF. On the following KEY-ON, previously stored Menu 1 e Menu 2 pages are displayed.

In case of sudden and unexpected power OFF, the instrument panel displays the default settings for Menu 1 and Menu 2 upon the following KEY-ON; in particular:

- Menu 1 default page = Odometer;
- Menu 2 default page (Core and Full modes only) = Average fuel consumption.

Upon KEY-ON, for every display layout, instrument panel shows for 10 seconds in Menu 1 the "Odometer" page and then shows the page saved upon previous KEY-OFF.

When the standard screen of set layout is displayed, hold button (2) for 3 seconds, when actual motorcycle speed is \leq (lower than or equal to) 20 km/h (12 mph), to enter the Setting menu, where you can set any function.

You can enter the SETTING MENU only if vehicle actual speed is \leq (lower than or equal to) 5 km/h (3 mph). Within the SETTING MENU, if vehicle actual speed exceeds 5 km/h (3 mph), the instrument panel automatically quits the menu and shows the Standard Screen.

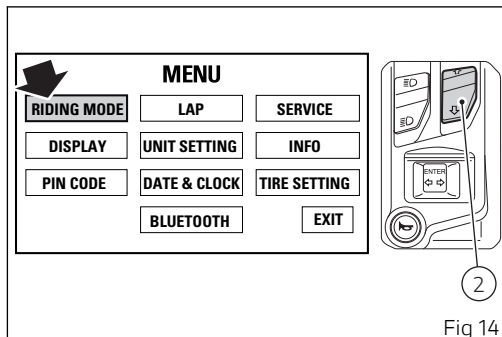

If the key is not acknowledged upon Key-ON and once the check routine is over, the following will happen:

- if the PIN CODE function is not active, the instrument panel skips the warning light check, displays the standard screen with an E-LOCK error warning and does not allow accessing the Setting Menu;
- if the PIN CODE function is active, the PIN CODE function page is displayed on the instrument panel, allowing rider to enter the release code.

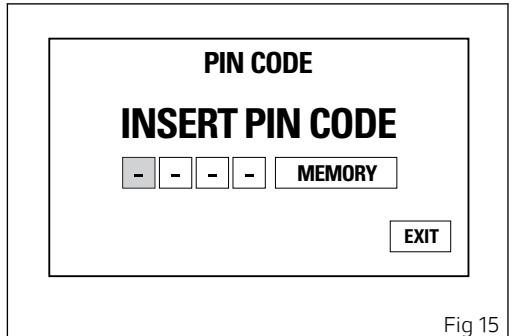

Fig 15

Main functions

Information displayed in the standard screen of the selected display layout (CORE, FULL or TRACK) are the following:

Main information

- Engine rpm indication (RPM)
- Motorcycle speed
- Gear indication
- Fuel level
- Riding Mode
- DTC
- ABS
- the menus display the following functions:
 - Odometer (TOT)
 - Trip meter 1 (TRIP1)
 - Trip meter 2 (TRIP2)
 - Residual range (RANGE)
 - LAP time
 - Engine Coolant temperature
 - Instantaneous fuel consumption (CONS.)
 - Average Fuel Consumption (CONS. AVG)
 - Average speed (SPEED AVG)
 - Trip time (TRIP TIME)
 - Ambient air temperature
 - Clock

Additional information

- Infotainment (presetting)
- LAP
- Service indication (SERVICE)
- Warnings/Alarms
- "ERROR" indication
- Viewing side stand status

The functions within the Setting Menu that can be modified by the user are the following:

- Riding mode customisation (RIDING MODE):
this menu allows customisation of:
 - ABS setting (ABS)
 - DTC level setting (DTC)
 - Engine setting (ENGINE)
 - Reset to default settings (DEFAULT)
- Display: this menu allows the following settings:
 - Display mode setting
 - Display backlighting (BACK LIGHT)
- PIN CODE (enter/change)
- LAP (view/delete/reset automatic settings)
- Unit setting: Speed - Temperature - Fuel consumption
- Date and time setting (DATE & CLOCK)
- Bluetooth device setting (BLUETOOTH)
- Threshold information of the Service function (SERVICE): Oil Service - Desmo Service - Annual Service
- Info (INFO): Battery - RPM - Bluetooth version
- Tyre setting and drive ratio (TIRE SETTING)

Engine rpm indication (RPM)

The instrument panel receives the engine rpm information and displays it on the relevant bargraph (in FULL and TRACK display modes only). The information is displayed by the bargraph filling from the left to the right according to the engine rpm and with the enlargement of the numerical digit of the relevant miles (if the RPM value is "8000" or higher, number "8" is displayed bigger).

When reaching 12000 rpm no numerical digit is "zoomed": number "12" is not displayed in a bigger size and returns to the standard size of number "11").

The range between 9500 and 10500 rpm (pre-warning area) is displayed in orange both for the bargraph filling and for the indication of value "10" (orange area).

The range between 10500 and 11000 rpm (warning area) is displayed in red both for the bargraph filling and for the indication of value "11" (red area).



Important

During the first 1000 km (600 mi) (Running-in period), i.e. when the Odometer displays a value \leq (lower than or equal to) 1000 km (600 mi), the pre-warning area, indicated in orange (Orange area), both for the bargraph filling and the display of the relevant number, is displayed when reaching 6000 rpm. During the running-in period we recommend not to exceed 6000 rpm, thus the instrument panel will not display the bargraph "Orange area".

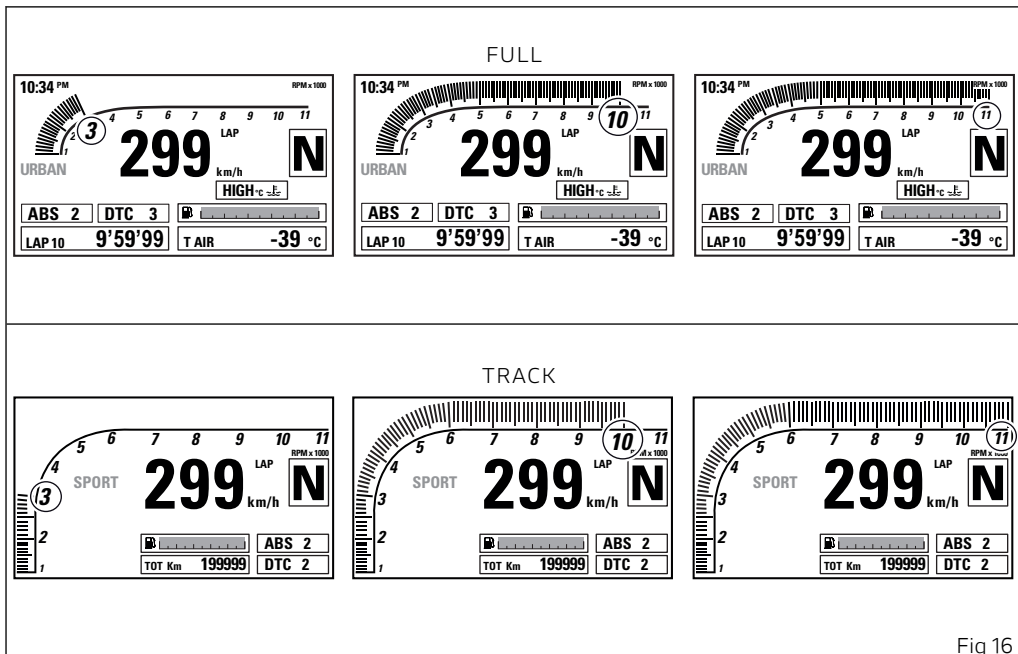

Fig 16

After the running-in period, the "orange area" displays the message that prompts to ride the bike at lower rpm when the engine is cold. The "orange area" changes according to the engine temperature, as indicated below:

- from 7000 rpm and engine temperature of 50 °C (122 °F) or lower;
- from 9500 rpm and engine temperature higher than 50 °C (122 °F);

The rpm limiter intervention threshold is equal to 9750 rpm.

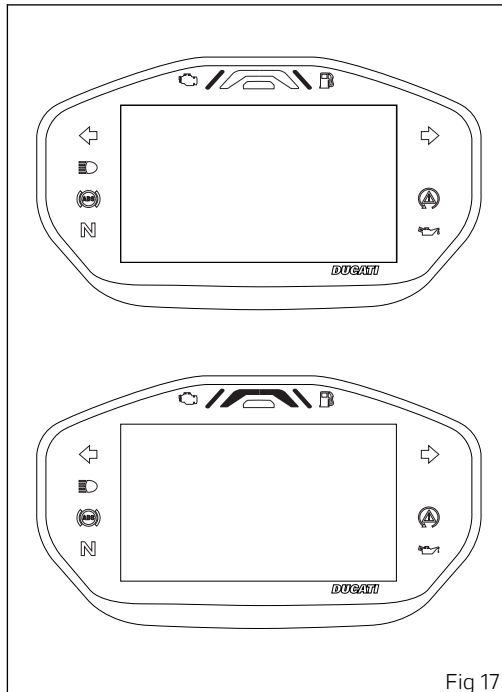

Fig 17

Motorcycle speed

The instrument panel receives information about the actual motorcycle speed (calculated in km/h) and displays the value increased by 5% and converted in the set unit of measurement (km/h or mph).

A string of dashes "- - -" is displayed with the set unit of measurement if:

- speed is equal to 299 km/h or 186 mph or if instrument panel is not receiving the speed value ("- - -" steady ON);
- the rear speed sensor is in fault (flashing "- - -").

The following page shows the function in TRACK layout. For CORE and FULL layouts, values for these functions are indicated in the same way as for the TRACK mode.

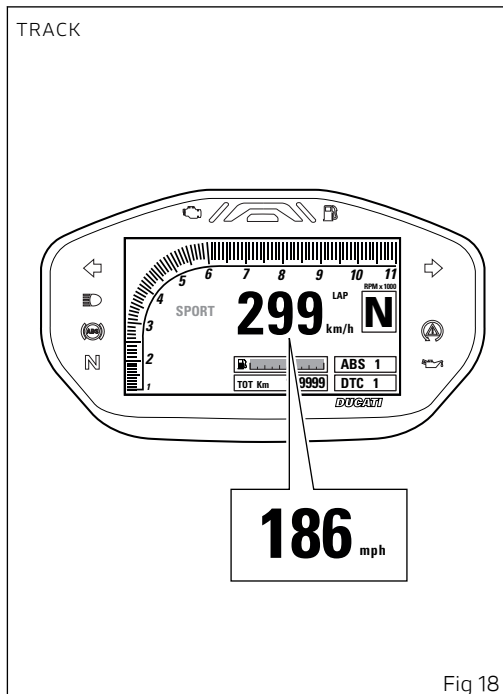

Fig 18

Gear

The instrument panel receives information about the gear engaged and displays the corresponding value.

If a gear is engaged, the displayed value may range from 1 to 6, while if in neutral N is displayed.

Letter "C" and NEUTRAL warning light flash on the instrument panel if the gear teach-in procedure has not been performed yet.

"-" is displayed if:

- the gear sensor is in fault ("-" steady on and NEUTRAL warning light flashing);
- the instrument panel is not receiving the gear data ("-" flashing).

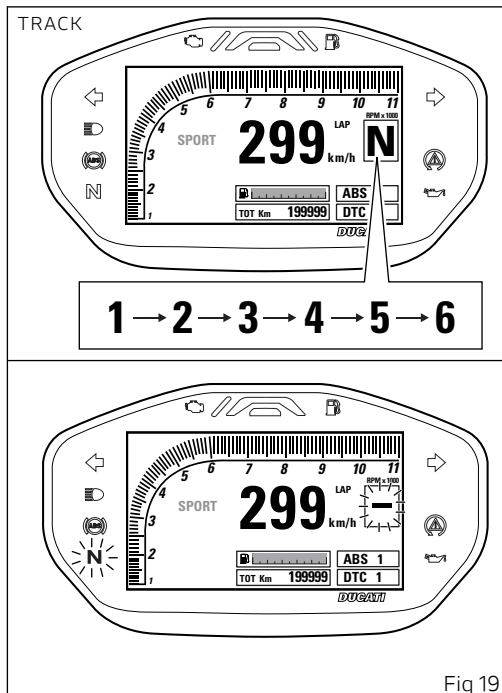

Fig 19

Riding Mode (RIDING MODE)

The Riding Mode can be selected from the instrument panel. Three preset riding modes are available: SPORT, TOURING and URBAN.

The selected and active riding mode is displayed on the bottom part of the instrument panel display, in CORE layout, or next to speed indication in FULL and TRACK layouts.

Every Riding Mode contains the following parameters, set by Ducati or customised by the user through the setting function pages:

- a specific ABS calibration (1, 2, 3);
- a specific level of intervention for the DTC traction control (1, 2, 3, 4, 5, 6, 7, 8, OFF);
- a specific engine power that will change throttle behaviour (MAP1, MAP2, MAP3);

A different standard screen (CORE, FULL and TRACK) is associated to every riding mode; it is set by Ducati or customised by the user from the setting pages.



Attention

Ducati recommends changing the Riding mode when the motorcycle is stopped. If the riding mode is changed while riding, be very careful (it is recommended to change the Riding mode at a low speed).

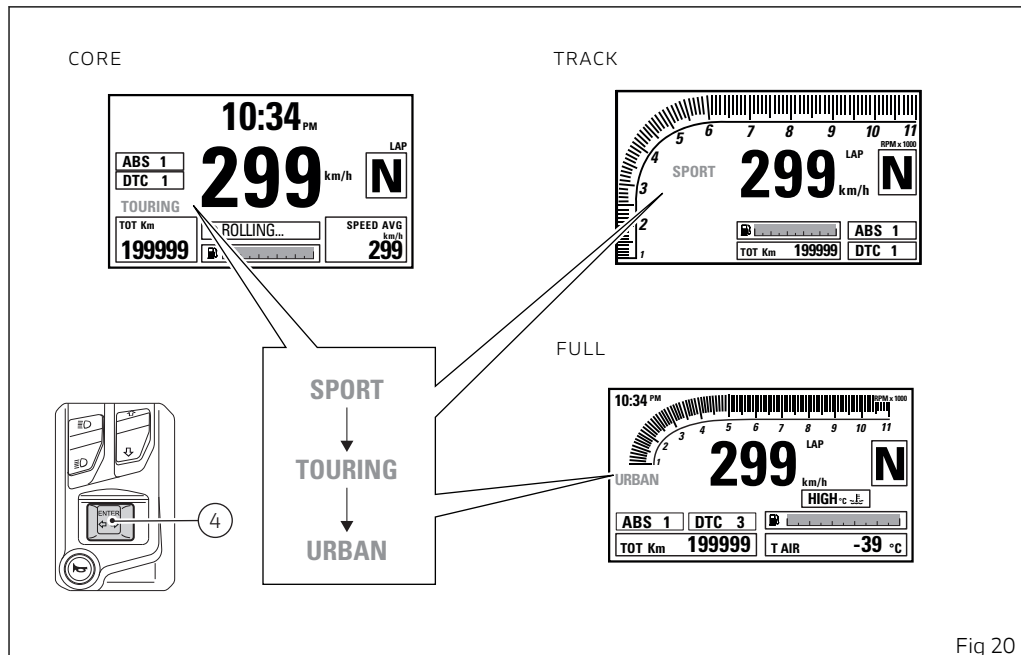

Fig 20

Selecting the Riding Mode

Press CONFIRM MENU button (4) to enter the menu for selecting the Riding Mode (A). The instrument panel displays the speed indication (on the RH side) and displays riding mode name (on the LH side):

- SPORT
- TOURING
- URBAN

One of them will be marked to indicate the last memorised condition that is currently active.



Attention

It is not possible to open the menu for selecting the riding mode, if button (4) is in the position for activating the turn indicators (to the left or right)

For the marked Riding Mode, instrument panel displays information concerning some of the associated parameters:

- ABS system: the ABS text followed by the level of calibration set (1, 2, 3).
- DTC system: DTC lettering followed by the set level (1, 2, 3, 4, 5, 6, 7, 8) in case DTC is active or followed by OFF in case DTC is disabled;
- engine power (ENGINE): ENG lettering followed by set engine power: HIGH, MED or LOW.

Displayed information includes the values stored for each single Riding Mode. The stored settings may be the factory ones (Ducati default settings) or the ones customised by the owner. Any time CONFIRM MENU button (4) is pressed, the selected riding mode is highlighted together with the associated parameters.

Once the desired riding mode is highlighted, confirm the selection by holding down the CONFIRM MENU button (4) for 2 seconds: the new riding mode selection is stored and the standard screen is displayed.

Once the desired riding mode is highlighted, if the CONFIRM MENU button (4) is not pressed within 5 seconds, the new riding mode selection is not stored and the Standard screen is displayed.

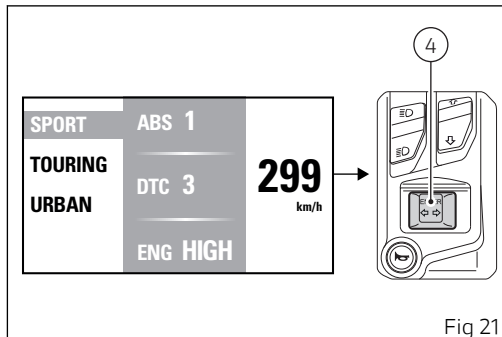

When system requests rider to confirm the riding mode change, the procedure will output an error if:

- the throttle twistgrip is open, brakes are activated and the motorcycle is not still; in this case "CLOSE THROTTLE AND RELEASE BRAKES" warning is displayed. If throttle is not closed or brakes are not released or vehicle is not taken to zero speed within 5 seconds, the riding mode change procedure will not be completed and the display will go back to standard screen.

Note

If the change of riding mode is associated with the ABS change of state from "ON" to "OFF" or vice-versa, the instrument panel also starts the procedure for disabling or activating the ABS, respectively, upon confirmation of the selected riding mode.

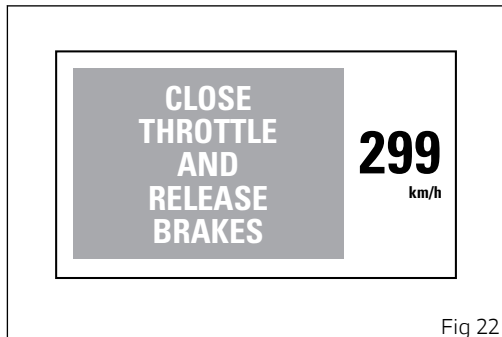

Fig 22

DTC

The instrument panel displays DTC status as follows:

- if DTC is active, DTC lettering and the Traction Control intervention level number (1 to 8);
- If DTC is not active, DTC OFF lettering and the DTC Status warning light on display turns on;
- if DTC or the Black Box is in fault, the indication DTC Err in red and the DTC status warning light on the instrument panel will turn on.

The function is displayed with TRACK layout. For CORE and FULL layouts, values for these functions are indicated in the same way as for the TRACK mode.

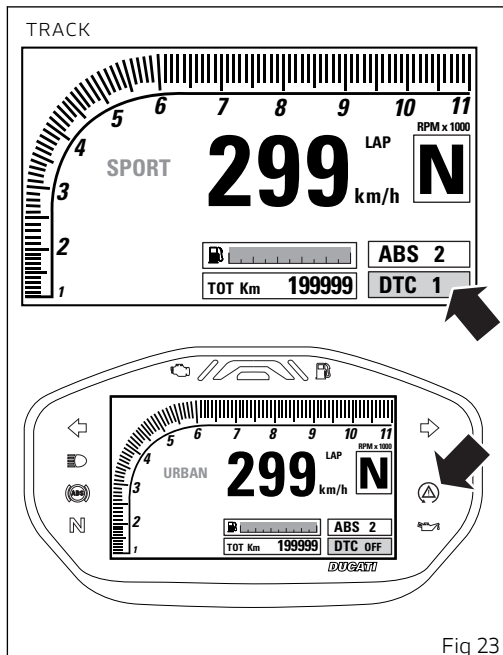

Fig 23



Attention

The DTC is a rider assist system. The system is designed to make riding easier and to enhance safety, but in no way relieves the rider of the obligation to drive responsibly and to maintain a high standard of riding in order to avoid accidents, whether caused by his own errors or those of other road users, through making emergency manoeuvres, in accordance with the prescriptions of the road traffic code.

The rider must always be aware that active safety systems have a preventive function. The active elements help the rider control the motorcycle, making it as easy and safe to ride as possible. The presence of an active safety system should not encourage the rider to ride at speeds beyond the reasonable limits, not in accordance with the road conditions, the laws of physics, good riding standards and the requirements of the road traffic code.

The following table indicates the most suitable level of DTC intervention for the various riding modes as well as the default settings in the "Riding Modes" that can be selected by the rider.

DTC	RIDING MODE	USE	DEFAULT
1	SPORT	Sports style for very expert riders. System permits sliding sideways.	NO
2	SPORT	Sports style for expert riders. System permits sliding sideways.	NO
3	SPORT	Sports style for medium-expert riders. System permits sliding sideways.	It is the default level for the "SPORT" Riding Mode
4	TOURING	Fast touring style.	It is the default level for the "TOURING" Riding Mode
5	TOURING	Touring style.	NO
6	URBAN	"Very safe" style on any kind of path.	It is the default level for the "URBAN" Riding Mode
7	RAIN	For riding on slightly wet or moist road. ENGINE LOW setting recommended.	NO
8	HEAVY RAIN	For riding on wet road. ENGINE LOW setting recommended.	NO

Tips on how to select the sensitivity level



Attention

All levels of the DTC system of your vehicle have been calibrated with original equipment tyres (Pirelli Diablo Rosso III 120/70 - 17 front and Pirelli Diablo Rosso III 180/55 - 17 rear). The use of tyres of different size and characteristics to the original tyres may alter the operating characteristics of the system.

In the case of minor differences, such as for example, tyres of a different make and/or model than the OE ones, but with the same size (front = 120/70 - 17, rear = 180/55 - 17), it may be sufficient to simply select the suitable level setting from those available in order to restore optimal system operation. If tyres of a different size class are used or if the tyre size differs significantly from the original tyres, it may be that the system operation is affected to the point where none of the 8 available level settings will give satisfactory results. In this case it is advisable to deactivate the traction control system.

If level 8 is selected, the DTC system will kick in at the slightest hint that the rear wheel is starting to spin.

Between level 8 and level 1 there are intermediate levels. DTC intervention decreases from level 8 to level 1. Levels 1, 2 and 3 allow both spinning and skidding of the rear wheel out of a corner: these levels are recommended only for expert riders.

The choice of the correct level mainly depends on the following parameters:

- 1) The tyre/asphalt grip (type of tyre, amount of tyre wear, the road/track surface, weather conditions, etc.);
- 2) The characteristics of the path/circuit (bends all taken at similar speeds or at very different speeds);
- 3) The riding mode (whether the rider has a "smooth" or a "rough" style).

Level depends on grip conditions

The choice of level setting depends greatly on the grip conditions of the track/path (see below, tips for use on the road).

Level depends on type of track/path

If the track/path features bends all taken at similar speeds, it will be easier to find a level suitable for all

bends; while a track/path with bends all requiring different speeds will require a DTC level setting that is the best compromise for all bends.

Level depends on riding style

The DTC will tend to kick in more with a "smooth" riding style, where the motorcycle is leaned over further, rather than with a "rough" style, where the motorcycle is straightened up as quickly as possible when exiting a turn.

Tips for use on dry road

Activate the DTC, select level 6 and ride the motorcycle in your usual style; if the level of DTC sensitivity seems excessive, try levels 5, 4, etc., until you find the one that suits you best.

If changes occur in the grip conditions and/or circuit characteristics and/or your riding style, and the level setting is no longer suitable, switch to the next level up or down and proceed to determine the best setting (e.g. if with level 5 the DTC intervention seems excessive, switch to level 4; alternatively, if on level 5 you cannot perceive any DTC intervention, switch to level 6).

Tips for use on wet road

Level 7 is recommended when road is slightly wet or damp and level 8 on wet road. It is also recommended to select ENGINE LOW in these conditions.

ABS

The motorcycle is equipped with ABS and the instrument panel displays ABS status.

The instrument panel displays:

- if the ABS is active, the message "ABS" with the set intervention level number (1 to 3);
- if ABS is in fault or instrument panel is not receiving information from the ABS; the ABS Err lettering in red and the ABS warning light ON.

The function is displayed with TRACK layout. For CORE and FULL layouts, values for these functions are indicated in the same way as for the TRACK mode.

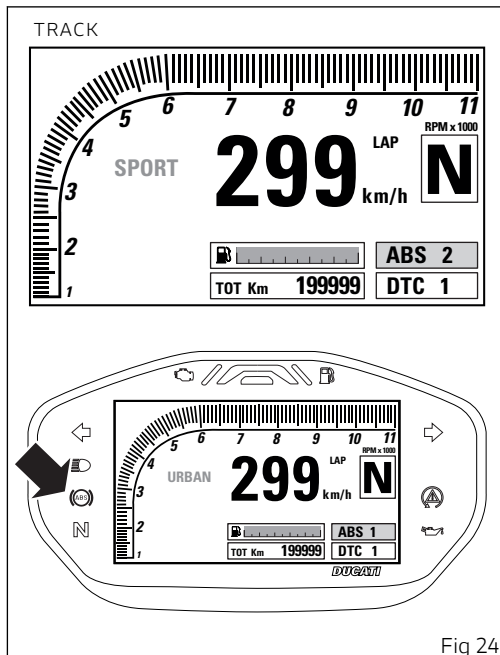

Fig 24

Using the brakes correctly under adverse conditions is the hardest – and yet the most critical – skill to master for a rider. Braking is one of the most difficult and dangerous moments when riding a two wheeled motorcycle: the possibility of falling or having an accident during this difficult moment is statistically higher than any other moment. A locked front wheel leads to loss of traction and stability, resulting in loss of control.

The Anti-Lock Braking System (ABS) has been developed to enable riders to use the motorcycle braking force to the fullest possible amount in emergency braking or under poor pavement or adverse weather conditions. ABS is an electro-hydraulic device that controls the pressure in the brake circuit when the control unit, by processing information from wheel sensors, determines that one or both wheels are about to lock up. In this case, pressure decrease in the brake circuit allows the wheel to carry on turning, thereby preserving grip. After that, the control unit restores the pressure in the brake circuit, to resume the braking action. This cycle is repeated many times until the problem is completely eliminated. Normally, the rider will perceive ABS operation as a harder feel or a

pulsation of the brake lever and pedal. The front and rear brakes use separate control systems.



Attention

Using the two brake controls separately reduces the motorcycle braking power.

Never use the front brake control harshly or suddenly as you may cause rear wheel lift-up and lose control of the motorcycle (if the ABS is enabled). When riding in the rain or on slippery surfaces, braking will become less effective. Always use the brakes very gently and carefully when riding under these conditions. Any sudden manoeuvres may lead to loss of control.

When tackling long, high-gradient downhill road tracts, shift down gears to use engine braking. Apply one brake at a time and use brakes sparingly. Keeping the brakes applied all the time would cause the friction material to overheat as well as a possible generation of vapour lock (brake fluid boiling) with a considerable reduction of the braking power. Underinflated and overinflated tyres reduce braking efficiency, handling accuracy and stability in a bend.

The following table indicates the most suitable level of ABS intervention for the various riding types as well as the default settings in the "Riding Mode" that can be selected by the rider:

ABS	RIDING MODE	CHARACTERISTIC	DEFAULT
1	TRACK/SPORT	Typical use conditions: road or track use, in excellent grip conditions. The ABS in this mode controls both wheels, but NO anti lift-up* control is active. This calibration focuses on braking power.	It is the default level for the "SPORT" Riding Mode
2	SPORT/TOURING	Typical use conditions: road use, in excellent grip conditions. The ABS in this mode controls both wheels and anti lift-up* controls are active. This calibration focusses on braking power and yet keeps good stability under braking and lift-up* control.	It is the default level for the "TOURING" Riding Mode
3	ALL/URBAN/WET CONDITION	Typical use conditions: any riding condition. The ABS in this mode controls both wheels and anti lift-up* controls are active. This calibration focusses on maximum vehicle stability and lift-up* prevention, yet keeping good maximum deceleration performance.	It is the default level for the "URBAN" Riding Mode

* rear wheel lifting up upon maximum deceleration

Tips on how to select the sensitivity level



Attention

The levels of the ABS system your motorcycle is equipped with were calibrated with original equipment tyres. The use of tyres of different size and characteristics to the original tyres may alter the operating characteristics of the system thus making it unsafe. It is recommended not to install tyres of different size than the ones approved for your vehicle.

Motorcycle original equipment:
(front 120/70ZR17 - rear 180/55ZR17).
- Pirelli Diablo Rosso III;

The use of tyres of different size and characteristics to the original tyres may alter the operating characteristics of the system thus making it unsafe. It is recommended not to install tyres of different size than the ones approved for your vehicle.

Selecting level 3, the ABS will intervene to ensure a very stable braking, good lift-up control, the motorcycle keeps a good alignment during the whole braking.

Settings between level 3 and level 1 privilege more and more the braking power rather than stability and lift-up control; level 1 provides no lift-up control.

The choice of the correct level mainly depends on the following parameters:

- 1) The tyre/asphalt grip (type of tyre, amount of tyre wear, the road/track surface, weather conditions, etc.).
- 2) The rider's experience and sensitivity: expert riders can tackle a lift-up in trying to reduce the stopping distance to a minimum, while less expert riders are recommended to use settings 2 and 3, that will help them keeping the motorcycle more stable even in emergency braking.

Menu functions

For each of the three riding modes (SPORT, TOURING and URBAN) menu functions can be displayed in one of the following three layouts or modes:

- CORE;
- FULL;
- TRACK.

Available functions are:

- Odometer (TOT);
- Trip meter 1 (TRIP1);
- Trip meter 2 (TRIP2);
- Residual range (RANGE);
- LAP time (if active);
- Coolant temperature;
- Instantaneous fuel consumption;
- Average fuel consumption;
- Average speed;
- Trip time;
- Ambient air temperature;
- Clock.

CORE and FULL modes display them in menu (A) on the left and in menu (B) on the right. TRACK mode displays them only in menu (C).

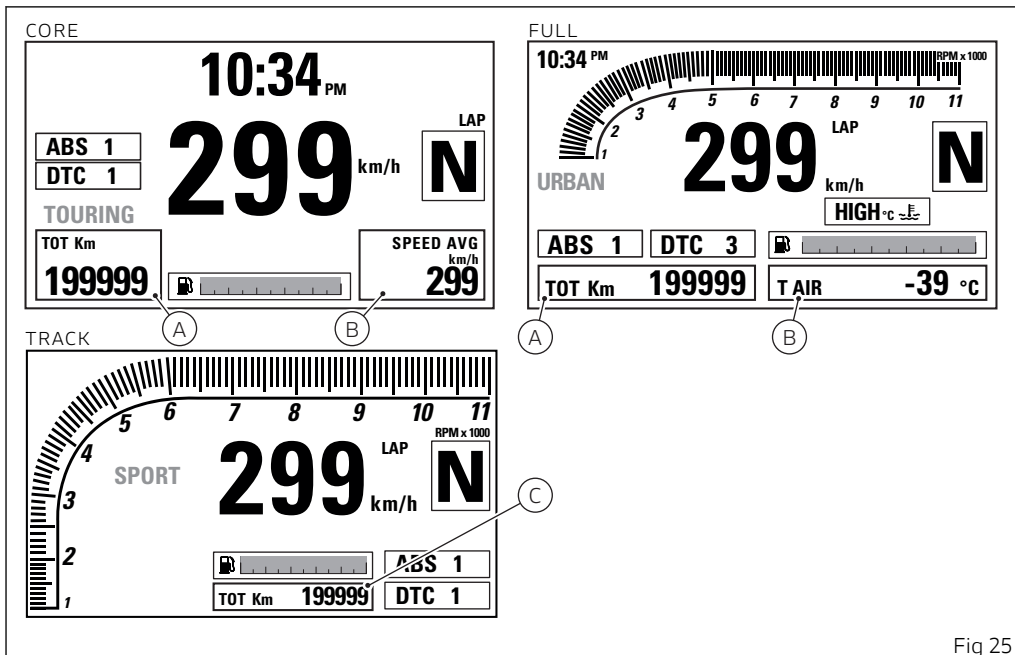

Fig 25

Odometer (TOT)

The odometer counts and displays the total distance covered by the motorcycle with the set unit of measurement (km or mi).

The odometer number (in km or miles) is displayed with the message TOT and the indication of the unit of measurement. When the maximum value is reached (199999 km or 199999 mi) the instrument panel will permanently display said value.

The odometer value is saved permanently and cannot be reset under any circumstances.

The reading is not lost in case of a power OFF (Battery OFF).

The function is displayed with TRACK layout. For CORE and FULL display modes, the value for this function is indicated in the menu at the bottom left-hand side.

Note

Upon Key-ON, the instrument panel always shows the Odometer indication for 10 seconds, then shows the user's settings page.

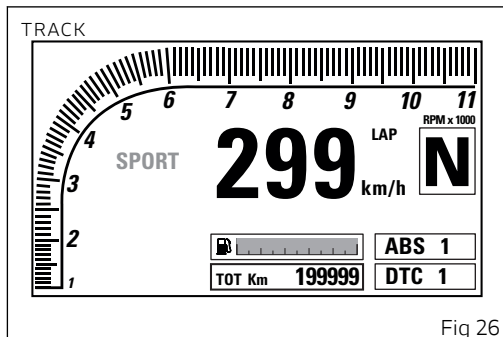

Fig 26



Note

If a string of flashing dashes " ---- " is displayed within odometer function, please contact a Ducati Dealer or Authorised Service Centre.

Trip meter 1 (TRIP 1)

The trip meter counts and displays the partial distance covered by the motorcycle with the set unit of measurement (km or mi) and is used as a basis to calculate average fuel consumption, average speed and trip time. The TRIP1 number (in km or miles) is displayed with the message TRIP1 and the indication of the unit of measurement.

When the reading exceeds the maximum value of 9999.9 km or 9999.9 mi, distance travelled is reset and the meter automatically starts counting from 0 again.

While the trip meter is displayed, press button (1) for 2 seconds to reset TRIP 1. When TRIP1 is reset, the average fuel consumption, average speed and trip time data are reset as well.

The TRIP1 counter is automatically reset in case the system unit of measurement is changed manually: the counter will then start back from zero, considering the new units of measurement.

The function is displayed with TRACK layout. For CORE and FULL display modes, the value for this function is indicated in the menu at the bottom left-hand side.

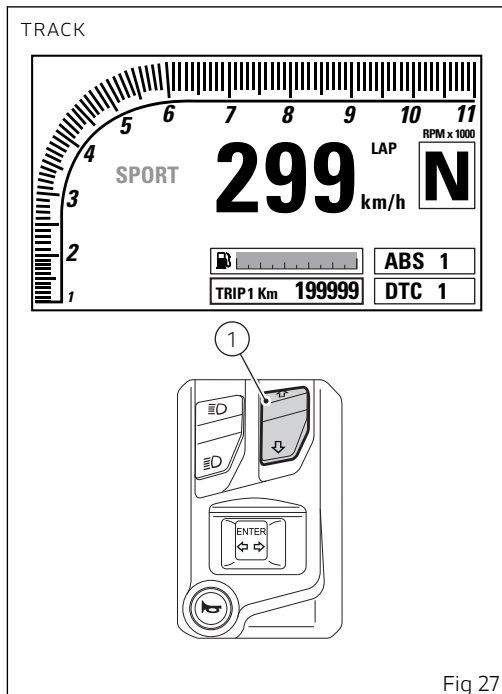

Fig 27

Trip meter 2 (TRIP 2)

The trip meter counts and displays the partial distance covered by the motorcycle with the set unit of measurement (km or mi).

The TRIP2 number (in km or miles) is displayed with the message TRIP2 and the indication of the unit of measurement.

When the reading exceeds the maximum value of 9999.9 km or 9999.9 mi, distance travelled is reset and the meter automatically starts counting from 0 again.

While the trip meter is displayed, press button (1) for 2 seconds to reset TRIP 2.

The TRIP2 counter is automatically reset in case the system unit of measurement is changed manually: the counter will then start back from zero, considering the new units of measurement.

The function is displayed with TRACK layout. For CORE and FULL display modes, the value for this function is indicated in the menu at the bottom left-hand side.

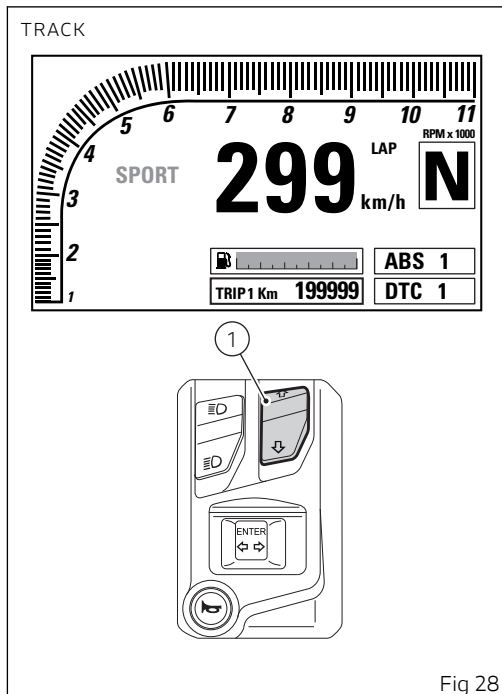

Fig 28

Residual range (RANGE)

This function displays the range according to the remaining fuel in the tank.

Information is indicated as RANGE, in the set unit of measurement.

If there is any function fault, the instrument panel will display three flashing dashes " - - -".

If the instrument panel is not receiving RANGE information, a string of three steady dashes " - - -" is displayed, followed by the unit of measurement.



Note

If the instrument panel does not receive any information on the unit of measurement, the last unit of measurement set is displayed flashing.

Considering that the TRACK and FULL layouts show the values for this function in a similar way to the CORE layout, the example shown depicts the function in CORE layout.

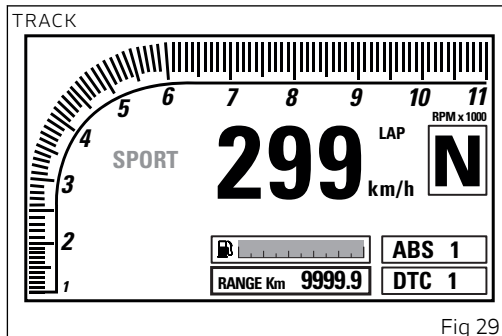

Fig 29

LAP TIME

The LAP function is available for the CORE and FULL display modes on the LH menu, while for the TRACK display mode it is in the central menu.

LAP function information is available when the function is active.

When the LAP function is active, upon the first press on FLASH button (3) menu displays LAP 01 message and START flashing for 4 seconds and then the time measured with a resolution of one tenth of a second (" 0'00'0 ") for another 2 seconds. Upon any further press of the FLASH button (3), the just ended lap number and time are displayed with a resolution of one hundredth of a second (" 0'00'00") for 6 seconds and then lap timer is displayed again together with the number of new current lap (if LAP function is selected from the menu).

If the LAP function is not selected from the menu, the instrument panel will go back to the functions present before the FLASH button (3) was pressed. It is possible to scroll the other menu functions at any time.

When storing the 30th LAP, the LAP function is stopped and upon any further press on the FLASH button (3), the instrument panel will display flashing

FULL message warning that the storage space for lap times is full.

The function is displayed with TRACK layout. For CORE and FULL display modes, the value for this function is indicated in the menu at the bottom left-hand side.

TRACK

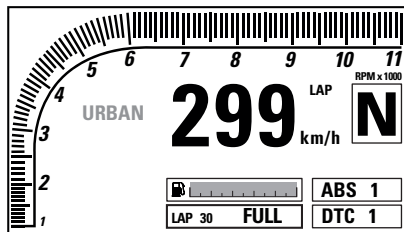
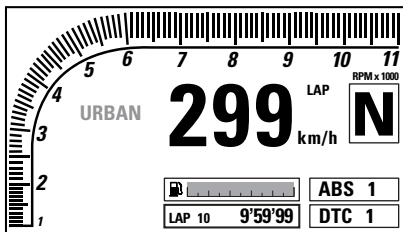
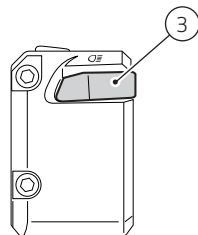
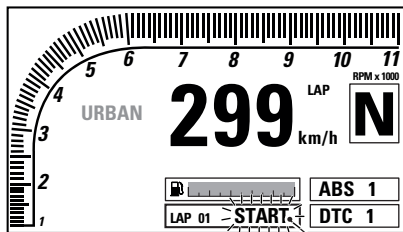

Fig 30



Note

When the LAP function is active, the FLASH button takes on the dual function of high beam "FLASH" and LAP timer finish line storage control (new lap start indication).



Note

The TRIP FUEL function always has top priority over the LAP function: in case of activation of the TRIP FUEL function with active LAP function, the LAP timer view is automatically removed and TRIP FUEL information is displayed instead.

LAP recording

If the LAP function is active, it is possible to record the lap time, for a total of 30 consecutive laps.

Operation:

- any further time the motorcycle goes through the finish line, the just ended lap number and time are displayed for 5 seconds with a resolution of one hundredth of a second;
- after these 5 seconds, the instrument panel goes back to lap timer page referred to the new current lap.

- on the 30th lap, when the FLASH button (3) is pressed, and every time it is pressed, current lap is stored and the message FULL is displayed to indicate that available storage space is full.

If the time is never stopped, it will roll over upon reaching 9 minutes, 59 seconds and 99 hundredths; the lap timer starts counting from zero and will keep running until the lap is stopped or the recording function is disabled.

During every lap, the following data are stored:

- no. 30 lap times (time between consecutive start and stop);
- no. 30 values for max. RPM (maximum RPM value reached in every lap);
- no. 30 values for max. speed (maximum speed value reached in every lap).

Engine Coolant temperature

The instrument panel receives information about the engine temperature (already calculated in °C) and displays the value in the set unit of measurement (°C or °F), followed by the unit of measurement and the engine temperature symbol. The temperature display range goes from 40 °C to +120 °C (+104 °F ÷ +248 °F).

If reading is:

- ≤ (lower than or equal to) -40 °C (-40 °F), a string of flashing dashes " - - - " is displayed;
- within the range -39 °C (-38 °F) to +39 °C (+102 °F), "LOW" is displayed steadily;
- within the range +40 °C (+104 °F) to +120 °C (+248 °F), the value is displayed steadily;
- ≥ (higher than or equal to) +121 °C (+250 °F), "HIGH" is displayed flashing.

If engine coolant temperature exceeds:

- 100 °C (+212 °F), temperature value is immediately displayed in the menu, regardless of any other function displayed in the menu; it is still possible to view the other menu functions;

- 121 °C (+250 °F), temperature value is immediately displayed in the menu, regardless of any other function displayed in the menu; it is not possible to view the other menu functions. The alarm icon is also displayed.

If the coolant temperature sensor is in fault, a string of flashing dashes " - - - " is displayed, followed by the set unit of measurement; the EOBD light turns on as well.

If the instrument panel is not receiving coolant temperature value, a string of steady dashes " - - - " is displayed, followed by the unit of measurement.

CORE

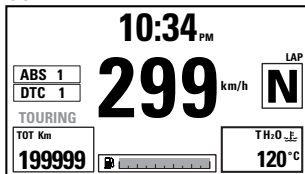

FULL

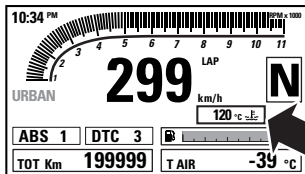

TRACK

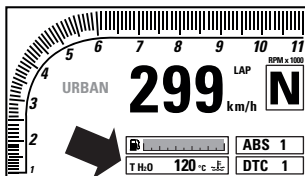

TRACK

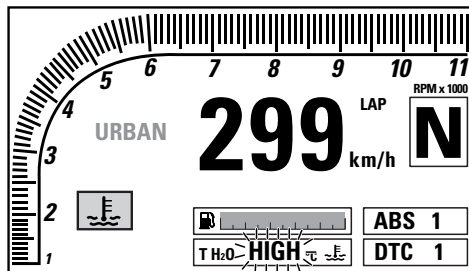

Fig 31

Instantaneous fuel consumption

The instrument panel calculates and displays the motorcycle instantaneous fuel consumption, the set unit of measurement and CONS.I. text.

The calculation is made considering the quantity of fuel used and the distance travelled during the last second. Value is expressed in the set unit of measurement: litres / 100 km or mpg UK or mpg USA.

The active calculation phase only occurs when the engine is running and the motorcycle is moving (moments when the motorcycle is not moving when speed is equal to 0 and/or when the engine is OFF are not considered). When the calculation is not made, a string of three dashes is displayed " - - - " steadily as instantaneous fuel consumption.

Note

It is possible to change the units of measurement of Speed (and distance travelled as well) from km/h (and km) to mph (and mi) through the SETTING MENU, using the UNITS SETTING function.

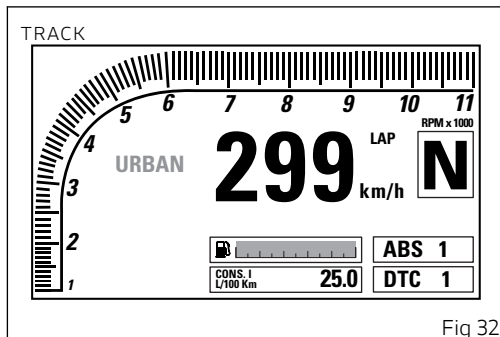

Fig 32

Average fuel consumption

The instrument panel calculates and displays the motorcycle average fuel consumption, the set unit of measurement and CONS. AVG.

The calculation is made considering the quantity of fuel used and the distance travelled since TRIP1 was last reset.

When TRIP1 is reset, the value is reset and the first value available is displayed 10 seconds after the reset.

During the first 10 seconds, when the value is not yet available, the display will show a string of three dashes "- - -" steadily as average fuel consumption.

Value is expressed in the set unit of measurement (litres / 100 km or mpg UK or mpg USA).

The active calculation phase occurs when the engine is running and the motorcycle is stopped: (moments when the motorcycle is not moving and the engine is OFF are not considered).

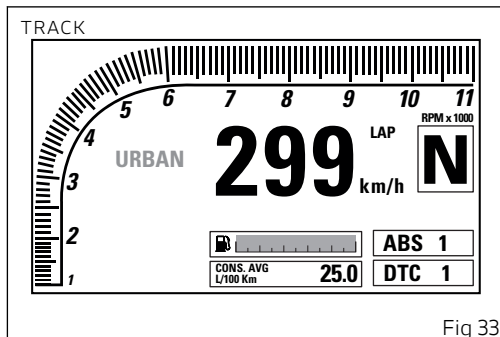

Fig 33



Note

It is possible to change the units of measurement of Speed (and distance travelled as well) from km/h (and km) to mph (and mi) through the SETTING MENU, using the UNITS SETTING function.

Average speed

The instrument panel calculates and displays the motorcycle average speed, the set unit of measurement and SPEED AVG text.

The calculation considers the distance and time since TRIP1 was last reset.

When TRIP1 is reset, the value is reset and the first value available is displayed 10 seconds after the reset.

During the first 10 seconds, when the value is not yet available, the display will show a string of three dashes " - - - " steadily as average speed.

The active calculation phase occurs when the engine is running even if the motorcycle is stopped (moments when the motorcycle is not moving and the engine is OFF are not considered).

The average speed value displayed is calculated by adding 5% so as to be consistent with motorcycle speed indication.

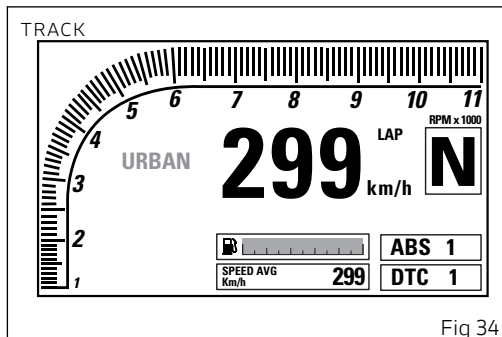

Fig 34



Note

It is possible to change the units of measurement of Speed (and distance travelled as well) from km/h (and km) to mph (and mi) through the SETTING MENU, using the UNITS SETTING function.

Trip time

The instrument panel calculates and displays the trip time as hhh:mm followed by TRIP TIME. The calculation considers the time since TRIP1 was last reset. When TRIP1 is reset, this value is reset as well. The time count active phase occurs when the engine is running and the motorcycle is stopped (the time is automatically stopped when the motorcycle is not moving and the engine is OFF and restarts when the counting active phase starts again). When the reading exceeds 511:00 (511 hours and 00 minutes), the meter is reset and automatically starts counting from 0 again.

Note

If you change the unit of measurement for an item connected to Speed (and distance) or Consumption, the trip time value will be automatically reset.

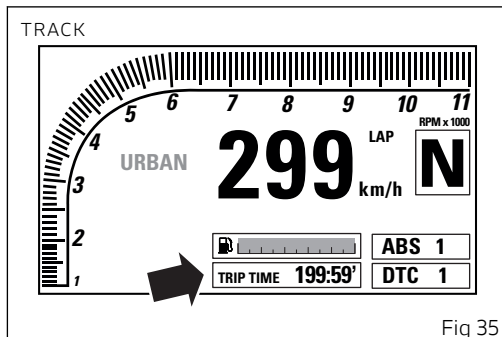

Fig 35

Ambient air temperature

The instrument panel displays the ambient temperature in the set unit of measurement (°C or °F), followed by the set unit of measurement, the message AIR and the thermometer symbol. The temperature value is displayed when ranging from -39 °C to +124 °C (or -38 °F ÷ +255 °F). For any different temperature (below -39 °C (-38 °F) or above +124 °C (+255 °F)) a string of three dashes " - - - " is steadily displayed, followed by the unit of measurement.

If the air temperature sensor is in fault, the instrument panel will show three flashing dashes " - - - " as air temperature value, followed by the unit of measurement and the Generic Error light will be displayed. If the instrument panel is not receiving air temperature value, a string of three steady dashes " - - - " is displayed, followed by the unit of measurement.



Note

When the motorcycle is stopped, the engine heat could influence the displayed temperature.

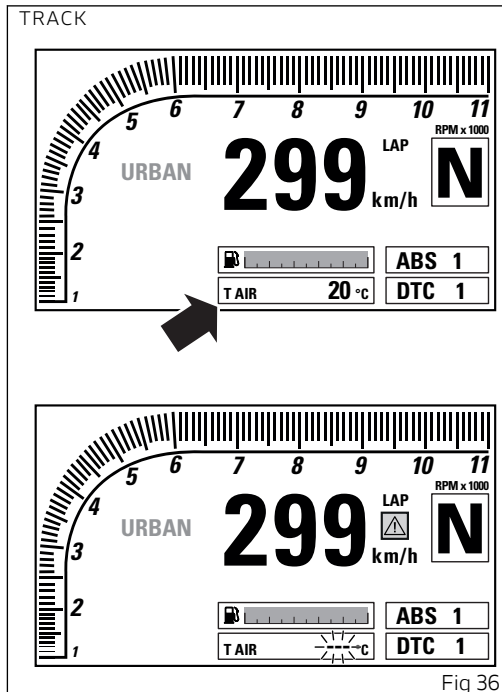

Fig 36

Clock

The instrument panel receives information about the time to be displayed.

The time indication is displayed in different ways depending on the display mode in use (CORE, FULL or TRACK).

The instrument panel shows the time in the following format:

- hh (hours) : mm (minutes);
- followed by a.m. (from 01:00 to 11:59) or p.m. (from 12:00 to 12:59 and from 1:00 to 11:59).

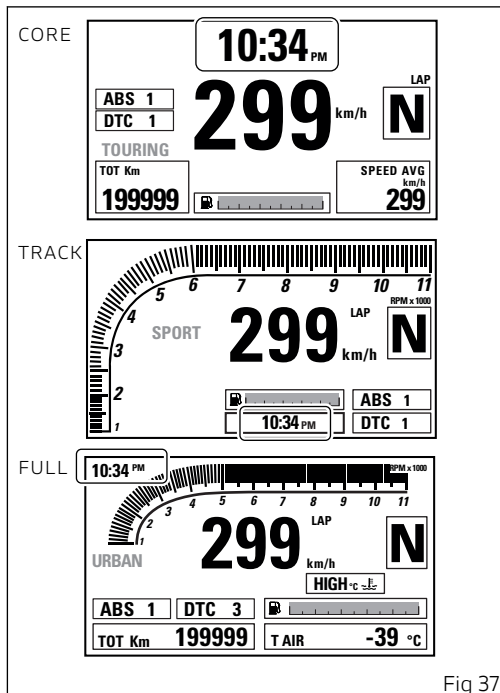

Fig 37

Auxiliary functions

LAP

The instrument panel displays the LAP function status (LAP recording on or off).

"LAP" message is on if LAP is ON (i.e. timer recording) or off if LAP is OFF.

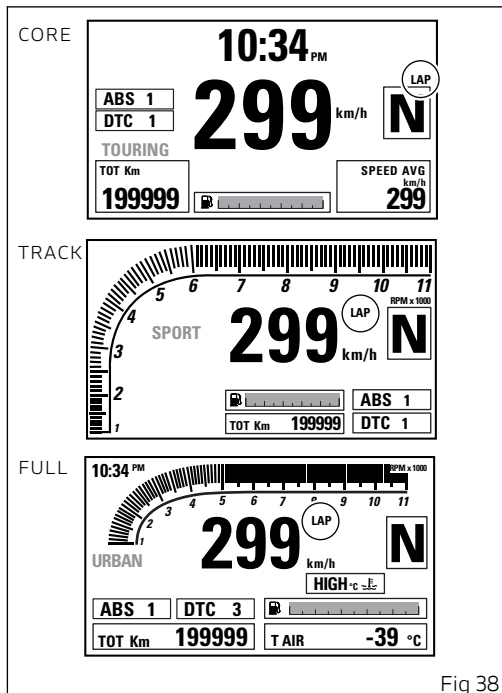

Fig 38

Infotainment

Monster 821 can be fitted with the Ducati Multimedia System (DMS), thanks to which the user can answer phone calls, select and listen to music tracks, and receive SMS notifications by means of the Bluetooth technology.

The instrument panel displays the Infotainment function status: Bluetooth activation and any connected devices (smartphone, earphones, navigator).

When the Bluetooth is active, the main screen displays the Bluetooth icon (A).

Moreover, in the FULL and CORE layouts, the Infotainment functions are visible within the dedicated menus (B).

In the TRACK layout, the Infotainment functions concerning player are not visible on the instrument panel, but calls can nevertheless be answered/rejected/terminated using the function buttons.



Attention

All data concerning the Infotainment (Player, access to Contact List, Name of devices, etc.) are managed for use of Western character sets.

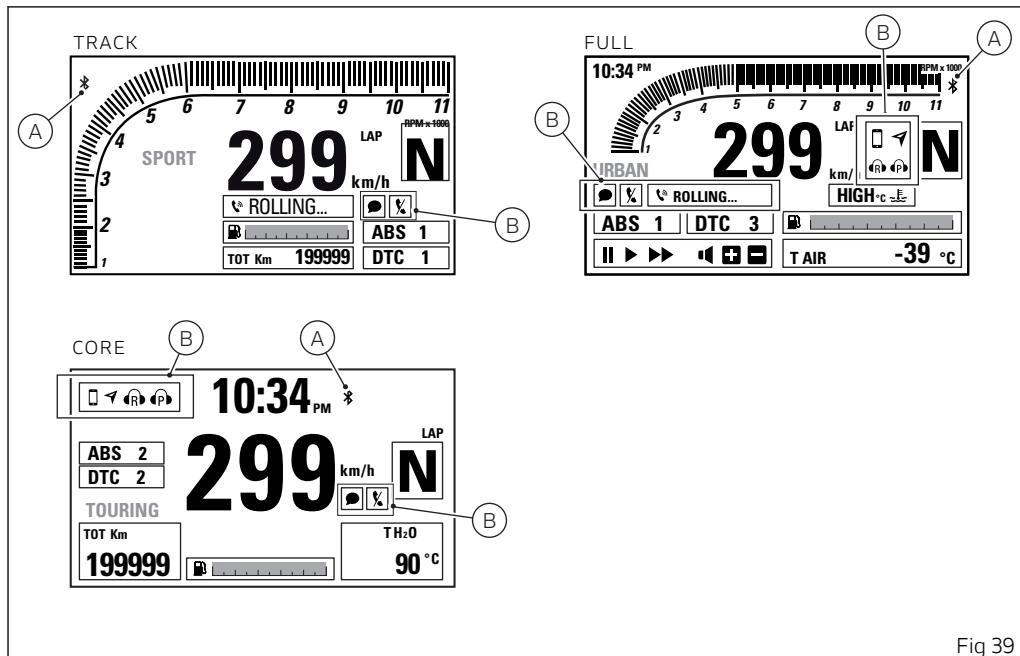

Fig 39

If Bluetooth is active, apart from the Bluetooth icon, also connected device indication is displayed, such as smartphone, rider and passenger helmet earphones, Ducati GPS navigator. It is possible to connect up to a maximum of 4 devices.

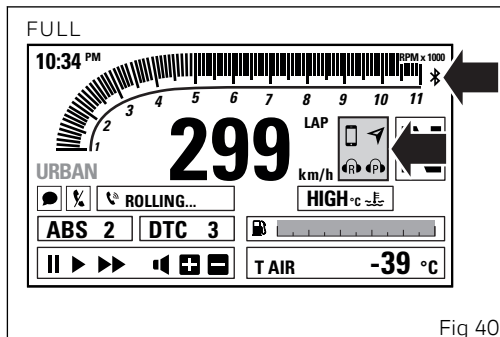

Fig 40

Phone

Use the PHONE function:

- to manage incoming calls by means of button (1) and button (2);
- to recall the last calling number within 5 seconds from call interruption (RECALL function).

To activate the Recall function within the 5 seconds, press button (1).



Note

It is not possible to make a call by selecting the name/number from the contact list through the function buttons.

When there is an incoming call (B) the blue colour filling the rectangle is flashing; while, when you answer the call, the blue background stops flashing. If there is an incoming call while the Player (A) is active, the latter is paused throughout the phone call and will resume operation when call is over.

To answer the call, press button (1).

To end the call, press button (2).

During 5 seconds after hang-up, the rectangle corresponding to the Recall function (C) is activated to allow the recall.

After this 5 second time, the rectangle for the recall function is disabled.

FULL

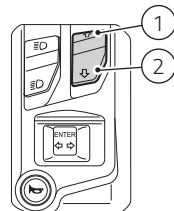
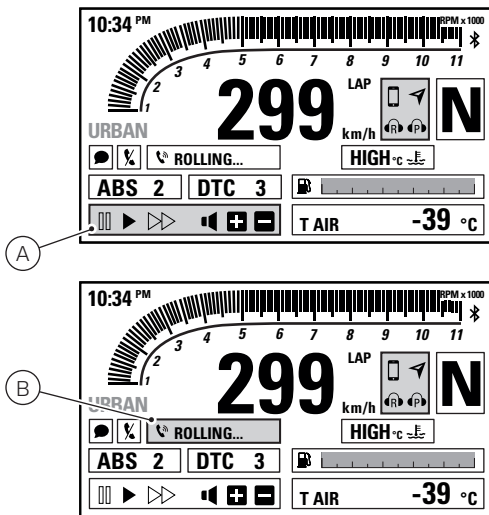

Fig 41

In case of missed calls from the moment the smartphone is connected to the bike to the moment it is disconnected, the missed call symbol will be displayed (timed).

In case there is at least one SMS/MMS/EMAIL not read from the moment the smartphone is connected to the bike to the moment it is disconnected, the unread message symbol will be displayed. The number of unread messages is not displayed.

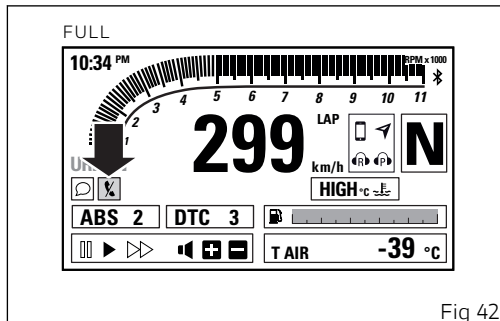

Fig 42

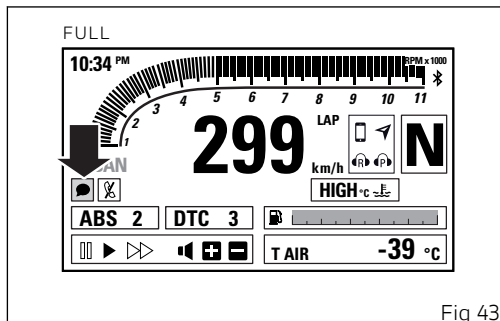

Fig 43

Player

The Player can be activated only in FULL or CORE riding mode.

If at least one Smartphone device is connected (blue icon on main screen), Menu 1 in the FULL and CORE layouts will include PLAYER OFF option.

The Player is activated by pressing button (4).

On instrument panel, Menu 1 includes PLAYER ON option and the Player controls are activated. To access the player controls, keep button (4) pressed for 2 seconds. When the Player is turned on, button (1), button (2) and button (4) can only be used to control the PLAYER.

If the Player is ON, but instrument panel is not receiving track name, it pauses the track being played and the message "NOT AVAILABLE" is displayed within the track name box.

Important

The Player function can not be activated through Menu 1 when a call is incoming, in progress or in recall.

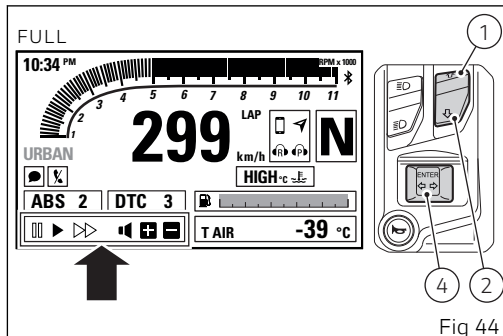

Fig 44

Adjust volume as follows:

- increase volume: press button (1);
- decrease volume: press button (2).

The Player can be cyclically set to pause/play by pressing button (4) for 2 seconds.

It is possible to skip to next track, pressing button (4): system will skip forward once every time button is pressed.

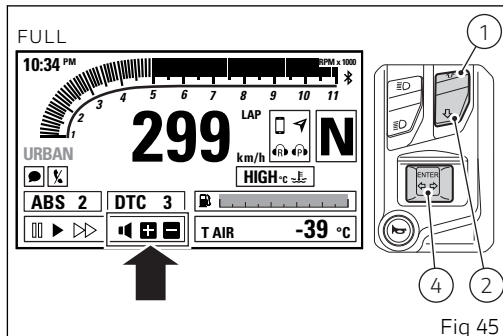

Fig 45

Press button (2) for 2 seconds to quit Player controls:
PLAYER ON message remains displayed but player graphics are no longer displayed.

After quitting player controls, press button (4) to
turn player off: PLAYER OFF message will be
displayed.

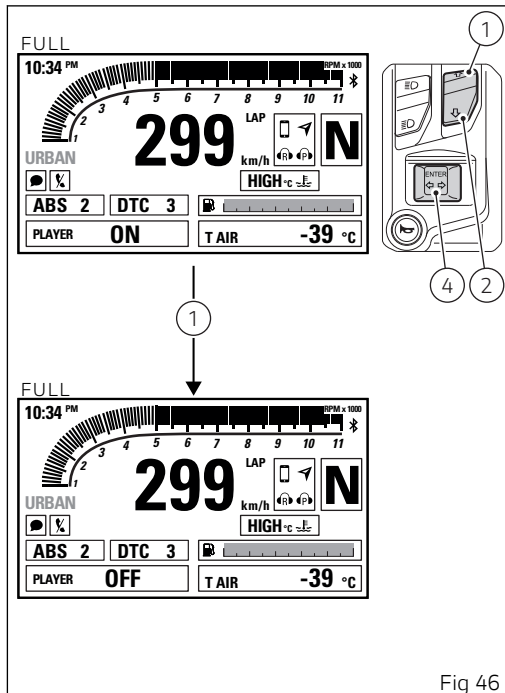

Fig 46

F.A.Q.

1) Why don't I receive any notification of received e-mails?

E-mails are notified only if configured on the telephone source application. Check also that your phone supports the MAP profile.

If so, the DUCATI MULTIMEDIA SYSTEM, during the pairing phase, will send an access request to such profile which can be notified to the user explicitly (depending on the operating system) by requesting access authorisation to message notifications.

2) Why don't I receive any notification of received messages?

Check that your phone supports the MAP profile. If so, the DUCATI MULTIMEDIA SYSTEM, during the pairing phase, will send an access request to such profile which can be notified to the user explicitly (depending on the operating system) by requesting access authorisation to message notifications.

3) Earphones do not connect. Why?

If they have been already paired once, we recommend resetting the earphones and pair them again with the motorcycle (see earphones instruction manual).

4) When I receive a call, the instrument panel displays the caller number but not the name (despite being saved in the contact list).

Check that the phone supports the PBAP profile. If so, the DUCATI MULTIMEDIA SYSTEM, during the pairing phase, will send an access request to such profile which can be notified to the user explicitly (depending on the operating system) by requesting access authorisation to the phone contact list.

5) By activating the Player through the instrument panel, music does not start.

The activation depends on the phone settings. In this case, after activating the Player through the instrument panel, also start the music application on your Smartphone.

6) It happens that the music is played with continuous interruptions.

If the devices have just been connected, it may be that the Bluetooth control unit is still completing the connection phase with the concerned devices. It is furthermore necessary to activate the PBAP and MAP profiles. Therefore, in case of iOS, please refer to point 7). In case of Android, please refer to points 2)4)

7) I do not receive any message notification on my iPhone. Why?

Select Bluetooth in the Setting Menu. In the list "My devices" select "i" next to "Ducati Media System".
Flag "Show notifications".

Service indication (SERVICE)

This indication shows the user that the motorcycle is due for service and must be taken to a Ducati Authorised Service Centre.

The service warning indication can be reset only by the Authorised Ducati Service Centre during servicing.

Icon display follows the displaying procedure of Warnings/Alarms ("page 100").



Note

Shown display mode is the FULL layout, icon indication procedure is the same for the CORE and TRACK modes.

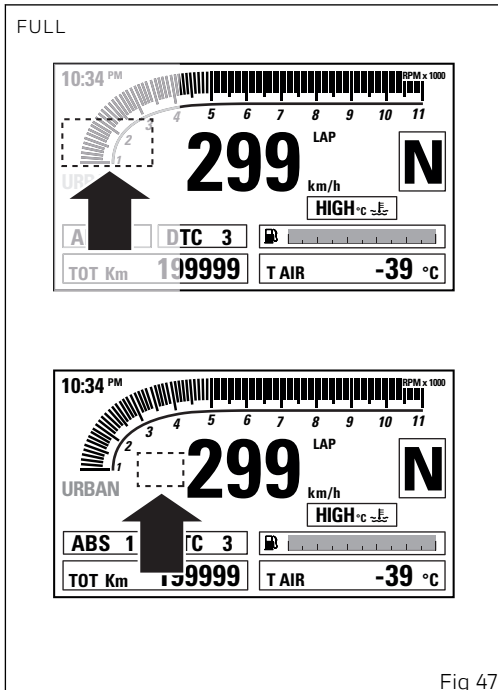

Fig 47

OIL SERVICE zero warning

The first service warning is the OIL SERVICE zero (red icon) and is triggered upon every Key-On for 5 seconds, as soon as the odometer reaches the first 1000 km (600 mi). Warning is displayed in the "large" size and then continues being displayed in the small size until "Reset" by the Ducati authorised service centre, during maintenance.

Icon display follows the displaying procedure of Warnings/Alarms ("page 100").

Note

Shown display mode is the TRACK layout, icon indication procedure is the same for the CORE and FULL modes.

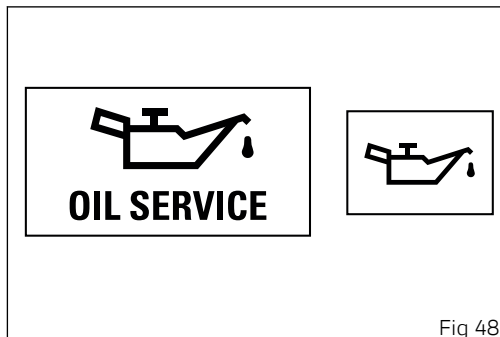

OIL SERVICE or ANNUAL SERVICE or DESMO SERVICE countdown indication

After Oil Service zero indication first reset (at 1,000 km - 600 mi), the instrument panel activates the following indications in yellow for 5 seconds upon Key-ON:

- the count of the mileage in kilometres (miles) remaining before the next OIL SERVICE (A) 1000 km (600 mi) earlier than the service threshold;
- the count of the days remaining before the next ANNUAL SERVICE (B) 30 days earlier than the service threshold;
- the count of the mileage in kilometres (miles) remaining before the next DESMO SERVICE (C) 1000 km (600 mi) earlier than the service threshold.

To know exactly the kilometres missing until the service threshold or maintenance date, it is possible to access the Setting menu and select the "SERVICE" function page 174.

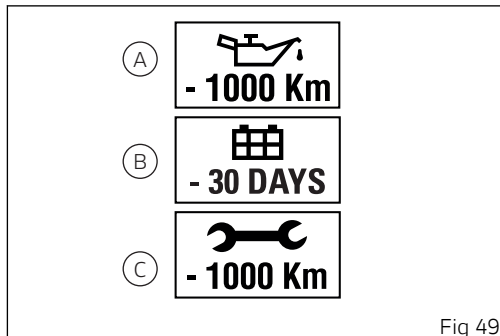

Fig 49

OIL SERVICE or ANNUAL SERVICE or DESMO SERVICE indication

When the service threshold is reached, the warning for the type of service required is triggered:

- Oil Service (A):
- Annual Service (B);
- Desmo Service (C).

The red icon of the due service is triggered upon every Key-On for 5 seconds and is displayed in the "large" size, and then continues being displayed in the small size until "Reset" by the Ducati authorised service centre, during maintenance.

To know the kilometres missing until the service threshold or maintenance date, access the Setting menu and select the "SERVICE" function page 174. Icon display follows the displaying procedure of Warnings/Alarms ("page 100").

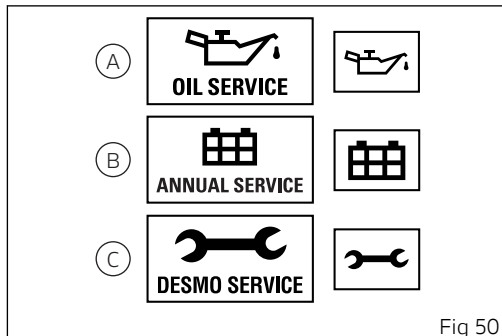

Fig 50

Warnings/Alarms (WARNING)

The instrument panel manages a number of warnings / alarms, aimed at giving useful information to the rider during use.

Upon Key-On, if there are any active warnings, the instrument panel displays the present warnings.

During normal use, whenever a warning is triggered, the instrument panel automatically displays the warning. Whenever a warning is triggered, it is displayed for 5 seconds in a (well-visible icon) "large" size and then continues being displayed in the small size ("small" icon).

If several warnings are active, the corresponding icons will be displayed one after the other, each remaining on display for 3 seconds.

When warnings are activated, no warning light will come on.

High engine coolant temperature (High temperature)

This function warns the rider when engine coolant temperature reaches 121°C (250°F).

Note

In this case, Ducati recommends stopping riding and turning engine immediately off; making sure that fans are working.

Note

Shown display mode is the TRACK layout, icon indication procedure is the same for the CORE and FULL modes.

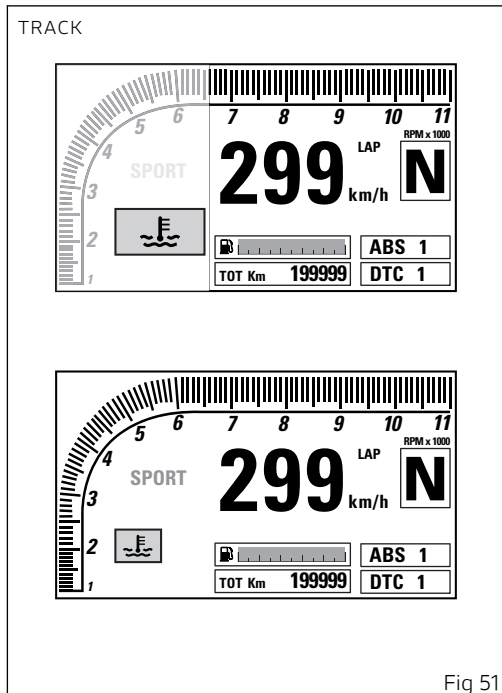

Fig 51

Ice

This function warns the rider when there might be ice on the road, due to the low external temperature. This warning turns on when temperature drops to 4°C (39°F) and turns off when temperature rises to 6°C (43°F).

Attention

This warning does not eliminate the possibility of icy road areas even with temperatures above 4°C (39°F); when ambient temperature is "low", ride responsibly, especially on road areas not exposed to sunlight and/or on bridges.

Note

Shown display mode is the TRACK layout, icon indication procedure is the same for the CORE and FULL modes.

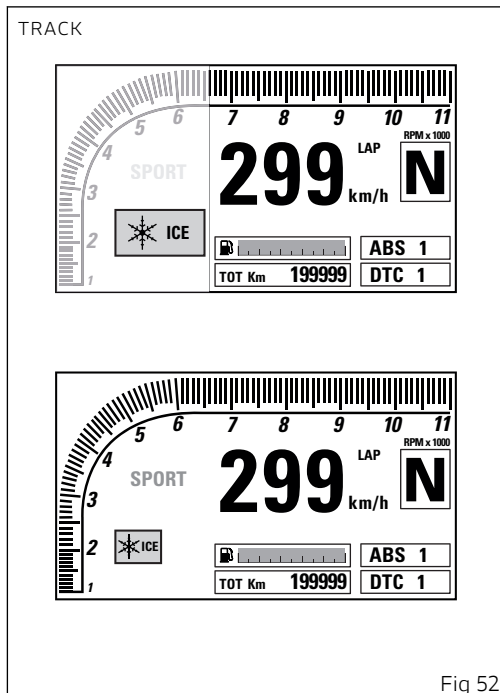

Fig 52

Date setting

This function prompts the user to enter the date via the Setting Menu.



Note

In this case Ducati recommends to stop and enter the calendar date using the function "DATESET".

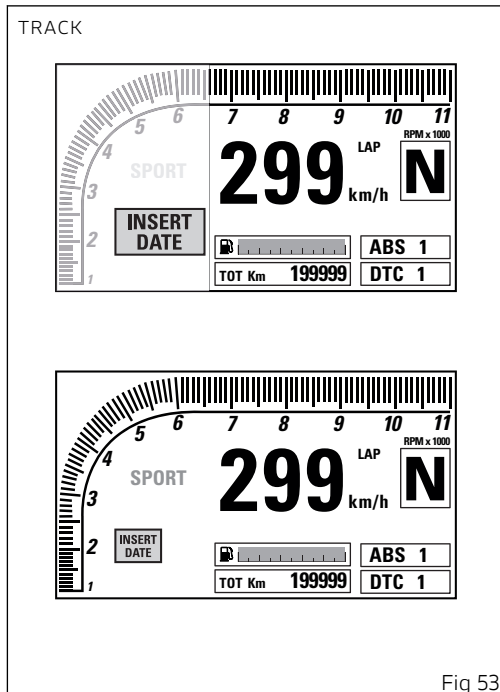

Fig 53

Low battery indication (LOW Battery)

This function warns the user that the status of the vehicle battery is low.

Warning is activated when battery voltage is approx. lower than/equal to 11.0 Volt.

Note

In this case, Ducati recommends charging battery in the shortest delay using the special instrument as engine could not be started.

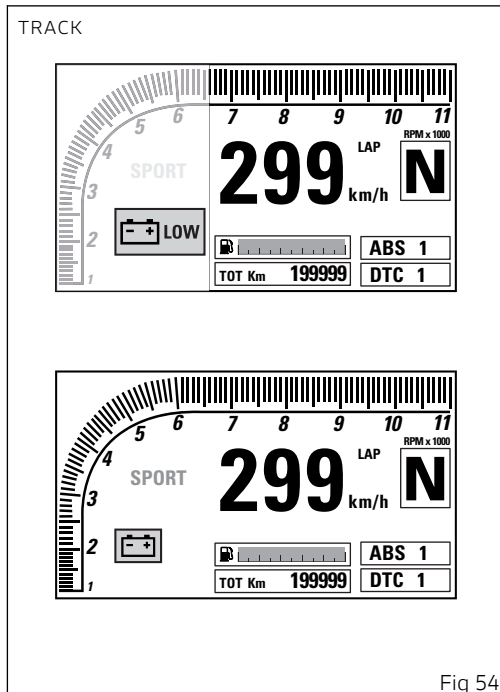

Fig 54

Error warnings

The instrument panel manages error warnings in order to allow the rider to identify any abnormal motorcycle behaviour in real time.

Upon Key-On, in case of errors, the instrument panel turns on the MIL light (B) (in case of errors directly connected to the engine control unit) or the Generic Error light (A) (in case of any other errors).

During normal operation, when an error is triggered, the instrument panel turns on the MIL light (B) or the Generic Error light (A).



Attention

When one or more errors are displayed, always contact a Ducati Dealer or authorised Service Centre.

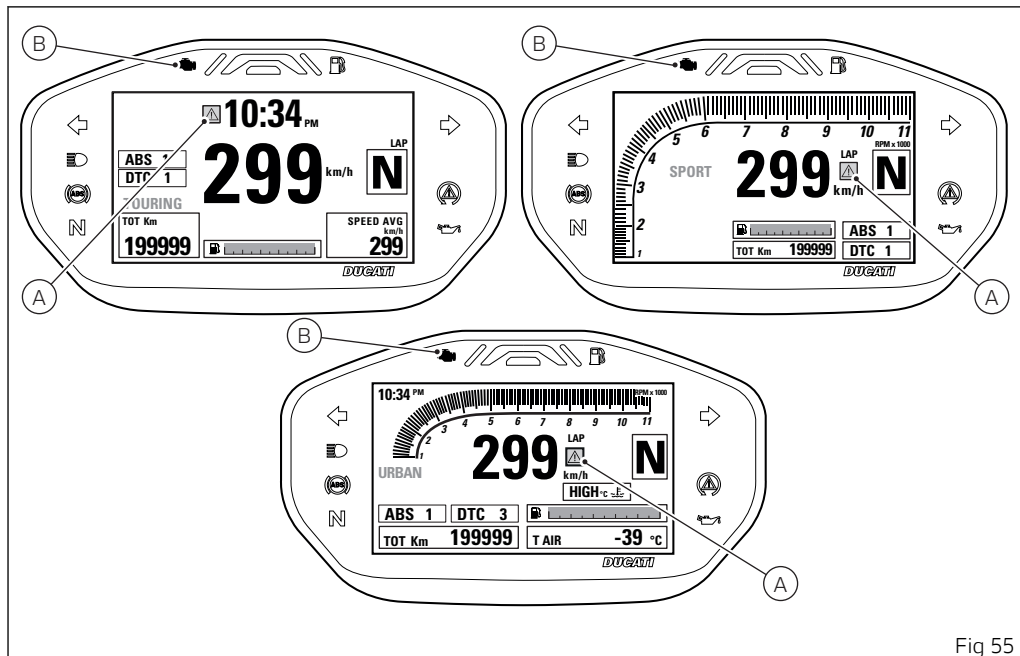

Fig 55

Viewing side stand status

The instrument panel shows the side stand status and if side stand is down/open, the icon SIDE STAND is displayed on a red background.

In case of Side stand sensor fault, the instrument panel will display the stand down/up indication with MIL light on.

If instrument panel does not receive side stand status, stand down/open SIDE STAND indication will flash to indicate an undefined status.

Note

With side stand down and gear engaged it is not possible to start the motorcycle. If you start with gearbox in neutral and then engage a gear with side stand down, the motorcycle turns off.

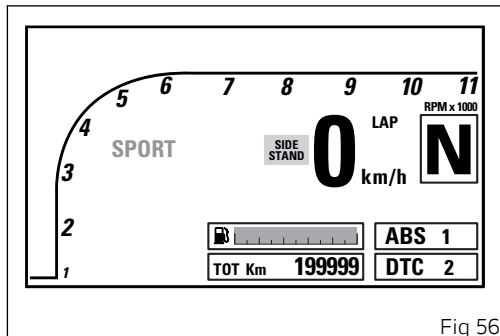

Fig 56

Setting menu

This menu allows enabling, disabling and setting some motorcycle functions.

To enter the Setting Menu it is necessary to hold button (2) for three seconds, with Key-ON and motorcycle actual speed \leq (lower than or equal to) 5 km/h (3 mph): within this menu, it is no longer possible to view any other function.

The Setting MENU displays the following functions:

- RIDING MODE
- DISPLAY
- PIN CODE
- LAP
- UNIT SETTING
- DATE & CLOCK
- BLUETOOTH
- SERVICE
- INFO
- TIRE SETTING



Important

For safety reasons, it is recommended to use this Menu with the motorcycle at a standstill.

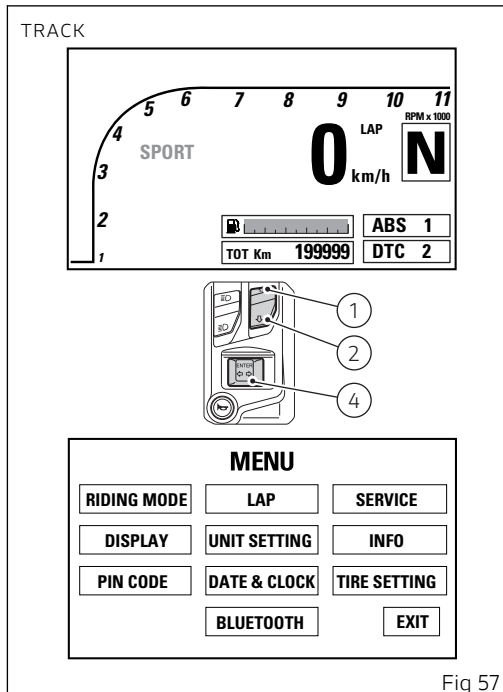

Fig 57

Press buttons (1) and (2) to highlight the customisable parameters one by one: in particular, use button (1) to highlight the following item and button (2) to highlight the previous item. After highlighting the required parameter, press button (4) to open the corresponding menu page. If function is not available or temporarily disabled, the menu page can not be opened. To quit the Setting Menu, you shall highlight "EXIT" and press CONFIRM MENU button.

Customising the RIDING MODE

All settings of every riding mode can be customised. You enter the Setting Menu.

Select "RIDING MODE" option, by pressing button (1) or (2). Once function is highlighted, press CONFIRM MENU button (4).

Enter the "RIDING MODE" menu. Select the desired riding mode (SPORT, TOURING or URBAN), by pressing button (1) or (2). Once the desired mode is highlighted, press CONFIRM MENU button (4). You open the selected riding mode customisation Menu. While if you highlight "EXIT" and press button (4) you quit the sub-menu and go back to previous page.

The parameters that can be customised for every riding mode are the following:

- ABS
- DTC
- ENGINE
- DEFAULT

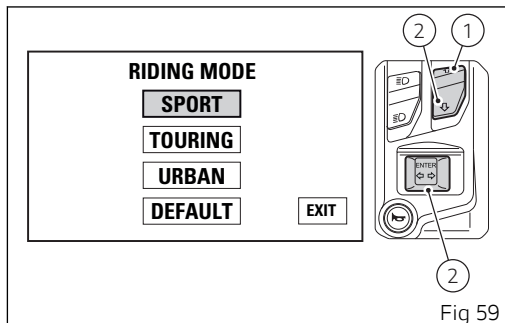
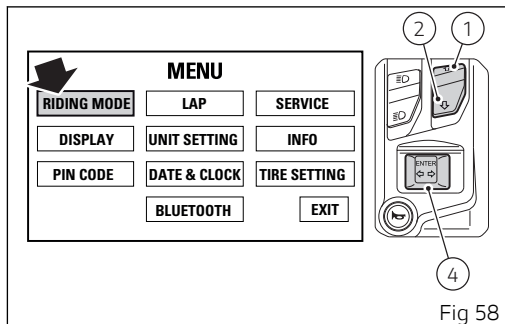

Press buttons (1) and (2) to highlight the customisable parameters one by one: in particular, use button (1) to highlight the following item and button (2) to highlight the previous item. After highlighting the required parameter, press button (4) to open the corresponding menu page. Any parameter change made is saved and remains in the memory also after a battery-off. The riding parameters set by Ducati can be restored for each single riding mode through the DEFAULT Function. If you highlight "EXIT" and press button (4) you quit the sub-menu and go back to previous page.

Attention

Changes should only be made to the parameters by people who are experts in motorcycle set-up; if the parameters are changed accidentally, use the "DEFAULT" function to restore factory settings.

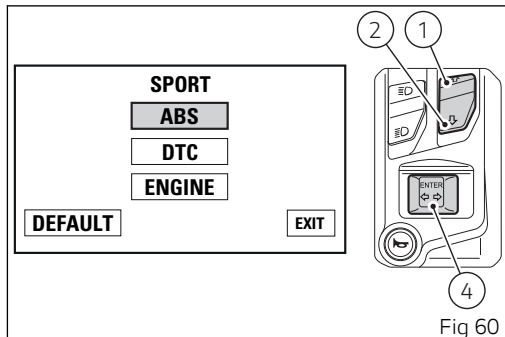

Customizing the Riding Mode: ABS adjustment

This function disables or sets ABS level for the selected riding mode. You enter the Setting Menu. Select "RIDING MODE" option, by pressing button (1) or (2).

Once function is highlighted, press CONFIRM MENU button (4).

Enter the "RIDING MODE" menu. Select the desired riding mode (SPORT, TOURING or URBAN), by pressing button (1) or (2).

Once the desired mode is highlighted, press CONFIRM MENU button (4). You open the selected riding mode customisation Menu. Select the parameter to be customised (ABS), by pressing button (1) or (2). Once the desired parameter is highlighted, press CONFIRM MENU button (4).

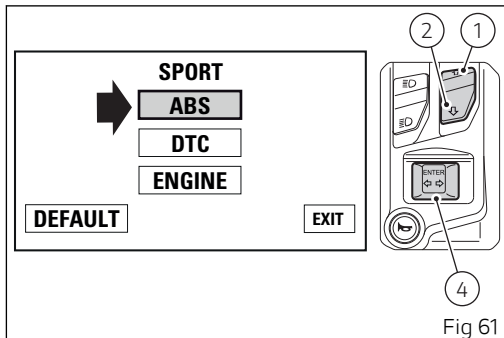

When entering the function, the currently set ABS level or status is indicated on the left (e.g.: ABS 1). Customisation options are indicated in the middle: levels 1 to 3.

Press buttons (1) and (2) to highlight the levels one by one: in particular, use button (1) to highlight the following item and button (2) to highlight the previous item.

Once the desired level is highlighted, press CONFIRM MENU button (4) to highlight MEMORY.

To save the new setting, hold button (4) for two seconds while the message MEMORY is highlighted in orange. If storage is successful, MEMORIZED will be highlighted in green for one second, level number or status will be refreshed (update is indicated in green) and then EXIT will be highlighted in green. To exit the menu and go back to previous page, select EXIT and press button (4).

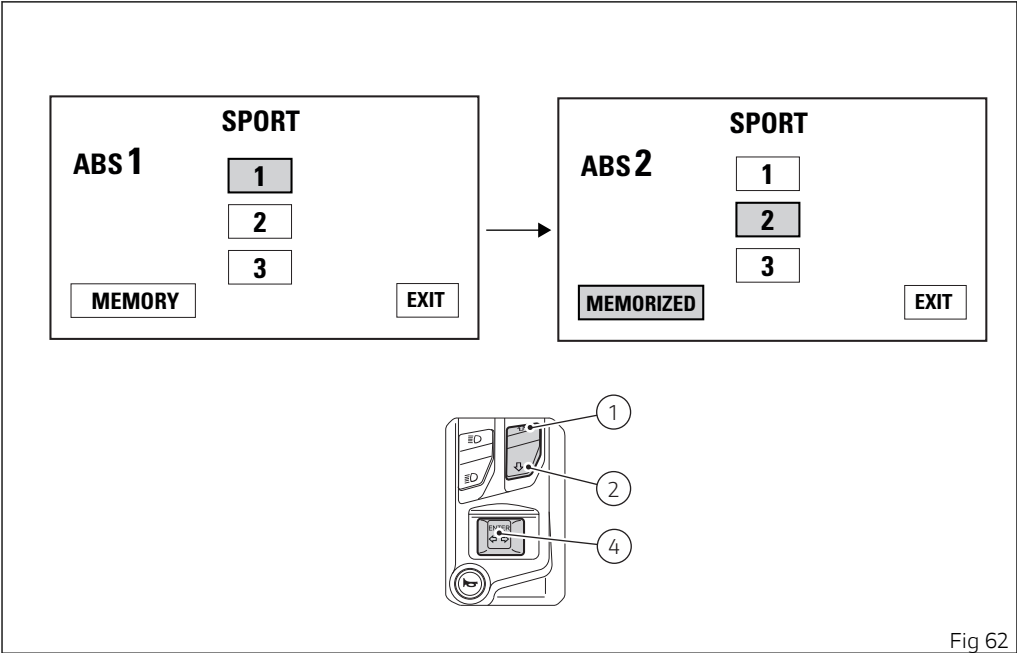

Fig 62

Customizing the Riding Mode: setting the DTC level

This function disables or sets DTC level for the selected riding mode.

You enter the Setting Menu. Select "RIDING MODE" option, by pressing button (1) or (2).

Once function is highlighted, press CONFIRM MENU button (4).

Enter the "RIDING MODE" menu. Select the desired riding mode (SPORT, TOURING or URBAN), by pressing button (1) or (2).

Once the desired mode is highlighted, press CONFIRM MENU button (4).

You open the selected riding mode customisation Menu.

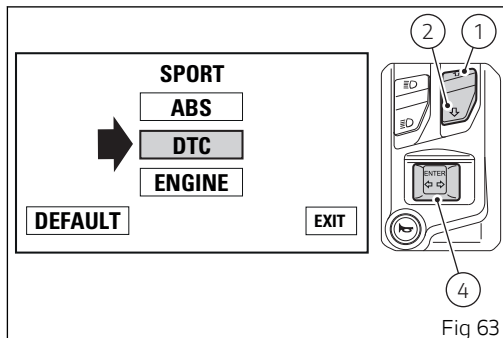

Fig 63

When entering the function, the currently set DTC level or status is indicated on the left (e.g.: DTC 3). Customisation options are indicated in the middle: levels 1 to 8 and status OFF.

Select the parameter to be customised (DTC), by pressing button (1) or (2).

Once the desired parameter is highlighted, press CONFIRM MENU button (4).

To save the new setting, hold button (4) for two seconds while the message MEMORY is highlighted in orange.

If storage is successful, MEMORIZED will be highlighted in green for one second, level number or status will be refreshed (update is indicated in green) and then EXIT will be highlighted in green.

To exit the menu and go back to previous page, select EXIT and press button (4).

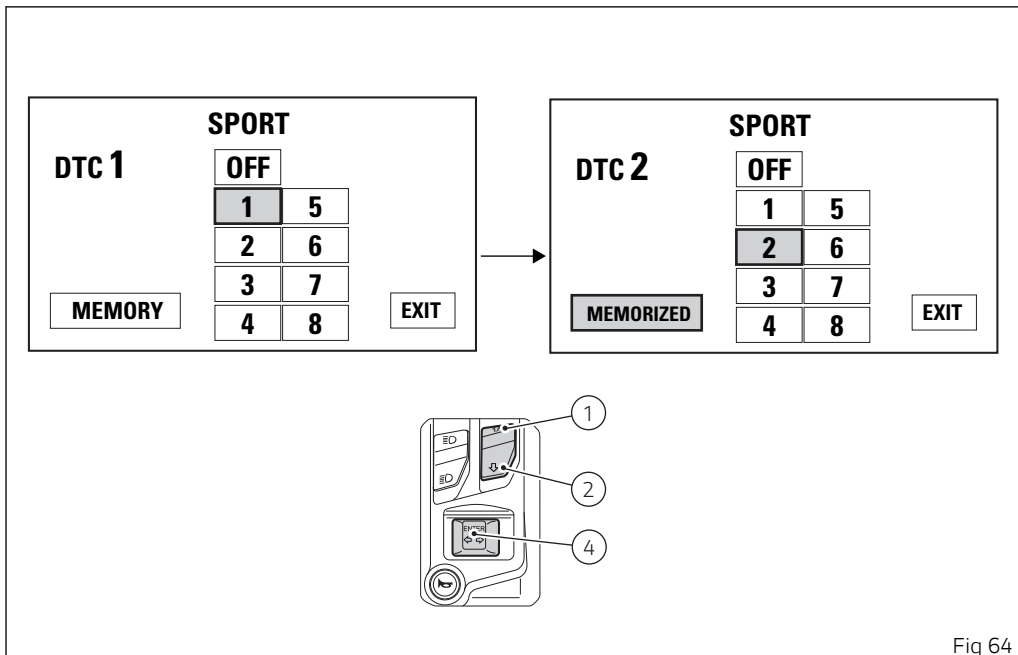

Fig 64

Customizing the Riding Mode: engine adjustment

This function customises engine power associated with each riding mode.

You enter the Setting Menu. Select "RIDING MODE" option, by pressing button (1) or (2).

Once function is highlighted, press CONFIRM MENU button (4). Enter the "RIDING MODE" menu. Select the desired riding mode (SPORT, TOURING or URBAN), by pressing button (1) or (2). Once the desired mode is highlighted, press CONFIRM MENU button (4).

You open the selected riding mode customisation Menu.

Select the parameter to be customised (ENGINE), by pressing button (1) or (2). Once the desired parameter is highlighted, press CONFIRM MENU button (4).

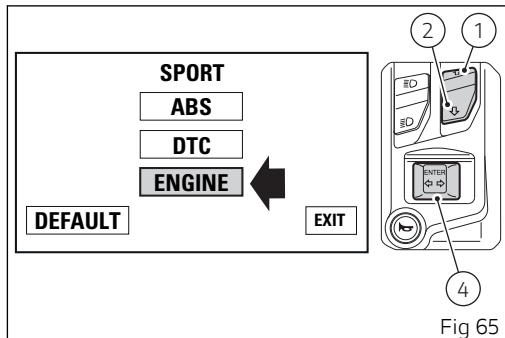

When entering the function, currently set engine power is indicated on the left (e.g.: ENGINE HIGH). Customisation options are listed in the middle:

- HIGH.
- MEDIUM
- LOW.

Press buttons (1) and (2) to highlight the available power options one by one: in particular, use button (1) to highlight the following item and button (2) to highlight the previous item.

Once the desired power level is highlighted, press CONFIRM MENU button (4) to highlight MEMORY. To save the new setting, hold button (4) for two seconds while the message MEMORY is highlighted in orange.

If storage is successful, MEMORIZED will be highlighted in green for one second, power level will be refreshed (update is indicated in green) and then EXIT will be highlighted in green.

To exit the menu and go back to previous page, select EXIT and press button (4).

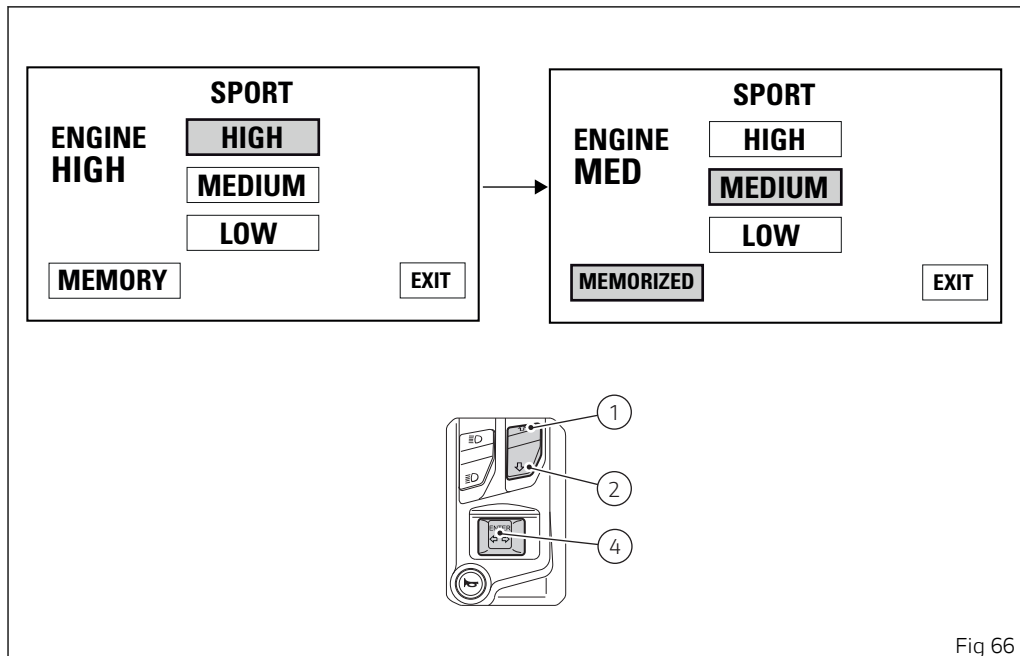

Fig 66

Customizing the Riding Mode: restoring default settings

Restoring default settings for every single riding mode

It is possible to reset the default parameters for every single riding mode or for all riding modes at once.

This function allows restoring the default values set by Ducati for the parameters relating to each riding mode. You enter the Setting Menu. Select "RIDING MODE" option, by pressing button (1) or (2). Once function is highlighted, press CONFIRM MENU button (4). Enter the "RIDING MODE" menu. Select the desired riding mode (SPORT, TOURING or URBAN), by pressing button (1) or (2). Once the desired mode is highlighted, press CONFIRM MENU button (4). You open the selected riding mode customisation Menu. Select the parameter to be customised (DEFAULT), by pressing button (1) or (2). Once desired parameter is highlighted, keep CONFIRM MENU button (4) pressed for 2 seconds.

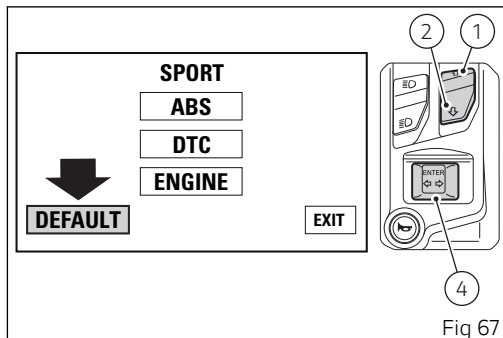

It will take 3 seconds to restore parameters, during which PLEASE WAIT ... will appear on the display. Once procedure is completed, DEFAULT OK will appear for two seconds to confirm that default parameters have been restored. The display then automatically goes back to Riding mode customisation menu first page, with EXIT option highlighted. To quit the menu and go back to Setting Menu main page, select EXIT and press button (4).

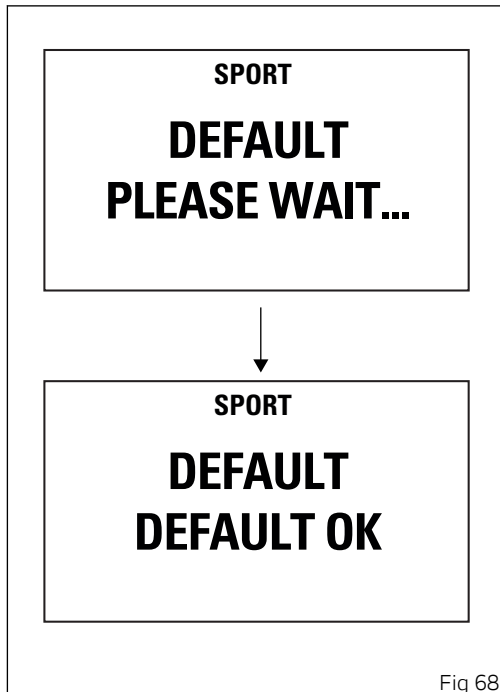
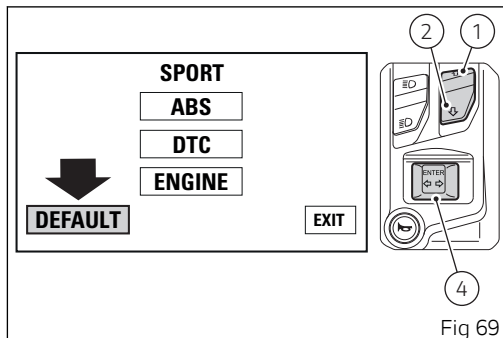

Fig 68

Restoring default settings for all riding modes at once

This function allows restoring the default values set by Ducati for the parameters relating to all riding modes. You enter the Setting Menu. Select "RIDING MODE" option, by pressing button (1) or (2). Once function is highlighted, press CONFIRM MENU button (4). Enter the "RIDING MODE" menu. Select by pressing button (1) or (2) and press CONFIRM MENU button (4) for 2 seconds.



It will take 3 seconds to restore parameters, during which PLEASE WAIT ... will appear on the display. Once procedure is completed, DEFAULT OK will appear for two seconds to confirm that default parameters have been restored. The display then automatically goes back to Riding mode customisation menu first page, with EXIT option highlighted. To quit the menu and go back to Setting Menu main page, select EXIT and press button (4).

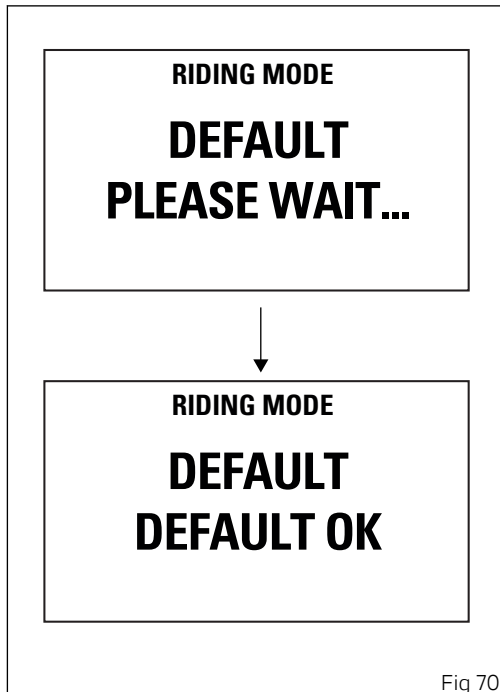
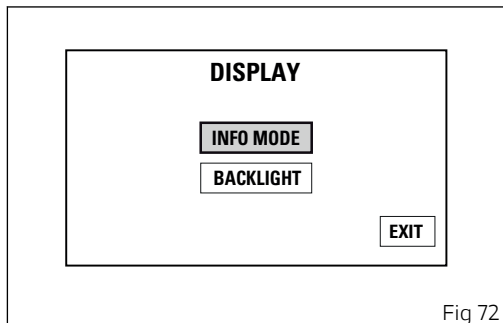
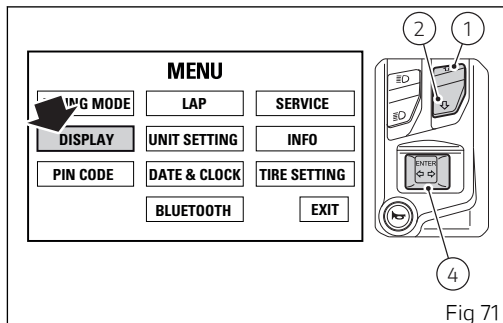

Fig 70

Display mode setting

The display mode can be customised by selecting one of the three available display modes: CORE, FULL and TRACK. Every mode is associated to a Riding Mode and in "Default" mode, when the Riding Mode changes, also the display mode changes. "Urban" Riding Mode is associated to the "Core" mode, "Touring" Riding Mode to the "Full" mode and "Sport" Riding Mode to the "Track" mode. Nevertheless, it is possible to select a specific display mode so that the instrument panel layout stays the same, regardless of the selected Riding Mode. You enter the Setting Menu. Select "DISPLAY" option, by pressing button (1) or (2). Once function is highlighted, press CONFIRM MENU button (4). Select "INFO MODE" option, by pressing button (1) or (2). Once function is highlighted, press CONFIRM MENU button (4).



When entering the function, currently set display mode is indicated on the left. The possible display views are shown in the middle: CORE, FULL, TRACK, DEFAULT.

Select the desired display mode (CORE, FULL or TRACK), by pressing button (1) or (2). Once mode is highlighted, press CONFIRM MENU button (4). The selected option is stored, current mode indication is refreshed and the EXIT option is automatically highlighted. Press button (4) to go back to previous display mode.

By selecting the "DEFAULT" mode, the instrument panel will apply to each selected Riding Mode the default display mode. If, otherwise, you select a specific display mode, this will be kept regardless of the selected Riding Mode.

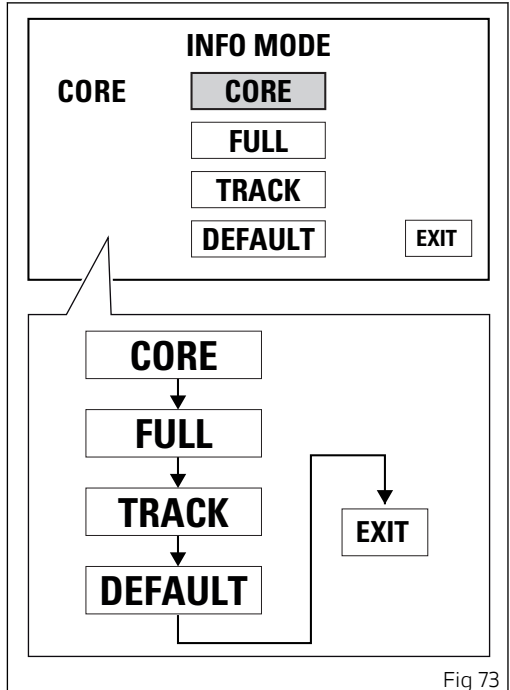

Display backlighting setting

This function allows selecting the instrument panel backlighting.

You enter the Setting Menu. Select "DISPLAY" option, by pressing button (1) or (2). Once function is highlighted, press CONFIRM MENU button (4).

Select "BACKLIGHT" option, by pressing button (1) or (2). Once function is highlighted, press CONFIRM MENU button (4).

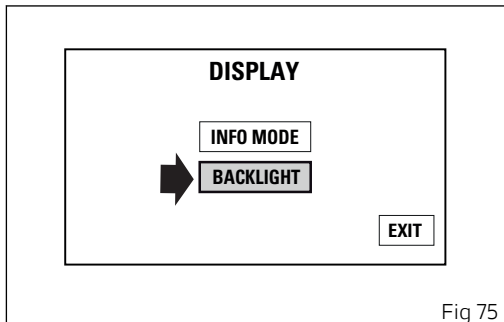
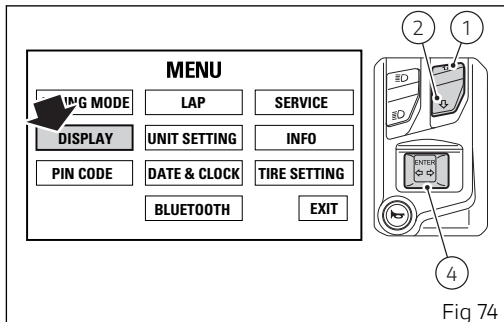

When entering the function, the currently set background status is indicated on the left. The possible background settings are shown in the middle: DAY, NIGHT, AUTO

Press buttons (1) and (2) to highlight the instrument panel backlighting options one by one: in particular, use button (1) to highlight the following item and button (2) to highlight the previous item. Once the desired backlighting option is highlighted, press CONFIRM MENU button (4) to confirm. The instrument panel immediately activates the backlighting option selected by the user and highlights the corresponding name.

Select DAY (day mode) to permanently set display "white" background for improved readability - recommended in conditions of strong ambient light.

Select NIGHT (night mode) to permanently set display black background for dimmed visibility - recommended in case of poor ambient light and/or at night.

Select AUTO (automatic mode) to automatically adjust background colour according to ambient light (detected by a sensor).

It will be "white" for better visibility with high ambient light and "black" for a dimmed visibility with low ambient light.

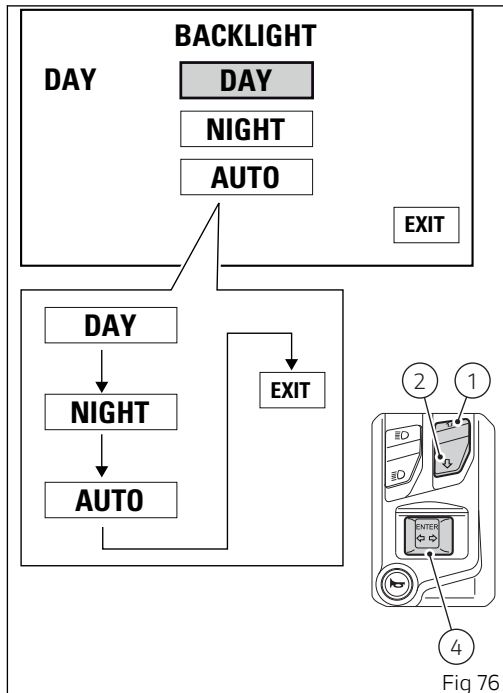

Fig 76

To exit the menu and go back to previous page,
select EXIT and press button (4).

PIN CODE

This function makes it possible to temporarily turn on the motorcycle if the Immobilizer system is not working.

The PIN CODE is initially not present in the motorcycle, it must be activated by the user by entering his/her 4-digit PIN in the instrument panel, otherwise the motorcycle cannot be started temporarily in the case of a malfunction. To activate this function, refer to "Entering the PIN CODE" procedure.

To change the PIN refer to "Changing the PIN CODE" procedure.

In order to temporarily start the motorcycle in case of malfunction of the Immobilizer system, please refer to the Vehicle Release procedure.



Attention

The motorcycle owner must activate (store) the PIN code; if there is already a stored PIN, contact an Authorised Ducati Dealer to have the function "reset". To perform this procedure, the Authorised Ducati Dealer may ask you to demonstrate that you are the owner of the motorcycle.

Entering the PIN CODE

To activate the PIN CODE function and enter your own PIN CODE you must open the Setting Menu. Select "PIN CODE" option, by pressing button (1) or (2).

Once function is highlighted, press CONFIRM MENU button (4).

You open the "PIN CODE" menu.

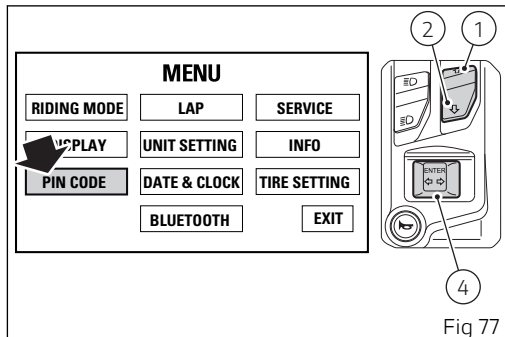

Fig 77

When entering the function, the display shows the message INSERT PIN CODE followed by four green dashes "----".

Entering the code:

- 1) Press button (4), only one digit indicating "0" turns green;
- 2) Each time you press the button (2) the displayed number increases by one (+ 1) up to "9" and then starts back from "0";
- 3) Each time you press the button (1) the displayed number decreases by one (- 1) up to "1" and then starts back from "0";
- 4) To confirm the number, press the button (4);

Repeat the procedures until you confirm all the 4 digits of the PIN CODE.

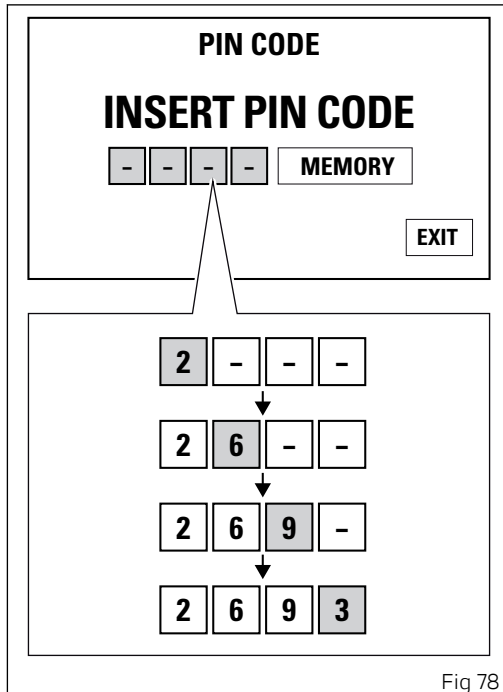

When you press button (4) to confirm the fourth and last digit, the instrument panel highlights the message MEMORY.

To save the new setting, hold button (4) for 3 seconds while the message MEMORY is highlighted in orange.

If storage is successful, MEMORIZED will be highlighted in green for 1 second, and then EXIT will be highlighted in green.

Once the first PIN CODE is stored, this menu page is no longer available and is replaced by the page for changing the PIN CODE. The page for entering the very first PIN CODE is active and available again only in case the PIN CODE function is reset (but this is only possible at a DUCATI Authorised Service Centre).

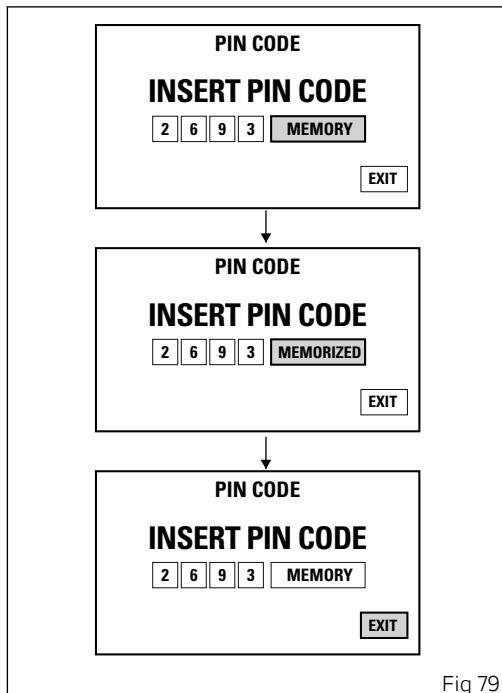

Fig 79

Changing the PIN CODE

To change the existing PIN CODE and activate a new one, you must open the Setting Menu.

Select "PIN CODE" option, by pressing button (1) or (2). Once function is highlighted, press CONFIRM MENU button (4). You open the "PIN CODE" menu. When entering the function, the display reads OLD CODE with four dashes in green "-" - "-" and NEW CODE below that.

Entering the "old" code:

- 1) Press button (4), only one digit indicating "0" turns green;
- 2) Each time you press the button (2) the displayed number increases by one (+ 1) up to "9" and then starts back from "0";
- 3) Each time you press the button (1) the displayed number decreases by one (- 1) up to "1" and then starts back from "0";
- 4) To confirm the number, press the button (4);

Repeat the procedures until you confirm all the 4 digits of the PIN CODE.

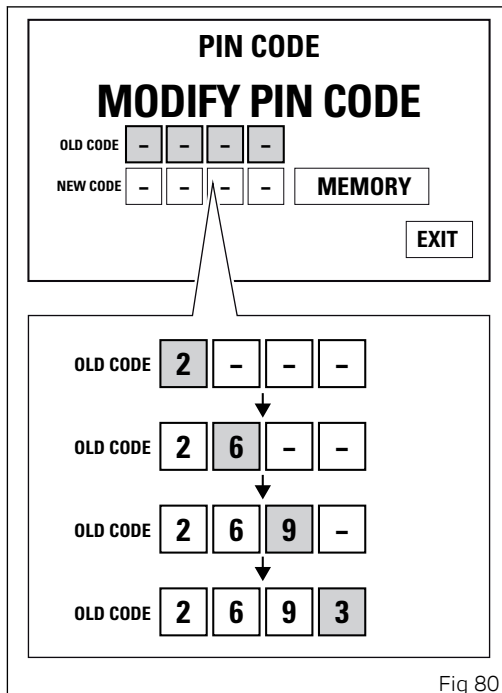

Fig 80

When you press button (4) to confirm the fourth and last digit:

- if the PIN is not correct, the instrument panel displays **WRONG** for 3 seconds and then highlights the string of four dashes "----" for the OLD PIN to allow you to try again;
- if there is a problem during the PIN code check, the instrument panel displays **ERROR** for 3 seconds and then highlights the message **EXIT**;
- if the PIN code is correct, the instrument panel displays **CORRECT** for 3 seconds and then highlights the four dashes "----" of the NEW PIN.

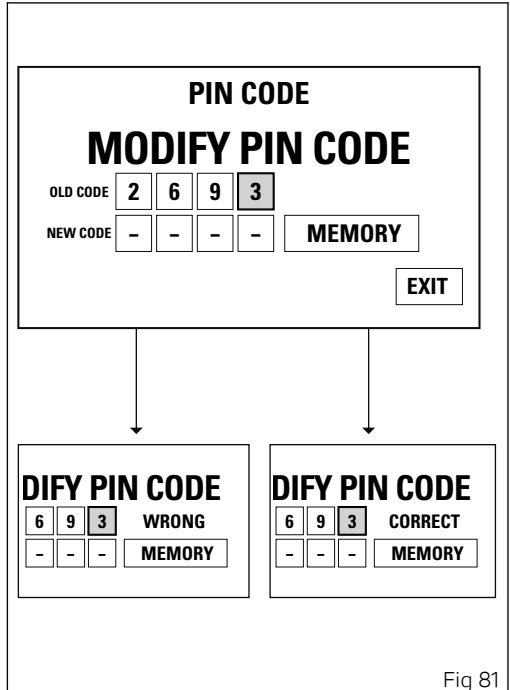

Fig 81

Entering the "new" code:

- 1) Press button (4), only one digit indicating "0" turns green;
- 2) Each time you press the button (2) the displayed number increases by one (+ 1) up to "9" and then starts back from "0";
- 3) Each time you press the button (1) the displayed number decreases by one (- 1) up to "1" and then starts back from "0";
- 4) To confirm the number, press the button (4)

Repeat the procedures until you confirm all the 4 digits of the PIN CODE.

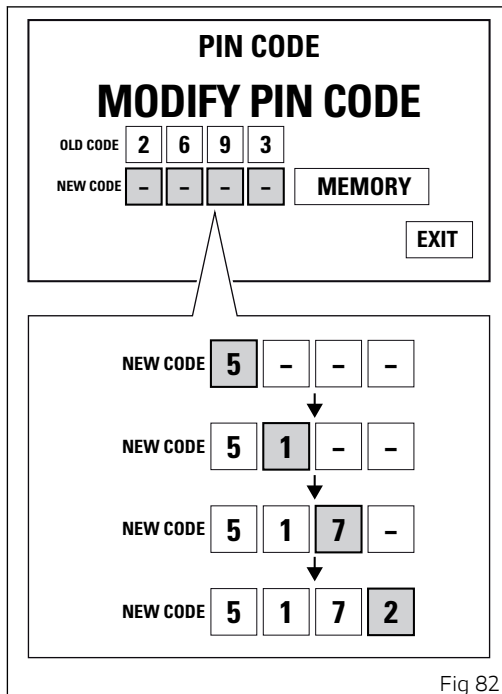

Fig 82

When you press button (4) to confirm the fourth and last digit, the instrument panel highlights the message MEMORY.

To save the new setting, hold button (4) for 3 seconds while the message MEMORY is highlighted in orange.

If storage is successful, MEMORIZED will be highlighted in green for 1 second, and then EXIT will be highlighted in green.

If settings have not been saved, the instrument panel highlights again the string of four dashes "----" of the NEW PIN to allow the rider to try again and enter a new code.

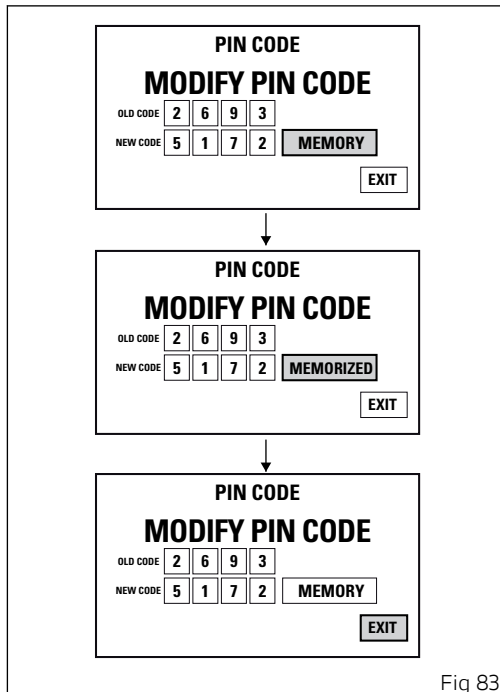

Fig 83

LAP

To open the LAP function menu, enter the Setting Menu. Select LAP option, by pressing button (1) or (2). Once function is highlighted, press button (4). You open the LAP Menu.

The menu allows you to:

- disable the LAP function using the OFF button;
- enable the LAP function using the ON button;
- view previously recorded LAPs ("LAP recording" function) using the LAP DATA button;
- delete recorded LAPs using the ERASE ALL button.

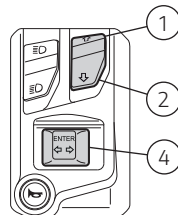
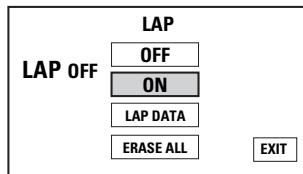
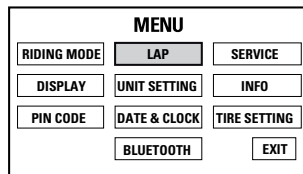

Fig 84

Displaying the stored Laps

To view the stored LAPs, you must enter the LAP menu.

Select "LAP DATA" option, by pressing button (1) or (2). Once function is highlighted, press CONFIRM MENU button (4).

When you enter the function, the following is displayed:

- The message LAP followed by the number of the LAP (e.g.: LAP 01);
- TIME followed by the recorded lap time;
- SPEEDMAX followed by the top speed reached during the lap;
- RPMMAX followed by the maximum RPM value reached during the lap.

Press the buttons (1) and (2) to highlight stored LAPS one by one; in particular: use button (2) to view the next lap (laps are displayed in increasing order, i.e. LAP 01 ... LAP 02 ... LAP 03 LAP 30); and then highlight EXIT; use button (1) to view the previous lap (laps are displayed in decreasing order, i.e. LAP 30 ... LAP 29 ... LAP 28 LAP 01); and then highlight EXIT.

To exit the menu and go back to previous page, select EXIT and press button (4).



Note

The MAX stored speed is reached during lap (increased by 5%).



Note

If the memory is empty, the display shows the lap timer reading "-.---.--", MAX RPM = ----- and MAX speed = -----.

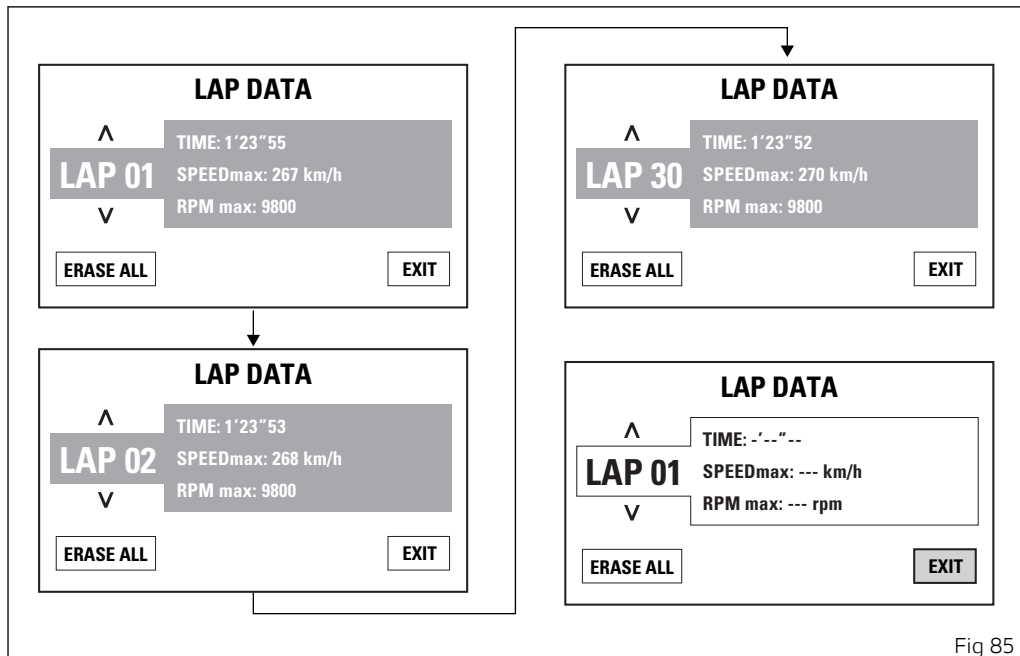

Fig 85

Erasing stored Laps

To erase the stored LAPS, you must enter the LAP menu.

LAPS can be erased from the LAP menu or from the LAP viewing page (LAP DATA).

Select "ERASE ALL" option, by pressing button (1) or (2). Once function is highlighted, press CONFIRM MENU button (4).

User must confirm deletion by pressing button (4) for 3 seconds.

After 3 seconds, the instrument panel display shows:

- ERASE LAP PLEASE WAIT... for 3 seconds;
- ERASE OK for 2 seconds to inform about the result of the deletion process.

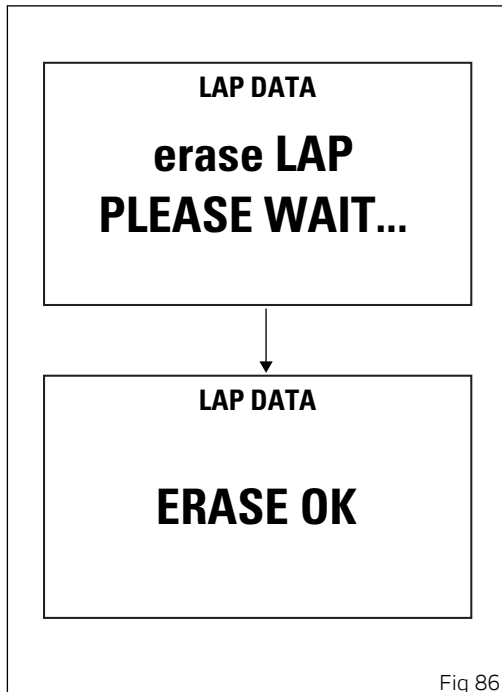

Fig 86

Deletion is one single command that erases all stored laps.

After deletion, the Laps 01 to 30 are displayed with all parameters showing an indefinite value "-" (time = -'---"---, rpm = -----, speed = ----).

To exit the menu and go back to previous page, select EXIT and press button (4).

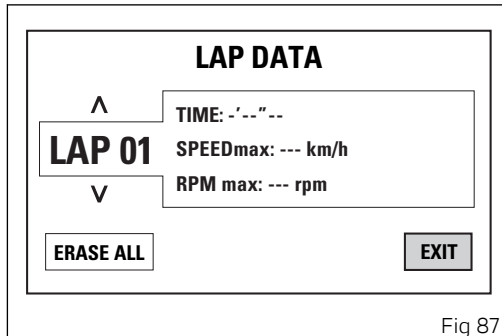

Fig 87

Setting the units of measurement

This function allows you to change the units of measurement of the displayed values, regardless of the Country configuration.

To manually set the units of measurement, you must enter the Setting Menu.

Select "UNIT SETTING" option, by pressing button (1) or (2). Once function is highlighted, press CONFIRM MENU button (4).

You enter the "UNITS SETTING" menu.

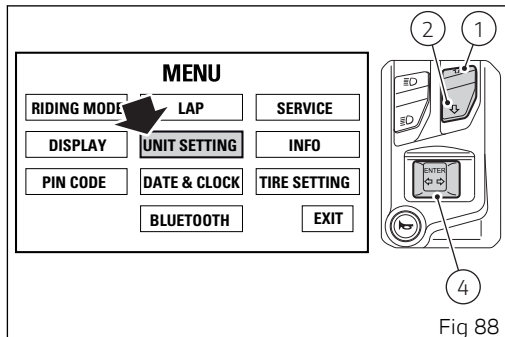

Fig 88

When entering the function, the display shows on the left the list of values for which units of measurements can be set:

- SPEED;
- temperature (TEMPERATURE);
- fuel consumption (CONSUMPTION);
- reset to automatic settings (DEFAULT).

To exit the menu and go back to previous page, select EXIT and press button (4).

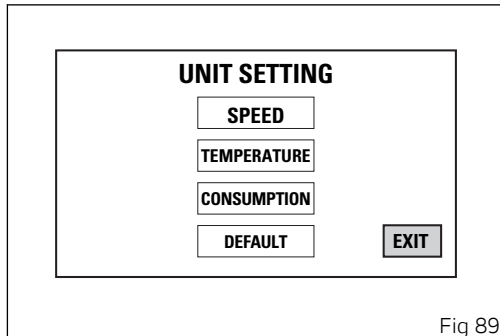

Fig 89

Setting the units of measurement: Speed

This function allows to change the units of measurement of speed (and hence even the ones of distance travelled).

You open the "UNITS SETTING" menu, as described on the previous pages. Select "SPEED" option, by pressing button (1) or (2).

Once function is highlighted, press button (4). You open the "SPEED" menu.

When you enter the function, the current unit of measurement is displayed, followed by the list of the possible units: km/h, mph.

Press buttons (1) and (2) to highlight the units of measurement one by one: in particular, use button (1) to highlight the following item and button (2) to highlight the previous item. Select the required unit of measurement and then press the button (4) to confirm: the selected unit is stored and the EXIT option is highlighted.

The selected unit of measurement will be used by the instrument panel for the following indications:

- Motorcycle speed and Average speed (km/h or mph);

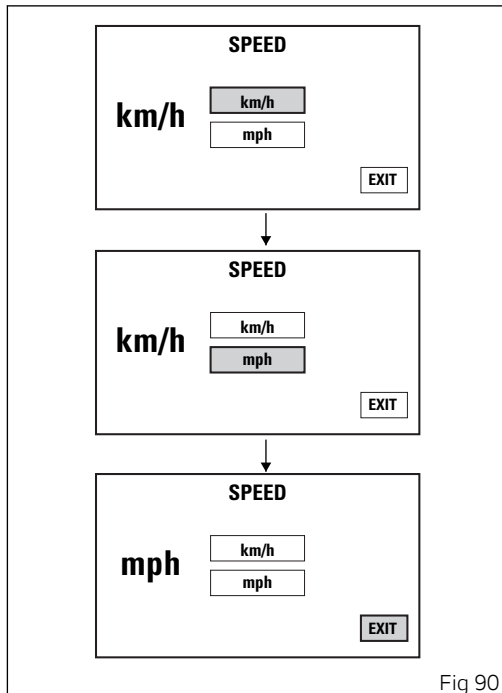

Fig 90

- Odometer, Trip1, Trip2 and Trip Fuel (km or mi).

Setting the units of measurement: Temperature

This function allows you to change the units of measurement of the temperature.

You open the "UNITS SETTING" menu, as described on the previous pages. Select "TEMPERATURE" option, by pressing button (1) or (2).

Once function is highlighted, press button (4).

You open the "TEMPERATURE" menu. When you enter the function, the current unit of measurement is displayed, followed by the list of the possible units: °C, °F.

Press buttons (1) and (2) to highlight the units of measurement one by one: in particular, use button (1) to highlight the following item and button (2) to highlight the previous item. Select the required unit of measurement and then press the button (4) to confirm: the selected unit is stored and the EXIT option is highlighted.

The selected unit of measurement will be used by the instrument panel for the following indications:

- Engine coolant temperature and ambient air temperature.

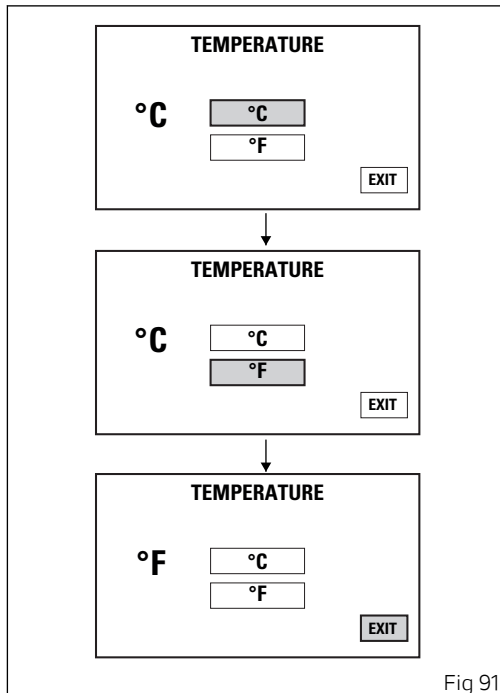

Fig 91

Setting the units of measurement: Fuel consumption

This function allows you to change the units of measurement of the fuel consumption.

You open the "UNITS SETTING" menu, as described on the previous pages. Select "CONSUMPTION" option, by pressing button (1) or (2).

Once function is highlighted, press button (4). You open the "CONSUMPTION" menu.

When you enter the function, the current unit of measurement is displayed, followed by the list of the possible units: L / 100km, km / L, mpg (UK), mpg (USA).

Press buttons (1) and (2) to highlight the units of measurement one by one: in particular, use button (1) to highlight the following item and button (2) to highlight the previous item.

Select the required unit of measurement and then press the button (4) to confirm: the selected unit is stored and the EXIT option is highlighted.

The selected unit of measurement will be used by the instrument panel for the following indications:

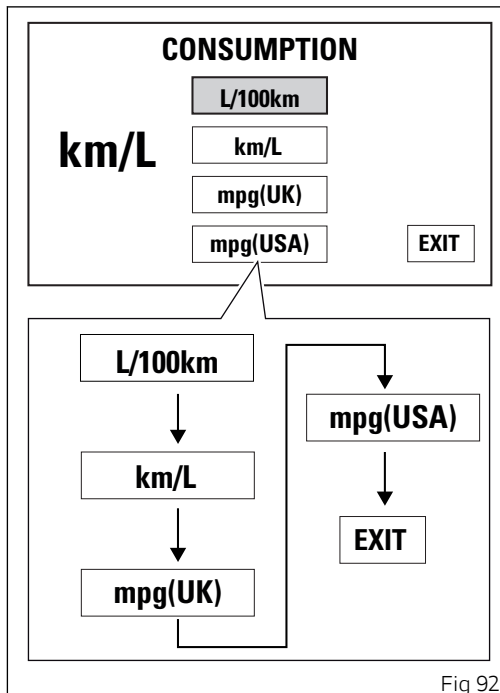

Fig 92

- Instantaneous fuel consumption and Average fuel consumption.

Setting the units of measurement: Reset to automatic settings

This function allows you to restore the automatic settings for the units of measurement of all indications displayed on the instrument panel. You open the "UNITS SETTING" menu, as described on the previous pages. Select "DEFAULT" option, by pressing button (1) or (2).

Once function is highlighted, press CONFIRM MENU button (4) for 2 seconds. PLEASE WAIT... will be displayed for 3 seconds, then DEFAULT OK will be displayed for 2 seconds, and then the UNITS SETTING menu page with the EXIT option highlighted.

To exit the menu and go back to previous page, select EXIT and press button (4).

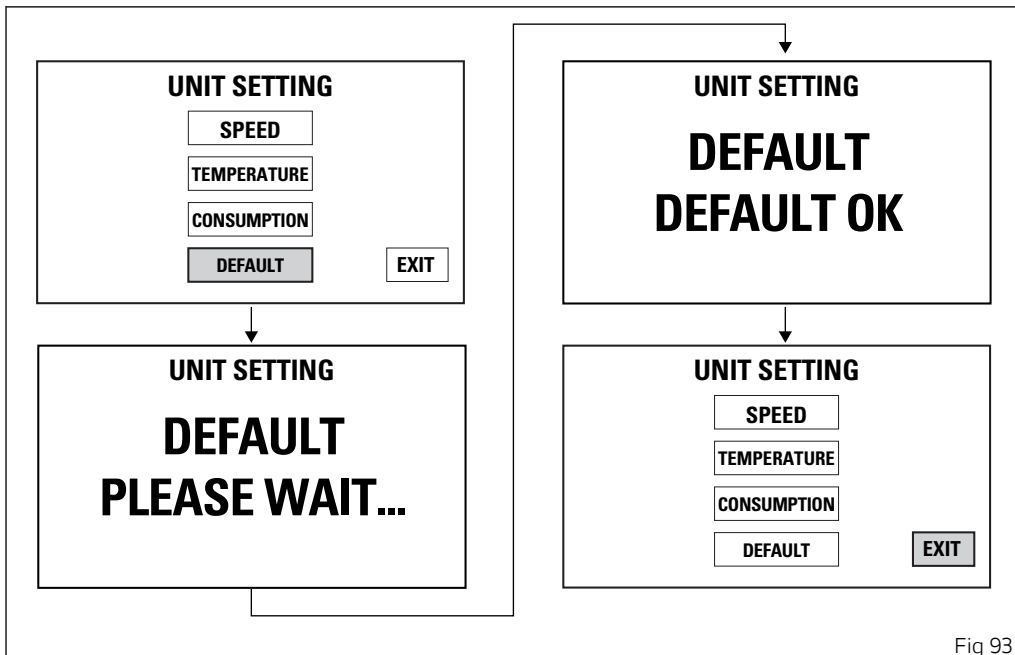

Fig 93

Date setting

This function allows user to set or change the date. You enter the Setting MENU.

Select "DATE & CLOCK" option, by pressing button (1) or (2).

Once function is highlighted, press CONFIRM MENU button (4).

Select "DATE" option, by pressing button (1) or (2). Once function is highlighted, press CONFIRM MENU button (4).



Important

Every time the battery is disconnected, the date is reset and must be set again.

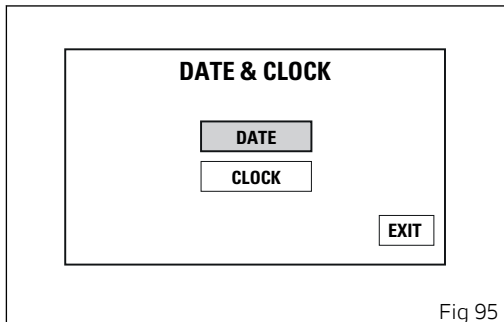
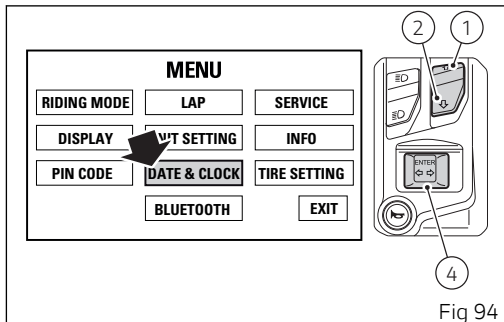

When entering the function, available settings are indicated on the left: YEAR, MONTH, DAY, while current date is indicated on the right (e.g.: 2014/08/02).

Year setting

Select "YEAR" option, by pressing button (1) or (2). Once highlighted, press CONFIRM MENU button (4).

Year value starts flashing.

Press button (1) to decrease year value by 1 unit:
2099, 2098, ... 2000, 2099.

Press button (2) to increase year value by 1 unit:
2000, 2001, ... 2099, 2000.

Once you reach the value to be set, press button (4) and the set year will stop flashing.

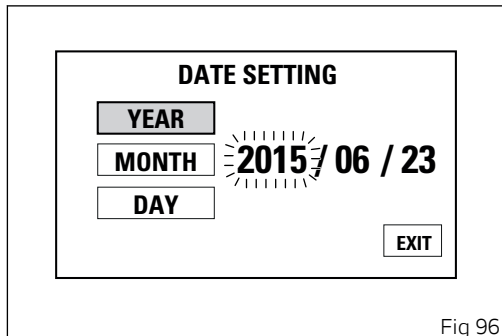

Fig 96

Month setting

Select "MONTH" option, by pressing button (1) or (2).

Once option is highlighted, press button (4).

Month value starts flashing.

Press button (1) to decrease month value by 1 unit: 12, 11, ... 01, 12.

Press button (2) to increase month value by 1 unit: 01, 02, ... 12, 01.

Once you reach the value to be set, press button (4) and the set month will stop flashing.

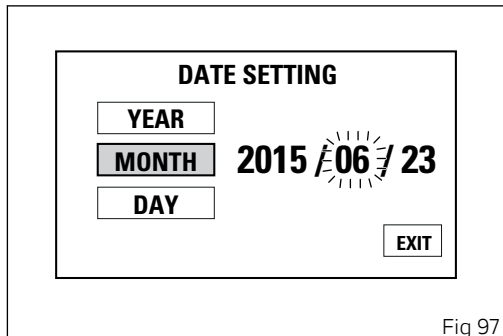

Fig 97

Day setting

Select "DAY" option, by pressing button (1) or (2).

Once option is highlighted, press button (4).

Day value starts flashing.

Press button (1) to decrease day value by 1 unit: 31, 30, ... 01, 31.

Press button (2) to increase day value by 1 unit: 01, 02, ... 31, 01.

Once you reach the value to be set, press button (4) and the set day will stop flashing.

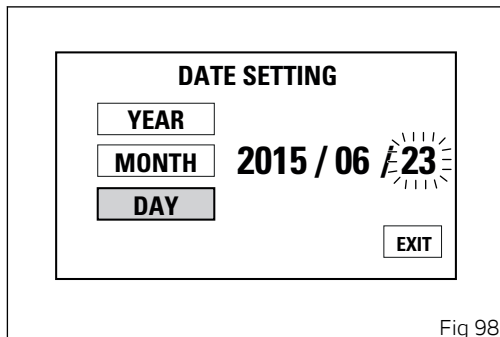

Fig 98

Storing the date

To store set/modified date, select MEMORY using buttons (1) and (2) and press button (4) for 2 seconds. The instrument panel will display MEMORIZED for two seconds and then automatically highlight EXIT.

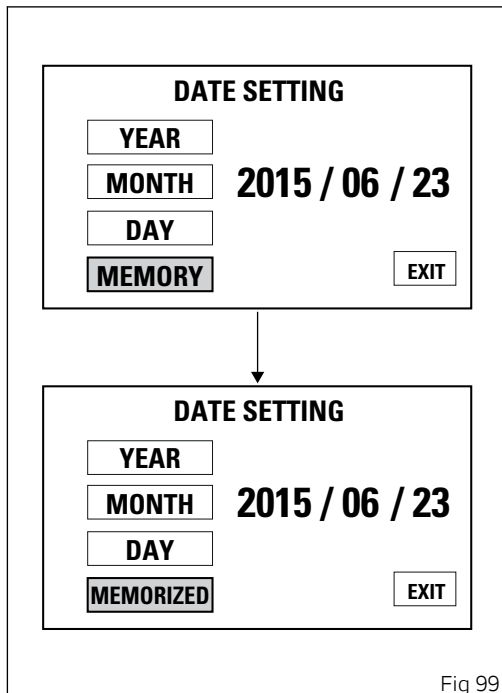

Fig 99

If date is not correct, the instrument panel will display "WRONG DATE" flashing for three seconds and then will automatically highlight EXIT, while date is indicated as "---- / -- / --" steady. It is still possible to set a new date.
To go back to previous page (setting menu page), press button (4) when EXIT is highlighted.

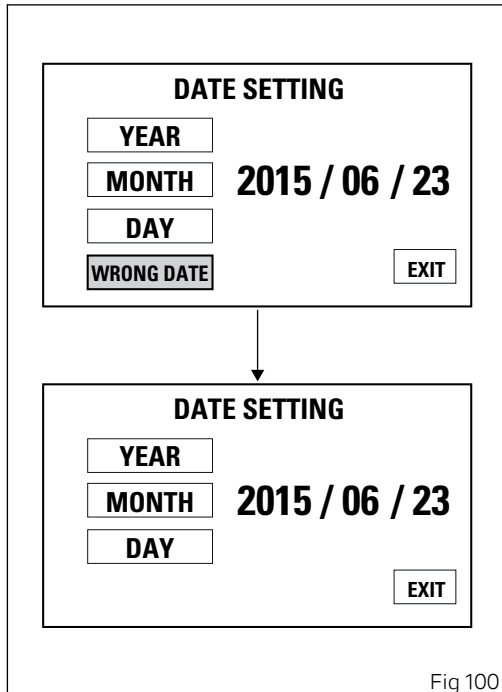

Fig 100

Clock setting

This function allows user to set or change the date. You enter the Setting MENU.

Select "DATE & CLOCK" option, by pressing button (1) or (2).

Once function is highlighted, press CONFIRM MENU button (4).

Select "CLOCK" option, by pressing button (1) or (2). Once function is highlighted, press CONFIRM MENU button (4).

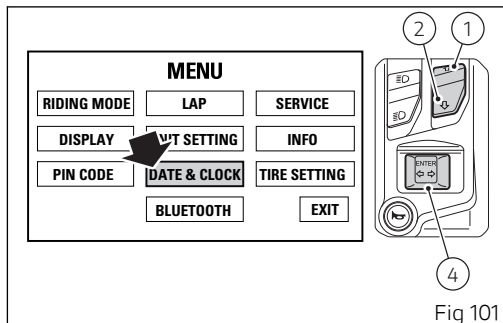

Fig 101

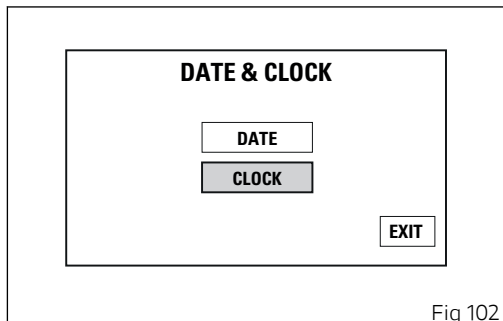

Fig 102

When entering the function, available settings are indicated on the left: HOUR, MINUTE, AM / PM, while current time is indicated on the right (e.g.: 10 : 57 a.m.).

Setting the hours

Select "HOUR" option, by pressing button (1) or (2). Once highlighted, press CONFIRM MENU button (4). Hour value starts flashing.

Press button (1) to decrease hour value by 1 unit: 12 to 01 and then again from 12.

Press button (2) to increase hour value by 1 unit: 01 to 12 and then again from 01.

Hold down button (1) or (2) for over a second to automatically decrease or increase units until button is released.

Once you reach the value to be set, press CONFIRM MENU button (4) and the set hour will stop flashing.

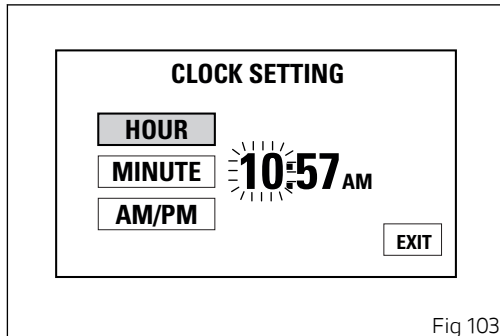

Fig 103

Setting the minutes

Select "MINUTE" option, by pressing button (1) or (2).

Once highlighted, press CONFIRM MENU button (4).

Minute value starts flashing.

Press button (1) to decrease minute value by 1 unit:
59, 58, ... 00, 59.

Press button (2) to increase minute value by 1 unit:
00, 01, ... 59, 00.

Hold down button (1) or (2) for over a second to automatically decrease or increase units until button is released.

Once you reach the value to be set, press CONFIRM MENU button (4) and the set minutes will stop flashing.

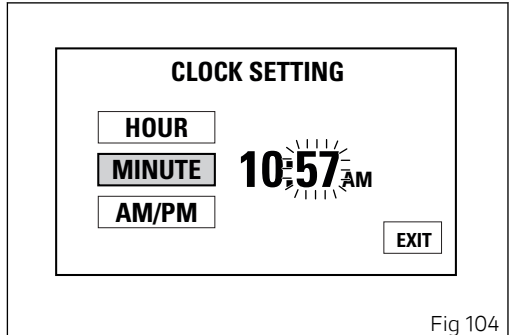

Fig 104

SM/PM setting

Select "AM/PM" option, by pressing button (1) or (2). Once highlighted, press CONFIRM MENU button (4).

The value will start flashing.

Select AM or PM option, by pressing button (1) or (2) respectively.

Once you reach the value to be set, press CONFIRM MENU button (4) and the set value will stop flashing.

To exit the menu and go back to previous page, select EXIT and press button (4).

Note

Every time the battery is disconnected, the clock is reset and must be set again by the user.

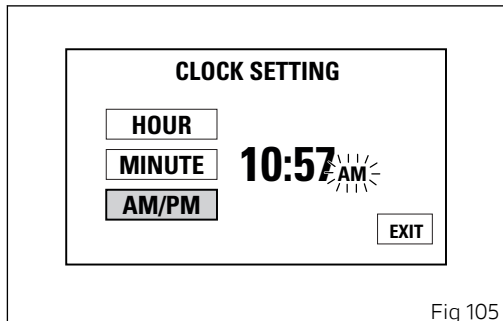

Fig 105

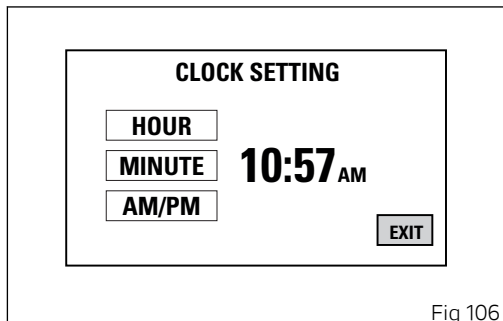

Fig 106

Bluetooth device setting

This function can be activated only if the Ducati Multimedia System (DMS) and the Bluetooth control unit are available: for this model the Bluetooth control unit can be purchased at a Ducati Dealer or Authorised Service Centre.

This function allows pairing and/or deleting any paired Bluetooth devices.

To do this, you must enter the Setting Menu.

Select "BLUETOOTH" option, by pressing button (1) or (2). Once function is highlighted, press button (4). You enter the "BLUETOOTH" menu, which is active only if the Bluetooth function is active.

The BLUETOOTH menu is not available if the player is active or being used, or when there is an incoming call, a call is in progress or during recall.

To carry out the pairing procedure, refer to "Pairing of a new device".

To delete any paired devices, refer to "Deleting a paired device".

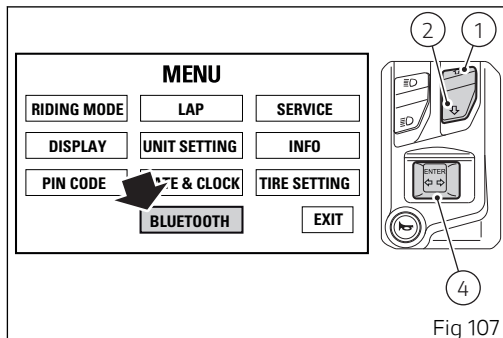

Fig 107

Pairing of a new device

This function allows user to associate (pair) one or several Bluetooth devices by running the "PAIRING" control.

Set the Bluetooth device to ensure it can be detected by the control unit, so turn device on and make it visible to other devices.

A Bluetooth device in visible mode transmits a wireless signal allowing it to be detected by other devices. This function is called pairing mode.

The motorcycle is equipped with a Bluetooth control unit that works as a hub between the various supported electronic devices relying on a Bluetooth communication interface.

Attention

Bluetooth Headset device manufacturers may incorporate certain changes within the standard protocols over the course of the lifecycle of the device (Smartphones and Earphones).



Attention

These changes are outside the control of Ducati and may result in Bluetooth Headset devices functionality becoming impaired (sharing Music, multimedia player, etc.) and may equally affect some types of Smartphones (depending on supported Bluetooth profiles). This is why Ducati cannot guarantee multimedia player proper operation for:

- any earphones not coming with the "Ducati Kit part no. 981029498";
- any Smartphones not supporting the required Bluetooth profiles (even though paired to earphones coming with the "Ducati Kit part no. 981029498").



Attention

In case of interference or noise due to particular conditions of the external environment, the Ducati earphone kit part no. 981029498 also allows sharing the music being played directly from rider helmet to passenger helmet (for further details please refer to the manual of the earphones coming with the Ducati kit part no. 981029498).



Note

The Ducati kit part no. 981029498 can be purchased separately at a Ducati Dealer or Authorised Service Centre.

Upon the first access to the BLUETOOTH Setting Menu, the first default displayed label will be "PAIRING" and on the left side the list of the device already paired.

The Pairing function is activated by pressing button (4): this runs a search for all Bluetooth devices present within a certain range. Device search symbol is activated and message "WAIT..." is displayed for 60 seconds.

The pairing ends automatically when devices are detected within the range and shown in the list on the right.

If Pairing is not successful, "PAIRING LOST. PLEASE EXIT" message will be displayed. Now you can only quit the BLUETOOTH Setting Menu, and then go back in to run a new Pairing procedure.

If Pairing is successful, as soon as Bluetooth devices are detected, their name is displayed in the device list on the right.

The list of devices found within the range during the Pairing stage does not include already paired devices, that are displayed in the list on the left.

If two or more Bluetooth devices have the same name, the list of the devices detected will include two or more labels with the same name.

If one of the devices detected has no name, it is not included in the list of devices detected.

During the search it is possible to scroll through the device list on the right by pressing buttons (1) and (2). In correspondence of the device that is to be paired, select "CONNECT" and press button (4) to pair it.

To quit the Pairing stage, select EXIT and press button (4).

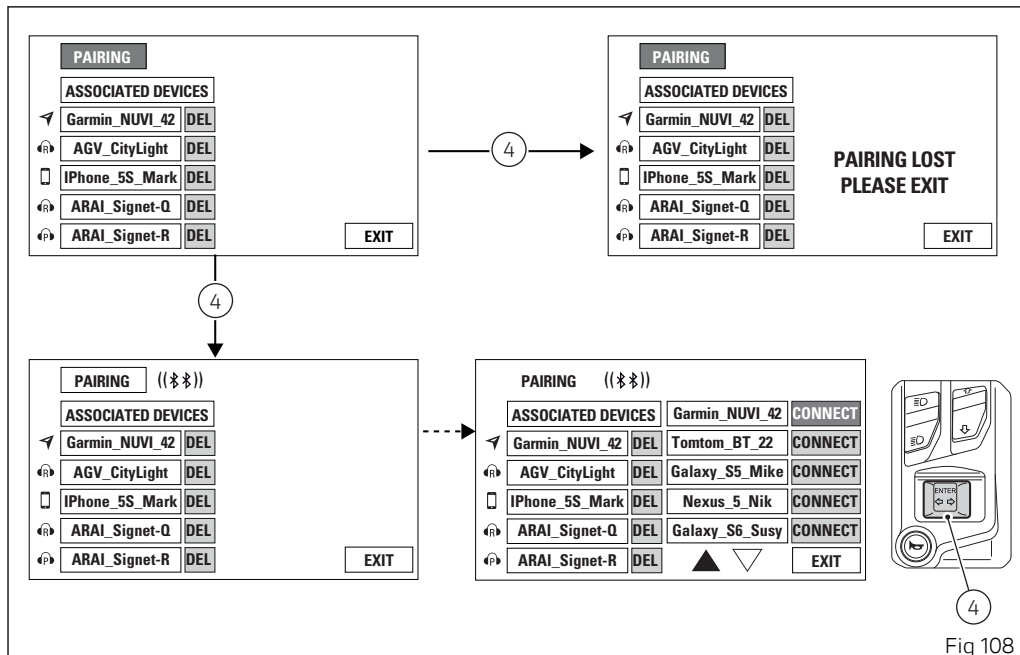

Fig 108

It is possible to pair up to:

- 2 smartphones;
- 1 navigator;
- 1 rider helmet;
- 1 passenger helmet.

If at least 5 devices have already been paired and the user attempts to run the Pairing, the following message will be displayed: "MAX 5 DEVICES CAN BE ASSOCIATED" and "REFER TO USER MANUAL". System automatically highlights DELETE indication for the first associated device and user can delete one or several devices (refer to Deleting associated devices) or quit the Bluetooth Setting Menu, by pressing EXIT.

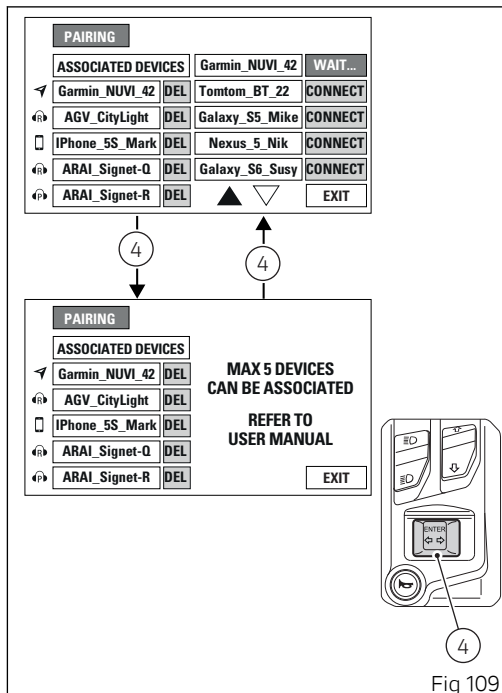

Fig 109

When the device to be paired has been selected, the label in correspondence of that device replaces the word "CONNECTED" with "WAIT" for 60 seconds and it is necessary to select the type of device to be paired. The display shows four icons that represent the available types.

Types of devices can be:

- Smartphone;
- Rider helmet;
- Passenger helmet;
- GPS navigation system.

Use buttons (1) and (2) to select the type and press button (4) to confirm.

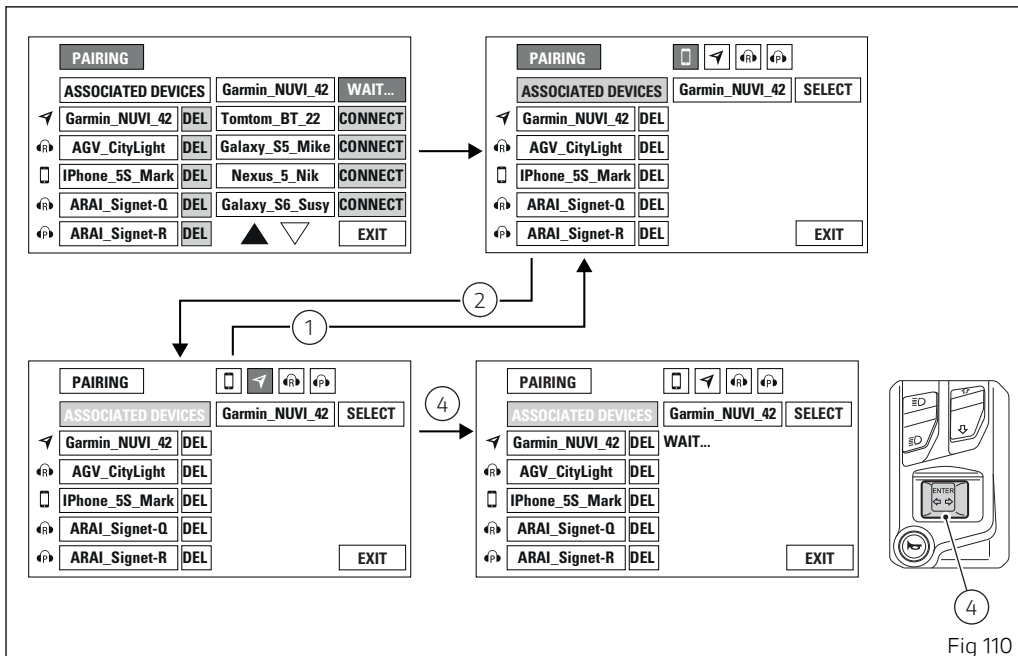

Fig 110

If you wish to pair a Bluetooth Navigator, the pairing procedure is completed on the navigator, by selecting on the latter the connection with the motorcycle Bluetooth control unit.

In this case, during the pairing the display shows the message "CONNECT ON NAVI" that disappears when the connection between the control unit and the navigator is completed, and the name of the navigator is indicated in the list on the left.

Note

If user does not complete the pairing procedure on the Navigator within 90 seconds, pairing screen on instrument panel will go out, and display will go back to Bluetooth Setting Menu main screen.

If the navigator pairing is active for more than 90 seconds and so there have been errors in the procedure, it is not possible to select the detected devices. It is only possible to press on EXIT to abort the procedure if deemed necessary.

Once the pairing is completed, the name of the paired device is shown in the device list on the left: only the first characters of the device name are displayed.

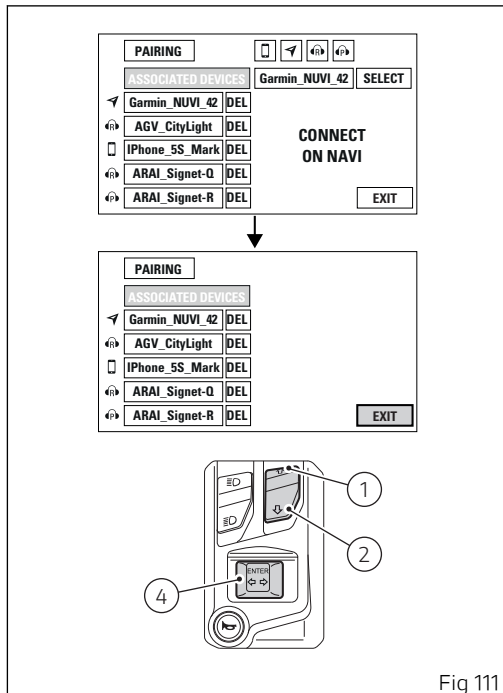

Fig 111

Pairing deactivation takes place when quitting the Bluetooth Setting Menu or when no more Bluetooth devices are detected.

Attention

Ducati does not ensure a correct connection to the Ducati Multimedia System of Bluetooth navigators that are not provided in the following kits:

- Kit of Ducati Zumo satellite navigator 350
- Kit of Ducati Zumo satellite navigator 390
- Kit of Ducati Zumo satellite navigator 395

Note

The Ducati kits mentioned above can be purchased separately at a Ducati Dealer or Authorised Service Centre.

Deleting associated devices

From the Bluetooth setting menu it is possible to access the list of the paired devices on the left. From the list of paired devices, user can select the device to be deleted by pressing button (1) or button (2). When the device is selected and the relevant DEL label is green, press button (4) for at least two seconds to eliminate the device from the paired device list. Select EXIT by pressing button (1) or (2) and pressing button (4) you quit the Bluetooth Setting Menu and go back to the main Setting Menu screen.

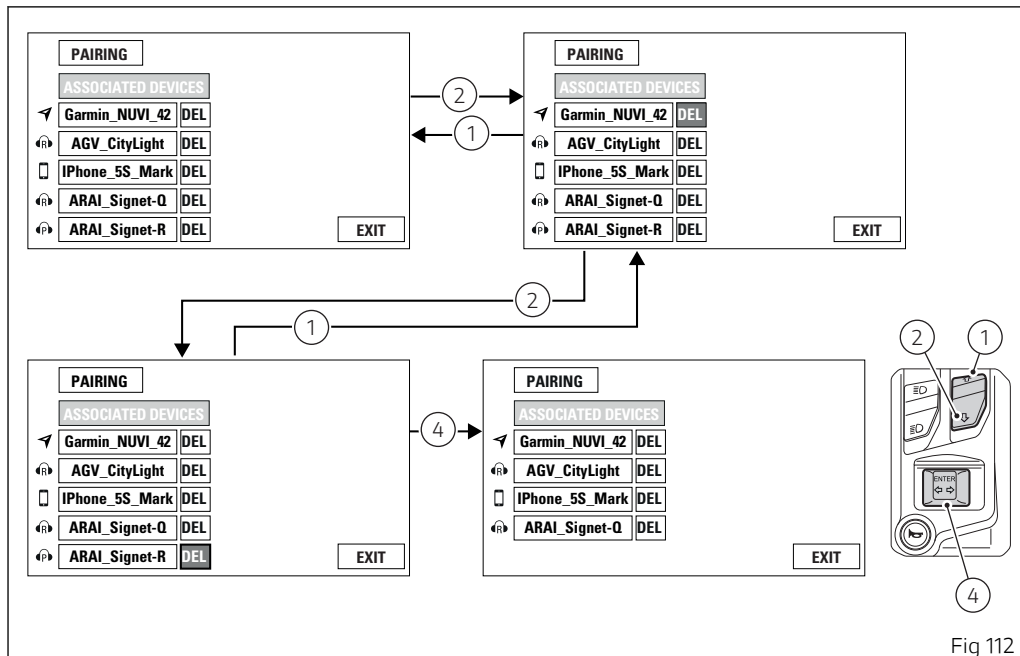

Fig 112

Service information

This Function allows viewing information about the remaining time or mileage until the next Oil Service, Desmo Service and Annual Service.

To view them, enter the Setting Menu, use button (1) or (2) to select SERVICE and press button (4).

Available information:

- OIL SERVICE: indicates the km (or mile) count-down to the next OIL SERVICE;
- DESMO SERVICE: indicates the km (or mile) count-down to the next DESMO SERVICE;
- ANNUAL SERVICE: indicates the ANNUAL SERVICE expiration date.

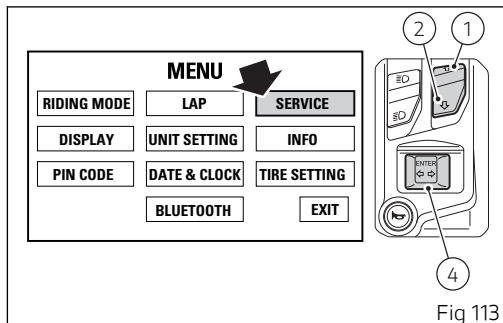

Fig 113

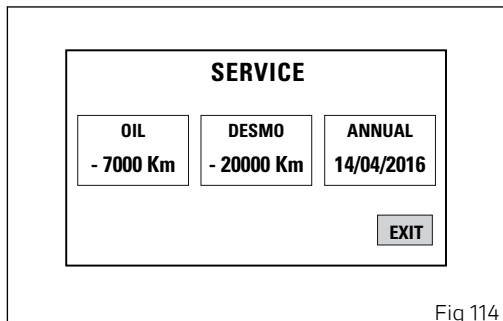

Fig 114

Information (INFO)

This function allows displaying several useful details. To view the "INFO", enter the Setting Menu, use button (1) or (2) to select "INFO" and press button (4). Available information:

- BATTERY (battery voltage);
- RPM (engine rpm indication);
- BLUETOOTH version (optional).

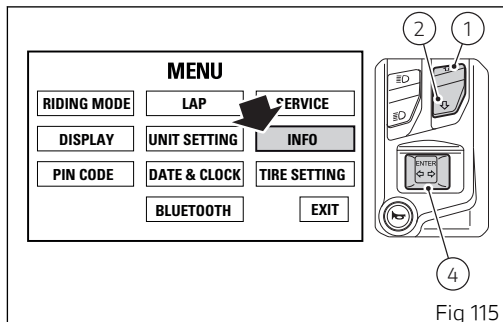

Fig 115

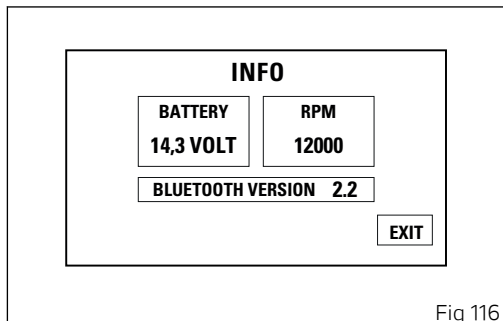

Fig 116

Tire Setting

If owners install different tyres than original equipment ones and yet belonging to the classes specified by Ducati, this function allows them to recalibrate the system. It also allows system correct recalibration of all controls (such as DTC) in case the owner changed front and rear sprocket ratio, so that all motorcycle control systems can consider these changes / variants and adapt their processing parameters accordingly.

From the Setting Menu, it is possible to start the teach-in procedure of the new rolling circumference and new final drive ratio or restore the default settings as established by Ducati for OEM outfit.

To do this, you must enter the Setting MENU.

Select "TIRE SETTING" option, by pressing button (1) or (2). Once function is highlighted, press CONFIRM MENU button (4).

You open the TIRE SETTING Menu.

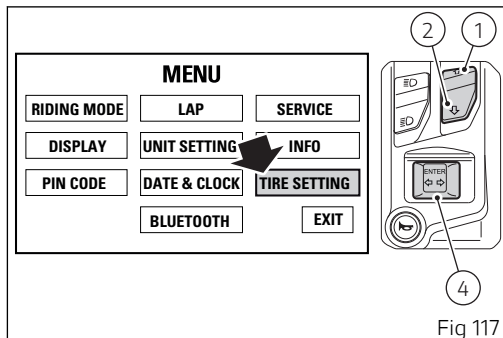

Fig 117

Press buttons (1) and (2) to select START or DEFAULT: the latter can be selected only if the motorcycle is currently not set to the factory default configuration.

To exit the menu and go back to previous page, select EXIT and press button (4).

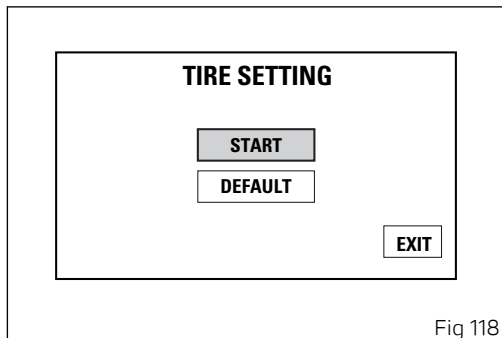

Fig 118

Teach-in procedure

When entering the function, the vehicle speed and gear engaged are indicated on the right, while the instructions on the required speed range and gear to be engaged to correctly carry out the procedure are displayed at the centre.

Speed range: 48 ÷ 52 km/h (and corresponding value in mph if set unit of measurement is mph)

Gear: 2

The first page indicates READY in red at the top of the display to warn the rider that the system is ready for the calibration procedure.

When the rider complies with the required conditions of vehicle speed and gear displayed, system calibration will start and an orange IN PROGRESS message will be displayed at the top.

If procedure is successfully completed, COMPLETED message in green will come on at the top of the display, and after a few seconds it will be automatically replaced with the main screen.

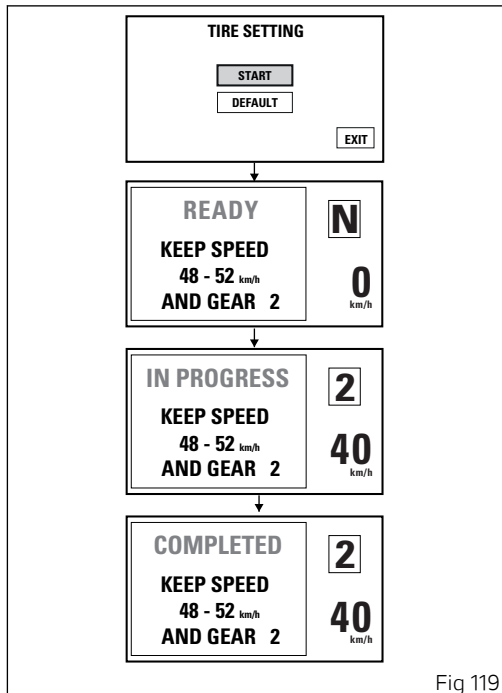

Fig 119

If it is not possible to start the procedure when the START is confirmed, after a few seconds the instrument panel will automatically highlight the option EXIT.

If an error or malfunction occurs during the calibration procedure, FAILED message in red will come on at the top of the display, and after a few seconds it will be automatically replaced with the main screen.

The rider can abort the procedure both during the READY stage and during the IN PROGRESS stage, by pressing button (1) for 2 seconds. ABORTED message in red will come on at the top of the display, and after a few seconds it will be automatically replaced with the main screen.

The values shown in the pictures as required speed range and gear are just an example and shall not be considered as binding or corresponding to the ones actually set for the vehicle.

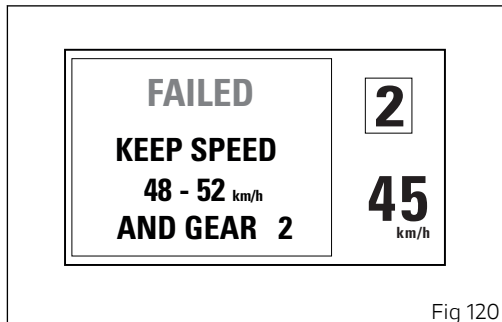

Fig 120

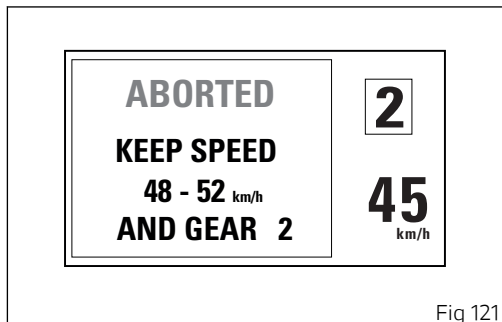

Fig 121

Restoring default settings

Open the TIRE SETTING Menu.

Then use buttons (1) and (2) to select DEFAULT and keep button (4) pressed for 3 seconds.

For a few seconds the message PLEASE WAIT... will be on the display.

If the procedure for restoring the default settings is successful, DEFAULT OK will be displayed for 2 seconds and after a few seconds it will be automatically replaced with the main screen.

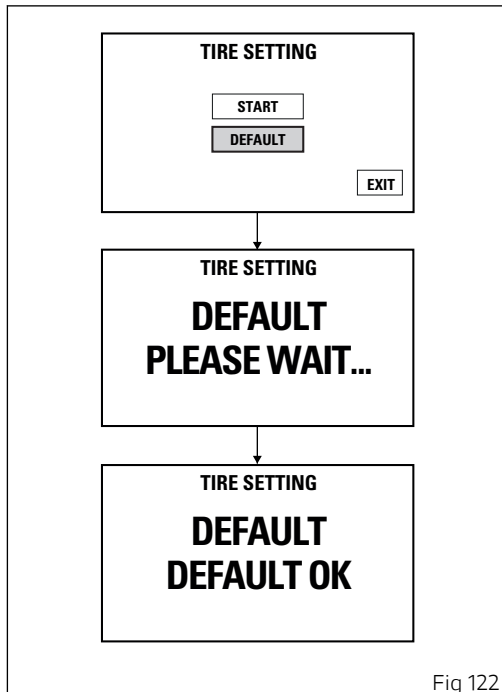

Fig 122

While, if the procedure for restoring the default settings is not successful, ABORTED will be displayed for 2 seconds and then the instrument panel will automatically display the main screen of the TIRE SETTING menu with highlighted EXIT item.

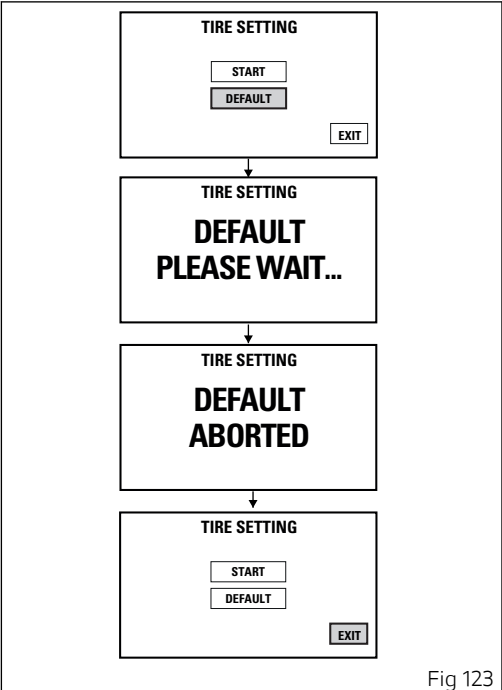

Fig 123

Display backlighting colour

Instrument panel can automatically adjust display background colour based on ambient light. If BACKLIGHT – AUTO function is active, when sensor detects a "low ambient light" (night) it shifts to black background mode (NIGHT); while when a "significant" ambient light (day) is detected, it shifts to white background mode (DAY).

It is possible to customise this function through the Setting Menu, select "BACKLIGHT" and open the "BACKLIGHT" menu:

- permanently set either one of the two modes NIGHT or DAY, or
- set AUTO mode.

Refer to paragraph ("Display backlighting setting" page 127).



Note

If power is above 16 V, backlighting is disabled, while if power is below 8 V, backlighting is turned off.

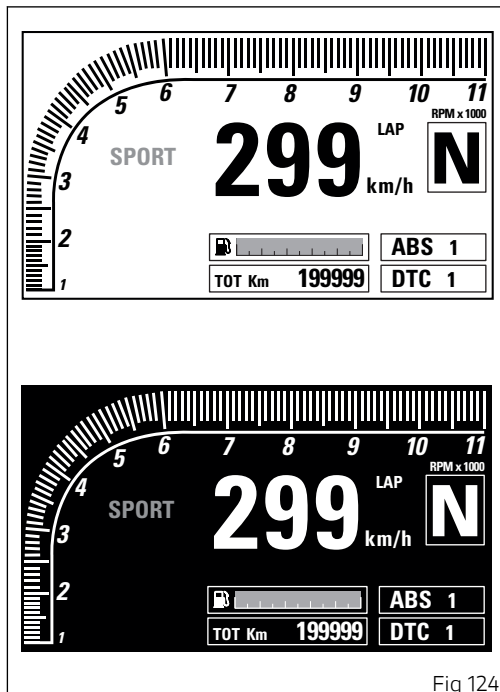

Fig 124

Light control

Low / High beam

At Key-On, the high beam and low beam lights are OFF: only the parking lights are turned on. Once the engine is started, the low beam is automatically turned on; it is possible to switch from low beam to high beam and vice versa by pressing button (7) in positions (B) and (A). If engine is not started upon key-on, it is anyway possible to switch high/low beams on by pushing button (7) positions (B) and (A) on LH switch.

If within 60 seconds from the "manual" switching on of the low / high beam the engine is not started, the lights are disabled again (off).

High/low beam switching-off during vehicle starting

To preserve the motorcycle battery, if when starting the engine the high/low beams are ON, the headlight is automatically switched off and then on again when the engine is started.

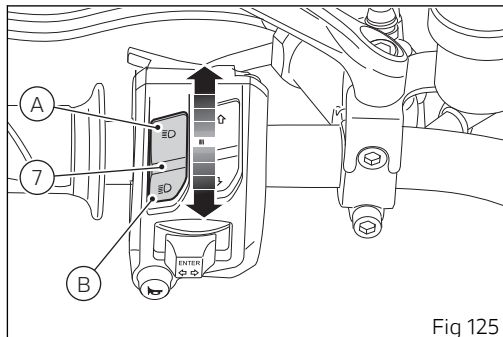

Fig 125

Turn indicators

Turn indicators are automatically reset by the instrument panel.

After activating one of the two turn indicators, user can reset them using the button (4) on the left switch.

If the turn indicator is not reset manually, the instrument panel will automatically switch it off after the motorcycle has travelled 500 m (0.3 miles) from when the turn indicator was activated. The counter for the distance travelled for automatic deactivation is only activated at speeds below 80 km/h (50 mph). If the calculation of the distance for automatic deactivation is activated and then the motorcycle exceeds a speed of 80 km/h (50 mph), the calculation will be interrupted and will restart when the speed returns below the indicated threshold.

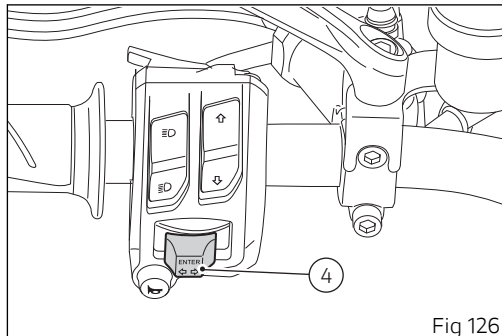

Fig 126

Hazard function (4 turn indicators)

The "Hazard" function turns all four turn indicators on at the same time to signal an emergency condition. Push button (6) to activate the "Hazard" function. Activation is only possible when motorcycle is ON (i.e. when key is turned to "ON" while engine status does not matter). When the "Hazard" function is active, all four turn indicators blink at the same time as well as warning lights (7) on the instrument panel. The "Hazard" function can be disabled both with vehicle on (key turned to "ON") and vehicle off (key turned to "OFF") by pressing button (6).

Once the "Hazard" function is activated, if vehicle is turned off (key turned to "OFF"), the function stays active until manually disabled by the user or for 2 hours. After 2 hours, the turn indicators switch OFF automatically in order to save battery charge.

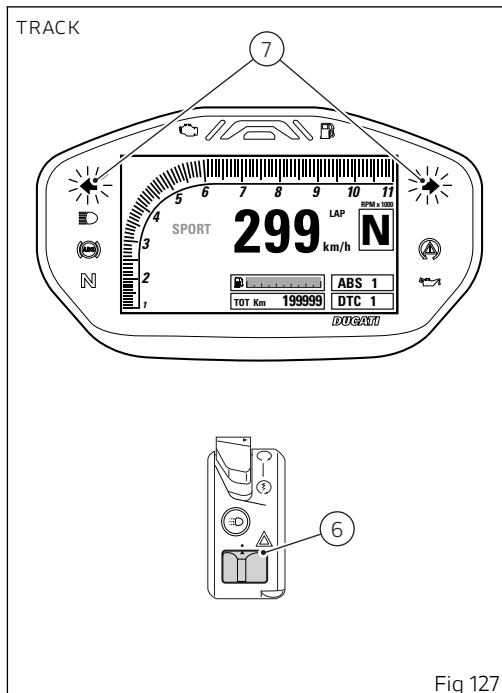

Fig 127

 **Note**

If user performs a Key-ON while the "Hazard" function is still active, the function will remain ON (temporary turn indicator control interruption is allowed during the instrument panel initial check routine).

 **Note**

If there is a sudden interruption in the battery while the function is active, the instrument panel will disable the function when the voltage is restored.

 **Note**

The "Hazard" function has higher priority compared to normal operation of the single turn indicators, this means that, as long as it is active, it will not be possible to activate the single right or left turn indicators.

Immobilizer system

To further improve the anti-theft protection, the motorcycle is equipped with an engine electronic block system (IMMOBILIZER) that is automatically activated every time the instrument panel is switched off.

Inside of each key handgrip there is an electronic device that modulates the signal sent by a special antenna integrated in the ignition switch upon starting.

Such modulated signal represents the "password", that changes upon every starting, that allows the control unit to acknowledge the key and thus starting the engine.

Keys

The motorcycle comes with 2 keys.

They contain the "Immobilizer system code".

Keys (B) are those for the standard use, i.e. to:

- start the engine;
- open the fuel tank plug;
- open the seat lock.



Attention

Separate the keys and use only one of the two to ride the bike.

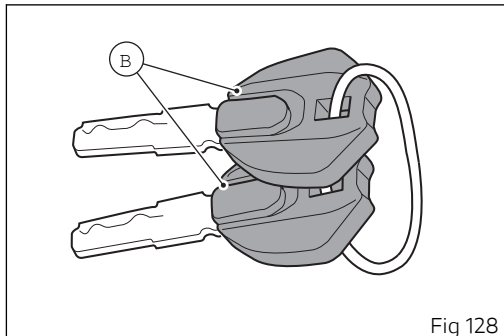

Fig 128

Operation

Every time you turn the key from ON to OFF, the protection system activates the engine block. If also in this case you are not able to start the engine, contact an authorised Ducati service centre.



Attention

Strong impacts could damage the electronic components inside the key. During the procedure always use the same key. Using different keys may prevent the system from acknowledging the code of the inserted key.

Key duplication

When a customer needs spare keys, he/she shall contact a Ducati authorised service centre and bring all keys he/she still has.

The Ducati authorised service centre will program all new and old keys.

The Ducati authorised service centre may ask to the customer to prove to be the motorcycle owner.

The codes of the keys missing during the programming procedure will be erased to ensure that any lost key can not start the engine.



Note

If the motorcycle owner changes, it is necessary that the new owner is given all keys.

Restoring motorcycle operation via the PIN CODE

In case of key acknowledgement system or key malfunction, the instrument panel allows the user to enter his/her own PIN code to temporarily restore motorcycle operation.

If the PIN CODE function is not active, the instrument panel does not activate the page for entering the release code, but shows the Standard screen instead, triggers the E-LOCK error to inform the user that there is a problem with key reading/ acknowledgement and disables the opportunity to enter the Setting Menu.

The E-LOCK error warning must remain active until next Key-OFF.

If the PIN CODE function is active, the instrument panel activates the page for entering the release code and displays the message INSERT PIN CODE with a string of four green dashes " - - - - " under it.

Entering the code:

- 1) Press button (4), only one digit indicating "0" turns green;
- 2) each time you press the button (2) the displayed number increases by one (+ 1) up to "9" and then starts back from "0";
- 3) each time you press the button A (1) the displayed number decreases by one (- 1) up to "1" and then starts back from "0";
- 4) to confirm the number, press the button (4).

Repeat the procedures until you confirm all the 4 digits of the PIN CODE.

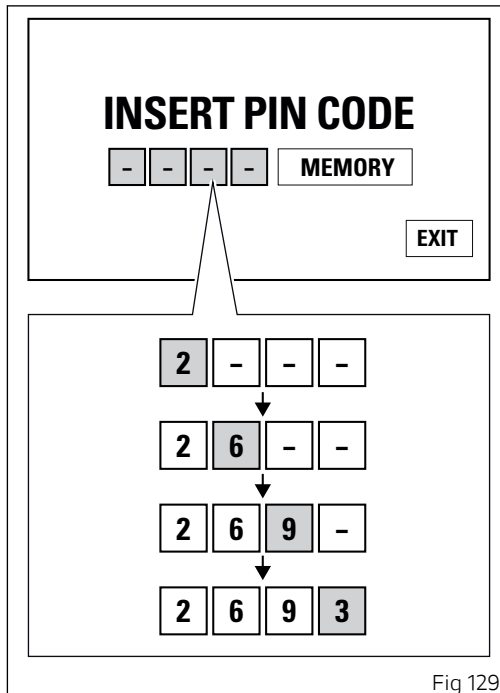

Fig 129

When you press button (4) to confirm the fourth and last digit:

- if the PIN code is not correct, the instrument panel displays **WRONG** for 3 seconds and then highlights the string of four dashes "----" to allow you to try again. The number of possible attempts is determined by a preset time-out of 2 minutes. After this time, the instrument panel shows the Standard screen, triggers the E-LOCK error and disables the opportunity to enter the Setting Menu.
- If there is a problem during the PIN CODE check, the instrument panel displays **ERROR** for 3 seconds and then responds in the same way as for the **WRONG** error.
- If the PIN code is correct, the instrument panel displays **CORRECT** for 3 seconds and then shows the "Standard screen" and triggers the E-LOCK error to still show the user that there is a problem with key reading/acknowledgement.

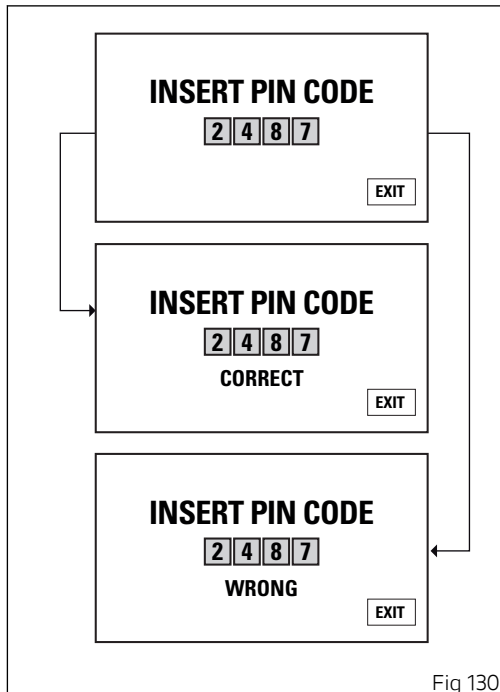

Fig 130



Important

If this procedure is necessary in order to start the motorcycle, contact an Authorised Ducati Service Centre as soon as possible to fix the problem.

Controls

Position of motorcycle controls



Attention

This section shows the position and function of the controls used to ride the motorcycle. Be sure to read this information carefully before you use the controls.

- 1) Instrument panel.
- 2) Key-operated ignition switch and steering lock.
- 3) Left-hand switch.
- 4) Clutch lever.
- 5) Right-hand switch.
- 6) Throttle twistgrip.
- 7) Front brake lever.
- 8) Gear change pedal.
- 9) Rear brake pedal.

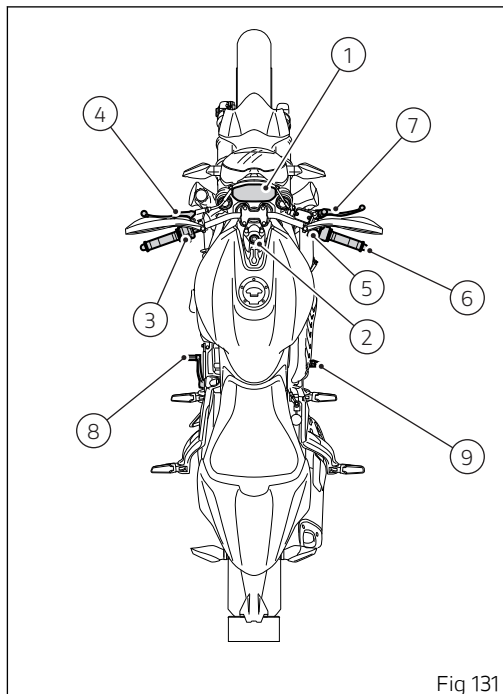

Fig 131

Ignition switch and steering lock

It is located in front of the fuel tank and has four positions:







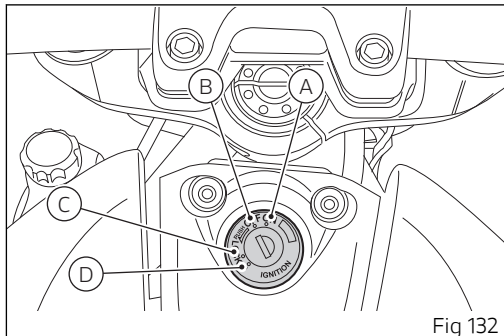

- A) ON: enables lights and engine operation;
- B) OFF: disables lights and engine operation;
- C) LOCK: the steering is locked;
- D) P: parking light and steering lock.

Note

To move the key to the last two positions, press it down before turning it. The key can be removed in positions (B), (C) and (D).



Left-hand switch

- 1) (FLASH) button, "Start-Stop lap" function.
- 2) 2-position light switch:
 - high beam ()
 - low beam ();
- 3) Menu navigation buttons:
 - menu  (UP)
 - menu  (DOWN);
- 4) Menu button (ENTER) / 3-position turn indicator switch ():
 - centre position = OFF
 - position  = left turn
 - position  = right turn
 - pressed = menu confirmation (ENTER);
- 5) Warning horn button ().

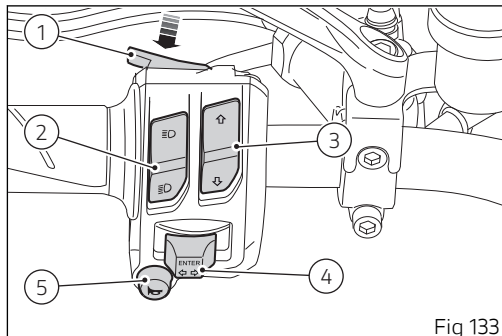

Fig 133

Clutch lever

Lever (1) disengages the clutch. When the clutch lever (1) is operated, drive from the engine to the gearbox and the drive wheel is disengaged. Using the clutch properly is essential to smooth riding, especially when moving OFF.



Important

Using the clutch properly will avoid damage to transmission parts and spare the engine.



Note

The engine can be started with the side stand down and the gearbox in neutral. If starting with a gear engaged, pull in the clutch lever (in this case the side stand must be up).

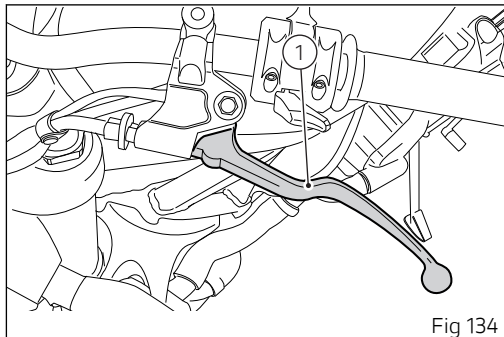

Fig 134

Clutch control free play adjustment

Attention

A wrong adjustment can seriously affect the clutch operation and service life.

A worn clutch tensions the clutch cable.

Always check the free play, with cold engine, before using the vehicle.

When operating the clutch lever, you must clearly feel the passage from a very low resistance to a very high resistance (operating force).

The free play corresponds to the lever travel where the clutch resistance force is very low.

To check the free play operate the lever for its free play and check that distance "A" is between 3 - 4 mm (0.12 - 0.16 in).

To adjust the free play to the recommended value work on the primary adjuster (2) close to the clutch control.

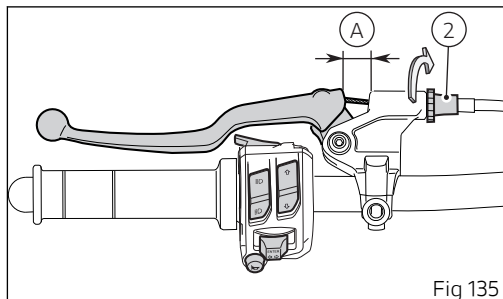

Fig 135

Adjuster (2), located on the lever, allows a maximum adjustment (Q) of 11 mm (0.4 in), whereas the standard adjustment (starting one) is of 5 mm (0.2 in). If working such adjuster proves insufficient, work the secondary adjuster (3) on vehicle RH side.

Attention

In case of a slipping clutch due to clutch wear, adjuster (2) on the lever must NEVER be loosened, but screwed, as described above. If the clutch is still slipping, go to a Dealer or a Ducati authorised service centre.

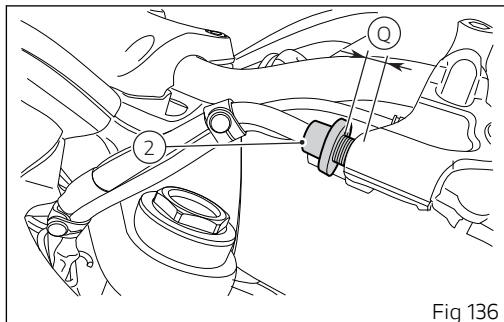

Fig 136

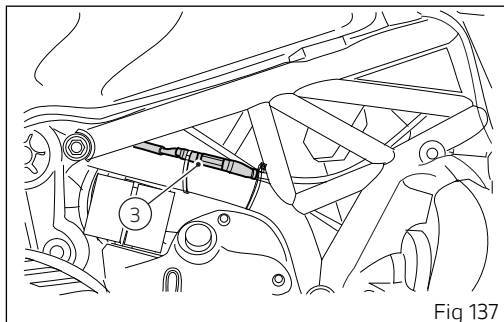

Fig 137

Right-hand switch

- 1) Red ON/OFF switch.
- 2) Hazard button.

The switch (1) has three positions:

- position up: KILL ENGINE;
- central position: ENGINE ENABLING;
- pushed down: ENGINE START.

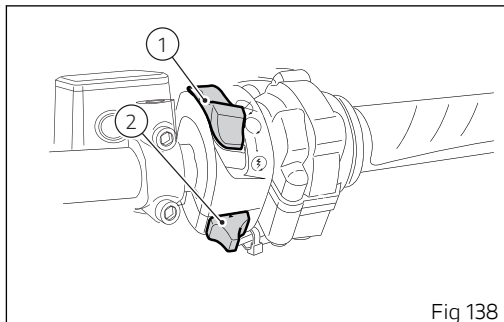

Fig 138

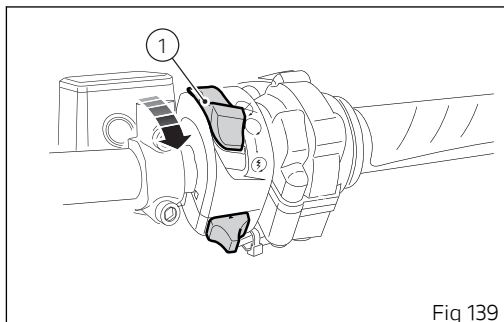

Fig 139

Throttle twistgrip

The twistgrip (1) on the right handlebar opens the throttles.

When released, it will spring back to the initial position (idling speed).

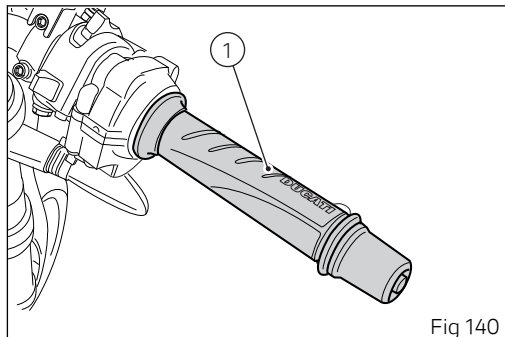

Fig 140

Front brake lever

Turn knob (2) clockwise/counter clockwise to adjust lever (1) distance from handgrip.



Attention

Before using these controls, thoroughly read instructions under "Moving off".



Attention

Set front brake lever when motorcycle is stopped.

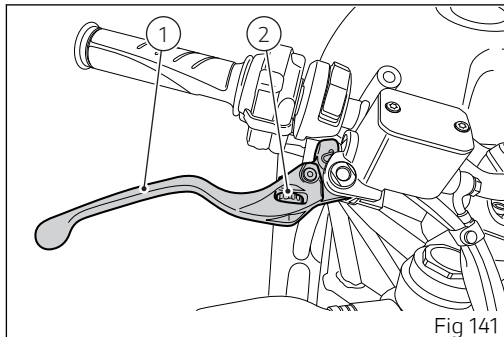

Rear brake pedal

Press pedal (1) down with your foot to operate the rear brake.

The control system is of the hydraulic type.

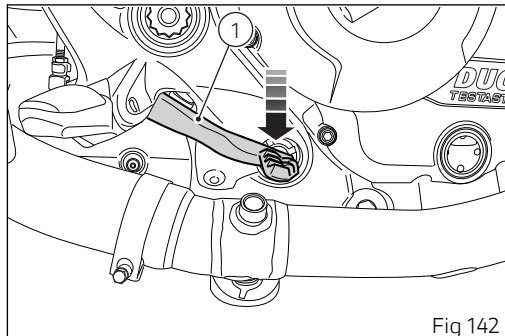

Fig 142

Gear change pedal

The gear change pedal can move in the following two directions and, when released, it automatically returns to rest position N in the centre:

- down = press down the pedal to engage the 1st gear and to shift down. The N light on the instrument panel will go out.
- upwards= lift the pedal to engage 2nd gear and then 3rd, 4th, 5th and 6th gears.

Each time you move the pedal you will engage the next gear.

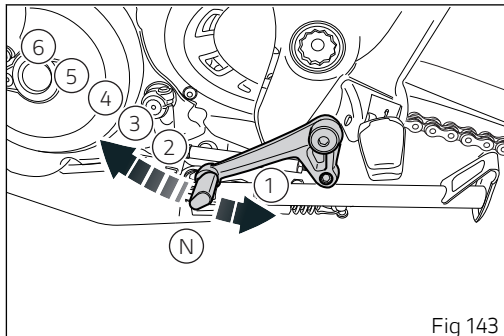

Fig 143

Adjusting the position of the gearchange pedal and rear brake pedal

Gear change pedal

The position of the gearchange and rear brake levers in relation to the footpegs can be adjusted to suit the requirements of the rider.

To adjust the position of the gear shift lever, proceed as follows: hold the linkage (1) and slacken the lock nuts (2) (3/8" flat) and (3) (3/8" flat).

Note

Nut (2) has a left-hand thread.

Fit an open-end wrench to flat (A) and rotate linkage (1) until setting pedal in the desired position.
Tighten both lock nuts onto linkage (5 Nm).

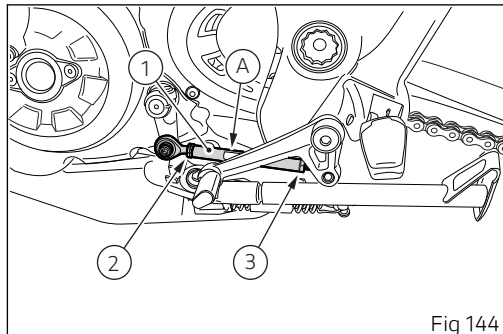

Rear brake pedal

To adjust the position of the rear brake pedal, loosen lock nut (4), turn pedal stroke adjuster screw (5) until obtaining the required position. Tighten the lock nut (4) (2.3 Nm).

Operate the pedal by hand to check that there is 1.5 to 2 mm (0.06÷0.08 in) of free play before the brake bites.

If not, adjust the length of the master cylinder control rod as follows.

Loosen lock nut (6) on master cylinder rod.

Tighten rod on fork (7) to increase clearance or loosen it to decrease it.

Tighten lock nut (6) (7.5 Nm) and check play again. Check for proper operation of the stop sensor.

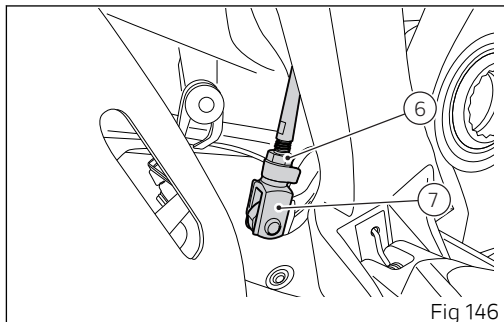
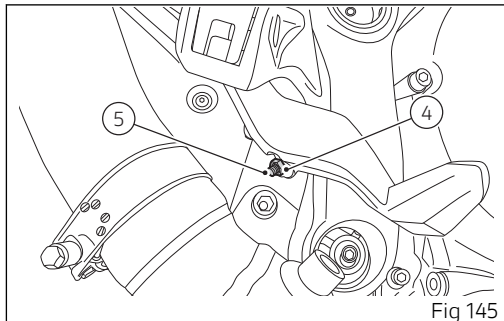

Main components and devices

Position on the vehicle

- 1) Tank filler plug.
- 2) Seat lock.
- 3) Helmet cable fastening pin.
- 4) Side stand.
- 5) Rear-view mirrors.
- 6) Rear shock absorber adjusters.
- 7) Catalytic converter.
- 8) Exhaust silencer.

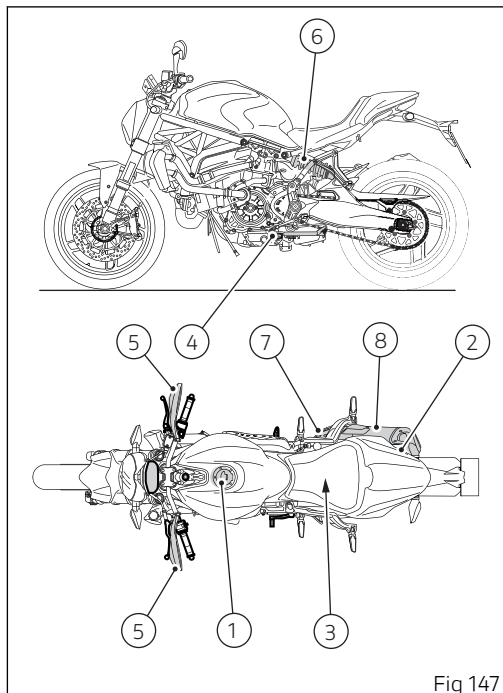

Fig 147

Tank filler plug

OPENING

Lift flap (1) and insert the key in the lock. Turn the key clockwise by 1/4 of a turn to release the lock.

CLOSING

Close the plug with key inserted and press to fit in place. Turn the key counter clockwise to the original position and remove it. Close flap (1).



Note

Plug can only be closed when key is inserted.



Attention

After refuelling, always make sure that the plug is perfectly in place and closed.

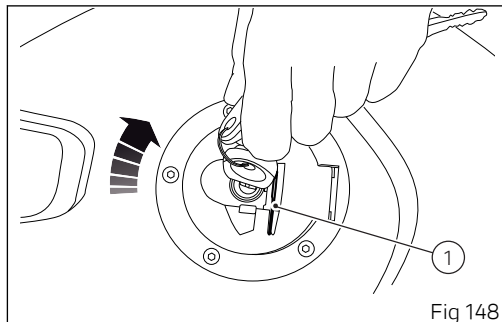

Fig 148

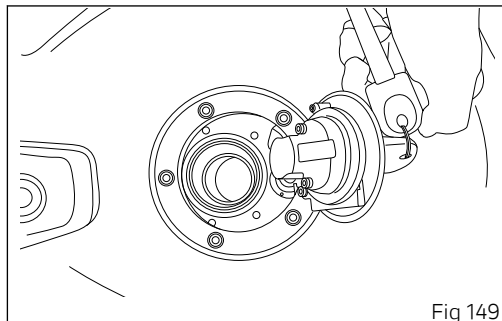

Fig 149

Seat lock

OPENING

Insert the key in lock (1), turn clockwise while pressing down at the latch to help release the pin. Remove the seat (2) pulling it backwards until sliding it out of the front retainers.

CLOSING

Make sure that all elements are correctly positioned and fastened to the compartment under the seat (2). Engage seat bottom front tabs (A) on tank bracket (B) fastened to rear subframe. Hold seat rear end lifted, push on the central fastener to engage it: push on seat rear end until latch clicks in place. Make sure the seat is safely secured to the frame and remove the key from the lock.

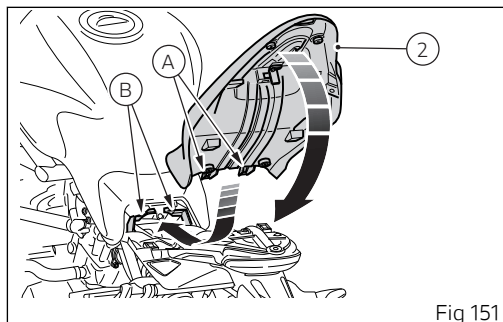
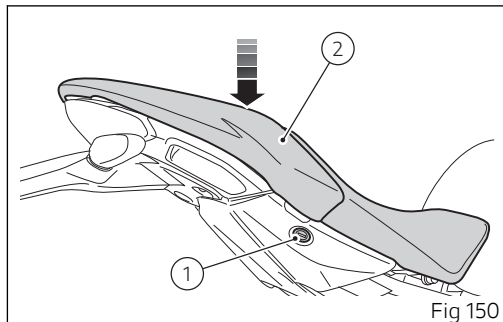

Seat height adjustment

The motorcycle is sold with raised seat. Seat height can be lowered.

To lower the seat (1), remove it together with the relevant cover.

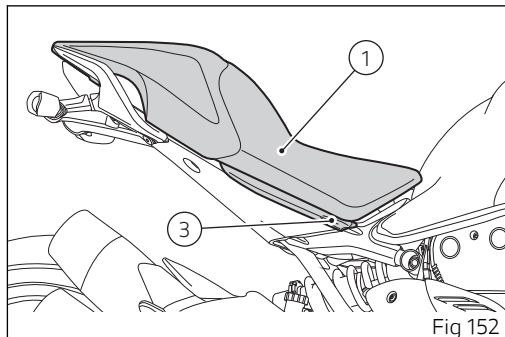

Remove the four blocks (4) located under the seat (1).
Position hook (5) with elastic band in the bottom
retainer.

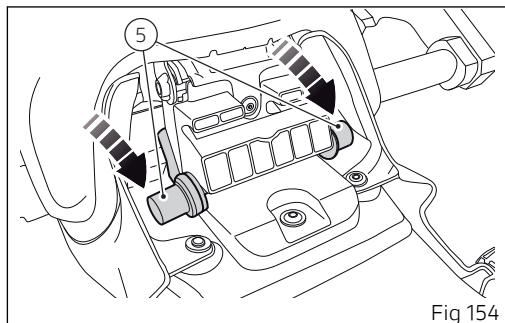
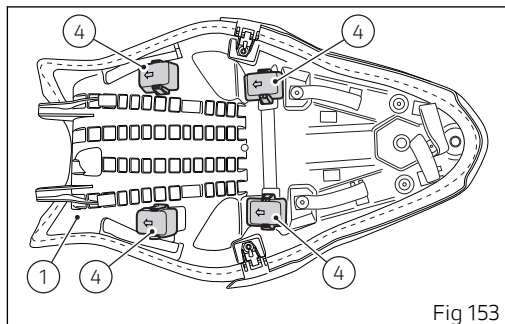

Fit the seat with its cover on the motorcycle. Now the seat is in a lowered position.

To raise the seat (1), remove it together with the relevant cover.

Fit the four blocks (4) in their housing under seat (1).

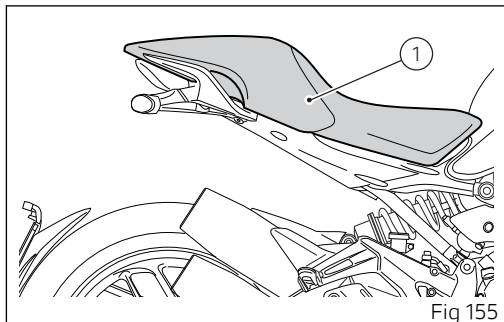

Fig 155

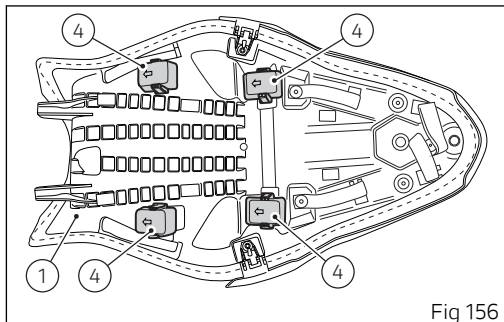
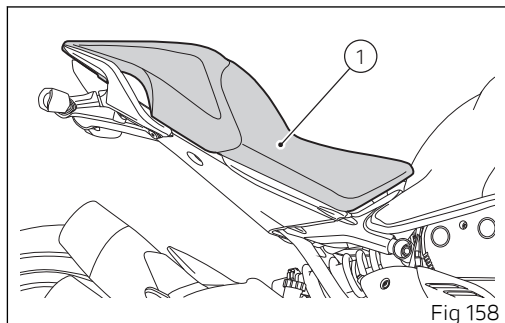
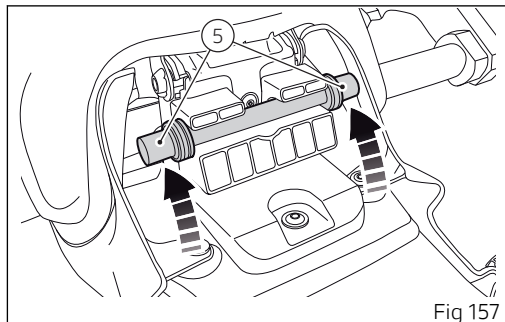

Fig 156

Position hook (5) with elastic band in the top retainer.
Refit the seat with its cover on the motorcycle.



Helmet cable

The helmet cable (1) is inside the tool box, refer to "Tool kit and accessories" page 232. Route cable through helmet and engage cable end into pin (2). Leave the helmet hanging and refit the seat to hold it in place.



Attention

This device protects the helmet against theft when the motorcycle is parked. Do not leave the helmet attached when riding the motorcycle; it could interfere with your movements and cause loss of control of the motorcycle.

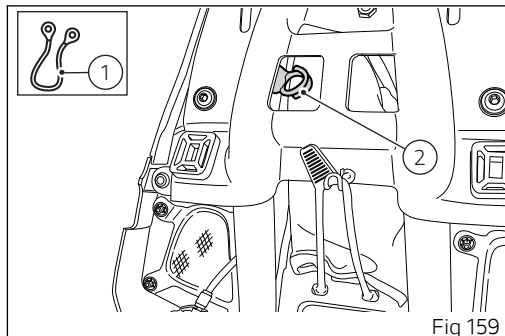

Side stand

Important

Place the motorcycle on the side stand only when you are not going to use it for short periods of time. Before lowering the side stand, make sure that the bearing surface is hard and flat.

Do not park on soft or pebbled ground or on asphalt melt by the sun heat and similar or the motorcycle may fall over.

When parking downhill, always position the motorcycle with the rear wheel facing downhill. To pull down the side stand, hold the motorcycle handlebar with both hands and push down on the side stand (1) with your foot until it is fully extended. Tilt the motorcycle until the side stand is resting on the ground.

To move the side stand to its rest position (horizontal position), lean the motorcycle to the right while lifting the thrust arm (1) with your foot.

To ensure trouble-free operation of the side stand joint, thoroughly clean it and then use SHELL Alvania R3 grease to lubricate all friction points.

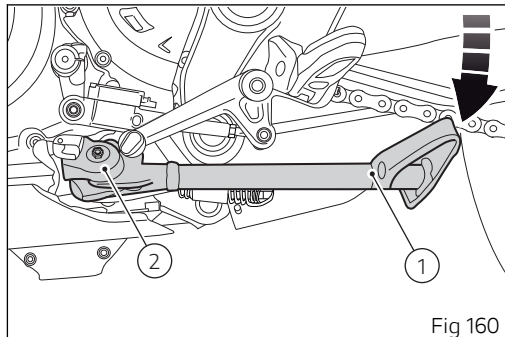

Note

Check for proper operation of the stand mechanism (two springs, one into the other) and the safety sensor (2) at regular intervals.



Note

The engine can be started with the side stand down and the gearbox in neutral. If starting with a gear engaged, pull in the clutch lever (in this case the side stand must be up).

Rear shock absorber adjusters

The rear shock absorber has external adjusters that enable you to adjust the setting to suit the load on the motorcycle.

The adjuster (1) located on the left side, on the upper connection holding the shock absorber to the engine, adjusts the damping during the rebound phase (return).

Turn adjuster (1) clockwise to stiffen the damping, or counter clockwise to soften it.

Ring nuts (2) and (3), located in the shock absorber lower side, adjust the external spring preload.

To change spring preload, slacken the lower locking ring nut (3). Then **TIGHTEN** or **SLACKEN** the upper ring nut (2) to **INCREASE** or **DECREASE** spring preload.

After setting spring preload as desired, tighten the lower locking ring nut (3).

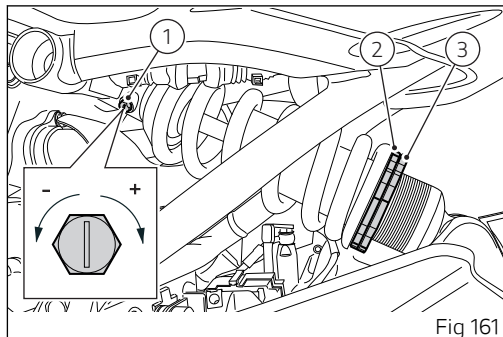

Fig 161

STANDARD setting from the fully closed position (clockwise):

- rebound: loosen adjuster (1) by 1.5 turns (from fully closed position);
- spring preload: 15 mm (0.59 in) (from fully uncompressed).



Attention

To turn the preload adjuster ring nut use a pin wrench. Pay attention to avoid hand injuries by hitting motorcycle parts in case the wrench tooth suddenly slips on the ring nut groove while moving it.



Attention

The shock absorber is filled with gas under pressure and may cause severe damage if taken apart by unskilled persons.

SETTING THE SUSPENSIONS

The values in the table are indicative. They have been calculated considering a dressed rider weighing 80–90 kg (176.37–198.41 lb) and a dressed passenger weighing 70–80 kg (154.32–176.37 lb).

Adjusting the rear shock absorber					
Parameter	Range	Default	Sport	Comfort	Rider + passenger
Compression	–	–	–	–	–
Rebound	0 ÷ 5 turns	1.5 turns	0.5 turns	2.5 turns	1.5 turns
Spring preload	10 ÷ 20 mm (0.39÷0.79 in)	15 mm (0.59 in)	15 mm (0.59 in)	15 mm (0.59 in)	19 mm (0.75 in)

Riding the motorcycle

Running-in recommendations

Important

Before using the motorcycle, check for no labels on the rear-view mirrors; otherwise remove them.

Maximum rotation speed

Rotation speed for running-in period and during standard use (rpm):

- 1) up to 1,000 km (621.37 mi);
- 2) from 1000 km (621.37 mi) to 2500 km (1553.42 mi).

Up to 1,000 km (621.37 mi)

During the first 1000 km (621.37 mi), keep an eye on the rev counter. It should never exceed: 5,500÷6,000 rpm.

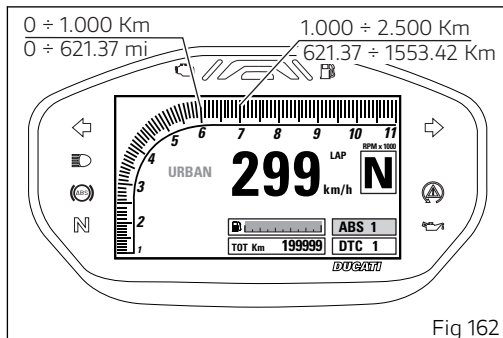

Fig 162

During the first hours of riding, it is advisable to run the engine at varying load and rpm, though still within recommended limit.

To this end, roads with plenty of bends and even slightly hilly areas are ideal for a most efficient running-in of engine, brakes and suspensions. For the first 100 km (62.13 mi) use the brakes gently. Avoid sudden or prolonged braking. This will allow the friction material on the brake pads to bed in against the brake discs.

For all mechanical parts of the motorcycle to adapt to one another and above all not to adversely affect

the life of basic engine parts, it is advisable to avoid harsh accelerations and not to run the engine at high rpm for too long, especially uphill.

Furthermore, the drive chain should be inspected frequently. Lubricate as required.

From 1000 km (621.37 mi) to 2500 km (1553.42 mi).

At this point, you can squeeze some more power out of your engine. However never exceed 7,000 rpm.



Important

During the whole running-in period, the maintenance and service rules recommended in the Warranty Card should be observed carefully. Failure to follow these instructions releases Ducati Motor Holding S.p.A. from any liability whatsoever for any engine damage or shorter engine life.

Strict observance of running-in recommendations will ensure longer engine life and reduce the likelihood of overhauls and tune-ups.

Pre-ride checks



Attention

Failure to carry out these checks before riding, may lead to motorcycle damage and injury to rider and passenger.

Before riding, perform a thorough check-up on your motorcycle as follows:

- **FUEL LEVEL IN THE TANK**
Check the fuel level in the tank. Fill tank if needed (page 0).
- **ENGINE OIL LEVEL**
Check oil level in the sump through the sight glass. Top up if needed (page 268).
- **BRAKE FLUID**
Check fluid level in the relevant reservoirs (page 235).
- **COOLANT**
Check coolant level in the expansion reservoir. Top up if needed (page 233).
- **TYRE CONDITION**
Check tyre pressure and condition (page 265).

- **CONTROLS**
Work the brake, clutch, throttle and gear change controls (levers, pedals and twistgrip) and check for proper operation.
- **LIGHTS AND INDICATORS**
Make sure lights, indicators and horn work properly. Replace any burnt-out bulbs (page 262).
- **KEY LOCKS**
Ensure that tank filler plug (page 208) and seat (page 209) are properly locked.
- **STAND**
Make sure side stand operates smoothly and is in the correct position (page 215).

ABS LIGHT

After Key-ON, the ABS light (9, stays ON when the motorcycle speed exceeds 5 km/h (3.10 mph); the warning light switches OFF to indicate the correct operation of the ABS system.



Attention

In case of malfunction, do not ride the motorcycle and contact a Ducati Dealer or authorised Service Centre.

ABS DEVICE

Check that the front (1) and rear (2) phonic wheels are clean.

Attention

Clogged reading slots would compromise system proper operation. It is recommended to disable ABS system in case of muddy road surface because under this condition the system might be subject to sudden failure.

Attention

Prolonged wheelies could deactivate the ABS system.

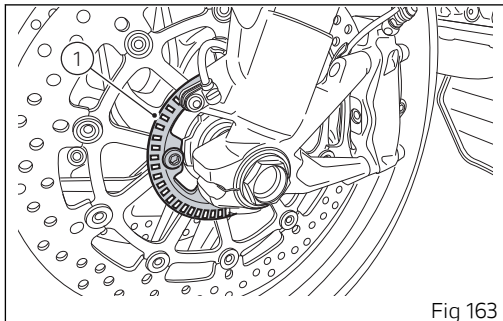

Fig 163

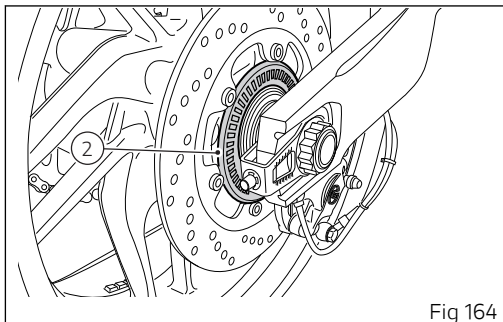

Fig 164

Engine start

Attention

Before starting the engine, become familiar with the controls you will need to use when riding.

Attention

Never start or run the engine indoors. Exhaust gases are poisonous and may lead to loss of consciousness or even death within a short time.

Move the ignition switch to (1, Fig 165). Make sure both the green light N and the red light  on the instrument panel come on.

Important

The oil pressure light should go out a few seconds after the engine has started.

Attention

The side stand must be fully up (in a horizontal position) as its safety sensor prevents engine starting when down.

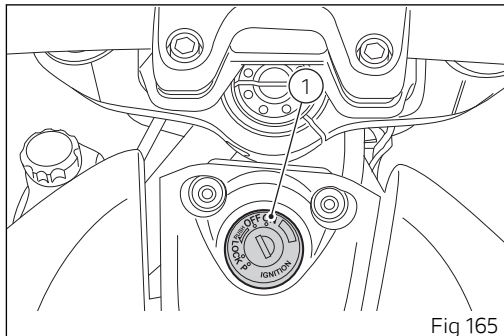



Fig 165

Note

It is possible to start the engine with side stand down and the gearbox in neutral. When starting the motorcycle with a gear engaged, pull the clutch lever (in this case the side stand must be up).

Check that the stop switch (2, Fig 166) is positioned to  (RUN), then press the starter button (3, Fig 166).

Let the motorcycle start without operating the throttle control.

 **Note**

If the battery is flat, system automatically inhibits starter motor cranking operation.

 **Important**

Do not rev up the engine when it is cold. Allow some time for oil to be heated and reach all points that need lubricating.

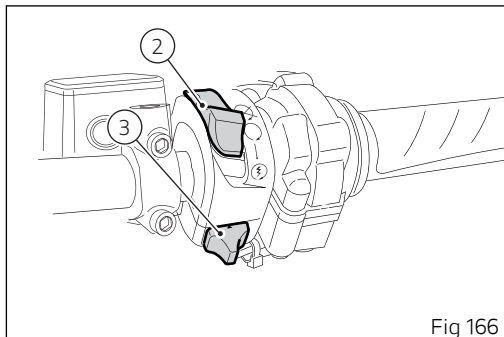

Fig 166

Moving off

- 1) Squeeze the control lever to disengage the clutch.
- 2) Push down on gear change lever sharply with the tip of your foot to engage the first gear.
- 3) Speed up the engine by turning the throttle twistgrip while gradually releasing the clutch lever; the motorcycle will start moving off.
- 4) Let go of clutch lever and speed up.
- 5) To shift up, close the throttle to slow down engine, disengage the clutch, lift the gear change lever and let go of clutch lever.

To shift down, proceed as follows: release the twistgrip, pull the clutch lever, shortly speed up to help gears synchronise, shift down (engage next lower gear) and release the clutch.

The controls should be used correctly and timely: when riding uphill do not hesitate to shift down as soon as the motorcycle tends to slow down, so you will avoid stressing the engine and the motorcycle abnormally.



Attention

Avoid harsh acceleration, as this may lead to misfiring and transmission snatching. The clutch lever should not be held in longer than necessary after a gear is engaged, otherwise friction parts may overheat and wear out.



Attention

Prolonged wheelies could deactivate the ABS system.

Braking

Slow down in time, shift down to use engine brake and then brake by operating both front and rear brakes. Pull the clutch before the motorcycle stops to avoid engine from suddenly stalling.

Anti-Lock Braking System (ABS)

Using the brakes correctly under adverse conditions is the hardest – and yet the most critical – skill to master for a rider. Braking is one of the most difficult and dangerous moments when riding a two wheeled motorcycle: the possibility of falling or having an accident during this difficult moment is statistically higher than any other moment. A locked front wheel leads to loss of traction and stability, resulting in loss of control.

The Anti-Lock Brake System (ABS) has been developed to enable riders to use the motorcycle braking force to the fullest possible amount in emergency braking or under poor pavement or adverse weather conditions.

ABS uses hydraulics and electronics to limit pressure in the brake circuit when a special sensor mounted to the wheel informs the electronic control unit that the wheel is about to lock up.

This avoids wheel lockup and preserves traction. Pressure is raised back up immediately and the control unit keeps controlling the brake until the risk of a lockup disappears.

Normally, the rider will perceive ABS operation as a harder feel or a pulsation of the brake lever and pedal.

The front and rear brakes use separate control systems, meaning that they operate independently. Likewise, the ABS is not an integral braking system and does not control both the front and rear brake at the same time.

If desired, the system can be deactivated from the instrument panel, using the function "Customising Riding Modes: ABS setting" (see page 112).



Attention

When ABS is disabled, the motorcycle restores the standard brake system features; using the two brake controls separately reduces the motorcycle braking efficiency. Never use the brake controls harshly or suddenly as you may lock the wheels and lose control of the motorcycle. When riding in the rain or on slippery surfaces, braking will become less effective. Always use the brakes very gently and carefully when riding under these conditions. Any sudden manoeuvres may lead to loss of control. When tackling long, high-gradient downhill road tracts, shift down gears to use engine braking. Apply one brake at a time and use brakes sparingly. Keeping the brakes applied all the time would cause the friction material to overheat and reduce braking power dangerously. Underinflated tyres reduce braking efficiency, handling accuracy and stability in a bend.

Stopping the motorcycle

Reduce speed, shift down and release the throttle twistgrip.

Shift down to engage first gear and then neutral.

Apply the brakes and bring the motorcycle to a complete stop.

To switch the engine off, simply turn the key to position (2).

Important

Do not leave the key to ON, position (1), with engine off in order to avoid damaging any electrical components.

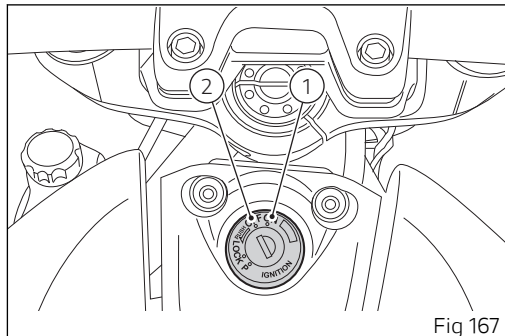

Fig 167

Refuelling

Never overfill the tank when refuelling. Fuel should never be touching the rim of filler recess.

Warning

The fuel pressure inside the tank may, in extreme cases, cause fuel to "spray" when opening the fuel cap.

Always open the fuel cap slowly and carefully during the refill.

If you hear an audible hiss from the cap while opening it, wait until the stop of the hissing before opening it completely.

The sound is residual pressure escaping from the fuel tank, therefore the stop of the hiss indicates that there is no more residual pressure.

The situation described above is more likely in hot weather conditions.

Attention

Use fuel with low lead content and an original octane number of at least 95.

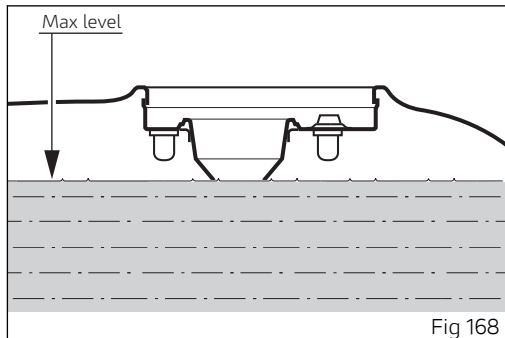

Attention

The motorcycle is only compatible with fuel having a maximum content of ethanol of 10% (E10). Using fuel with ethanol content over 10% is forbidden. Using it could result in severe damage of the engine and motorcycle components. Using fuel with ethanol content over 10% will make the warranty null and void.

Fuel label

The label in figure identifies the fuel recommended for this vehicle.

- 1) The E5 reference inside the label indicates the use of fuel with a maximum oxygen content of 2.7% by weight and a maximum ethanol content of 5% by volume, according to EN 228.
- 2) The E10 reference inside the label indicates the use of fuel with a maximum oxygen content of 3.7% by weight and a maximum ethanol content of 10% by volume, according to EN 228.

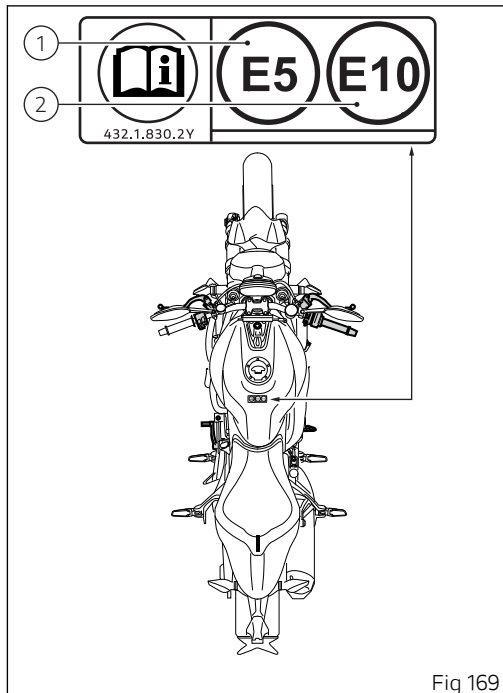

Fig 169

Parking

Stop the motorcycle, then put it on the side stand (page 215).

To prevent theft, turn the handlebar fully left and turn the ignition key to position (3).

If you park in a garage or other indoor area, make sure that there is proper ventilation and that the motorcycle is not near a source of heat.

If required, turn the key to position (4) to leave the parking lights on.

Important

Do not leave the key to position (4) for a long time, or this could lead to battery discharge. Never leave the ignition key in the switch when you are leaving your motorcycle unattended.

Attention

The exhaust system might be hot, even after engine is switched OFF; pay particular attention not to touch the exhaust system with any body part and do not park the motorcycle next to inflammable material (wood, leaves etc.).

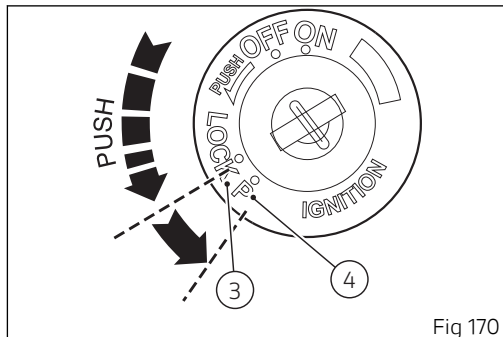

Attention

Using padlocks or other locks designed to prevent motorcycle motion, such as brake disc locks, rear sprocket locks, and so on is dangerous and may impair motorcycle operation and affect the safety of rider and passenger.

Tool kit and accessories

The tool box (1) is located under the seat.

The tool box includes:

- fuse pliers;
- two helmet anti-theft system cables;
- flat-blade/Phillips screwdriver;
- screwdriver handgrip;
- box wrench 14x16x145 mm (0.55x0.63x5.71 in);
- rod 6x120 mm (0.24x4.72 in);
- Allen wrench 3 mm (0.12 in);
- Allen wrench 4 mm (0.16 in);

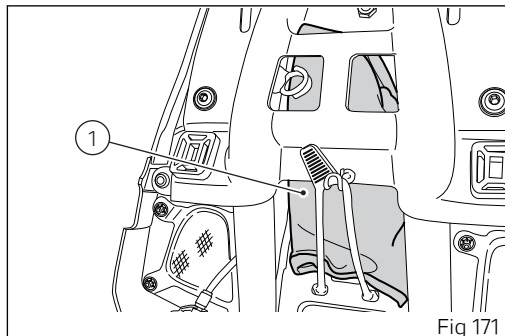

Fig 171

Main use and maintenance operations

Checking coolant level and topping up, if necessary

Check coolant level in the expansion reservoir on the right side of the steering tube.

Steer completely to the left and check that the level is between the MIN and MAX marks on the side of the expansion reservoir.

Top up if the level is below the MIN mark.

Unscrew the filler plug (1) and add ENI Agip Permanent Spezial antifreeze (do not dilute, use pure), until reaching the MAX level.

Screw plug (1) into seat.

This type of mixture ensures the best operating conditions (the coolant starts to freeze at $-20\text{ }^{\circ}\text{C}/-4\text{ }^{\circ}\text{F}$). Cooling circuit capacity: 2.5 cu. dm (litres) (0.66 gallons).

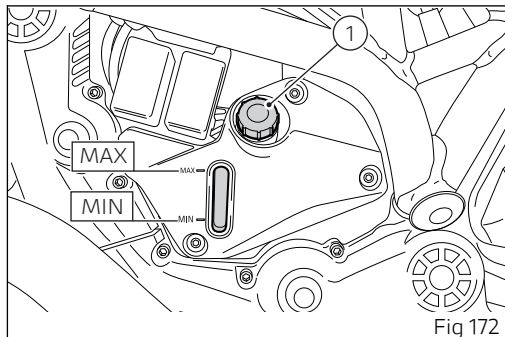

Fig 172



Attention

This operation must be performed with cold engine. Failure to observe the above recommendation may lead to coolant or hot vapour leakage with possible consequent severe burns.

Changing the air filter



Important

Have the air filter maintenance performed at a Ducati Dealer or Authorised Service Centre.

Check brake fluid level

The levels should not fall below the MIN marks on the respective reservoirs.

If level drops below the limit, air might get into the circuit and affect the operation of the system involved.

Brake and clutch fluid must be topped up and changed at the intervals specified in the scheduled maintenance table reported in the Warranty Booklet; please contact a Ducati Dealer or authorised Service Centre.

BRAKE SYSTEM

If you find exceeding clearance on brake lever or pedal and brake pads are still in good condition, contact your Ducati Dealer or authorised Service Centre to have the system inspected and any air drained out of the circuit.

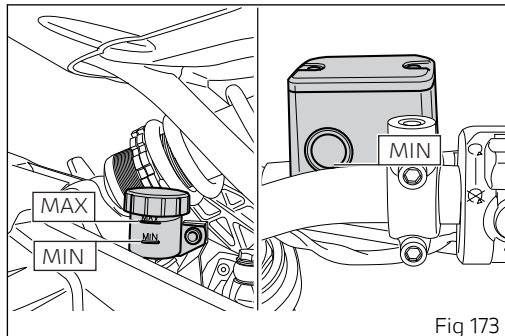

Fig 173



Attention

Brake fluid can damage paintwork and plastic parts, so avoid contact. Hydraulic fluid is corrosive; it may cause damage and lead to severe injuries. Never mix fluids of different qualities. Check seals for proper sealing.

Checking brake pads for wear

Check brake pads wear through the inspection hole in the callipers.

Change both pads if friction material thickness of even just one pad is about 1 mm (0,039 in).



Attention

Friction material wear beyond this limit would lead to metal support contact with the brake disc thus compromising braking efficiency, disc integrity and rider safety.



Important

Have the brake pads replaced at a Ducati Dealer or authorised Service Centre.

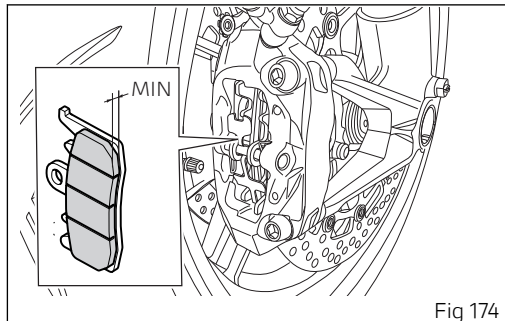

Fig 174

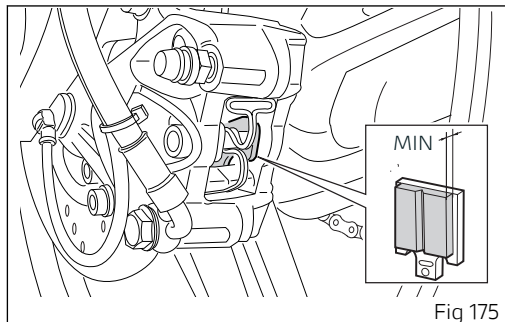

Fig 175

Charging the battery



Attention

Have the battery removed at a Ducati Dealer or authorised Service Centre.

To reach the battery, refer to "Removing the battery" page 242.



Attention

The battery gives off explosive gases; never cause sparks or allow naked flames and cigarettes near the battery. When charging the battery, ensure that the working area is properly ventilated.

Charge the battery in a ventilated room. Connect the battery charger leads to the battery terminals: the red one to the positive terminal (+), the black one to the negative terminal (-). Smear positive pole (+) and negative pole (-) screws with grease.

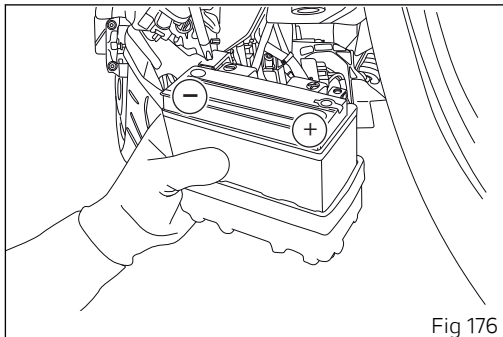

Fig 176



Important

Make sure the charger is OFF when you connect the battery to it, or you might get sparks at the battery terminals that could ignite the gases inside the cells. Always connect the red positive (+) terminal first.

Charge the battery at 0.9 A for 5÷10 hours.
Install the battery on the vehicle as described under
"Refitting the battery" page 249.



Attention

Keep the battery out of the reach of children.

Jump-starting the motorcycle

If the motorcycle must be jump-started in an emergency with an external starting device, first loosen screws (2) using the supplied wrench to remove the battery cover (1).

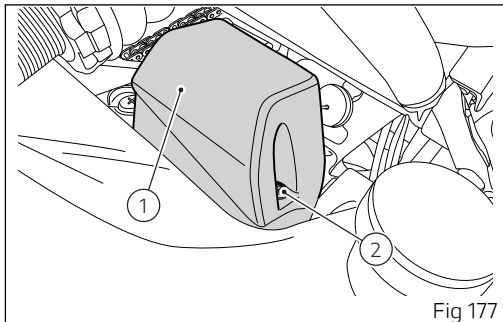

Fig 177

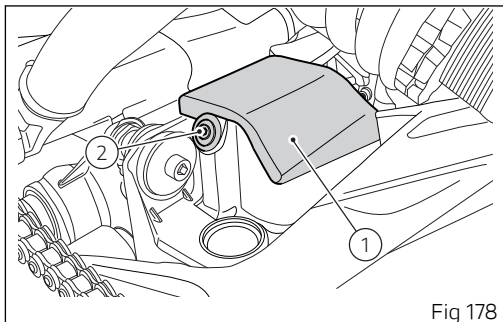

Fig 178

Connect the positive pole of the external device to the battery positive pole (3).
Connect the negative pole of the external device to engine mounting screw (4), after removing both covers on engine LH side.
To remove the covers, refer to "Removing the battery" page 242.

⚠ Attention

When connecting the positive pole of the external device to the positive pole (3) of the battery, pay utmost attention not to touch any other metal parts on the vehicle.

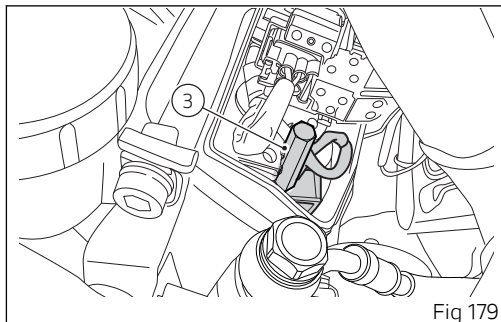

Fig 179

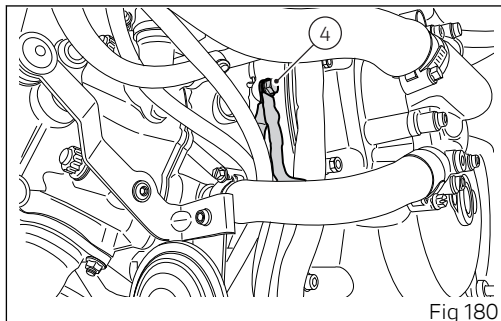

Fig 180

Charging and maintenance of the battery during winter storage

Your motorcycle is equipped with a connector (1), under the seat, to which you can connect a special battery charger (2) (Battery maintainer kit part no. 69924601A - various countries; Battery maintainer kit part no. 69924601AX - for Japan, China and Australia only) available from our sales network.

Note

The electric system of this model is designed so as to ensure there is a very low power drain when the motorcycle is OFF. Nevertheless, the battery features a certain self-discharge rate that is normal and depends on ambient conditions as well as on "non-use" time.

Important

If battery is not kept at a minimum charge level by a suitable battery charge maintainer, sulphation may occur and this is an irreversible phenomenon causing decreasing battery performance.

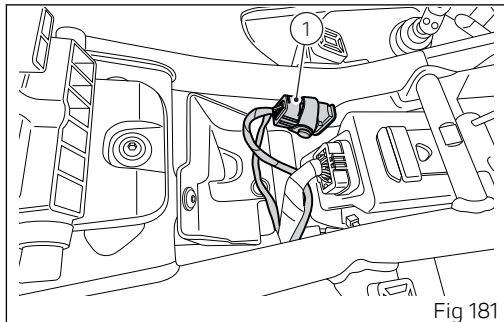

Fig 181

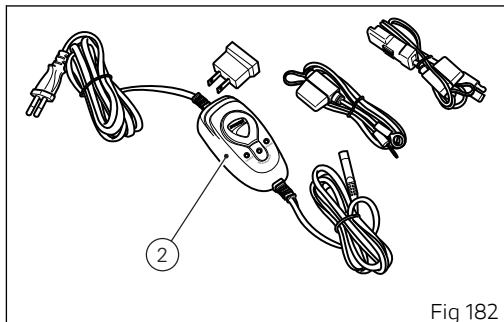

Fig 182

 **Note**

When the motorcycle is left unused (approximately for more than 30 days). We recommend owners to use the Ducati battery charge maintainer (Battery maintainer kit part no. 69924601A - various countries; Battery maintainer kit part no. 69924601AX - for Japan, China and Australia only) since its electronics monitors the battery voltage and features a maximum charge current of 1.5 Ah. Connect the maintainer to the diagnostics socket located in the rear side of the motorcycle.

 **Note**

Using charge maintainers not approved by Ducati could damage the electric system; motorcycle warranty does not cover the battery if damaged due to failure to comply with the above indications, since it is considered as wrong maintenance.

Removing the battery



Important

When battery must be removed, ALWAYS contact a Ducati Dealer or authorised Service Centre.

Loosen the screw (1) and remove the cover (2).
Loosen screws (3) and (4), and remove cover (5), pay attention to the canister (6) since it is fitted on the same cover.

Remove canister (6) from cover (5) disengaging rubber band (7) from its retainer: leave canister connected to vehicle.

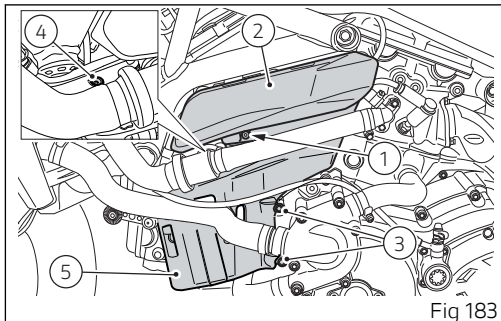

Fig 183

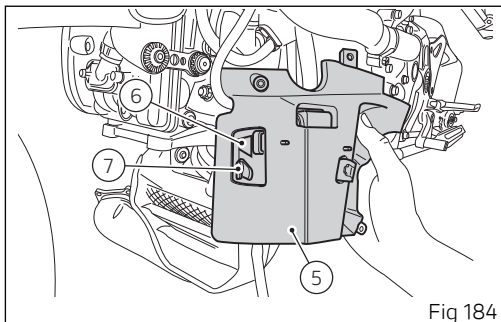

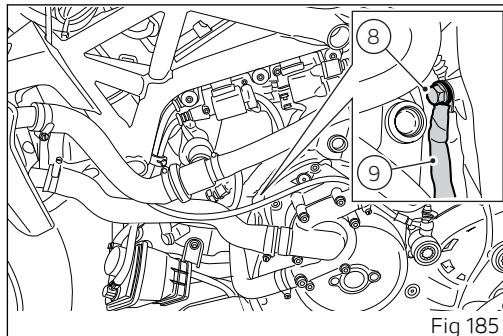

Fig 184

Undo the screw (8) and disconnect the ground cable (9).

 **Attention** Insulate the ground cable end you just removed to prevent it from touching the motorcycle.



Loosen screws (10) on battery cover (11).
Remove battery cover (11).

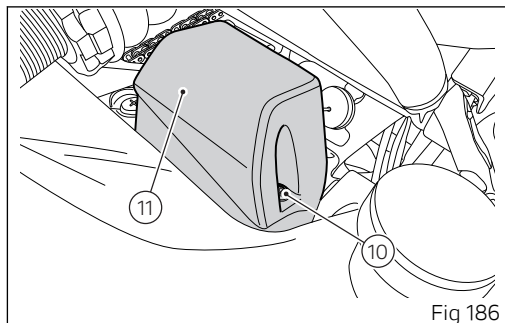

Fig 186

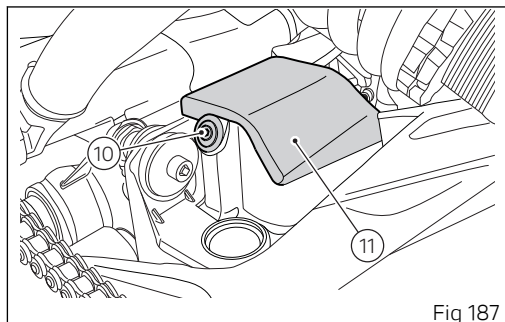
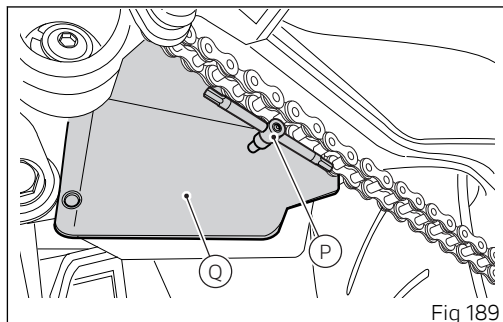
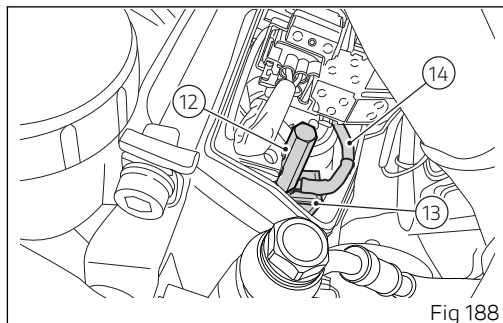
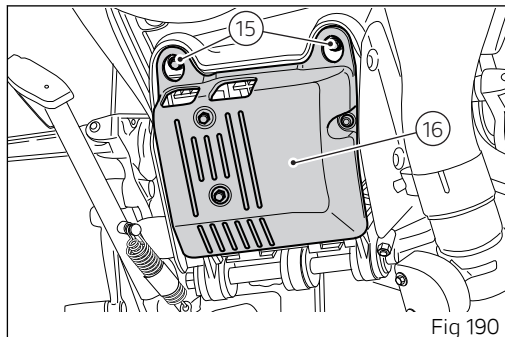

Fig 187

Loosen the special screw (12) retaining battery positive cable terminals (13) and ABS positive terminal (14) to battery positive pole.
Fit a service pin (P) in the hole on electric components support (Q) to change the battery.



Loosen the screws (15) securing battery mount cover (16) to electric components support.



Turn battery mount cover (16) down and remove service pin (P) while supporting the battery (17) with your hand.

Slowly slide down battery (17), pay attention to the negative pole which is still connected to the wiring.

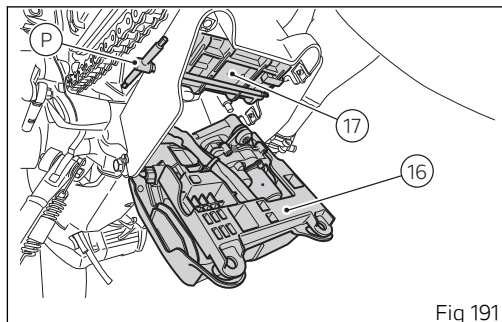

Fig 191

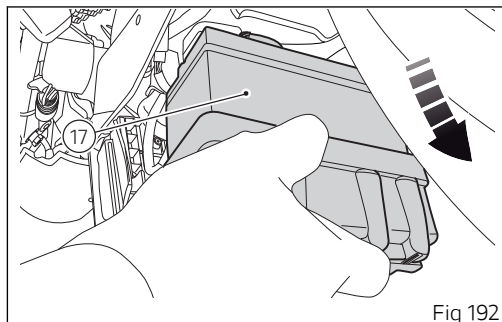

Fig 192

Loosen screw (18) securing negative cable (19) to battery negative pole and remove the battery.

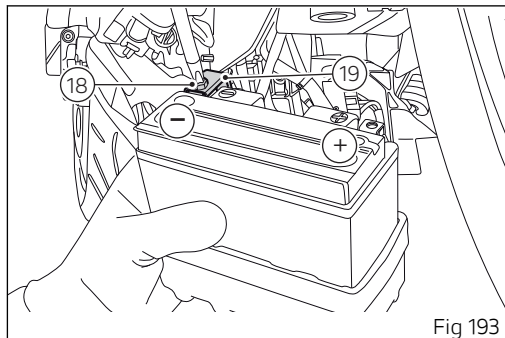

Fig 193

Refitting the battery



Important

When battery must be refitted, ALWAYS contact a Ducati Dealer or authorised Service Centre.

Fit the battery negative cable (19) on battery negative pole and fasten it by tightening screw (18) to $2.5 \text{ Nm} \pm 10\%$.

Install battery (17) in its seat, from swinging arm bottom side.

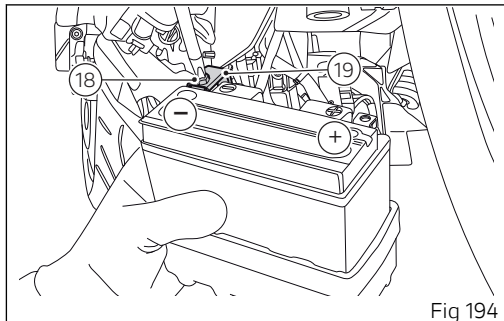

Fig 194

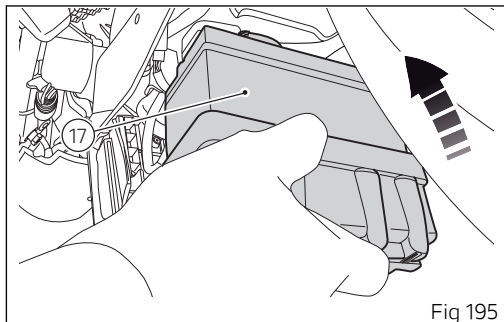

Fig 195

Once battery (17) is in place, fit service pin (P) in the hole on electric components support (Q) to support the battery.
Raise the battery mount cover (16) until it gets against the battery.

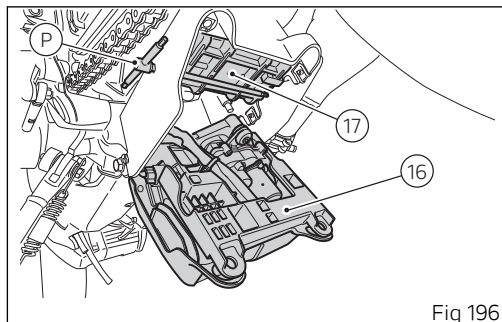

Fig 196

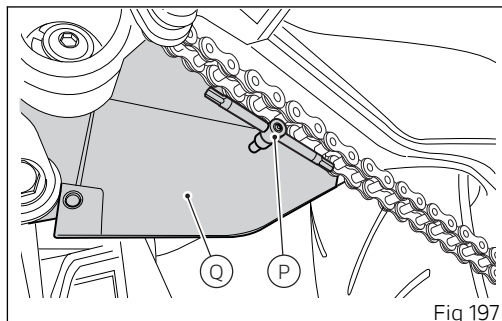
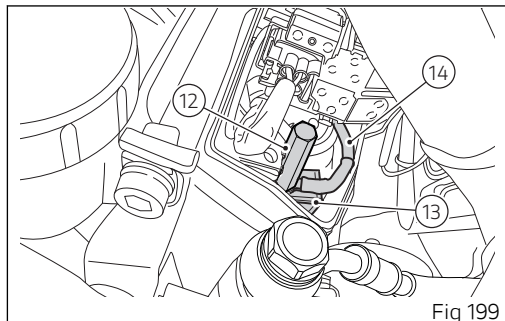
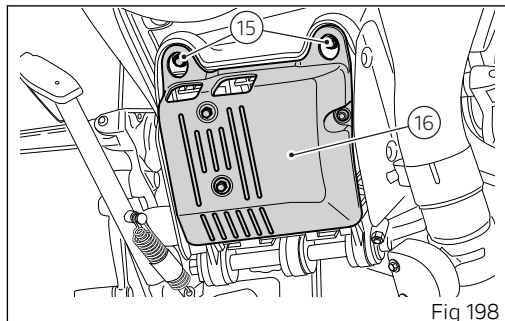
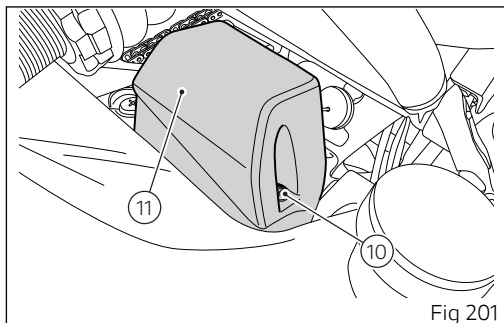
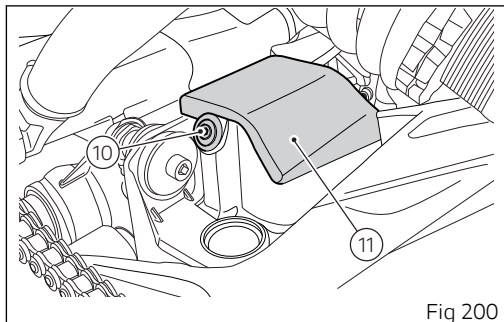

Fig 197

Slide out pin (P) and fasten battery mount cover (16) using screws (15); tighten them to $5 \text{ Nm} \pm 10\%$. Fit the positive cable (13) and ABS positive cable (14) on battery positive pole and fasten it by tightening screw (12) to $2.5 \text{ Nm} \pm 10\%$.



Fit the battery cover (11) on electric components support.
Start screws (10) and tighten them to a torque of 4 Nm \pm 10%.



Fit the ground cable (9) on motorcycle and fasten it by tightening screw (8) to $10 \text{ Nm} \pm 10\%$. Refit the canister (6) to cover (5) and fasten using rubber band (7).

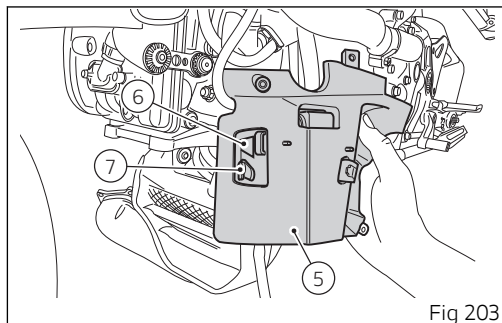
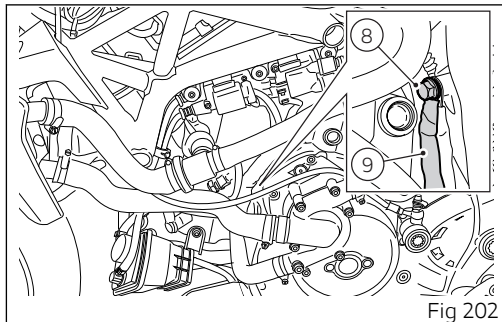

Fasten the cover (5) by tightening the screws (3) to a torque of $5 \text{ Nm} \pm 10\%$ and the screw (4) to a torque of $4 \text{ Nm} \pm 10\%$.

Install cover (2) and tighten the screw (1) to a torque of $3 \text{ Nm} \pm 10\%$.

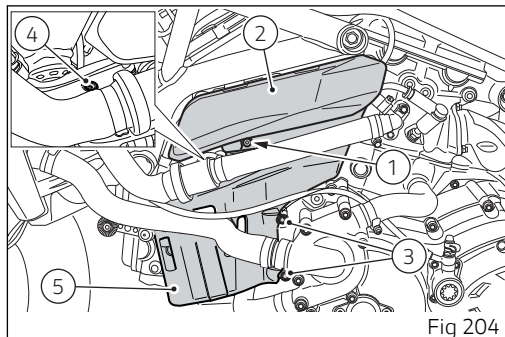

Checking drive chain tension



Important

Have chain tension adjusted by a Ducati Dealer or authorised Service Centre.

Make the rear wheel turn until you find the position where chain is tightest. Set the motorcycle on the side stand. With just a finger, push down the chain at the point of measurement and release. Measure the distance (A) between the centre of the chain pins and the aluminium section of the swinging arm. It must be: $A = 28 \div 30$ mm (1.10÷1.18 in).



Important

If drive chain is too tight or slack, adjust tension so as to bring values back to the specified range.

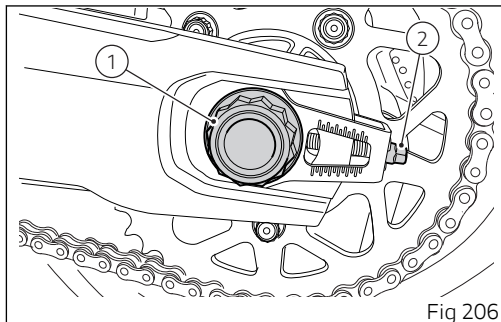
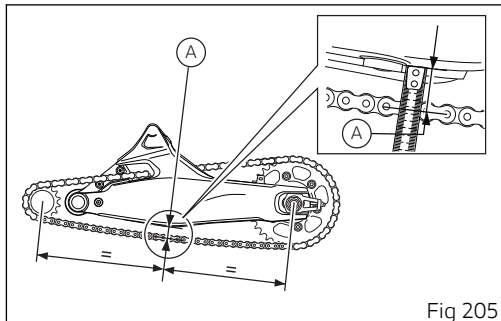



Attention

Correct tightening of the swingarm screws (2) is essential to rider and passenger safety.



Important

Improper chain tension will lead to early wear of transmission parts.

Check the correspondence of the positioning marks on both sides of the swinging arm to ensure a perfect wheel alignment. Grease the wheel shaft nut thread (1) with SHELL Retinax HDX2 and tighten it, together with nut (3) on the RH side, to a torque of 180 Nm (132.76 lbf ft).

Grease the adjuster screws (2) thread with SHELL Alvania R3 and tighten them to a torque of 10 Nm (7.37 lbf ft).



Important

To ensure the best performance and long life of the chain, please follow the information related to chain cleaning, lubrication, inspection and tensioning.

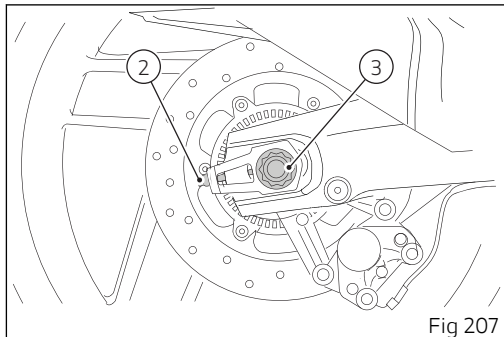

Fig 207

Lubricating the drive chain



Important

Have drive chain cleaned by a Ducati Dealer or authorised Service Centre.

Cleaning and lubricating the drive chain

The chain fitted on your motorcycle has O-rings that keep dirt out of and lubricant inside the sliding parts. Before proceeding with the chain lubrication it is important to correctly wash and clean it.

The chain cleaning is extremely important for its duration. In fact, it is necessary to remove any mud, soil, sand or dirt from the chain using a jet of water and then dry it immediately using compressed air at a distance of at least 30 cm (11.81 in).



Attention

Avoid the use of steam, fuel, solvents, hard brushes or other methods that could damage the O-rings; also avoid direct contact with the battery acid as it could cause mini cracks in the links as shown in the figure.



Attention

In particular, in case of Off-Road use of the bike, it is possible that excessive wear of the links occurs due to the contact with the chain sliding shoe; friction could in fact cause the chain to overheat, altering the heat treatment of the links and making them particularly fragile.

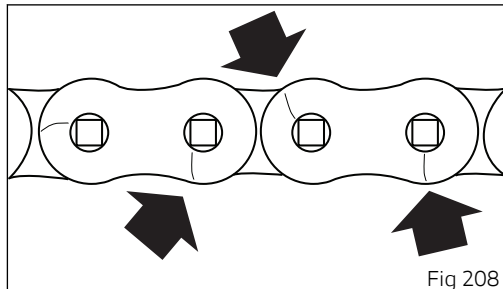

Lubricating the drive chain



Important

Have drive chain cleaned by a Ducati Dealer or authorised Service Centre.



Attention

Use SHELL Advance Chain to lubricate the chain; the use of non-specific lubricants could damage the O-rings and therefore the entire drive system.

It is recommendable to lubricate the chain without waiting for it to cool down after using the motorcycle, so that the new lubricant can penetrate better between the inner and outer links and be more effective in its protective action.

Place the bike on the rear paddock stand. Make the rear wheel turns fast in the opposite direction to the direction of travel.

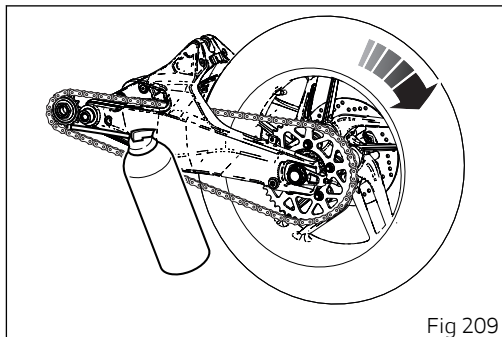

Apply the lubricant jet (1) inside the chain between the inner and outer links, in point (2) immediately before the engagement point on the sprocket.

Due to the centrifugal force, the lubricant, made fluid by the solvents contained in the spray, will expand in the working area between the pin and the bush, ensuring perfect lubrication.

Repeat the operation by aiming the lubricant jet to the central part (5) of the chain so as to lubricate the rollers (4), and to the outer plates (6) as shown in the figure.

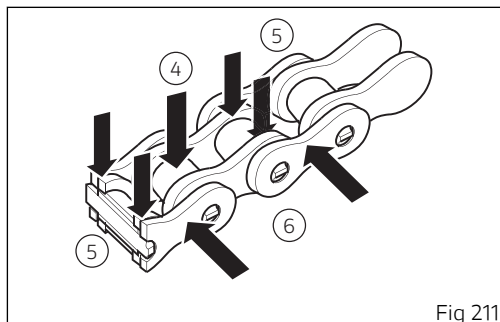
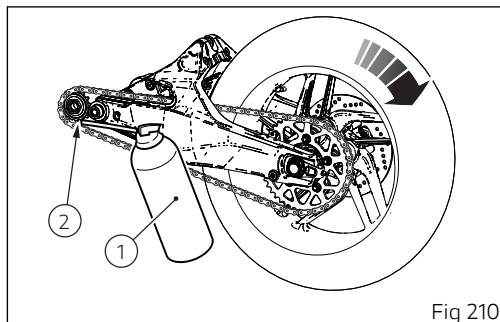

After lubrication, wait 10-15 minutes to allow the lubricant to act on the internal and external surfaces of the chain and then remove the excess lubricant with a clean cloth.

⚠ Important

Do not use the motorcycle immediately after lubricating the chain as the lubricant, still fluid, would be centrifuged outwards causing possible soiling of the rear tyre or the rider's footpeg.

⚠ Important

Check the chain often, taking care to lubricate it, as also indicated in the table below: at least every 1000 km (621 mi) or more frequently (about every 400 km (248 mi)) when using the bike with high outside temperatures (40°C) or after long travels on the highway at high speed.

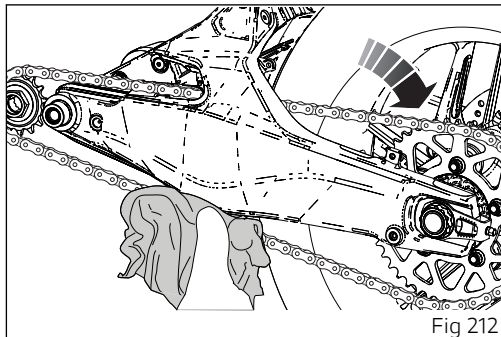

Changing bulbs

Before replacing a burnt-out bulb, make sure that the new one matches the voltage and wattage specifications in paragraph "Electric System" page 290.



Important

Have the bulbs changed at a Ducati Dealer or authorised Service Centre.

Undo the screw (1) and detach the lens (2) from the turn indicator support.

The bulb has a bayonet joint: press and twist counter clockwise to remove it. Remove the bulb, then fit the new one by pressing and turning clockwise until it clicks into its seat. Refit the lens by inserting the tab in the corresponding slot in the turn indicator support. Tighten the screw (1).

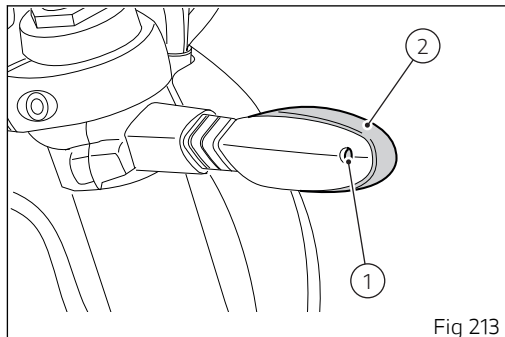

Fig 213

Aligning the headlight

Check correct headlight aiming. Position the motorcycle 10 metres (32.81 ft) from a wall or a screen, the motorcycle must be perfectly upright with the tyres inflated to the correct pressure and with a rider seated, perfectly perpendicular to the longitudinal axis. On the wall or surface, draw a horizontal line at the same height from the ground as the centre of the headlight and a vertical line aligned with the longitudinal axis of the motorcycle. If possible, perform this check in dim light. Switch on the low beam. The height of the upper limit between the dark area and the lit area must not be more than $\frac{9}{10}$ of the height from the ground of the headlight centre.

Note

This is the procedure specified by Italian regulations for checking the maximum height of the light beam. Please adapt said procedure to the provisions in force in your own country.

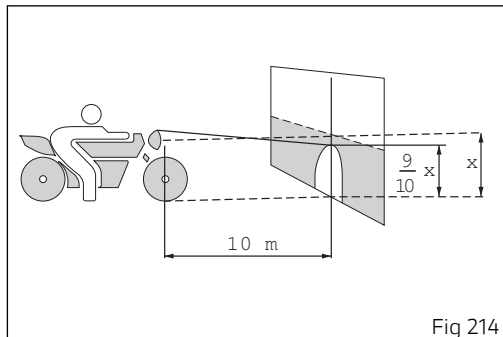

Fig 214

To vertically align the headlight beam, turn the screw (1).



Attention

The headlight might fog up if the motorcycle is used under the rain or after washing. Switch headlight on for a short time to dry up any condensate.

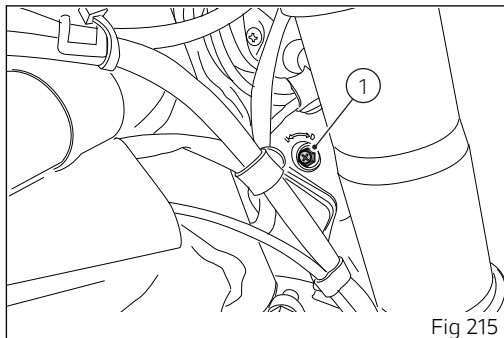

Fig 215

Tyres

Front tyre pressure:

2.3 bar (33.35 psi) (rider only) - 2.5 bar (36.26 psi) (rider and passenger).

Rear tyre pressure:

2.5 bar (36.26 psi) (rider only) - 2.8 bar (40.61 psi) (rider and passenger).

As tyre pressure is affected by ambient temperature and altitude variations, you are advised to check and adjust it whenever you are riding in areas where ample variations in temperature or altitude occur.

Important

Check and set tyre pressure when tyres are cold. To avoid front wheel rim distortion, when riding on bumpy roads, increase tyre pressure by 0.2 ÷ 0.3 bar (2.9 ÷ 4.35 psi).

TYRE REPAIR OR CHANGE

In the event of a tiny puncture, tubeless tyres will take a long time to deflate, as they tend to keep air inside. If you find low pressure on one tyre, check the tyre for punctures.

Attention

Punctured tyres must be replaced. Replace tyres with recommended standard tyres only. Be sure to tighten the valve caps securely to avoid leaks when riding. Never use tube type tyres. Failure to heed this warning may lead to sudden tyre bursting and to serious danger to rider and passenger.

After replacing a tyre, the wheel must be balanced.

Attention

Do not remove or shift the wheel balancing weights.

Note

Have the tyres replaced at a Ducati Dealer or authorised Service Centre. Correct removal and installation of the wheels is essential. Some parts of the ABS (such as sensors and phonic wheels) are mounted to the wheels and require specific adjustment.

Attention

Replace tyres with recommended standard tyres only, indicated in the Technical data in the paragraph "Tyres".

MINIMUM TREAD DEPTH

Measure tread depth (S) at the point where tread is most worn down: it should not be less than 2 mm (0,079 in), and in any case not less than the legal limit.



Important

Visually inspect the tyres at regular intervals for detecting cracks and cuts, especially on the side walls, bulges or large spots that are indicative of internal damage. Replace them if badly damaged. Remove any stones or other foreign bodies caught in the tread.

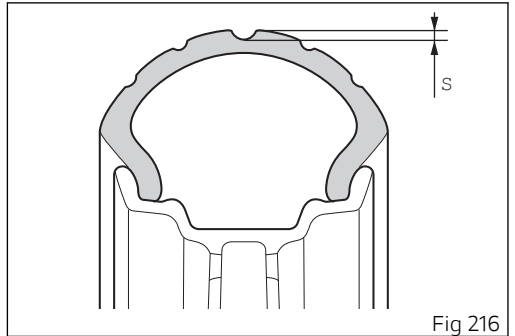

Check engine oil level

Engine oil level can be checked through the sight glass (1) located onto clutch cover.

Oil level should be between the marks on the sight glass. If the level is low, top up with engine oil.

Ducati recommends you use Shell Advance 4T Ultra 15W-50 oil (JASO: MA2 and API: SN).

Remove the oil filler cap (2) and top up until the oil reaches the required level. Refit the filler plug (2).

Important

Engine oil and oil filters must be changed by a Ducati Dealer or authorised Service Centre at the intervals specified in the scheduled maintenance chart reported in the Warranty Card.

To check the oil level correctly, carefully follow the instructions below.

1) The level must be checked with warm engine, so if it is not performed after riding for at least 20/30 minutes you will need to warm up the engine.

If, on the other hand, the engine is cold, start it and let it warm up until the cooler fans start two consecutive times (the engine oil must be perfectly

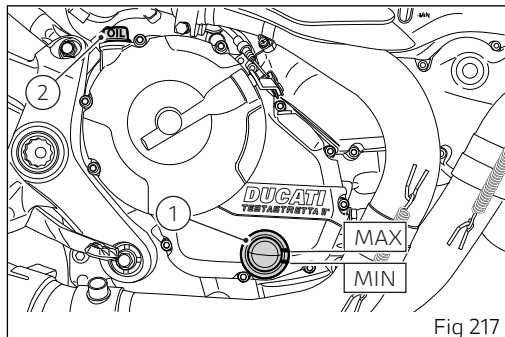

warm to flow along the lines and reach the engine sump).

During this warming up phase, the bike can be left on the side stand.

- 2) Turn off the engine and wait 10\15 minutes to allow the oil to flow completely inside the sump.
- 3) Position the bike with both wheels on a flat ground and in straight position.
- 4) Then, check the engine oil through the sight glass.
- 5) If the oil level is below the middle line between the MIN and MAX marks, add oil until reaching the maximum level indication.



Attention

Never exceed the MAX mark.

Recommendations concerning oil

It is recommended to use oil complying with the following specifications:

- viscosity grade SAE 15W-50;
- standard API: SN;
- standard JASO: MA2.

SAE 15W-50 is an alphanumeric code identifying oil class based on viscosity: two figures with a W ("winter") in-between; the first figure indicates oil viscosity at low temperature; the second figure indicates its viscosity at high temperature. API (American standard) and JASO (Japanese standard) standards specify oil characteristics.

Cleaning and replacing the spark plugs

Spark plugs are essential to smooth engine running and should be checked at regular intervals. Have the spark plug replaced by a Ducati Dealer or an authorised Service Centre.

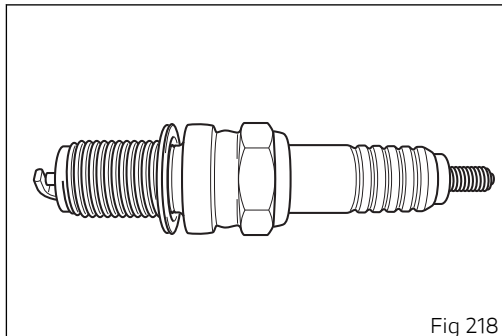

Fig 218

Cleaning the motorcycle

To preserve the finish of metal parts and paintwork, wash and clean your motorcycle at regular intervals, anyway according to road conditions. Use specific products only. Prefer biodegradable products. Avoid aggressive detergents or solvents.

Use only water and neutral soap to clean the Plexiglas and the seat. Periodically clean by hand all aluminium components. Use special detergents, suitable for aluminium parts. Do NOT use abrasive detergents or caustic soda.



Note

Do not use sponges with abrasive parts or steel wool: only use soft cloths.

However, the warranty does not apply to motorcycles whenever poor maintenance status is ascertained.



Important

Do not wash your motorcycle right after use. When the motorcycle is still hot, water drops will evaporate faster and spot hot surfaces.

Never clean the motorcycle using hot or high-pressure water jets.

Cleaning the motorcycle with a high pressure water jet may lead to seizure or serious faults in forks, wheel hubs, electric system, headlight (fogging), fork seals, air inlets or exhaust silencers, with consequent loss of compliance with the safety requirements.

Clean off stubborn dirt or exceeding grease from engine parts using a degreasing agent. Be sure to avoid contact with drive parts (chain, sprockets, etc.).

Rinse with warm water and dry all surfaces with chamois leather.



Attention

Braking performance may be impaired immediately after washing the motorcycle. Never grease or lubricate the brake discs to avoid losing braking power. Clean the discs with an oil-free solvent.



Attention

The headlight might fog up due to washing, rain or moisture. Switch headlight on for a short time to help and dry up any condensate.

Carefully clean the phonic wheels of the ABS in order to ensure system efficiency. Do not use aggressive products in order to avoid damaging the phonic wheels and the sensors.



Important

To clean and lubricate the drive chain, refer to the paragraph "Lubricating the drive chain".

Storing the motorcycle

If the motorcycle is to be left unriden over long periods, it is advisable to carry out the following operations before storing it away:

- clean the motorcycle;
- empty the fuel tank;
- pour a few drops of engine oil into the cylinders through the spark plug seats, then crank the engine by hand a few times so a protective film of oil will spread on cylinder inner walls;
- place the motorcycle on the service stand;
- disconnect and remove the battery.

Battery should be checked and charged whenever the motorcycle has been left unriden for over a month.

Protect the motorcycle with a suitable canvas. This will protect paintwork and let condensate breathe out. The canvas is available from Ducati Performance.

Important notes

Some countries, such as France, Germany, Great Britain, Switzerland, etc. have compulsory emission and noise standards that include mandatory inspections at regular intervals.

Periodically carry out the required checks and renew parts as necessary, using Ducati original spare parts, in compliance with the regulations in the country concerned.

Scheduled maintenance chart

Scheduled maintenance chart: operations to be carried out by the dealer

List of operations and type of intervention [set mileage (km/mi) or time interval *]	Km. x1000	1	15	30	45	60	Time (months)
	mi. x1,000	0.6	9	18	27	36	
Reading of the error memory with DDS and check of software version update on control units		•	•	•	•	•	12
Check the presence of any technical updates and recall campaigns		•	•	•	•	•	12
Change engine oil and filter		•	•	•	•	•	12
Clean the engine oil mesh filter assembly		•		•		•	-
Check and/or adjust valve clearance				•		•	-
Change timing belts				•		•	60
Change spark plugs			•	•	•	•	-
Clean air filter			•		•		-
Change air filter				•		•	-
Check brake fluid level		•	•	•	•	•	12
Change brake fluid							36

List of operations and type of intervention [set mileage (km/mi) or time interval *]	Km. x1000	1	15	30	45	60	Time (months)
	mi. x1,000	0.6	9	18	27	36	
Check brake disc and pad wear. Change, if necessary		•	•	•	•	•	12
Check the proper tightening of the front and rear brake calliper bolts and the front brake disc flange screws		•	•	•	•	•	12
Check the proper tightening of the rear brake disc and phonic wheel bolts (with removal of rear wheel shaft, if necessary)			•	•	•	•	12
Check front and rear wheel nuts tightening		•	•	•	•	•	12
Check frame-to-engine fasteners tightening			•	•	•	•	-
Check wheel hub bearings				•		•	-
Check the proper tightening of final drive front and rear sprocket nuts		•	•	•	•	•	12
Check final drive (chain, front and rear sprocket) and sliding shoe wear			•	•	•	•	12
Check final drive chain tension and lubrication		•	•	•	•	•	12
Check steering bearings and lubricate, if necessary				•		•	-
Change front fork fluid					•		-

List of operations and type of intervention [set mileage (km/mi) or time interval *]	Km. x1000	1	15	30	45	60	Time (months)
	mi. x1,000	0.6	9	18	27	36	
Visually check the front fork and rear shock absorber seals		•	•	•	•	•	12
Check the freedom of movement and tightening of the side and central stand (if any)		•	•	•	•	•	12
Visually check the fuel lines			•	•	•	•	12
Check rubbing points, clearance, freedom of movement and positioning of hoses and electric wiring in view		•	•	•	•	•	12
Check the free play of clutch lever		•	•	•	•	•	12
Lubricate the levers at the handlebar and pedal controls			•	•	•	•	12
Change coolant					•		48
Check the coolant level and check circuit for damage		•	•	•	•	•	12
Check tyre pressure and wear		•	•	•	•	•	12
Check the battery charge level		•	•	•	•	•	12
Check the operation of all electric safety devices (side stand sensor, front and rear brake switches, engine kill switch, gear/neutral sensor)		•	•	•	•	•	12
Check lighting, turn indicators, horn and controls		•	•	•	•	•	12

List of operations and type of intervention [set mileage (km/mi) or time interval *]	Km. x1000	1	15	30	45	60	Time (months)
	mi. x1,000	0.6	9	18	27	36	
Reset the Service indication through the DDS 2.0		●	●	●	●	●	12
Final test and road test of the motorcycle, testing safety devices (ex. ABS and DTC), electric fans and idling		●	●	●	●	●	12
Softly clean the motorcycle		●	●	●	●	●	12
Fill out that the service was performed in on-board documentation (Service Booklet)		●	●	●	●	●	12

Scheduled maintenance chart: operations to be carried out by the customer



Important

Using the motorcycle under extreme conditions, such as very damp and muddy roads or dusty and dry environment, could cause above-average wear of components like the drive system, the brakes or the air filter. If the air filter is dirty, the engine could get damaged. Therefore, this might translate in required service or replacement of the wear parts earlier than specified in the scheduled maintenance chart.

List of operations and type of intervention [set mileage (km/mi) or time interval *]	Km. x1000	1
	mi. x1,000	0.6
	Months	6
Check engine oil level		●
Check brake fluid level		●
Check tyre pressure and wear		●
Check the drive chain tension and lubrication		●
Check brake pads. If necessary, contact your dealer to replace pads		●

* Service operation to be carried out in accordance with the specified distance or time intervals (km or months), whichever occurs first

Technical data

Weights

Overall weight (in running order with 90% of fuel - 44/2014/EU Annex XI): 206 kg (454.15 lb).

Dry weight (without fluids and battery): 195 kg (429.9 lb).

Maximum allowed weight (carrying full load): 390 kg (859.8 lb).



Attention

Failure to observe weight limits could result in poor handling and impair the performance of your motorcycle, and you may lose control of the motorcycle.

Dimensions

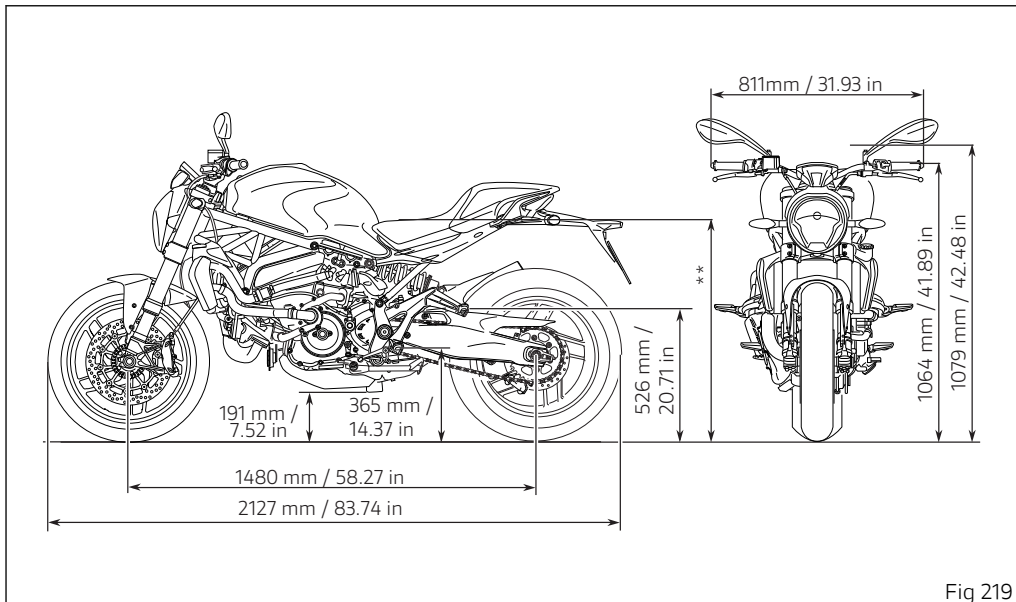

Fig 219

** Adjustable seat height 785 mm - 810 mm (30.90 in - 31.89 in).

Fuel, lubricants and other fluids

TOP-UPS	TYPE	
Fuel tank, including a reserve of 2.5 litres (0.55 UK gal)	Ducati recommends SHELL V-Power unleaded premium fuel with a minimum of octane rating of RON 95	16.5 litres (3.63 UK gal)
Oil sump and filter	Ducati recommends you use SHELL Advance 4T Ultra 15W-50 oil (JASO: MA2, API: SN)	3.2 litres (0.70 UK gal)
Front/rear brake circuit	DOT 4	-
Protectant for electric contacts	Protective spray for electric systems	-
Front fork	SHELL Donax TA	521 cu. cm (RH leg) (31.8 cu in) 394 cu. cm (LH leg) (24.04 cu in)
Rear shock absorber	-	112 cu. cm (6.83 cu in).
Cooling circuit	ENI Agip Permanent Spezial antifreeze (do not dilute, use pure)	2.5 (litres) (0.55 UK gal)



Important

Do not use any additives in fuel or lubricants. Using them could result in severe damage of the engine and motorcycle components.



Attention

The motorcycle is only compatible with fuel having a maximum content of ethanol of 10% (E10). Using fuel with ethanol content over 10% is forbidden. Using it could result in severe damage of the engine and motorcycle components. Using fuel with ethanol content over 10% will make the warranty null and void.



Important

These references indicate the fuel recommended for this vehicle as specified by the European regulation EN228.



Engine

90° L-type twin-cylinder - 4-stroke Otto cycle engine - with high sump die-cast crankcase

Bore: 88 mm (3.46 in)

Stroke: 67.5 mm (2.66 in)

Total displacement: 821.1 cu. cm (50.10 cu in).

Compression ratio: 12.8±0.5

Maximum power at crankshaft (EU) Regulation no. 134/2014, Annex X, kW/HP:

80 kW/109 HP at 9250 rpm.

Maximum power at crankshaft (EU) Regulation no. 134/2014, Annex X, kW/HP:

(35 kW version) 34 kW/46 HP at 8000 rpm.

Maximum torque at crankshaft (EU) Regulation no. 134/2014 Annex X:

86 Nm/8.8 kgm at 7750 rpm

Maximum torque at crankshaft (EU) Regulation no. 134/2014 Annex X:

(35 kW version) 56 Nm/5.7 kgm at 4750 rpm

Max. rotation speed: 10500 rpm.



Important

Do not exceed the specified rpm limits in any running conditions.



Note

The indicated power/torque values have been measured with a static test bench according to type-approval standards and match with the data detected during type-approval process; they are indicated in the vehicle registration document.

Timing system

DESMODROMIC system with four valves per cylinder controlled by eight rocker arms (four opening and four closing ones) and two overhead camshafts. This system is driven by the crankshaft through spur gears, pulleys and toothed belts.

Desmodromic timing system

- 1) Opening (or upper) rocker arm;
- 2) Upper rocker arm shim;
- 3) Closing (or lower) rocker arm shim;
- 4) Return spring for lower rocker arm;
- 5) Closing (or lower) rocker arm;
- 6) Camshaft;
- 7) Valve.

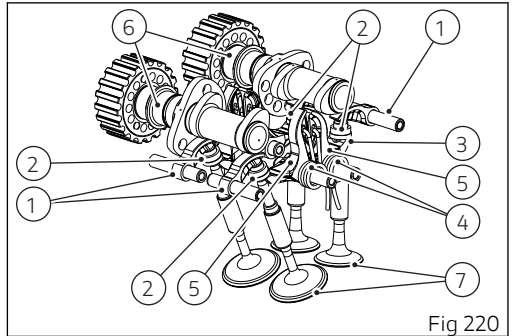

Performance data

Maximum speed in any gear should be reached only after a correct running-in period with the motorcycle properly serviced at the recommended intervals.



Important

Failure to follow these instructions releases Ducati Motor Holding S.p.A. from any liability whatsoever for any engine damage or shorter engine life.

Spark plugs

Make: NGK

Type: MAR9-J.

Fuel system

Synerject CONTINENTAL ECU M3D indirect electronic injection.

MIKUNI throttle body with full Ride by wire system, diameter: 53 mm (2.09 in), round cross-section

Injectors per cylinder: 1

Firing points per injector: 4

Fuel supply: 95-98 RON.



Attention

The motorcycle is only compatible with fuel having a maximum content of ethanol of 10% (E10). Using fuel with ethanol content over 10% is forbidden. Using it could result in severe damage of the engine and motorcycle components. Using fuel with ethanol content over 10% will make the warranty null and void.

Brakes

Separate-action anti-lock brake system operated by hall-type sensors mounted to each wheel with phonic wheel detection: ABS can be disabled.

Front

Type: with drilled steel disc.

no. 2 discs.

Disc diameter: 320 mm (12.60 in).

Hydraulically operated by a control lever on handlebar right-hand side.

Monoblock brake callipers with separate pistons.

Make and type: Brembo M4.32 b.

Friction material: Toshiba TT2182FF.

Master cylinder type:

PS 16/22.

Cylinder Ø: 16 mm (0.63 in).

Rear

Type: with fixed drilled steel disc.

Disc diameter: 245 mm (9.64 in).

Hydraulically operated by a pedal on RH side.

Brake calliper: 2 pistons Ø34 mm (1.34 in).

Make and type: Brembo M4.32b.

Friction material: Toshiba TT2172 HH.

Master cylinder type: PS 11/34.

Cylinder Ø: 11 mm (0.43 in).



Attention

The brake fluid used in the brake system is corrosive.

In the event of accidental contact with eyes or skin, wash the affected area with abundant running water.

Transmission

Wet clutch controlled by the lever on left-hand side of the handlebar.

Drive is transmitted from engine to gearbox primary shaft via spur gears.

Front chain sprocket/clutch gearwheel ratio: 33/61.

6-speed gearbox with constant mesh gears and gear change pedal on left side of motorcycle.

Gearbox output sprocket/rear chain sprocket ratio: 15/46.

Total gear ratios:

1st gear 15/37

2nd gear 17/30

3rd gear 20/28

4th gear 22/26

5th gear 24/23

6th gear 23/24

Drive chain from gearbox to rear wheel.

Make: Regina

Type: 520 ZRDK

Links: 108



Important

The above gear ratios are the homologated ones and under no circumstances must they be modified.



Attention

If the rear sprocket needs replacing, contact a Ducati Dealer or authorised Service Centre. If improperly replaced, this component could seriously endanger your safety, as well as the passenger one, and cause irreparable damage to your motorcycle.

Frame

Tubular ALS 420 steel trellis frame fastened to the cylinder heads.

Tubular ALS 420 steel trellis rear subframe fastened to the cylinder heads.

Steering angle (per side): 30°

Steering head angle: 24.3°

Trail in mm: 93.2 (3.67 in).

Wheels

10-spoke, light-alloy rims.

Front

Size: MT3.50x17"

Rear

Size: MT5.50x17"

Both wheel shafts can be removed.

Tyres

Front

"Tubeless", radial tyre.

Size: 120/70-ZR17

Rear

"Tubeless", radial tyre.

Size: 180/55-ZR17

Suspension

FRONT

KAYABA hydraulic upside-down fork.

Stanchion diameter: 43 mm (1.69 in).

Wheel travel: 130 mm (5.12 in).

REAR

Progressive with Sachs monoshock, with rebound and spring preload adjustment.

Suspension travel: 61.5 mm (2.42 in).

Rear wheel travel: 147 mm (5.79 in).

Exhaust system

Single silencer in stainless steel, aluminium tailpipe cover; catalytic converter and double lambda sensor.

Available colours

(this model is provided with seat cover)

DUCATI RED

Primer code L0040652 (Lechler).

Base coat 473.101 (PPG).

Clear coat code 96230 (Lechler).

Frame, Red code QG000K (Akzo Nobel).

Rims, Black.

DARK STEALTH

Primer code 873.A002 (Palinal).

Base coat code 929.R223 (Palinal).
Clear coat code 923I.2176 (Palinal).
Charcoal black frame code MY/2/9611AV (Akzo Nobel).
Rims, Black.

DUCATI YELLOW

Primer code 873I2396 (Palinal).
Base coat code 929T940 (Palinal).
Clear coat code 923M1598 (Palinal).
Charcoal black frame code MY/9611AV (Akzo Nobel).

Electric system

Basic electric items are:

HEADLIGHT:

low beam: H7 (12 V - 55 W);

high beam: H1 (12 V - 55 W);

parking light: fourteen LEDs (3.9 W).

ELECTRICAL CONTROLS ON HANDLEBAR

Front turn indicators: RY 10W (12 V - 10 W);

Rear turn indicators: RY 10W (12 V - 10 W).

Horn.

Stop light switches.

Battery, 12 V-10 Ah.

Generator 490 W - 14 V - 34.8 A.

Electronic rectifier, protected by a 30 A fuse.

Starter motor, 12 V-0.7 kW.

TAIL LIGHT:

parking light: eight LEDs, (13.5 V - 0.45 W);

rear stop light: twelve LEDs (13.5 V - 2.8 W);

Number plate light: three LEDs (13.5 V - 0.67 W).



Note

For the bulb replacement refer to paragraph "Replacing the bulbs".

Fuses

Electric components are protected by eleven fuses located in the fuse box. There are three spare fuses in every box. Above the solenoid starter there are two 30 A fuses, whereas on its sides there are two ABS fuses: a 25 A and a 30 A one.

The fuse boxes are located on the RH central side, under the RH side cover. Fuse box (A) is on the LH side, whereas fuse box (B) is on the RH side. To expose the fuses, lift the box protective covers. Mounting position and ampere capacity are marked on box cover. Refer to the table below to identify the circuits protected by the various fuses and their ratings.

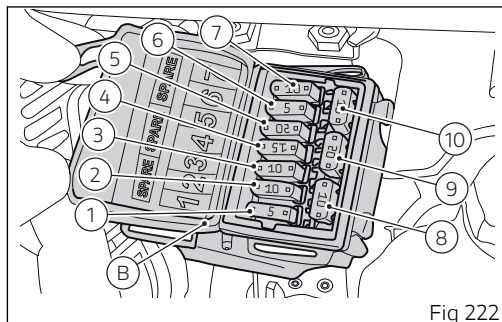
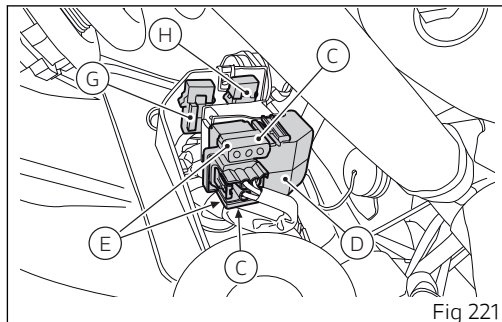

Fuse box (A) key		
Pos	El. item	Rat.
1	Optional key	7.5 A
2	Alarm	5 A
3	Stop	5 A
4	Diagnostics	3 A
5	Spare	7.5 A
6	Spare	25 A
7	Spare	30 A

Fuse box (B) key		
Pos	El. item	Rat.
1	Lights	5 A
2	Instrument panel	10 A
3	Key 1	10 A
4	Key 2	15 A
5	Relay	20 A
6	Control unit	5 A
7	BBS	10 A
8	Spare	10 A
9	Spare	20 A
10	Spare	15 A

The main fuses (C) (an active and a spare one) are located on solenoid starter (D). Remove the fuse protection cap (E) to reach the fuses. A blown fuse can be identified by breakage of the inner filament (F). Near the solenoid starter there are two fuses: a 25 A (G) fuse and a 30 A (H) one.

⚠ Important
Switch the ignition key to OFF before replacing the fuse to avoid possible short-circuits.

⚠ Attention
Never use a fuse with a rating other than specified. Failure to observe this rule may damage the electric system or even cause fire.

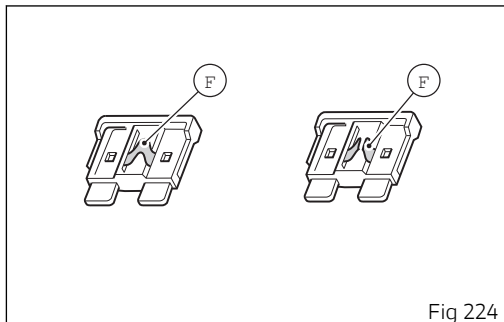
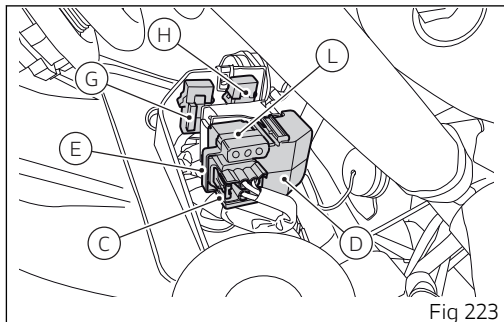

Injection/electric system diagram key

- | | |
|--------------------------------------|------------------------------------------------------|
| 1) Ignition system (ignition switch) | 25) Alarm (optional) |
| 2) - | 26) - |
| 3) Supplementary socket (optional) | 27) Heated handgrip power supply |
| 4) LH fan | 28) Fuel level sensor |
| 5) RH fan | 29) Side stand switch |
| 6) Generator | 30) Timing/rpm sensor |
| 7) Rectifier | 31) MAP sensor |
| 8) Starter motor | 32) Gear sensor |
| 9) Solenoid starter | 33) Engine temperature |
| 10) Battery | 34) Ambient air temperature (TIA) |
| 11) ABS fuses | 35) Horizontal exhaust lambda sensor |
| 12) Wiring ground | 36) Vertical exhaust lambda sensor |
| 13) Exhaust valve motor | 37) Purge Valve |
| 14) ABS control unit | 38) Throttle twistgrip position sensor (APS) |
| 15) Front fuse box | 39) Horizontal injector |
| 16) Rear fuse box | 40) Vertical injector |
| 17) Front speed sensor | 41) Potentiometer motor / ride-by-wire (TPS/
ETV) |
| 18) Rear speed sensor | 42) Secondary air actuator |
| 19) Self-diagnosis/DDA | 43) Vertical coil |
| 20) Rear right turn indicator | 44) Horizontal coil |
| 21) Tail light | 45) Fuel pump |
| 22) Rear left turn indicator | 46) Fuel pump relay |
| 23) Number plate light | 47) Injection power supply relay |
| 24) BBS | 48) Control unit (A) |
| | 49) Control unit (B) |

- 50) Left-hand switch
- 51) Front left turn indicator
- 52) Clutch switch
- 53) -
- 54) Air temperature sensor
- 55) Horn
- 56) Instrument panel
- 57) Starter relay
- 58) Rear stop light
- 59) Front stop light
- 60) Front right turn indicator
- 61) -
- 62) Headlight
- 63) Right-hand switch
- 64) Immobilizer

Wire colour coding

- B Blue
- W White
- V Violet
- Bk Black
- Y Yellow
- R Red
- Lb Light blue
- Gr Grey

- G Green
- Bn Brown
- O Orange
- P Pink



Note

The electric system wiring diagram is at the end of this manual.

Routine maintenance record

Routine maintenance record

KM	NAME	MILEAGE	DATE
	DUCATI SERVICE		
1000			
15000			
30000			
45000			
60000			

Stampato 06/2019

Cod. 913.7.433.1A

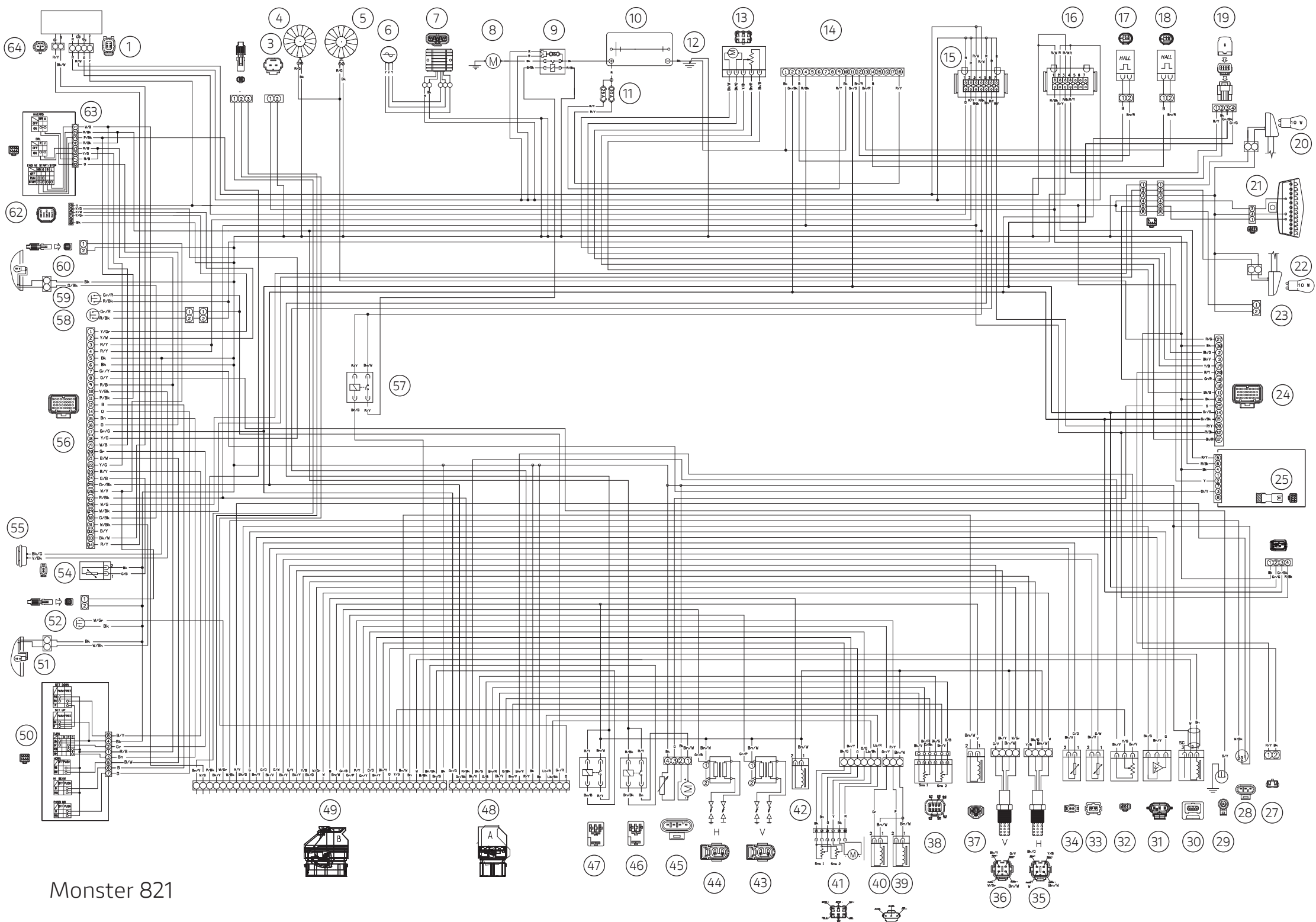

Monster 821

Ducati Motor Holding spa
ducati.com

Via Cavalieri Ducati, 3
40132 Bologna, Italy
Ph. +39 051 6413111
Fax +39 051 406580

A Sole Shareholder Company
A Company subject to the Management
and Coordination activities of AUDI AG