

Owner's manual

# **HYPERMOTARD 950**



Owner's manual

ENGLISH

# ***HYPERMOTARD*** ***950***

This manual forms an integral part of the motorcycle and must be kept with it for its whole service life. If the motorcycle is resold, the manual must always be handed over to the new owner. This manual must be preserved with care. If it is lost or becomes damaged, contact a Ducati Dealer or authorised Service Centre without delay to obtain a new copy of the manual.

The quality standards and safety of Ducati motorcycles are steadily improved as new design solutions, equipment and accessories are developed. While the information contained in this manual is current at the time of going to print, Ducati Motor Holding S.p.A. reserves the right to make changes at any time without notice and without any obligations. For this reason, the illustrations in this manual might differ from your motorcycle.

Any and all reproduction or spreading of the contents herein in whole or in part is forbidden. All rights reserved to Ducati Motor Holding S.p.A. Any request for written authorisation shall be addressed to this company, specifying the reasons for request.

Enjoy your ride!

# Table of contents

Introduction	8
Safety guidelines	8
Warning symbols used in the manual	9
Intended use	10
Rider's obligations	10
Rider's training	11
Apparel	12
Safety "Best Practices"	13
Refuelling	15
Carrying the maximum load allowed	16
Information about carrying capacity	16
Dangerous products - warnings	17
Vehicle identification number	19
Engine identification number	20
Instrument panel (Dashboard)	21

Instrument panel	21
Acronyms and abbreviations used in the Manual	24
Technological Dictionary	25
Information statement on UE directive 2014/53/UE	27
Function buttons	30
Parameter displaying	31
Main and auxiliary functions	37
Vehicle speed indication	39
Gear indication	40
Engine rpm indication	41
DQS indicator - accessory	42
DTC indicator	44
ABS indicator	50
DWC indicator	56
Clock	62
Engine Coolant temperature	63
Riding mode	64
Function menu	69
Odometer (TOT)	70
Trip meter 1 (TRIP 1)	71
Average Fuel Consumption 1 (CONS.AVG 1)	73
Average speed 1 (SPEED AVG 1)	75
Trip time 1 (TRIP TIME 1)	77

Ambient air temperature (T AIR)	79	Setting menu - riding mode- restore values (Default)	112
Partial fuel reserve counter (TRIP FUEL)	80	Setting menu - riding mode - restore all values for all riding modes (All Default)	113
Trip meter 2 (TRIP 2)	81	Setting menu - pin code activation (Pin Code)	114
Instantaneous fuel consumption (CONS.)	83	Setting menu - pin code modification (Pin Code)	119
Music player management (PLAYER) - accessory	84	Setting menu - lap time (Lap)	125
Call management (LAST CALLS) - accessory	91	Setting menu - setting the backlighting (Backlight)	131
Heated handgrips (HEATING GRIPS) - accessory	93	Setting menu - setting the date and time (Date and Clock)	133
Setting menu (SETTING MENU)	95	Setting menu - unit of measurement setting (Units)	139
Setting menu - riding mode (Riding Mode)	97	Setting menu - service information (Service)	146
Setting menu - riding mode- setting the engine (Engine)	100	Setting menu - tyre setting and drive ratio (Tyre Calibration)	147
Setting menu - riding mode- setting the DTC (DTC)	102	Setting menu - DRL light mode setting - accessory (DRL Control)	152
Setting menu - riding mode- setting the ABS (ABS)	105	Setting menu - setting Bluetooth devices - accessory (Bluetooth)	154
Setting menu - riding mode- setting the DWC (DWC)	107	Setting menu - turn indicator mode setting (Turn Indicators)	162
Setting menu - riding mode - setting the DQS - accessory (DQS)	110	Setting menu - information (Info)	164

Lap time (Lap) 166  
Infotainment - accessory 168  
Service indication (SERVICE) 176  
Indication of Oil Service, Date Service and Desmo Service COUNT DOWN 177  
Indication of Oil Service, Date Service and Desmo Service 178  
DRL automatic mode indication - accessory 179  
Viewing side stand status 180  
Warnings and Alarms 181  
Errors 185  
Light control 186  
Immobilizer system 193  
Keys 194  
Key duplication 195  
Restoring motorcycle operation via the PIN CODE 196

## **Controls 198**

Position of motorcycle controls 198  
Key-operated ignition switch and steering lock 199  
Left-hand switch 200  
Clutch lever 201

Right-hand switch 202  
Throttle twistgrip 203  
Front brake lever 204  
Rear brake pedal 205  
Gear change pedal 206  
Adjusting the position of the gearchange pedal and rear brake pedal 207

## **Main components and devices 209**

Position on the vehicle 209  
Tank filler plug 210  
Seat lock 211  
Side stand 214  
Front fork adjustment 215  
Adjusting the rear shock absorber 217

## **Riding the motorcycle 219**

Running-in recommendations 219  
Pre-ride checks 221  
ABS device 223  
Starting the engine 224  
Moving off 226  
Braking 227  
Anti-Lock Braking System (ABS) 227

Stopping the motorcycle 229  
Parking 230  
Refuelling 231  
Tool kit and accessories 234

## Main use and maintenance operations 237

Checking coolant level and topping up, if necessary 237  
Check clutch and brake fluid level 238  
Checking brake pads for wear 240  
Charging the battery 241  
Checking drive chain tension 245  
Lubricating the drive chain 247  
Replacing the headlight bulbs 252  
Changing the turn indicator bulbs 255  
Number plate light 257  
Aligning the headlight 258  
Adjusting the rear-view mirrors 260  
Tubeless tyres 261  
Check engine oil level 263  
Cleaning and replacing the spark plugs 266  
Cleaning the motorcycle 267  
Storing the motorcycle 268  
Important notes 269

Scheduled maintenance chart 270  
Scheduled maintenance chart: operations to be carried out by the dealer 270  
Scheduled maintenance chart: operations to be carried out by the Customer 274

## Technical data 275

Weights 275  
Dimensions 276  
Fuel, lubricants and other fluids 277  
Engine 279  
Timing system 280  
Performance data 281  
Spark plugs 281  
Fuel system 281  
Brakes 281  
Transmission 282  
Frame 283  
Wheels 283  
Tyres 283  
Suspension 283  
Exhaust system 284  
Available colours 284  
Electric system 285

**Routine maintenance record 291**

Routine maintenance record 291



# Introduction

## Safety guidelines

We would like to welcome you among Ducati enthusiasts, and congratulate you on your excellent choice of motorcycle. We think you will ride your Ducati motorcycle for long journeys as well as short daily trips. Ducati Motor Holding S.p.A. wishes you smooth and enjoyable riding.

Your motorcycle is the result of Ducati Motor Holding S.p.A.'s on-going research and development efforts. It is important that you preserve its quality standard by strictly observing the maintenance plan and using genuine spare parts. This manual provides instructions on minor maintenance operations. Major maintenance operations are described in the Workshop Manual available to Ducati Authorised Service Centres. In your own interest, for your safety and in order to guarantee product reliability, you are strongly advised to refer to our authorised Dealers and

Service Centres for any operations listed in the scheduled maintenance chart, see page 270.

Our highly skilled staff have access to special implements and appropriate equipment required to perform any servicing job at best, and use Ducati original spare parts only as the best guarantee for full interchangeability, smooth running and long life.

All Ducati motorcycles come with a Warranty Card. The warranty does not apply to motorcycles used in racing competitions.

Tampering with or altering any components, even partially, will make the warranty null and void effective immediately. Improper or poor maintenance, using other than original spare parts or parts not expressly approved by Ducati may invalidate your warranty rights and lead to damage or loss of performance.

Your safety and that of other road users are very important. Ducati Motor Holding S.p.A. recommends that you ride responsibly. Before using your motorcycle for the first time, read this entire manual carefully and closely follow the guidelines outlined in it. The manual provides full information on proper motorcycle operation and

maintenance. In case of any doubts, please contact a Dealer or Authorised Service Centre.

The terms RIGHT and LEFT are referred to the motorcycle viewed from the riding position.

## Warning symbols used in the manual

Several kinds of warnings are used as an alert of the possible hazards for you or other persons such as:

- Safety labels on the motorcycle;
- Safety messages preceded by a warning symbol and either WARNING or IMPORTANT.

### **Attention**

Failure to comply with these instructions may put you at risk, and could lead to severe injury or even death of the rider or other persons.

### **Important**

Possibility of damaging the motorcycle and/or its components.

### **Note**

Additional information about the current operation.

## Intended use



### Attention

This motorcycle is designed for on-road use, may be used occasionally on dirt trail. Usage in conditions for which it was not designed (e.g. heavy off-road use) can lead to loss of control of the motorcycle, increasing the risk of a crash.



### Attention

This motorcycle may not be used to tow any trailers or with a side-car attached; this can lead to loss of control and result in an accident.

This motorcycle carries the rider and can carry a passenger.



### Attention

The total weight of the motorcycle in running order including rider, passenger, luggage and additional accessories should not exceed 375 kg / 826.73 lb.



## Important

Using the motorcycle under extreme conditions, such as very damp and muddy roads or dusty and dry environment, could cause above-average wear of components like the drive system, the brakes or the air filter. If the air filter is dirty, the engine could get damaged. Therefore, this might translate in required service or replacement of the wear parts earlier than specified in the scheduled maintenance chart.

## Rider's obligations

All riders must hold a valid licence.



### Attention

Riding without a licence is illegal and is prosecuted by law. Always make sure you have your licence with you when riding. Do not let inexperienced riders or persons without a valid licence use your motorcycle.

Do not ride under the influence of alcohol and/or drugs.



### **Attention**

Riding under the influence of alcohol and/or drugs is illegal and is prosecuted by law.

Do not take prescription or other drugs before riding unless you have consulted your doctor about their side effects.



### **Attention**

Some medications and drugs may cause drowsiness or other effects that slow down reaction time and the rider's ability to control the motorcycle, possibly leading to an accident.

Some states require vehicle insurance.



### **Attention**

Check your state laws. Obtain insurance coverage and keep your insurance document secure with the other motorcycle documents.

To protect rider and passenger safety, some states mandate the use of a certified helmet.



### **Attention**

Check your state laws. Riding without a helmet may be punishable by law.



### **Attention**

Riders without helmets are more likely to suffer severe bodily injury or die if they are in an accident.



### **Attention**

Check that your helmet complies with safety specifications, permits good vision, is the right size for your head, and carries a certification label indicating that it conforms to the standards in force in your state. Road traffic laws differ from state to state. Learn about traffic laws in your state before riding and always obey them.

## **Rider's training**

Accidents are frequently due to inexperience. Riding, manoeuvres and braking must be performed in a different way than on the other vehicles.



## Attention

Untrained riders or a wrong use of the vehicle may lead to loss of control, serious injuries or even death.

## Apparel

Riding gear is very important for safety. Unlike cars, a motorcycle offers no impact protection in an accident.

Proper riding gear includes helmet, eye protection, gloves, boots, long sleeve jacket and long trousers.

- The helmet must meet the requirements listed at page 10; if your helmet does not have a visor, use suitable eye wear;
- Use five-finger gloves made from leather or abrasion-resistant material;
- Riding boots or shoes must have non-slip soles and offer ankle protection;
- Jacket, trousers or riding suit must be made from leather or abrasion-resistant material and have high-visibility colours and inserts.



## Important

Never wear loose clothing, items or accessories that may become tangled in motorcycle parts.



## Important

For your safety, always wear suitable protective gear, regardless of season and weather.



## Important

Have your passenger wear proper protective clothing.

## Safety "Best Practices"

These few simple operations are critical to people safety and to preserving the full performance of your motorcycle. Never forget to perform them before, while and after riding.

### Important

Closely follow the indications provided at chapter "Riding the motorcycle" during the running-in period.

Failure to follow these instructions releases Ducati Motor Holding S.p.A. from any liability whatsoever for any engine damage or shorter engine life.

### Attention

Before riding your motorcycle, become familiar with the controls you will need to use when riding.

Perform the checks recommended in this manual before each ride (see page 221).

### Attention

Failure to carry out these checks before riding may lead to motorcycle damage and injury to rider and/or passenger.

### Attention

Start the engine outdoors or in a well ventilated area. The engine should never be started or run indoors.

Exhaust gases are poisonous and may lead to loss of consciousness or even death within a short time. Use proper body position while riding and ensure your passenger does the same.

### Important

Rider must hold the handlebar with both hands at ALL TIMES while riding.

### Important

Both rider and passenger should keep their feet on the footpegs when the motorcycle is in motion.

### Important

The passenger should always hold on to the grab handles under the seat with both hands.



### **Important**

Be very careful when tackling road junctions, or when riding in areas near exits from private grounds, car parks or on slip roads to access motorways.



### **Important**

Be sure you are clearly visible and do not ride within the blind spot of vehicles ahead.



### **Important**

ALWAYS signal your intention to turn or pull to the next lane in good time using the suitable turn indicators.



### **Important**

Park your motorcycle where no one is likely to knock against it, and use the side stand. Never park on uneven or soft ground, or your motorcycle may fall over.



### **Important**

Visually inspect the tyres at regular intervals for detecting cracks and cuts, especially on the side walls, bulges or large spots that are indicative of internal damage. Replace them if badly damaged. Remove any stones or other foreign bodies caught in the tread.



### **Attention**

Engine, exhaust pipes and silencers stay hot long after the engine is switched off; pay particular attention not to touch the exhaust system with any body part and do not park the vehicle next to flammable material (wood, leaves etc.).



### **Attention**

Always remove the key when you leave your motorcycle unattended and make sure it is not accessible to persons not authorised to use the motorcycle.

## Refuelling

### Fuel label

Fuel identification label

Refuel outdoors with engine off.

Do not smoke or use open flames while refuelling. Be careful not to spill fuel on engine or exhaust pipe. Never completely fill the tank when refuelling. Fuel should never be touching the rim of filler recess. When refuelling, avoid breathing the fuel vapours and prevent fuel from reaching your eyes, skin or clothes.

### Attention

The motorcycle is only compatible with fuel having a maximum content of ethanol of 10% (E10). Using fuel with ethanol content over 10% is forbidden. Using it could result in severe damage of the engine and motorcycle components. Using fuel with ethanol content over 10% will make the warranty null and void.

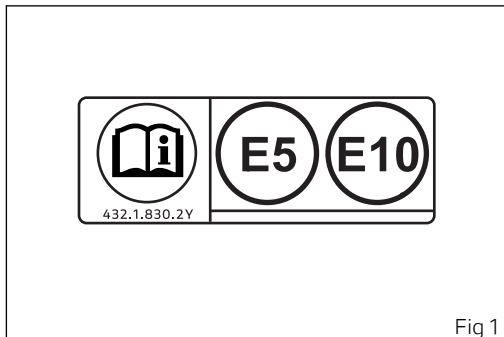

Fig 1

### Attention

In case of indisposition caused by breathing fuel vapours for a long time, stay in the open air and contact your doctor. In case of contact with eyes, thoroughly flush with water; in case of contact with skin, immediately clean with water and soap.

### Attention

Fuel is highly flammable, in case of accidental spillage of fuel on your clothes it is necessary to change into clean clothes.



## Carrying the maximum load allowed

Your motorcycle is designed for long-distance riding, carrying the maximum load allowed in full safety. Even weight distribution is critical to preserving these safety features and avoiding trouble when performing sudden manoeuvres or riding on bumpy roads.

### Attention

The maximum speed permitted with the side bags and top case fitted must not exceed 180 km/h (112 mph) and at any rate it must comply with the applicable statutory speed limits.

### Attention

Do not exceed the total permitted weight for the motorcycle and pay attention to information provided below regarding load capacity.

## Information about carrying capacity

### Important

Arrange your luggage or heavy accessories in the lowest possible position and close to motorcycle centre.

### Important

Never fix bulky or heavy objects to the handlebar or to the front mudguard as this would affect stability and cause danger.

### Important

Be sure to secure the luggage to the supports provided on the motorcycle as firmly as possible. Improperly secured luggage may affect stability.

### Important

Do not insert any objects you may need to carry into the gaps of the frame as these may foul moving parts.

### Attention

Make sure the tyres are inflated to the proper pressure and that they are in good condition.

Refer to paragraph "Tubeless tyres" on page 261.

## Dangerous products - warnings

Used engine oil

### Attention

Prolonged or repeated contact with used engine oil may cause skin cancer. If working with engine oil on a daily basis, we recommend washing your hands thoroughly with soap immediately afterwards. Keep away from children.

Brake dust

Never clean the brake assembly using compressed air or a dry brush.

Brake fluid

### Attention

Spilling brake fluid onto plastic, rubber or painted parts of the motorcycle may cause damages. Protect these parts with a clean shop cloth before proceeding to service the system. Keep away from children.

### Attention

The fluid used in the brake system is corrosive. In the event of accidental contact with eyes or skin, wash the affected area with abundant running water.

Coolant

Engine coolant contains ethylene glycol, which may ignite under particular conditions, producing invisible flames. Although the flames from burning ethylene glycol are not visible, they are still capable of causing severe burns.

### Attention

Take care not to spill engine coolant on the exhaust system or engine parts.

These parts may be hot and ignite the coolant, which will subsequently burn with invisible flames. Coolant (ethylene glycol) is irritant and poisonous when ingested. Keep away from children. Never remove the radiator cap when the engine is hot. The coolant is under pressure and will cause severe burns.

The cooling fan operates automatically: keep hands well clear and make sure your clothing does not snag on the fan.

## Battery



### **Attention**

The battery gives off explosive gases; never cause sparks or allow naked flames and cigarettes near the battery. When charging the battery, ensure that the working area is properly ventilated.

## Vehicle identification number



**Note** These numbers identify the motorcycle model and should always be indicated when ordering spare parts.

It is recommended to record the frame number of your motorcycle in the space below.

---

Frame number

---

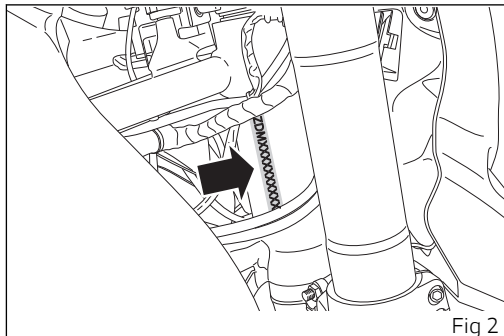

## Engine identification number



### Note

These numbers identify the motorcycle model and should always be indicated when ordering spare parts.

It is recommended to record the number of your motorcycle's engine in the space below.

---

Engine number

---

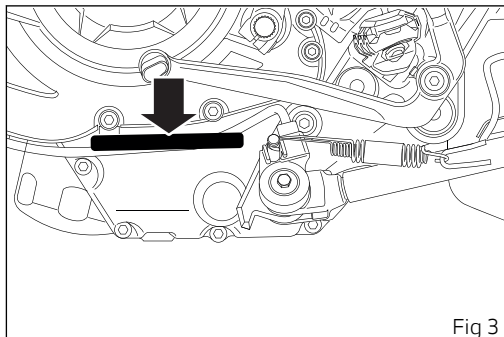

Fig 3

# Instrument panel (Dashboard)

## Instrument panel

1) DISPLAY

2) NEUTRAL LIGHT N (GREEN)

Comes on when in neutral position.

3) GENERIC ERROR WARNING LIGHT  (AMBER YELLOW)

It turns on when there are any "vehicle" errors, i.e. active errors triggered by any control unit other than the engine control unit.

4) HIGH BEAM LIGHT  (BLUE)

It turns on to indicate that the high beam lights are on and when the flasher is activated.

5) FUEL WARNING LIGHT  (AMBER YELLOW)  
Comes on when fuel is low (see chapter "Top-ups").

6) TURN INDICATOR LIGHTS  (GREEN)

Illuminates and flashes when the turn indicator is in operation.

7) ENGINE OIL PRESSURE LIGHT  (RED)

Comes on when engine oil pressure is too low. It must turn on at "KEY-ON", but must turn off a few seconds after the engine has started. It may shortly come on when the engine is hot, however, it should go out as the engine revs up.



### Important

If the ENGINE OIL light stays ON, stop the engine or it may suffer severe damage.

8) DTC/DWC STATUS LIGHT (AMBER YELLOW)

This light indicates DTC/DWC system enabling/disabling status.

- Light off: DTC/DWC enabled and functioning;
- Light ON flashing: DTC/DWC enabled, but with degraded performance;
- Light steady ON: DTC/DWC disabled and/or not functioning due to a fault in the control unit.

9) ENGINE DIAGNOSIS - MIL LIGHT  (AMBER YELLOW)

It turns on in the case of "engine" errors that in some cases will lock the engine.

### 10) ABS LIGHT (AMBER YELLOW)

Indicates ABS status.

- Light off: ABS enabled and functioning;
- Light ON flashing: ABS in self-diagnosis and/or functioning with degraded performance;
- Light steady ON: ABS disabled and/or not functioning due to a fault in the ABS control unit.

### 11) DTC/DWC INTERVENTION (AMBER YELLOW)

- Light OFF: no DTC intervention.
- Light steady ON: DTC intervention.

### 12) OVER REV SIDE LIGHTS

The lights turn on when RPM value reaches the first threshold before the rpm limiter kicks in.

### 13) OVER REV / IMMOBILIZER SYSTEM

Over rev:

- Light OFF: no limiter intervention;
- Light ON flashing: limiter intervention.



### Note

Each calibration of the Engine Control Unit may have a different setting for the thresholds that precede the rev limiter and the rev limiter itself.

Immobilizer:

- Light OFF: key-on status or key-off status for over 12 hours;
- Light ON flashing: key-off status;

### 14) DRL LIGHT (GREEN)

Indicates DRL lights status (not present in China, Canada and Japan versions).

- Light OFF: DRL light off;
- Light steady ON: DRL light active;
- Light ON flashing: DRL light in fault.



### Important

If the display shows the message "TRANSPORT MODE", immediately contact your Ducati Dealer that will delete this message and ensure the full operation of the motorcycle.

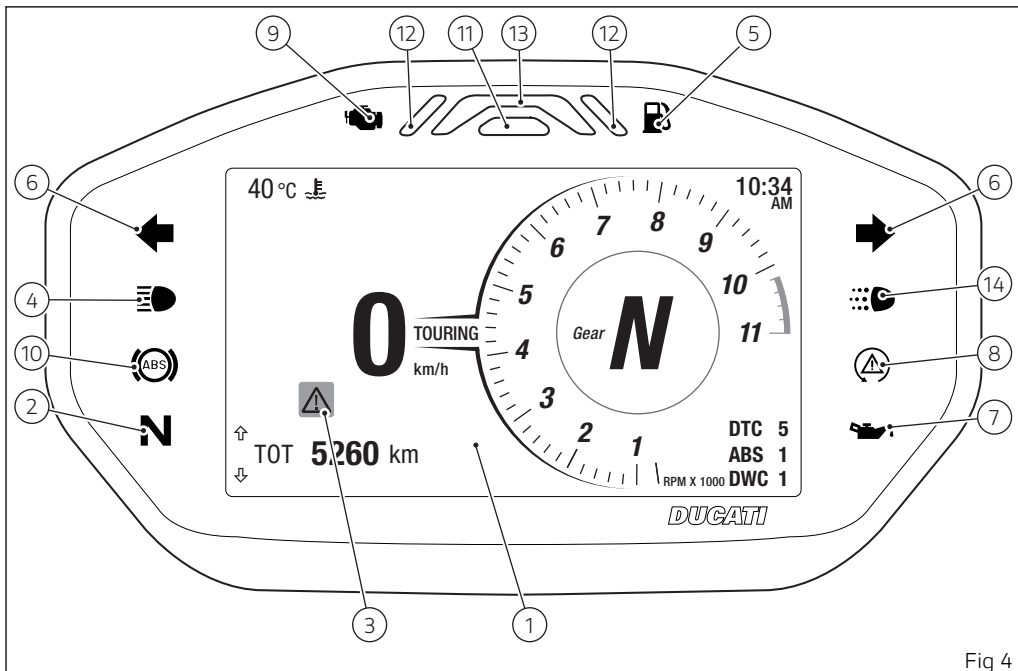

Fig 4



## Acronyms and abbreviations used in the Manual

Global Positioning System

ABS

Anti-lock Braking System

BBS

Black Box System

CAN

Controller Area Network

EBC

DUCATI rear tyre Anti-locking System by ETV

DDA

DUCATI Data Acquisition

DQS

DUCATI Quick Shift

DRL

Daytime Running Lamp

DSB

Dashboard

DTC

DUCATI Traction Control

DWC

DUCATI Wheelie Control

ECU

Engine Control Unit

GPS

## Technological Dictionary

### Ducati Traction Control (DTC)

The Ducati Traction Control system (DTC) supervises the rear wheel slipping control and settings vary through eight different levels that are calibrated to offer a different tolerance level to rear wheel slipping. Each Riding Mode features a pre-set intervention level. Level 8 indicates system intervention whenever a slight slipping is detected, while level 1 is for off-road use and very expert riders because it is less sensitive to slipping and intervention is hence softer.

### Ducati Wheelie Control (DWC)

The Ducati Wheelie Control system (DWC) supervises control of wheelie movement and settings vary through eight different levels that are calibrated to offer a different prevention and reaction to wheelies. Each Riding Mode features a pre-set intervention level. Level eight indicates a setting that minimises motorcycle tendency to shift up in a wheelie and maximises reaction to the same, if it occurs. While level one is for expert riders and features a lower wheelie control in terms of

prevention and less strong reaction to the same, if it occurs.

### Anti-lock Braking System (ABS)

Using the brakes correctly under adverse conditions is the hardest – and yet the most critical – skill to master for a rider. Braking is one of the most difficult and dangerous moments when riding a two wheeled motorcycle: the possibility of falling or having an accident during this difficult moment is statistically higher than any other moment. A locked front wheel leads to loss of traction and stability, resulting in loss of control. The Anti-Lock Braking System (ABS) has been developed to enable riders to use the motorcycle braking force to the fullest possible amount in emergency braking or under poor pavement or adverse weather conditions. ABS is an electro-hydraulic device that controls the pressure in the brake circuit when the control unit, by processing information from wheel sensors, determines that one or both wheels are about to lock up. In this case, pressure decrease in the brake circuit allows the wheel to carry on turning, thereby preserving grip. After that, the control unit restores the pressure in the brake circuit, to resume the braking action. This cycle is repeated many times until the problem is

completely eliminated. Normally, the rider will perceive ABS operation as a harder feel or a pulsation of the brake lever and pedal. The front and rear brakes use separate control systems. The ABS system fitted to the Hypermotard 950 and Hypermotard 950 SP is a safety system preventing wheel lockup while braking, adopting different strategies depending on the selected level. The active presence of strategies and their intervention level depend on the selected level. The ABS features 3 levels, one associated to each Riding Mode. The ABS system fitted to the Hypermotard 950 and Hypermotard 950 SP features a "cornering" function that optimises ABS functionality to the conditions where the motorcycle is leaning over, thus preventing wheel lockup and slipping as much as possible, within the physical limits allowed by the vehicle and by the road conditions. The cornering function is active on all the ABS levels. According to the selected level, the ABS can implement the anti lift-up function for the rear wheel so as to guarantee not only a reduced stopping distance under braking, but also the highest possible stability.

### Ducati Quick Shift (DQS)

The DQS with up/down feature allows the rider to upshift and downshift without using the clutch lever. It includes a two-way microswitch - built in the lever mechanism - that outputs a signal to the engine control unit whenever the gearshift is operated. The system works in a different way when upshifting and downshifting.

## Information statement on UE directive 2014/53/UE

Simplified EU declaration of conformity

Your vehicle is equipped with a range of radio equipment. The manufacturers of this radio equipment declare that this radio equipment complies with Directive 2014/53/EU where required by law.

The complete text of the EU declaration of conformity is available at the following web address:  
[certifications.ducati.com](http://certifications.ducati.com)

### Manufacturers' addresses

All relevant components pursuant to 2014/53/EU must bear the manufacturer's address. For components that, due to their size or nature, cannot be furnished with a sticker, the respective manufacturers' addresses as required by law are listed here:

Radio equipment installed in the vehicle	Manufacturers' addresses
Bluetooth / DSB	COBO S.p.a. Via Tito Speri, 10 25024 - Leno (BS) Italy
Hands free	ZADI S.p.a. Via Carl Marx, 138 41012 - Carpi (MO) Italy
Hands free	ASHAI DENSO 6-2-1 Somejidai, Hamakita-ku, Hamamatsu, Shizuoka 434-0046 Japan
Djair®	Dainese S.p.a. Via dell'Artigianato, 35 36060 - Molvena (VI) Italy
E-Lock	ZADI S.p.a. Via Carl Marx, 138 41012 - Carpi (MO) Italy
GPS	PROSA S.r.l. Via dell'Elettricità, 3/d 30175 - Venezia Marghera (VE) Italy

<b>DSB</b>	<b>MAE</b> Via Presolana 31/33 24030 Medolago – Bergamo - Italy
<b>DSB</b>	<b>EGICON</b> Via Posta Vecchia, 36, Mirandola (MO) - Italy
<b>TPMS</b>	<b>LDL Technology S.A.S.</b> Parc Technologique du Canal, 3 rue Giotto 31520 Ramonville - France
<b>TPMS</b>	<b>PACIFIC Industrial Co., Ltd.</b> 1300-1 Yokoi, Godo-cho, Anpachi-gun, Gifu 503-2397, JAPAN
<b>Anti-theft system</b>	<b>PATROLLINE</b> Via Cesare Cantù, 15/C Albavilla (CO) - Italy

Radio equipment	Frequency band	Max. transmission power
Bluetooth	2,402 MHz ÷ 2,480 MHz	4.4 mW
Hands free unit	134.2 KHz (AD) 134.5 KHz (Zadi) (129.6 – 135 kHz)	73 dB $\mu$ V/m (10 m) < 66 dB $\mu$ A/m (10m)
Hands free key	868.35 MHz (Zadi) (868 – 868.5 MHz) 434 MHz (AD)	<25mW e.r.p. -20 dBm (3 m)
D air <sup>®</sup>	868 MHz 2.4 GHz	+10 dB +3 dB
E-Lock	134.5 KHz (129.6 – 135 kHz)	< 66 dB $\mu$ A/m (10m)
GPS	1575.4 MHz	
DSB	134.2 KHz 120 KHz – 140 KHz	178.5 dB $\mu$ A/m <66 dB $\mu$ A/m (10 m)
TPMS	868.35 MHz (LDL) 433.05 ÷ 434.79MHz (Pacific)	-7 dBm +/- 4 dB 100 dB $\mu$ V/m
Anti-theft system	433.92MHz ( $\pm$ 75KHz)	<0.6 mA

## Function buttons

1) UP CONTROL SWITCH " ⬆ " (MENU navigation)

Button used to display and set instrument panel parameters with the position " ⬆ ".

2) DOWN CONTROL SWITCH " ⬇ " (MENU navigation)

Button used to display and set instrument panel parameters with the position " ⬇ ".

3) HIGH-BEAM FLASH/LAP BUTTON

The high-beam flash button may also be used for LAP functions.

4) TURN INDICATORS ACTIVATION / CONFIRM MENU BUTTON " ○ "

The turn indicators activation button may also be used for the CONFIRM MENU function " ○ ".

5) DRL BUTTON (accessory)

Button used to switch on/off the DRL.

6) HAZARD BUTTON

Button used to switch on/off all four turn indicators (Hazard function).

7) LOW / HIGH BEAM BUTTON

Button used to switch on/off the low and high beams.

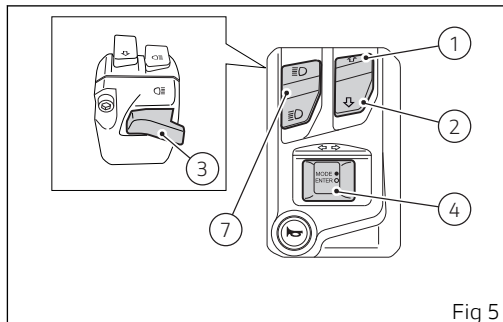

Fig 5

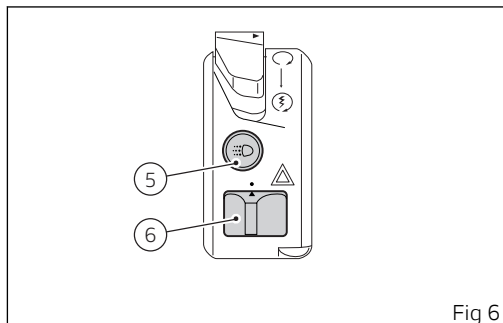

Fig 6

## Parameter displaying

Upon key-on, the instrument panel displays the DUCATI logo and carries out a sequential check of the LED warning lights.

After this routine, the instrument panel displays the main page in one of the available layouts (SPORT, TOURING, URBAN), depending on the one in use before last KEY-OFF.

During this first check stage, if the motorcycle speed exceeds 10 km/h (6 mph) (actual speed), the instrument panel will immediately stop warning light and display check routine and display the main screen.

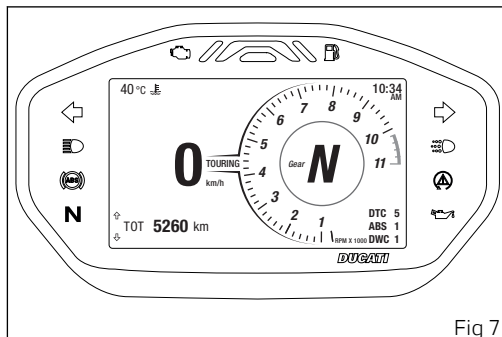

Fig 7



There are three different main pages, each associated with the corresponding riding mode: SPORT, TOURING, URBAN.

The differences between the pages are the name and colour of the riding mode specified at the centre of the display and the colour of the rpm box:

- red for the SPORT Riding mode (A)
- black in DAY mode or white in NIGHT mode (see page 131) for the TOURING riding mode (B)
- grey for the URBAN riding mode (C)

Data displayed on all types of main screen are as follows:

- 1) Motorcycle speed
- 2) Engine Coolant temperature
- 3) Set Riding Mode
- 4) Gear indication
- 5) Rev counter
- 6) Clock
- 7) Parameter indicators also showing the values associated with the set riding mode
- 8) Function menu
- 9) LAP time (Lap) - if activated
- 10) Bluetooth indication (only if Bluetooth is available and active)

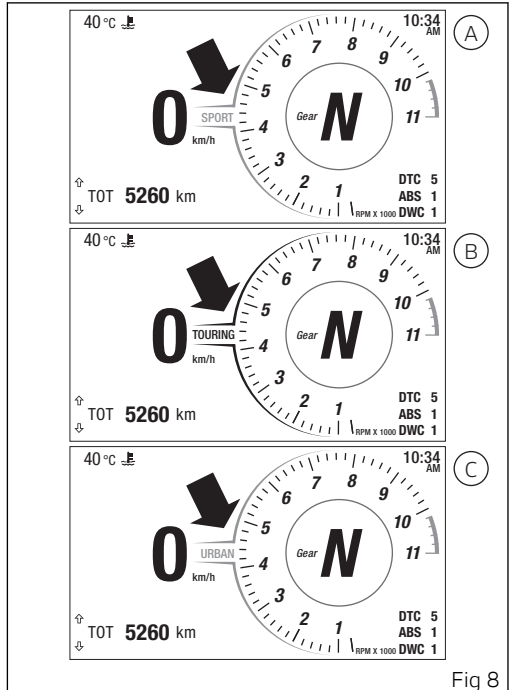

Fig 8

- 11) Indication of missed calls or received sms / mms / e-mails (only if Bluetooth is active and a smartphone is connected)
- 12) Connected device indication (only if Bluetooth is available and active)
- 13) Status of DRL Lights (Auto, Manual or disabled) / Low Beams (active / not active): in this area DRL and Low Beams warning lights alternate (DRL lights are not present in China, Canada and Japan versions).
- 14) Heated handgrips (if any)

Further details that can be displayed only if the relevant function is active are the following:

- Warning/Alarm indication (Warning)
- Side stand status (Side Stand)
- SERVICE indication
- SERVICE count-down indication

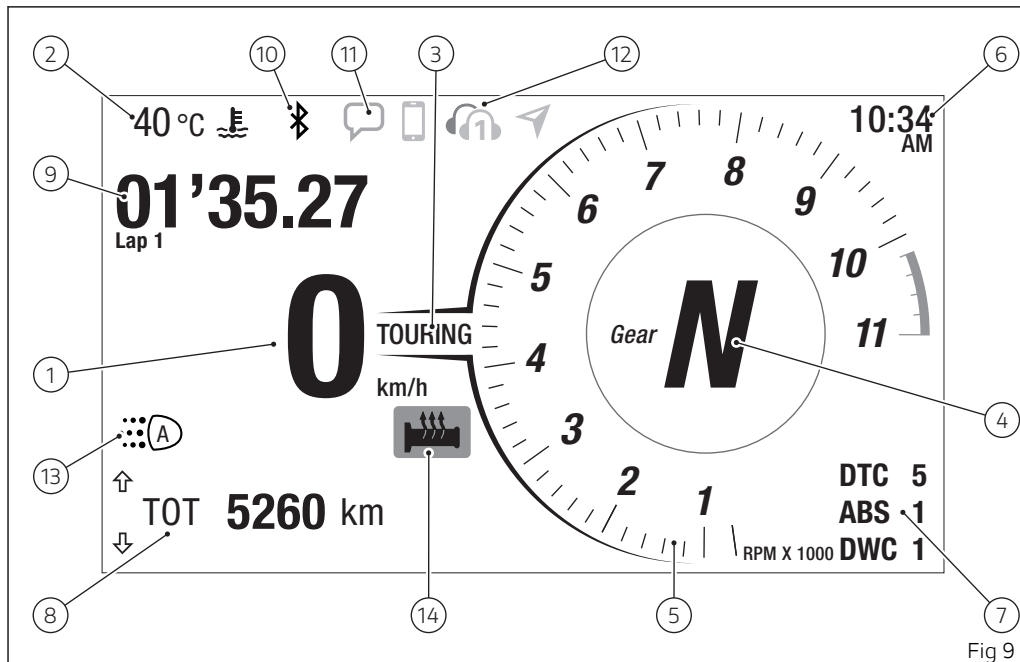

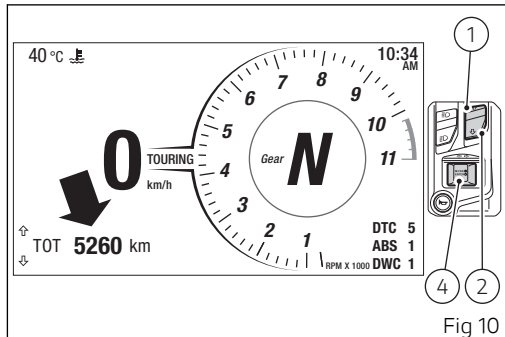



Fig 9

From the main screen, press button (1) or (2) on LH switch to scroll through menu information:

- Odometer (TOT)
- Trip meter 1 (TRIP 1)
- Average Fuel Consumption 1 (CONS.AVG 1)
- Average speed 1 (SPEED AVG 1)
- Trip time 1 (TRIP TIME 1)
- Ambient air temperature (T AIR)
- Partial fuel reserve counter (TRIP FUEL)
- Trip meter 2 (TRIP 2)
- Instantaneous fuel consumption (CONS.)
- Music player management (PLAYER OFF - PLAYER ON) – only if the Bluetooth module is present and at least 1 smartphone is connected
- Call management (LAST CALLS) – only if the Bluetooth module is present and at least 1 smartphone is connected.
- Heated handgrips (HEATING GRIPS) – accessory
- Setting menu (SETTING MENU)

The UP  and DOWN  arrows - corresponding to button (1) and button (2) on LH switch - appear on the RH side of the menu indicating the possibility to scroll through the functions. The empty circle



symbol  is displayed when it is possible to interact with the displayed function by pressing button (4) on LH switch, for instance to reset trip meter 1 (TRIP 1, page 71).

The instrument panel stores menu current settings upon KEY-OFF.

Upon next KEY-ON, the instrument panel displays the "Odometer" function for 10 seconds in the Menu and then displays the function previously saved upon KEY-OFF.

During these first 10 seconds, if button (1) or button (2) is pressed, the "forced" 10-second view of the

Odometer (TOT) is interrupted and the function previously saved upon KEY-OFF will be displayed.

In case of sudden and unexpected power OFF, the instrument panel displays the odometer (TOT) function in the menu upon the following KEY-ON.

## Main and auxiliary functions

The functions displayed in the Standard screen are the following:

### Main information

- Motorcycle speed
- Engine rpm indication
- Engine Coolant temperature
- Clock
- Gear indication
- Set Riding Mode
- Parameters linked to set riding mode:
  - DQS (accessory)
  - DTC
  - ABS
  - DWC

- Function menu:
  - Odometer (TOT)
  - Trip meter 1 (TRIP 1)
  - Average Fuel Consumption 1 (CONS.AVG 1)
  - Average speed 1 (SPEED AVG 1)
  - Trip time 1 (TRIP TIME 1)
  - Ambient air temperature (T AIR)
  - Partial fuel reserve counter (TRIP FUEL)
  - Trip meter 2 (TRIP 2)
  - Instantaneous fuel consumption (CONS.)
  - Music player management (PLAYER OFF - PLAYER ON) – only if the Bluetooth module is present and at least one smartphone is connected
  - Call management (LAST CALLS) – only if the BT module is present and at least one smartphone is connected
  - Heated handgrips (HEATING GRIPS)
  - Setting menu (SETTING MENU)

The functions within the Setting Menu that can be modified by the user are the following:

- Riding Mode customisation: within this menu, rider can customise the following:
  - engine setting (Engine)
  - DTC setting (DTC)
  - ABS setting (ABS)
  - DWC setting (DWC)
  - DQS setting (DQS) - accessory
  - restore values (Default)
  - restore all values for all riding modes (All Default)
- PIN CODE activation and modification (Pin Code)
- Lap time (Lap)
- backlighting setting (Backlight)
- date and time setting (Date and Clock)
- unit of measurement setting (Units)
- service information (Service)
- tyre setting and drive ratio (Tyre Calibration)
- DRL mode setting - accessory (DRL Control)
- Bluetooth device settings - accessory (Bluetooth)
- turn indicator mode setting (Turn indicators)
- information (Info)
- Infotainment - accessory
- Lap time (LAP)
- Service indication (SERVICE)
- Indication of Oil Service, Date Service and Desmo Service COUNT DOWN
- Indication of Oil Service, Date Service and Desmo Service
- Warnings and Alarms
- DRL AUTO / MANUAL indication - accessory
- Viewing side stand status
- Errors

Additional information

## Vehicle speed indication

The instrument panel receives information about the actual vehicle speed (calculated in km/h) and displays the value increased by 5% and converted in the set unit of measurement (mph or km/h).

A string of three dashes "- - -" is displayed with the set unit of measurement if:

- speed is higher than 299 km/h (186 mph) or instrument panel is not receiving the speed value ("- - -" steady on);
- the rear speed sensor is in fault (flashing "- - -").

### Note

If the instrument panel does not receive any information on the unit of measurement, the last unit of measurement set is displayed flashing.

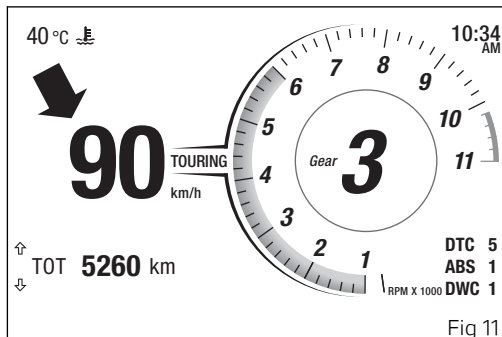

Fig 11



## Gear indication

The instrument panel receives information about the gear engaged and displays the corresponding value.

If a gear is engaged, the displayed value may range from 1 to 6, while if in neutral N is displayed and the Neutral warning light (2, Fig 4) turns on.

A dash "-" is displayed in these cases:

- dash "-" and Neutral (warning light 2, Fig 4) flashing on the instrument panel if the gear teach-in procedure has not been performed yet;
- dash "-" steady and Neutral (warning light 2, Fig 4) flashing on the instrument panel in case of gear sensor fault;
- dash "-" flashing if the instrument panel does not receive the gear information.

### Note

If the display shows "-" steady on and the Neutral light is off, then the gearbox could be in a mechanically unstable position; in such a case, up/downshift until the correct gear is indicated.

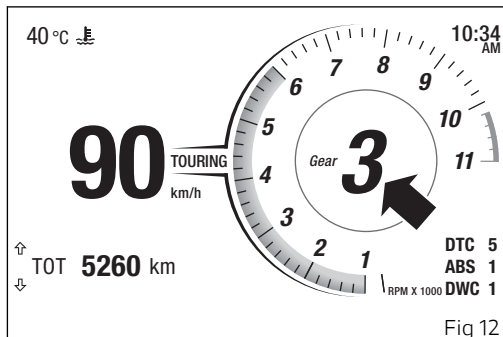

### Note

When the rpm indicator becomes amber yellow, the instrument panel is warning the rider to shift up.

## Engine rpm indication

The instrument panel receives the engine rpm information and displays it using a digital rev counter.

The rpm indicator wake is grey in DAY mode and white in NIGHT mode.

When the wake becomes amber yellow, the instrument panel is warning the rider to shift up.

The red wake flashes when the limiter (Over-rev) kicks in and the warning lights (12 and 13 Fig 4) turn on.

If the number of rpm is lower than 1,000, the wake is not displayed.

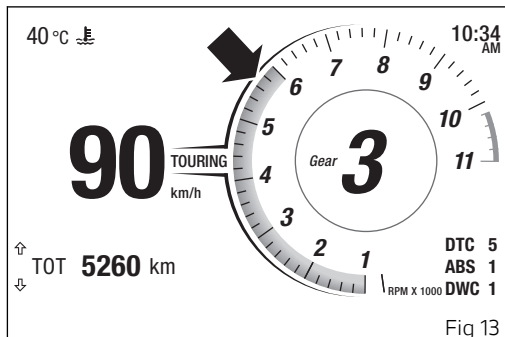

Fig 13

## DQS indicator - accessory

If DQS is installed, the instrument panel displays DQS status as follows:

- if DQS system is enabled, the indication to engage the gears "DQS U/D" is displayed;
- if DQS system is in reduced performance mode, the indication to engage the gears "DQS U/D" is displayed flashing;
- if the DQS system or the control unit is in fault, the "DQS Err" message is displayed in red;
- if DQS system is disabled, "DQS OFF" is displayed.

The DQS with up/down feature allows the rider to upshift and downshift without using the clutch lever. It includes a two-way microswitch - built in the lever mechanism - that outputs a signal to the engine control unit whenever the gearshift is operated. The system works in a different way when upshifting and downshifting.

Here below are some tips that will ensure you properly exploit this feature:

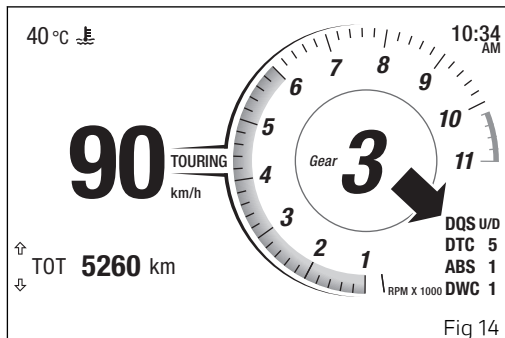

Fig 14

- The Ducati Quick Shift takes the same shift lever operation as with vehicle not equipped with the Ducati Quick Shift. Ducati Quick Shift is not designed for shifting automatically.

- For any gearshift request (upshifting or downshifting) the rider has to move the shift lever from its idle position in the desired direction against the force of the spring through a certain over-travel, then keep the shift lever in this position until the gearshift is completed. Once the gearshift has been completed, the lever has to be fully released in order to allow another gearshift acted by Ducati Quick Shift. If the rider does not move the shift lever up to end stroke during a Ducati Quick Shift request, gears may not be fully engaged.
- Ducati Quick Shift provides no assistance for the gearshift if the rider uses the clutch lever: the Ducati Quick Shift does not work when the clutch lever is pulled.
- Ducati Quick Shift will shift down (downshifting) only when the throttle control is completely closed.
- If the Ducati Quick Shift strategy does not work it is always possible to complete the gear shifting using the clutch lever.
- If the gear lever is held pressed up or down for more than 30 seconds (even if just by accident) a plausibility error can be memorised in the electronic control unit and the Ducati Quick Shift system could be disabled; in this case, to reactivate the system, it is necessary to release the lever, switch the instrument panel off, wait for 5 minutes and switch the instrument panel on again.
- Ducati Quick Shift is designed to operate above 2,500 rpm.
- No matter the gear engaged, downshifting with Ducati Quick Shift (downshifting) only works below a set threshold, so as to avoid exceeding the maximum rpm allowed when the lower gear is engaged.

## DTC indicator

The instrument panel displays DTC status as follows:

- if the DTC is active, the message "DTC" and the set intervention level number "1" to "8";
- if DTC is active, but system is in degraded operation, "DTC" indication and the number, "1" to "8" (flashing); also the DTC/DWC warning light (8, Fig 4) starts flashing;
- when in fault, the "DTC" indication and the red "Err" message; also the DTC/ DWC light (8, Fig 4) turns on steady;
- if the DTC is disabled, the "DTC" indication and "Off" message; also the DTC/DWC warning light (8, Fig 4) turns on.

### Attention

In case of system malfunction, contact a Ducati Dealer or Authorised Service Centre.

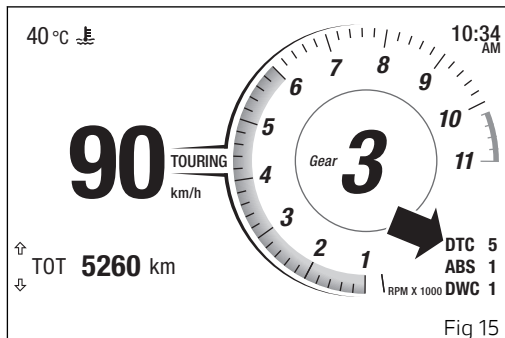

Fig 15



### Attention

DTC is a rider aid that can be used on the track, on the road and off road. The system is designed to make riding easier and to enhance safety, but in no way relieves the rider of the obligation to drive responsibly and to maintain a high standard of riding in order to avoid accidents, whether caused by his own errors or those of other road users, through making emergency manoeuvres, in accordance with the prescriptions of the road traffic code.

The rider must always be aware that active safety systems have a preventive function. The active elements help the rider control the motorcycle, making it as easy and safe to ride as possible. The presence of an active safety system should not encourage the rider to ride at speeds beyond the reasonable limits, not in accordance with the road conditions, the laws of physics, good riding standards and the requirements of the road traffic code.

The following table indicates the most suitable level of DTC intervention for the different riding modes as well as the default settings in the "Riding Modes" that can be selected by the rider:

DTC LEVEL	RIDING MODE	USE	DEFAULT
OFF		The DTC is disabled.	NO
1	TRACK Professional	Track use for very expert riders. System permits sliding sideways.	NO
2	TRACK	Very sporty style on the road and on the track, for experienced riders.	NO
3	SPORT	Sporty driving on a road or track.	It is the default level for the "SPORT" Riding Mode
4	TOURING	Extra-urban touring style.	It is the default level for the "TOURING" Riding Mode
5	CRUISE	Touring style for long travels.	NO
6	URBAN	City style.	It is the default level for the "URBAN" Riding Mode
7	RAIN	Wet or moist road.	NO
8	HEAVY RAIN	Wet road with pouring rain or very slippery asphalt.	NO

## Tips on how to select the sensitivity level



### Attention

The 8 levels of the DTC system your motorcycle is equipped with were calibrated with original equipment tyres (make, model and size). The use of tyres of different size to the original tyres may alter the operating characteristics of the system.

System calibration is optimised for these tyres:

- Pirelli Diablo Rosso III – front 120/70 ZR17, rear 180/55 ZR17
- Pirelli Supercorsa SP v3 – front 120/70 ZR17, rear 180/55 ZR17

In the case of minor differences, such as for example, tyres of a different make and/or model than the OE ones, but with the same size (rear = 180/55-17; front = 120/70-17), it may be sufficient to simply select the suitable level setting from those available in order to restore optimal system operation.

If tyres of a different size class are used or if the tyre dimensions differ significantly from the original tyres, it may be that the system operation is affected to the point where none of the 8 available level

settings will give satisfactory results. In this case it is advisable to deactivate the traction control system.

If level 8 is selected, the DTC control unit will kick in at the slightest hint that the rear wheel is starting to spin. Between level 8 and level 1 there are other 8 intermediate levels.

DTC intervention gradually decreases from level 8 to level 1.

With levels 1 and 2, DTC control unit allows both rear tyre spinning and sliding sideways when exiting a turn; we recommend using these levels only on track and to very experienced riders.

The choice of the correct level depends on 3 main variables:

- 1) The grip (type of tyre, amount of tyre wear, the road/track surface, weather conditions, etc.);
- 2) The characteristics of the path/circuit (bends all taken at similar speeds or at very different speeds);
- 3) The riding mode (whether the rider has a "smooth" or a "rough" style).

Level depends on grip conditions



The choice of level setting depends greatly on the grip conditions of the track/path (see below, tips for use on the track and on the road).

### Level depends on type of track

If the track/path features bends all taken at similar speeds, it will be easier to find a level suitable for all bends; while a track/path with a hairpin turn to be taken at very low speed compared to the other bends will require a DTC level setting that is the best compromise for all bends (on hairpin turn, DTC intervention will always be greater compared to the other bends).

### Level depends on riding style

The DTC will tend to kick in more with a "smooth" riding style, where the motorcycle is leaned over further, rather than with a "rough" style, where the motorcycle is straightened up as quickly as possible when exiting a turn.

### Tips for use on the track

We recommend that level 6 is used for a couple of full laps (to allow the tyres to warm up) and in order to get used to the system. Then try levels 5, 4 etc., in succession until you identify the DTC sensitivity level

that suits you best (always try each level for at least two laps to allow the tyres to warm up).

Once you have found a satisfactory setting for all the corners except one or two slow ones, where the system tends to kick in and control too much, you can try to modify your riding style slightly to a more "rough" approach to cornering i.e. straighten up more rapidly on exiting the corner, instead of immediately trying a different level setting.

### Tips for use on the road

Activate the DTC, select DTC 6 and ride the motorcycle in your usual style; if the level of DTC sensitivity seems excessive, try DTC level 5; if also this RM sensitivity seems excessive try DTC level 4. If none of the level suits your riding style, you can select the level by following the indications given on the previous table until finding the intervention level you prefer.

If changes occur in the grip conditions and/or circuit characteristics and/or your riding style, and the level setting is no longer suitable, switch to the next level up or down and proceed to determine the best setting (e.g. if with level 7 the DTC intervention seems excessive, switch to level 6; alternatively, if on

level 7 you cannot perceive any DTC intervention, switch to level 8).

## ABS indicator

The instrument panel displays ABS status as follows:

- the message “ABS” and the set intervention level number “1” to “3”;
- the message “ABS” and the set intervention level number and the flashing ABS light (10, Fig 4) when the system is running a self-diagnosis
- if ABS is in degraded operation due to a fault, “ABS” message and the set intervention level number (flashing); also the ABS warning light (10, Fig 4) starts flashing;
- when in fault, the “ABS” indication, the red "Err" message; also the ABS warning light (10, Fig 4) turns on;

### Attention

In case of system malfunction, contact a Ducati Dealer or Authorised Service Centre.

Using the brakes correctly under adverse conditions is the hardest – and yet the most critical – skill to master for a rider. Braking is one of the most difficult

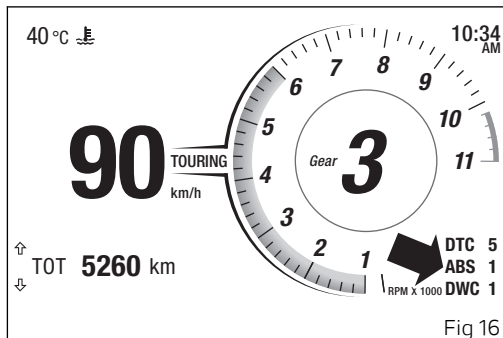

and dangerous moments when riding a two wheeled motorcycle: the possibility of falling or having an accident during this difficult moment is statistically higher than any other moment. A locked front wheel leads to loss of traction and stability, resulting in loss of control.

The Anti-Lock Braking System (ABS) has been developed to enable riders to use the motorcycle braking force to the fullest possible amount in emergency braking or under poor pavement or adverse weather conditions.

ABS is an electro-hydraulic device that controls the pressure in the brake circuit when the control unit, by processing information from wheel sensors, determines that one or both wheels are about to lock up. In this case, pressure decrease in the brake circuit allows the wheel to carry on turning, thereby preserving grip.

After that, the control unit restores the pressure in the brake circuit, to resume the braking action. This cycle is repeated many times until the problem is completely eliminated. Normally, the rider will perceive ABS operation as a harder feel or a pulsation of the brake lever and pedal. The front and rear brakes use separate control systems.

The ABS system fitted to the Hypermotard 950 and Hypermotard 950 SP is a safety system preventing wheel lockup while braking, adopting different strategies depending on the selected level. The active presence of strategies and their intervention level depend on the selected level. The ABS features 3 levels, one associated to each Riding Mode.

The ABS system fitted to the Hypermotard 950 and Hypermotard 950 SP features a "cornering" function that optimises ABS functionality to the conditions where the motorcycle is leaning over, thus

preventing wheel lockup and slipping as much as possible, within the physical limits allowed by the vehicle and by the road conditions. The cornering function is active on all the ABS levels.

According to the selected level, the ABS can implement the anti lift-up function for the rear wheel so as to guarantee not only a reduced stopping distance under braking, but also the highest possible stability.

In ABS level 1, also the "slide control under braking" is active. Under some activation conditions, ensuring in any case the maximum rider safety, the ABS system allows more pronounced slipping at the rear allowing vehicle yaw or slide, so as to permit a more sporty and faster corner entry. This control activates when the user acts on the rear brake during a sufficiently strong braking also at the front. During the operation of this system, the ABS monitors vehicle slipping or slide level, so that it remains below a safety level, which depends on the lean angle. If vehicle slipping or slide level increases too much, the ABS operates again in standard mode, realigning the vehicle in order to always ensure the maximum safety.



## Attention

Using the two brake controls separately reduces the motorcycle braking power.

Using just one of the two brake controls separately means using the motorcycle braking power only partially.

Never use the brake controls harshly or suddenly as you may cause rear wheel lift-up and lose control of the motorcycle.

When riding in the rain or on slippery surfaces, braking will become less effective. Always use the brakes very gently and carefully when riding under these conditions. Any sudden manoeuvres may lead to loss of control. When tackling long, high-gradient downhill road tracts, shift down gears to use engine braking. Apply one brake at a time and use brakes sparingly. Keeping the brakes applied all the time would cause the friction material to overheat and reduce braking power dangerously.

Underinflated and overinflated tyres reduce braking efficiency, handling accuracy and stability in a bend.

The following table indicates the most suitable level of ABS intervention for the various riding types as well as the default settings in the "Riding Mode" that can be selected by the rider:

ABS LEVEL	RIDING MODE	CHARACTERISTIC	DEFAULT
1	TRACK	This level is designed for expert riders. ABS in this level controls both wheels and the cornering function is active; anti-lift-up control is not active. In this level, also the "slide control under braking" is active. This level privileges the braking power and is designed for riders knowing how to exploit full braking performance.	NO
2	SPORT	This level is designed for use with good grip conditions. ABS in this level controls both wheels and the cornering and anti-lift-up functions are active. This calibration focusses on braking power and yet keeps good stability under braking and lift-up control.	It is the default level for the "SPORT" riding mode

ABS LEVEL	RIDING MODE	CHARACTERISTIC	DEFAULT
3	ALL/URBAN/WET CONDITION	This level is designed for use in any riding conditions to provide a safe and consistent braking action. ABS in this level controls both wheels and the cornering and anti-lift-up functions are active.	It is the default level for the "TOURING" and "URBAN" riding modes.

## Tips on how to select the sensitivity level



### Attention

Excellent operation of the ABS system, for all available levels, is ensured only with the OE brake system and with OE tyres and/or with the ones recommended by Ducati. In particular, OE tyres for this motorcycle are:

- Hypermotard 950: front 120/70 ZR17 M/C (58W) Pirelli Diablo Rosso III - rear 180/55 ZR17 M/C (73W) Pirelli Diablo Rosso III
- Hypermotard 950 SP: front 120/70 ZR17 M/C (58W) Pirelli Diablo Supercorsa SP - rear 180/55 ZR17 M/C (73W) Pirelli Diablo Supercorsa SP

The use of tyres of different size and characteristics to the original tyres may alter the operating characteristics of the system thus making it unsafe. It is recommended not to install tyres of different size than the ones approved for your vehicle.

Selecting level 3, the ABS will ensure a very stable braking thanks to lift-up control, and the motorcycle will keep a good alignment during the whole braking action also in a bend, thanks to the cornering feature.

Selecting level 2, the ABS will privilege more and more the braking power, yet keeping a good lift-up control. ABS level 2 provides the cornering feature. ABS level 1 is for expert riders and privileges braking power, to the detriment of stability and lift-up control. The cornering feature is still active. Moreover, level 1 activates the function of slide control under braking (available in this level only).

The choice of the correct level mainly depends on the following parameters:

- The tyre/road grip (type of tyre, amount of tyre wear, the road/track surface, weather conditions, etc.).
- The rider's experience and sensitivity: expert riders can tackle a lift-up in trying to reduce the stopping distance to a minimum, while less expert riders are recommended to use setting 3, that will help them keeping the motorcycle more stable even in emergency braking.



## DWC indicator

The instrument panel displays DWC status as follows:

- if the DWC is active, the message "DWC" and the set intervention level number "1" to "8";
- if DWC is active, but system is in degraded operation, "DWC" indication and the number (flashing); also the DTC/DWC warning light (8, Fig 4) starts flashing;
- when in fault, the "DWC" indication and the red "Err" message; also DTC/ DWC light (8, Fig 4) turns on;
- if DWC is disabled, "DWC" "OFF" indication.

### Attention

In case of system malfunction, contact a Ducati Dealer or Authorised Service Centre.

### Note

If DTC is set to OFF, DWC is also forced to OFF.

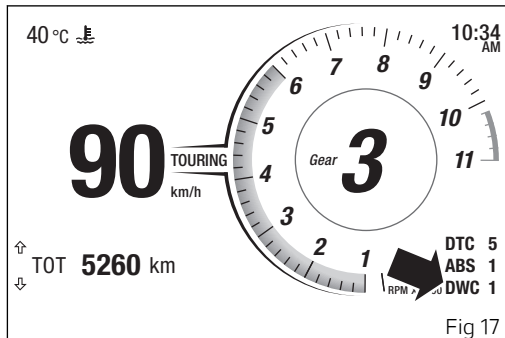

The Ducati Wheelie Control system (DWC) supervises control of wheelie movement and settings vary through eight different levels that are calibrated to offer a different prevention and reaction to wheelies. Each Riding Mode features a pre-set intervention level. Level eight indicates a setting that minimises motorcycle tendency to shift up in a wheelie and maximises reaction to the same, if it occurs. While level one is for expert riders and features a lower wheelie control in terms of prevention and less strong reaction to the same, if it occurs.



## Attention

DWC is a rider aid that can be used on both the track and the road. The system is designed to make riding easier and to enhance safety, but in no way relieves the rider of the obligation to drive responsibly and to maintain a high standard of riding in order to avoid accidents, whether caused by his own errors or those of other road users, through making emergency manoeuvres, in accordance with the prescriptions of the road traffic code.

The rider must always be aware that active safety systems have a preventive function. The active elements help the rider control the motorcycle, making it as easy and safe to ride as possible. The presence of an active safety system should not encourage the rider to ride at speeds beyond the reasonable limits, not in accordance with the road conditions, the laws of physics, good riding standards and the requirements of the road traffic code.

The following table indicates the most suitable level of DWC intervention for the various riding types as well as the default settings in the "Riding Mode" that can be selected by the rider:

DWC LEVEL	USE		DEFAULT
OFF		The DWC is disabled.	NO
1	HIGH PERFORMANCE	Road use and track use for expert riders. The system allows wheelies, but decreases the speed at which the front wheel lifts.	NO
2	PERFORMANCE	Road use and track use for expert riders. The system allows wheelies, but decreases the speed at which the front wheel lifts.	NO
3	SPORTIVE	Track use and road use for expert riders. The system reduces the motorcycle's proneness to do wheelies and intervenes in case of wheelie.	It is the default level for the "SPORT" Riding Mode
4	SPORTIVE	Track and road use for all kinds of riders. The system reduces the motorcycle's proneness to do wheelies and intervenes in case of wheelie.	NO

DWC LEVEL	USE		DEFAULT
5	SAFE & STABLE	Level for all kinds of riders. The system reduces the motorcycle's proneness to do wheelies and sensitively intervenes in case of wheelie.	It is the default level for the "TOURING" Riding Mode
6	SAFE & STABLE	Level for all kinds of riders. The system reduces the motorcycle's proneness to do wheelies and sensitively intervenes in case of wheelie.	It is the default level for the "URBAN" Riding Mode
7	HIGH SAFE & STABLE	Level for all kinds of riders. The system reduces the motorcycle's proneness to do wheelies and sensitively intervenes in case of wheelie.	NO
8	HIGH SAFE & STABLE	Level for all kinds of riders. The system reduces the motorcycle's proneness to do wheelies to a minimum level and sensitively intervenes in case of wheelie	NO

## Tips on how to select the sensitivity level

### Attention

Excellent operation of the DWC system, for all available levels, is ensured only with the OE final drive and with OE tyres and/or with the ones recommended by Ducati. The use of tyres of different size and characteristics to the original tyres may alter the operating characteristics of the system thus making it unsafe. It is recommended not to install tyres of different size than the ones approved for your vehicle.

At level 8 the DWC system reduces the motorcycle's proneness to do wheelies to a minimum level and sensitively intervenes in case of wheelie. Between level 8 and level 1 there are further intermediate levels of intervention for the DWC. Levels 1, 2 and 3 allow easier wheelies, but reduce their speed: these levels are recommended only for track use and for expert riders who can control wheelies on their own and exploit the system feature that reduces the speed at which the front wheel tends to lift.

The choice of the correct level mainly depends on the following parameters:

- The rider's experience;
- The characteristics of the path/circuit (bend exit with low or high gear engaged).

### The rider's experience

The choice of level setting depends greatly on the riders' experience and ability to control wheelies on their own. Levels 1, 2 and 3 require a great experience to ensure proper control.

### Level depends on type of track

If the track/path features bends where out speed and gear are low, a lower level will be necessary; while a track/path with faster bends will allow the use of a higher level setting.

### Tips for use on the track

We recommend to use level 8 for a couple of full laps in order to get used to the system. Then try levels 7, 6, etc., in succession until you identify the DWC sensitivity level that suits you best (always try each level for at least two laps to allow the tyres to warm up).

### Tips for use on the road

Activate the DWC, select level 8 and ride the motorcycle in your usual style; if the level of DWC sensitivity seems excessive, try levels 7, 6, etc., until you find the one that suits you best. If changes occur in the circuit characteristics, and the level setting is no longer suitable, switch to the next level up or down and proceed to determine the best setting (e.g. if with level 7 the DWC intervention seems excessive, switch to level 6; alternatively, if on level 7 you cannot perceive any DWC intervention, switch to level 8).

## Clock

The instrument panel shows the time in the following format:

- AM (for values ranging between 12:00 and 11:59), or PM (for values ranging between 12:00 and 11:59).
- hh (hours) : mm (minutes);

In case of a power off (Battery Off), upon the following Key-On, the instrument panel displays 4 dashes " - - : - - " steadily and with flashing colon and "A.M." steadily, until clock is set through the Setting Menu.

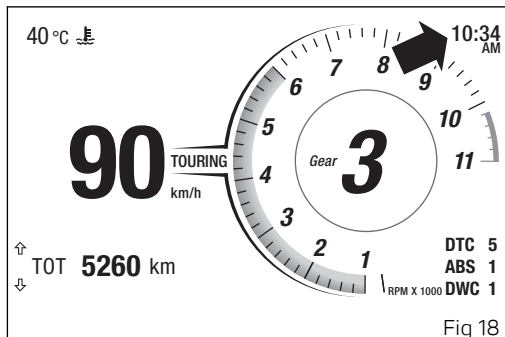

## Engine Coolant temperature

The instrument panel displays the engine coolant temperature, showing the value in the set unit of measurement (°C or °F) together with the engine temperature symbol.

The temperature display range goes from 40 °C to +120 °C (+104 °F ÷ +248 °F).

If reading is:

- $\leq$  (lower than or equal to) -40 °F (-40 °C), a string of three flashing dashes " - - - " is displayed;
- within the range -39 °C (-38 °F) to +39 °C (+102 °F), "LO" is displayed steadily;
- within the range +40 °C (+104 °F) to +120 °C (+248 °F), the value is displayed steadily;
- $\geq$  (higher than or equal to) +121 °C (+250 °F), "HI" is displayed flashing.

If the coolant temperature sensor is in fault, a string of three flashing dashes " - - - " is displayed with the set unit of measurement.

If the instrument panel is not receiving coolant temperature value, a string of steady dashes " - - - " is displayed, followed by the unit of measurement.

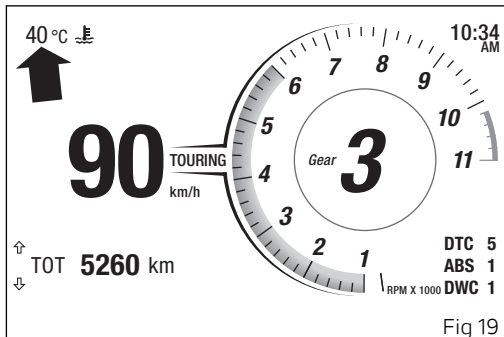

### Note

If the instrument panel does not receive any information on the unit of measurement, the default unit of measurement is displayed flashing.



## Riding mode

The Riding Mode can be selected from the instrument panel. Three preset riding modes are available: SPORT, TOURING, URBAN.

The selected and active riding mode is displayed in the central part of the display, between the speed value and the rev counter.

A dedicated page is associated with every riding mode.

The differences between the pages are the name and colour of the riding mode specified at the centre of the display and the colour of the rpm box:

- red for the SPORT Riding mode (A)
- black in DAY mode or white in NIGHT mode (see page 131) for the TOURING riding mode (B)
- grey for the URBAN riding mode (C)

Every Riding Mode contains the following parameters, set by Ducati or customised by the user through the setting menu pages:

- a specific level of intervention for the DTC traction control (1, 2, 3, 4, 5, 6, 7, 8, OFF)
- a specific ABS calibration (1, 2, 3)

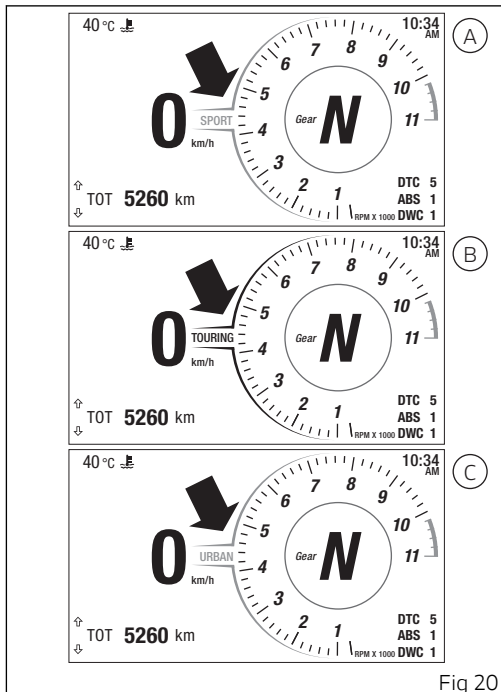

Fig 20

- a specific engine power ENGINE (HIGH, MEDIUM, LOW) that modifies APS response (Accelerator Position Sensor)
- a specific DQS quick shift (if any) gearbox calibration, if active within the BBS (UP, DOWN, UP/DOWN, OFF)
- a specific level of intervention for the wheelie control DWC (1, 2, 3, 4, 5, 6, 7, 8, OFF)

## Riding mode change function

This function allows changing vehicle riding modes in static and dynamic conditions. There are three possible riding modes: SPORT, TOURING, URBAN. To select the riding mode, press button (4) and hold it for 1 second.

The instrument panel still displays the speed indication on the right-hand side, while the left-hand side of the display lists the following:

- < Exit
- SPORT
- TOURING
- URBAN
- < Exit

When entering this function, the current riding mode is highlighted.

Use buttons (1) and (2) to scroll through the items in the list.

Select "< Exit" and press button (4) to quit the page without actually implementing the riding mode change.

When scrolling the riding modes, the parameters and their currently set values for the selected riding

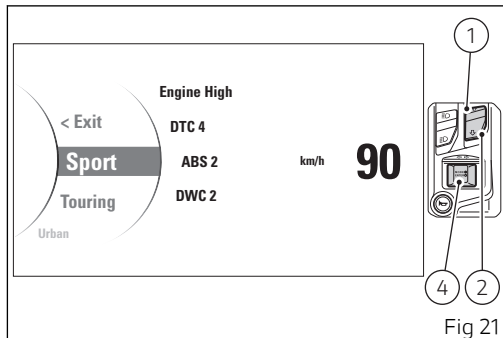

mode are shown at the centre of the display: Engine, DTC, ABS, DWC, DQS (if any).

To set the selected riding mode, press button (4).

If vehicle speed is lower than or equal to 5 Km/h (3 mph) the instrument panel checks the throttle position only:

- if throttle is "closed", the instrument panel will confirm the selected riding mode, the name of riding mode flashes for 3 seconds and instrument panel goes back to "standard page" displaying;
- if throttle is "open" the instrument panel activates the "Close throttle" (A) indication; only when throttle is "closed" the new selected riding mode is confirmed and memorised, and the instrument panel goes back to "standard page" displaying.

If vehicle speed is higher than 5 Km/h (3 mph), the instrument panel checks the throttle position and the front and rear brake pressure:

- if throttle is "closed" and brakes are released, the instrument panel confirms the selected riding mode, the name of the riding mode flashes for 3 seconds and goes back to "standard page" displaying;

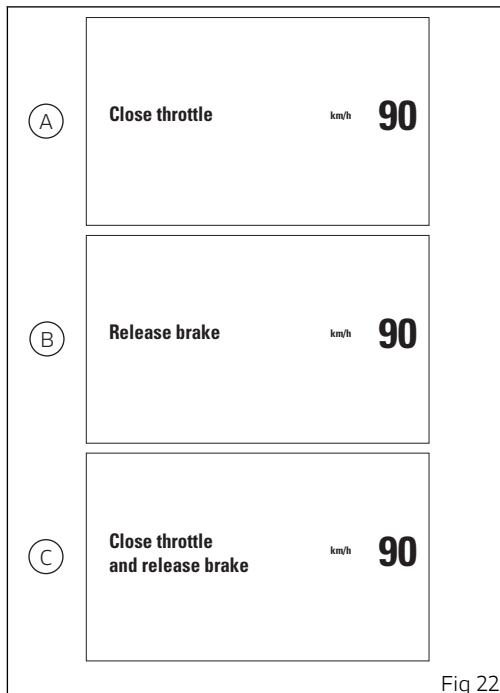

Fig 22

- if throttle is "open" the instrument panel activates the "Close throttle" (A) indication; only when throttle is "closed" the new selected riding mode is confirmed and memorised, and the instrument panel goes back to "standard page" displaying;
  - if throttle is "closed" but brakes are operated, the instrument panel activates the "Release brakes" (B) indication and only when brakes are released the new selected riding mode is confirmed and memorised, and the instrument panel goes back to standard page displaying;
  - if throttle is "open" or if brakes are operated and vehicle is moving, the instrument panel shows "Close throttle and release brakes" (C) and, only after all conditions are met (closed throttle and brakes released or vehicle stopped) the instrument panel confirms and memorises the new selected riding mode and goes back to "standard page" displaying.
- and the instrument panel will go back to displaying the page active before riding mode selection started, and no settings will be changed.



If the above-described conditions for "validating" the change of riding mode are not observed within 5 seconds from when "Close Throttle" or "Release brakes" or "Close throttle and release brakes" indications, the selection procedure will be aborted

## Function menu

From the main screen, press button (1) or (2) on LH switch to scroll through menu information.

Menu displayed functions are:

- Odometer (TOT)
- Trip meter 1 (TRIP 1)
- Average Fuel Consumption 1 (CONS.AVG 1)
- Average speed 1 (SPEED AVG 1)
- Trip time 1 (TRIP TIME 1)
- Ambient air temperature (T AIR)
- Partial fuel reserve counter (TRIP FUEL)
- Trip meter 2 (TRIP 2)
- Instantaneous fuel consumption (CONS.)
- Player management (PLAYER OFF - PLAYER ON) - only if the Bluetooth module is available and one smartphone is connected
- Call management (LAST CALLS) - only available if the Bluetooth module is available and one smartphone is connected
- Heated handgrips (HEATING GRIPS) - accessory
- Setting menu (SETTING MENU)

The UP  and DOWN  arrows - corresponding to button (1) and button (2) on LH switch - appear on the LH side of the menu indicating the possibility to

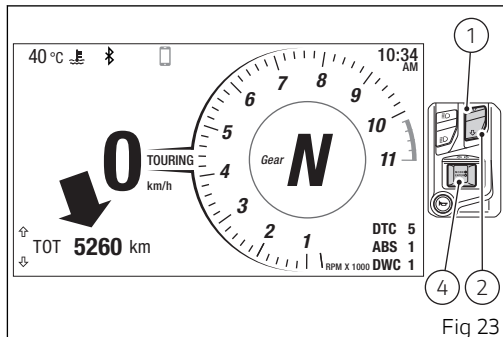

scroll through the functions. The empty circle symbol  is displayed when it is possible to interact with the displayed function by pressing button (4) on LH switch, for instance to reset trip meter 1 (TRIP 1, page 71).

## Odometer (TOT)

The odometer counts and displays the total distance covered by the motorcycle with the set unit of measurement (km or mi).

The odometer number (in km or miles) is displayed with the message TOT and the indication of the unit of measurement. When the maximum value is reached (199999 km or 199999 mi) the instrument panel will permanently display said value.

The odometer value is saved permanently and cannot be reset under any circumstances.

The reading is not lost in case of a power OFF (Battery OFF).

### Note

If a string of flashing dashes " ---- " is displayed within odometer function, please contact a Ducati Dealer or Authorised Service Centre.

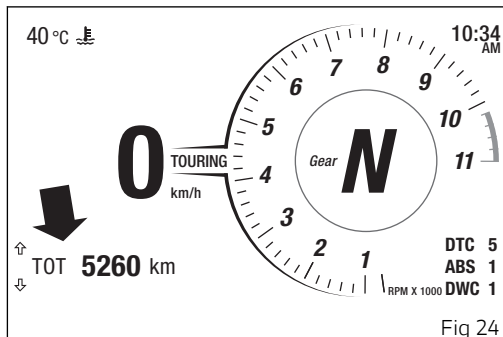

### Note

When the instrument panel is switched on, this function is displayed for 10 seconds and then instrument panel goes back to the function that was set before switch-off.

## Trip meter 1 (TRIP 1)

The trip meter 1 counts and displays the partial distance covered by the vehicle with the set unit of measurement (km or mi).

The mi or km value for TRIP 1 is displayed with the "TRIP 1" indication and unit of measurement.

When the reading exceeds the maximum value of 9999.9 mi or 9999.9 km, distance is reset and the meter automatically starts counting from 0 again.

TRIP 1 is used to calculate Average Fuel Consumption 1 (CONS. AVG 1), Average Speed 1 (SPEED AVG 1) and Trip Time 1 (TRIP 1).

Press button (4) to reset TRIP 1.

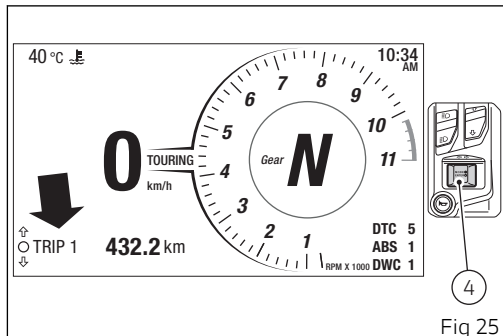

Fig 25



## Resetting of TRIP 1

While the trip meter is displayed, press button (4) and the instrument panel will show the message "RESET?".

If you press button (1) or (2), the instrument panel will display the trip meter again, without resetting the value.

While if you press button (4), the value for TRIP 1 will be reset and the instrument panel will display "0.0" followed by the set unit of measurement.

### Note

When TRIP 1 is reset, the instrument panel also resets Average Fuel Consumption 1 (CONS. AVG 1), Average Speed 1 (SPEED AVG 1) and Trip Time 1 (TRIP 1).

TRIP 1 information is automatically reset also in the following cases:

- Average Fuel Consumption 1 (CONS. AVG 1) reset
- Trip time 1 (TRIP TIME 1) reset
- due to a battery disconnection (Battery-Off);

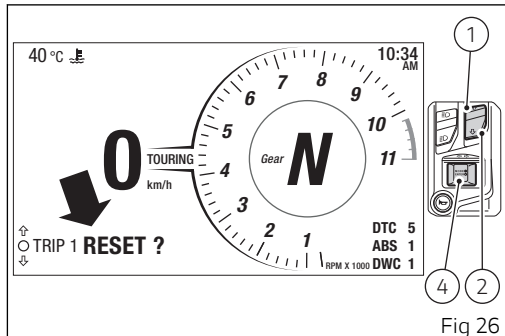

- in case of manual change of the units of measurement of the system using the Setting Menu.

## Average Fuel Consumption 1 (CONS.AVG 1)

This function shows the average fuel consumption calculated since Trip 1 (TRIP 1) was last reset. The average consumption is displayed with the indication "CONS AVG 1." and the indication of the unit of measurement (km/l or l/100 km or mpg UK or mpg US).

When TRIP 1 is reset, the value is reset and the first value available is displayed 10 seconds after the reset. During the first 10 seconds, when the value is not yet available, the display will show a string of dashes "- - -" as average fuel consumption.

The active calculation phase occurs when the engine is running, even when the vehicle is stopped. Moments when the vehicle is not moving and the engine is off are not considered.

Press button (4) to reset CONS.AVG 1.

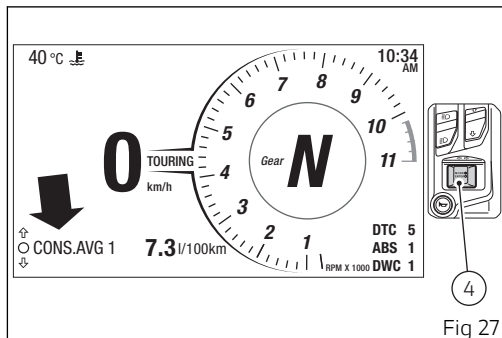

Fig 27

## Resetting of CONS.AVG 1

If button (4) is pressed when average fuel consumption is displayed, the instrument panel will activate the warning "RESET ?" in place of the value and unit of measurement.

If you press button (1) or (2), the instrument panel will display the average fuel consumption again, without resetting the value.

While if you press button (4), average fuel consumption is reset, and during the first 10 seconds when the value is not available, the display shows the dashes "- - - ." together with the set unit of measurement.

### Note

When CONS.AVG 1 is reset, the instrument panel also resets Trip 1 (TRIP 1), Average Speed 1 (SPEED AVG 1) and Trip Time 1 (TRIP 1).

CONS. AVG 1 information is automatically reset also in the following cases:

- when Trip meter 1 (TRIP 1) is reset;
- when Trip time (TRIP TIME 1) is reset;
- due to a battery disconnection (Battery-Off);

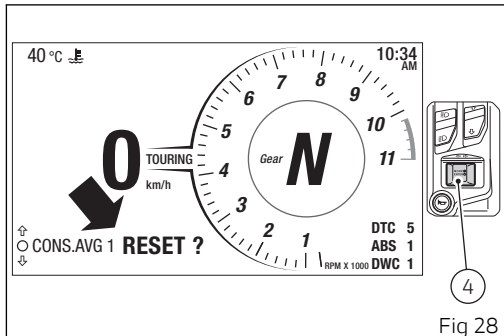

- in case of manual change of the units of measurement of the system using the Setting Menu.

## Average speed 1 (SPEED AVG 1)

This function shows the average speed calculated since Trip 1 (TRIP 1) was last reset.

The average speed is displayed with the indication "SPEED AVG. 1" and the indication of the unit of measurement (km/h or mph).

The average speed value displayed is calculated by adding 5%, as to be consistent with motorcycle speed indication.

When TRIP 1 is reset, the value is reset and the first value available is displayed 10 seconds after the reset. During the first 10 seconds, when the value is not yet available, the display will show a string of dashes "- - -" as average speed.

The active calculation phase occurs when the engine is running, even when the vehicle is stopped. Moments when the vehicle is not moving and the engine is off are not considered.

Press button (4) to reset SPEED AVG 1.

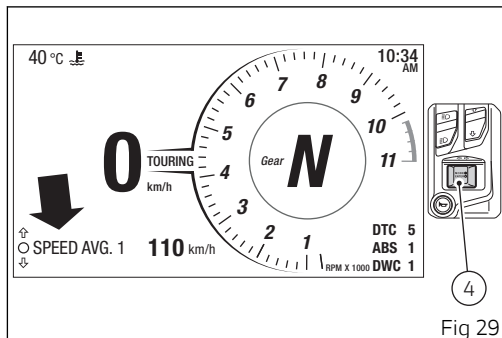

Fig 29

## Resetting SPEED AVG. 1

If button (4) is pressed when average speed is displayed, the instrument panel will activate the warning "RESET ?" in place of the value and unit of measurement.

If you press button (1) or (2), the instrument panel will display the average speed again, without resetting the value.

While if you press button (4), average speed is reset, and during the first 10 seconds when the value is not available, the display shows the dashes "- - -" together with the set unit of measurement.

### Note

When SPEED AVG. 1 is reset, the instrument panel also resets the trip meter 1 (TRIP 1), Average fuel consumption 1 (CONS. AVG 1) and Trip time 1 (TRIP TIME 1).

The SPEED. AVG. 1 counter is automatically reset also in the following cases:

- when Trip meter 1 (TRIP 1) is reset;
- when Trip time (TRIP 1 TIME) is reset;
- when Average Fuel Consumption (CONS. AVG 1) is reset;

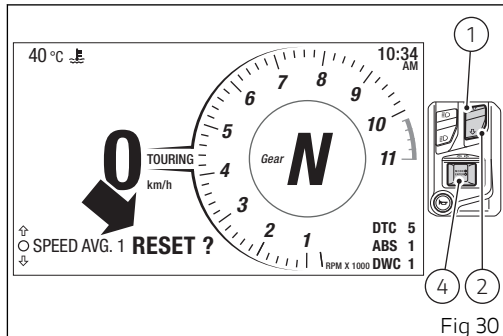

- due to a battery disconnection (Battery-Off);
- in case of manual change of the units of measurement of the system using the Setting Menu.

## Trip time 1 (TRIP TIME 1)

The instrument panel shows the trip time calculated since Trip 1 (TRIP 1) was last reset.

Value is displayed as hhh:mm followed by "TRIP TIME 1" indication.

The active time counting phase occurs when the engine is running, even when the vehicle is stopped. The time count is automatically stopped when the vehicle is not moving and the engine is off and restarts when the counting active phase starts again.

When the reading exceeds 511:00 (511 hours and 00 minutes), the meter is reset and automatically starts counting from 0 again.

Press button (4) to reset TRIP TIME 1.

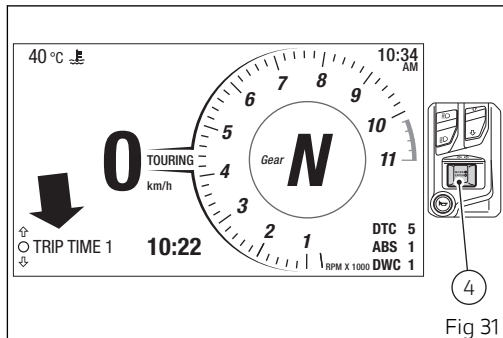

Fig 31

## Resetting of TRIP TIME 1

If button (4) is pressed when trip time is displayed, the instrument panel will activate the warning "RESET ?" in place of the value.

If you press button (1) or (2), the instrument panel will display the trip time again, without resetting the value.

While if you press button (4), value for trip time will be reset and the instrument panel will display TRIP TIME 1 at "0:00".

### Note

When TRIP TIME 1 is reset, the instrument panel also resets Trip 1 (TRIP 1), Average Speed 1 (SPEED AVG 1) and Average Fuel Consumption 1 (CONS. AVG 1).

The CONS. AVG 1 counter is automatically reset also in the following cases:

- when Trip meter 1 (TRIP 1) is reset;
- when Average Fuel Consumption (CONS. AVG 1) is reset;
- due to a battery disconnection (Battery-Off);

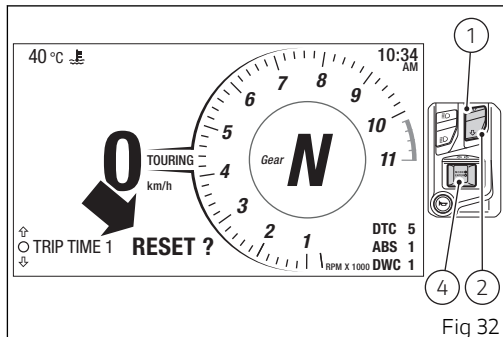

- in case of manual change of the units of measurement of the system using the Setting Menu.

## Ambient air temperature (T AIR)

The instrument panel displays the ambient temperature followed by "T AIR" and the set unit of measurement (°C or °F).

The temperature value is displayed when ranging from -39 °C to +124 °C (or -38 °F ÷ +255 °F). For temperature values lower than -39 °C (-38 °F) or higher than +124 °C (+255 °F) a string of three steady dashes " - - - " is displayed followed by the unit of measurement.

If the instrument panel is not receiving air temperature value, a string of three steady dashes " - - - " is displayed, followed by the unit of measurement.

### Note

When the motorcycle is stopped, the engine heat could influence the displayed temperature.

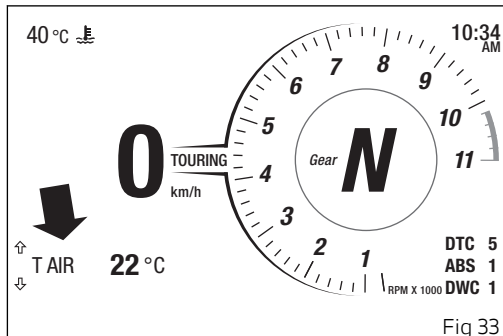

Fig 33



## Partial fuel reserve counter (TRIP FUEL)

To select this function in the function menu, scroll the functions available using buttons (1) and (2) to display "TRIP FUEL".

The fuel trip meter counts and displays the distance covered by the motorcycle on reserve (i.e. since the low fuel light, (5, Fig 4) turns on) with the set unit of measurement (km or mi).

When the low fuel light (5 Fig 4) turns on, the display automatically shows the TRIP FUEL function, regardless of the currently displayed function; then, it is possible to toggle through the other function menu functions.

Trip fuel reading remains stored even after Key-Off until the motorcycle is refuelled. Count is interrupted automatically as soon as fuel is topped up to above minimum level.

The number of mi or km is displayed with the TRIP FUEL indication and unit of measurement.

When the reading exceeds the maximum value of 9999.9 km or 9999.9 mi, distance travelled is reset and the meter automatically starts counting from 0 again.

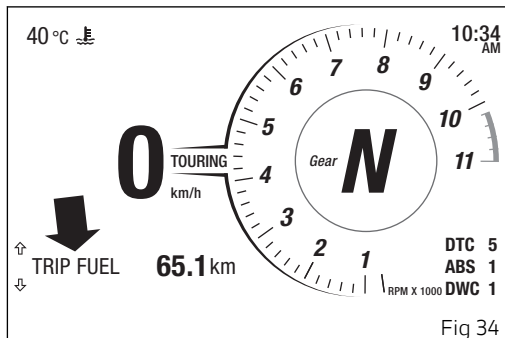

When the TRIP FUEL function is not active, the corresponding value will not be displayed in the Function Menu.

## Trip meter 2 (TRIP 2)

The trip meter 2 counts and displays the partial distance covered by the vehicle with the set unit of measurement (km or mi).

The mi or km value for TRIP 2 is displayed with the "TRIP 2" indication and unit of measurement.

When the reading exceeds the maximum value of 9999.9 mi or 9999.9 km, distance is reset and the meter automatically starts counting from 0 again.

Press button (4) to reset TRIP 2.

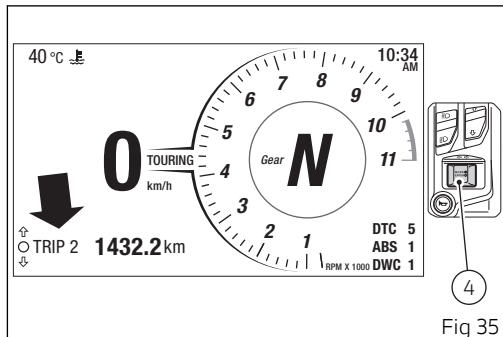

Fig 35

## Resetting of TRIP 2

While the trip meter is displayed, press button (4) and the instrument panel will show the message "RESET?".

If you press button (1) or (2), the instrument panel will display the trip meter again, without resetting the value.

While if you press button (4), the value for TRIP 2 will be reset and the instrument panel will display "0.0" followed by the set unit of measurement.

TRIP 2 information is automatically reset also in the following cases:

- due to a battery disconnection (Battery-Off);
- in case of manual change of the units of measurement of the system using the Setting Menu.

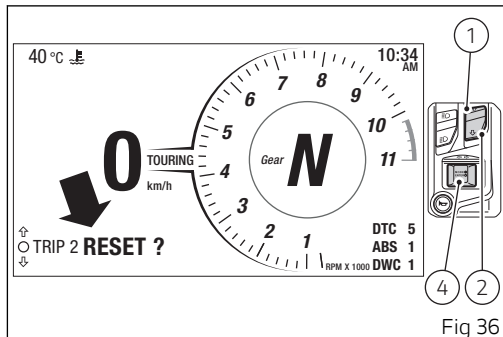

## Instantaneous fuel consumption (CONS.)

The instrument panel calculates and shows vehicle instant fuel consumption.

Instant fuel consumption is displayed with the indication "CONS." and the indication of the unit of measurement (km/L or L/100 km or mpg UK or mpg US).

The active calculation phase only occurs when the engine is running and the vehicle is moving (times when the vehicle is not moving when speed is equal to 0 and/or when the engine is off are not considered).

During the phase when no calculation is performed, three steady dashes " - - . - " are displayed as a value of instantaneous consumption.

It is possible to change the units of measurement for fuel consumption (both average and instantaneous together) through the Setting menu.

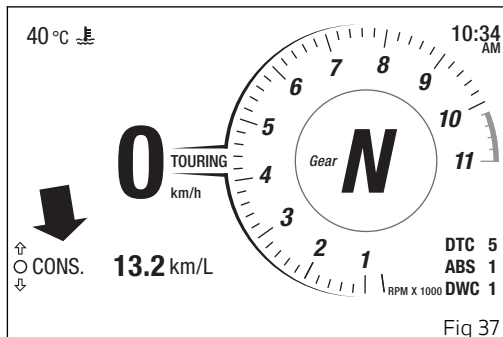

## Music player management (PLAYER) - accessory

This function allows activating, deactivating and managing the music player. It is available only if the Bluetooth control unit is installed and a smartphone is connected. The function can be set to "OFF" or "ON".

### Important

If the smartphone connected to the instrument panel via Bluetooth is disconnected or turned off, the "Music player management (PLAYER)" function will not be listed in the functions of the menu. It appears again only when the smartphone is connected again to the instrument panel via Bluetooth.

### Note

If the rider helmet/intercom is connected in addition to the smartphone, the tracks will be listened through the helmet headphones.

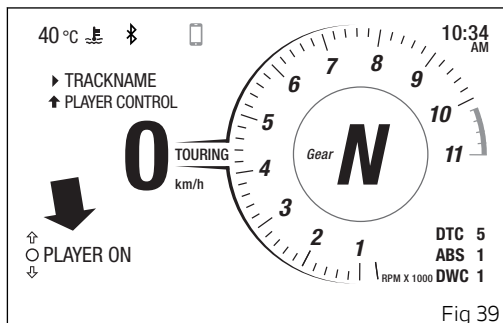
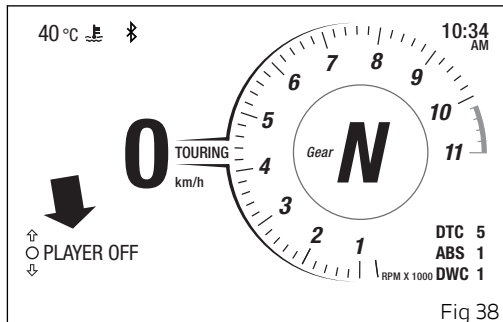

Music player control activation (from OFF to ON).

If the music player control is set to "OFF", press button (4) to activate it.

With the music player control active, the display shows the title of the track currently being played on the connected smartphone (A), together with the available controls (B), and the "EXIT" indication preceded by the black arrow facing downwards (C).

The full name of the track is displayed once, scrolling the characters from right to left, then only the first characters are displayed. If the title of the track is not available, "NOT AVAILABLE" will be displayed.

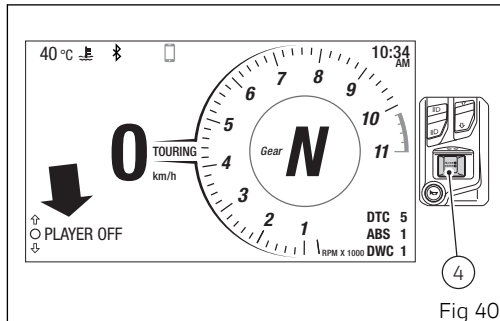

Fig 40

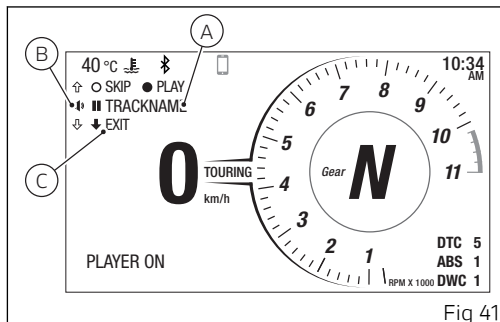

Fig 41

## Music player controls

When the control is active, button (1), button (2) and button (4) are used by the instrument panel only for the music player controls. In particular:

- Play / Pause: press button (4) for 2 seconds.
- "SKIP" to next track: briefly press button (4).
- Increase volume "+": briefly press button (1). The symbol "+" disappears while the button is being pressed to indicate that the operation has been carried out.
- Decrease volume "-": briefly press button (2). The symbol "-" disappears while the button is being pressed to indicate that the operation has been carried out.
- "EXIT" from the music player control: press button (2) for 2 seconds.

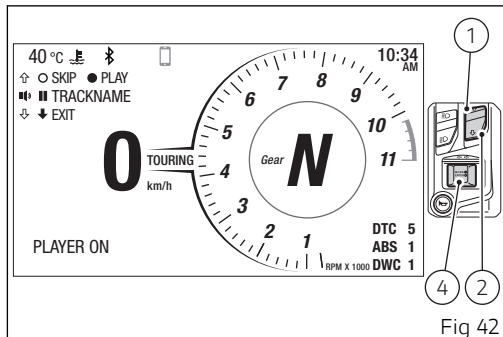

Fig 42

## Play / Pause

When the track is paused (A), the display shows, to the left of the track, the symbol " || " and the black circle " ● " above, followed by the indication "PLAY", to indicate that if button (4) is pressed for 2 seconds the player will be started.

When the track is being played (B), the display shows, to the left of the track, the symbol " ▶ " and the black circle " ● " above, followed by the "PAUSE" indication, to indicate that if button (4) is pressed for 2 seconds the track will be paused.

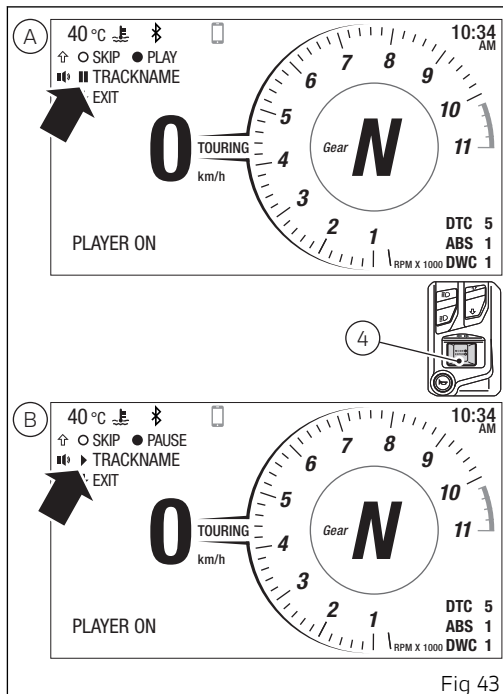

Fig 43



## Exiting the active music player control (ON):

To exit the music player control (A) and keep it active, for example with the track being played, press button (2) for 2 seconds.

Then button (1), button (2) and button (4) go back to their "standard" functions for the management/control of the instrument panel and are no longer used for the music player functions.

With the player on, even if you change function (e.g. TRIP 1), track title remains displayed.

After its activation, the function "Music player management (PLAYER)" is shown within the menu as "PLAYER ON" and a black arrow up is displayed underneath the track title, followed by "PLAYER CONTROL" (B).

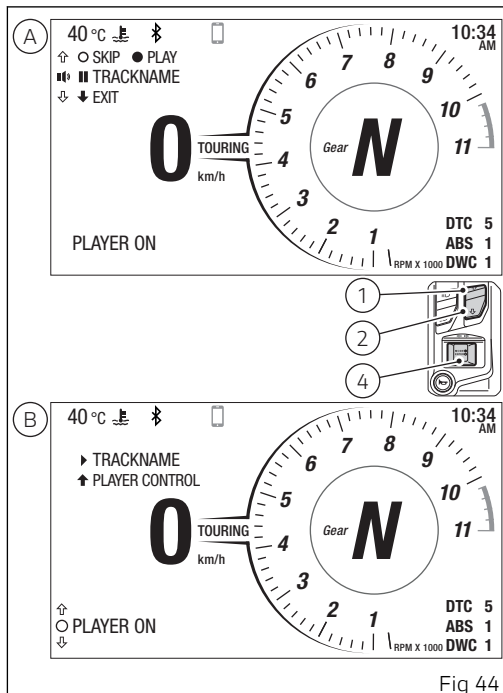

Fig 44

## Reactivating the music player control (ON):

If the music player was activated and you exited the control to move to other functions, to reactivate the controls of the music player select the "Music player management (PLAYER)" (A) function in the menu and press button (1) for 2 seconds.

It is hence possible to access again to the music player control and button (1), button (2) and button (4) are used again by the instrument panel only for the music player controls (B).

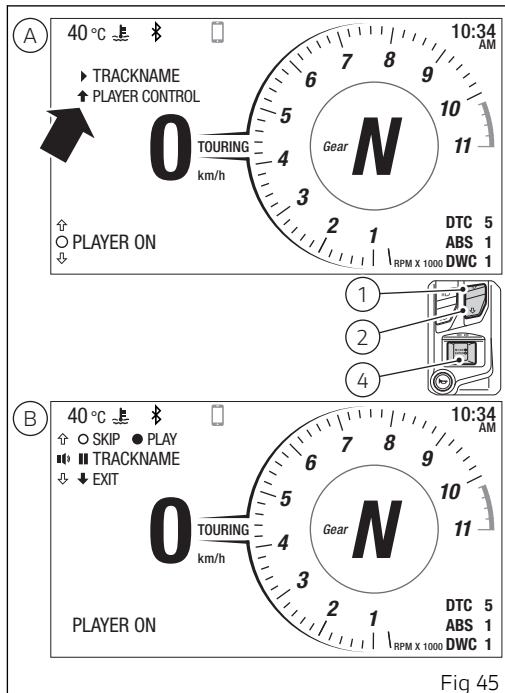

Fig 45

Music player control deactivation (from ON to OFF):

To set the music player control to "OFF" stopping also the track being played, select the PLAYER function from the menu.

The function will be indicated with the message "ON" (A), at this point press button (4).

The music player control is then set to "OFF" (B).

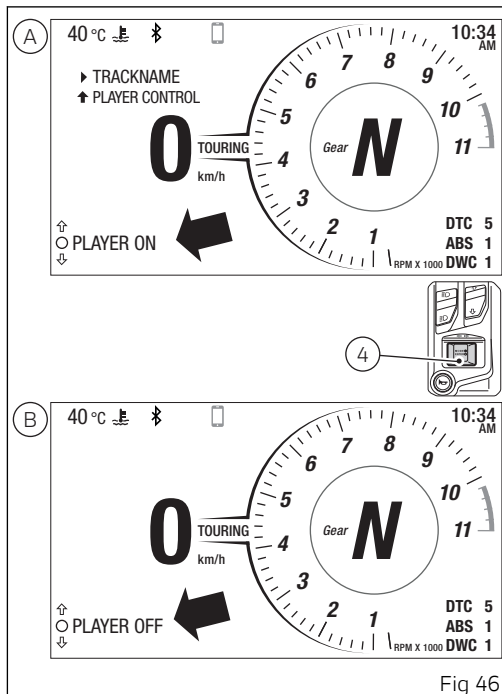

## Call management (LAST CALLS) - accessory

This function shows the list of the last missed, outgoing or incoming calls and is available only if the Bluetooth control unit is installed and a smartphone is connected.

To display the list of calls, press button (4). When entering this function, the display shows message "WAIT.." for a few seconds, then shows the name or phone number from the last call (Fig 48).

The instrument panel receives the call list information directly from the smartphone currently connected via Bluetooth. Only the last 7 made, received or missed calls are displayed.

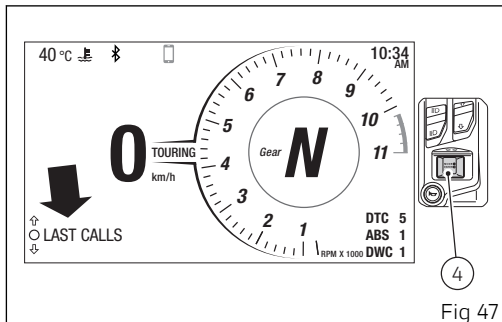

Fig 47

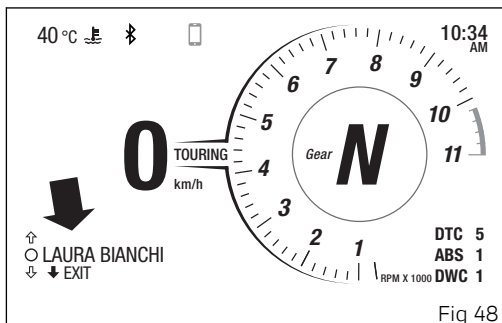

Fig 48

Use buttons (1) and (2) to scroll through the calls in the list. To make a call to the number/name selected from the list, press button (4). For more information refer to the chapter "Infotainment - accessory" on page 168.

If the list of calls is empty, "EMPTY" will be displayed (Fig 50). In this case it is only possible to exit the function.

To exit the function and go back to the previous screen, press button (2) for 2 seconds.

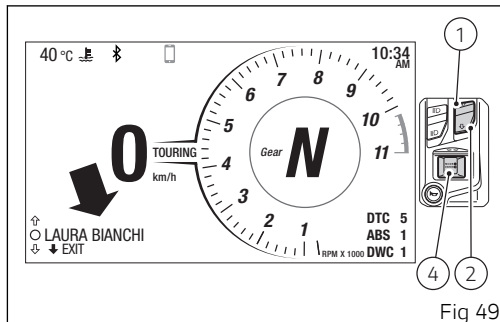

Fig 49

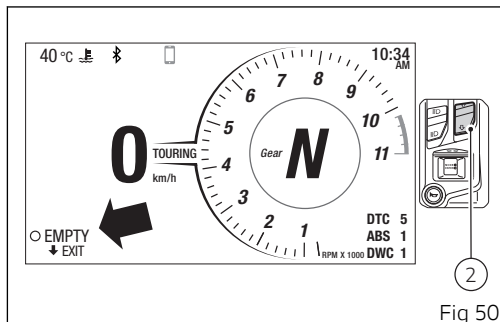

Fig 50

## Heated handgrips (HEATING GRIPS) - accessory

This function is available only if the heated handgrips have been installed, allowing their activation, deactivation and adjustment.

Press button (1) and (2) to select the HEATING GRIPS function inside the function menu (Fig 51).

Pressing button (4) you view heated handgrip current setting ("OFF", "LOW", "MEDIUM", "HIGH") and the black arrow down followed by "EXIT" (Fig 52).

Now use button (1) and button (2) to scroll the levels, starting from the current one ("OFF", "LOW", "MEDIUM" and "HIGH").

To select the new level for the heated handgrips and quit the settings, briefly press button (4) when display shows the required level.

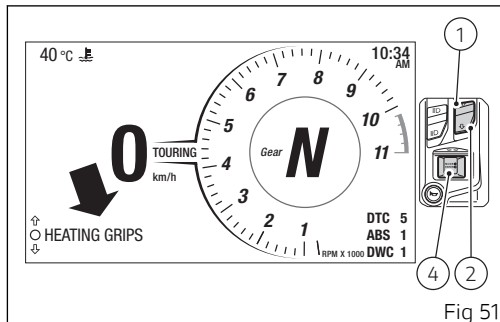

Fig 51

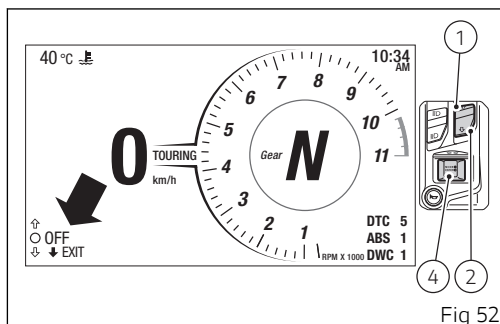

Fig 52

When a level other than “OFF” is selected, the heated handgrips symbol is displayed in the main page (Fig 53). The turning on of this symbol indicates that the heated handgrips are ready to be heated.

The actual turning on (heating) of the heated handgrips occurs only with engine started, when a certain number of engine rpm have been reached and maintained. This is to avoid affecting the battery charge level.

The actual switch-on (Fig 54) is indicated by the colour of the icon corresponding to the current heating level:

- icon on green background = “LOW” level
- icon on amber yellow background = “MEDIUM” level
- icon on red background = “HIGH” level

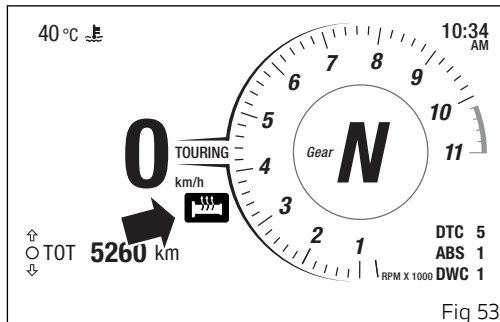

Fig 53

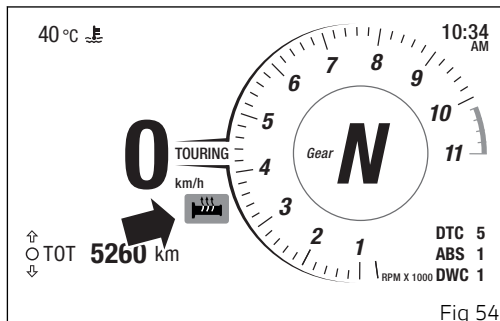

Fig 54

## Setting menu (SETTING MENU)



This menu allows enabling, disabling and setting some motorcycle functions.

For safety reasons, you can enter this Menu only when the actual vehicle speed is lower than or equal to 5 km/h (3 mph).

If you are inside the setting menu and the actual vehicle speed exceeds 5 km/h (3 mph) the instrument panel automatically exits from the setting menu and displays the main screen.

To gain access to the setting menu, use button (1) or (2) to select "SETTING MENU" and press button (4).

### Note

The empty circle symbol  is only displayed when the actual vehicle speed is lower than or equal to 5 km/h (3 mph): if the actual vehicle speed is lower than or equal to 5 km/h (3 mph) and suddenly it goes above 5 km/h (3 mph), the empty circle symbol  turns off, and will come on again when vehicle speed is again lower than or equal to 5 km/h (3 mph).

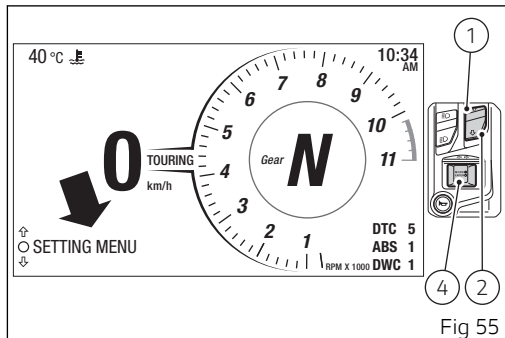



Once entered in the setting menu the display changes the display mode.

The functions available inside the setting menu are:

- Riding Mode
- Pin Code
- Lap
- Backlight
- Date and Clock
- Units
- Service
- Tire Calibration
- DRL Control – active only if the DRL lights are present
- Bluetooth – active only if the Bluetooth module is fitted
- Turn Indicators
- Info

### Important

For safety reasons, it is recommended to use this menu with the motorcycle at a standstill.

Press button (1) or (2) to view the above functions of the setting menu one by one: in particular, use

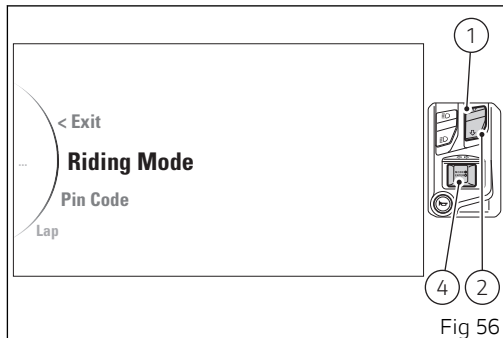

Fig 56

button (2) to view the following item and button (1) to view the previous item.

After displaying the required function, press button (4) to open the corresponding menu page.

If function is not available or temporarily disabled, the menu page can not be opened.

To quit the setting menu you shall select "< Exit" and press button (4).

## Setting menu - riding mode (Riding Mode)

All settings of every riding mode can be customised.

Enter the setting menu (SETTING MENU).

Select "Riding Mode" by pressing button (1) or (2).

Once function is displayed, press button (4).

When entering the function, the display shows available riding modes on the left side and current riding mode on the right side (Fig 58).

The following indications will be displayed in this page:

- < Back
- Sport
- Touring
- Urban
- All Default (visible only if one or more parameters of one or more Riding Modes are different from the "default" ones)
- < Back

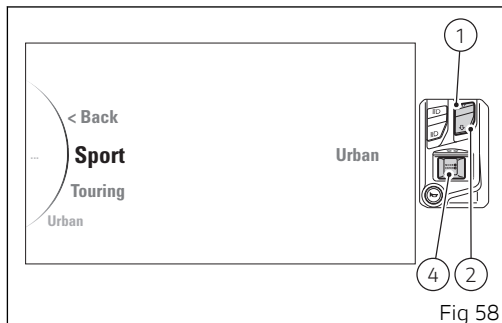
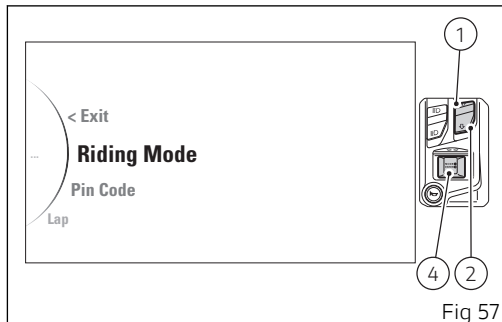

You can use buttons (1), (2) and (4) to do the following:

- use buttons (1) and (2) to select the riding mode to customise, then press button (4) to access the customisation page for the selected riding mode;
- use buttons (1) and (2) to select "< Back" press button (4) to go back to previous page;
- use buttons (1) and (2) to select "All Default", press button (4) to reset to default values for all four Riding Modes.

The parameters linked to a riding mode that can be customised are Engine, DTC, ABS, DWC, DQS (if any) and Default (to reset riding mode to default factory values) (Fig 59).

The following indications will be displayed in this page:

- < Back
- Engine
- DTC
- ABS
- DWC
- DQS (if present)

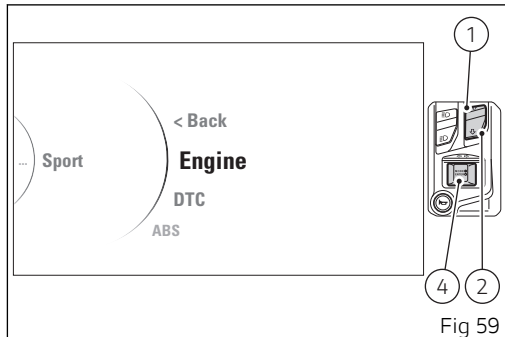

- Default (visible only if one or more parameters are different from the "default" ones)
- < Back

Every time you press button (1) or (2) the instrument panel scrolls all the parameters for the selected Riding Mode. Once the parameter is highlighted, press button (4) to enter its setting page.

Any parameter change made is saved and remains in the memory also after a battery-off.

The parameters set by Ducati for each individual riding mode can be reset with the "Default" function and by pressing button (4).

Highlight "< Back" and press button (4) to exit the sub-menu and go back to previous page.



### **Attention**

Changes should only be made to the parameters by people who are experts in motorcycle set-up. If the parameters are changed accidentally, use the "Default" function to restore factory settings.



### **Note**

If the DTC is disabled (set to OFF), the DWC parameter can not be changed and is forced to level OFF.

## Setting menu - riding mode- setting the engine (Engine)

This function customises engine power associated with each riding mode.

To open this function:

- enter the setting menu (SETTING MENU);
- press button (1) or button (2) to select "Riding Mode" (A) and press button (4);
- then select the riding mode to be modified ("Sport", "Touring", "Urban") (B) and press button (4);
- then select the "Engine" indication (C) and press button (4).

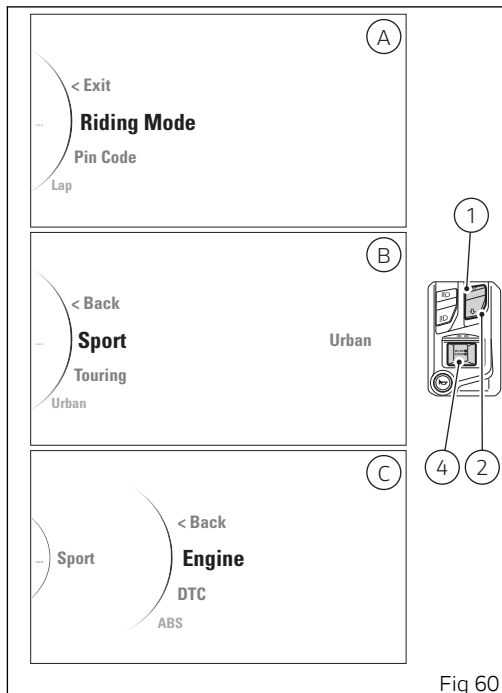

Fig 60

When entering the function, the display shows available customised settings - "High", "Medium", "Low" - on the left side and current setting on the right side.

The following indications will be displayed in this page:

- < Back
- High
- Medium
- Low
- < Back

At the centre of the screen is also the bike profile with the service area highlighted, and a chart containing reference information.

With buttons (1) and (2) select the new desired engine power.

For each level, the corresponding value in the table is highlighted.

Once the desired level is selected, press button (4) to confirm the selection.

To exit the menu and go back to previous page use buttons (1) and (2) to select the "< Back" indication and press button (4).

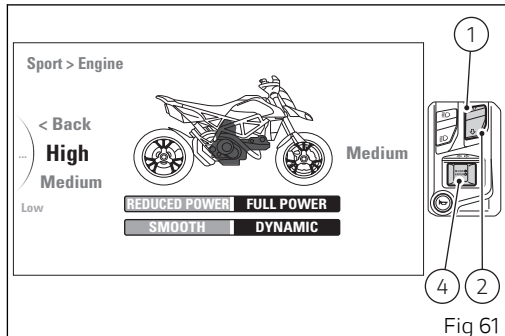

## Setting menu - riding mode- setting the DTC (DTC)

This function allows customising or disabling DTC (Ducati Traction Control) intervention level, for each single riding mode.

To open this function:

- enter the setting menu (SETTING MENU);
- press button (1) or button (2) to select "Riding Mode" (A) and press button (4);
- then select the riding mode to be modified ("Sport", "Touring", "Urban") (B) and press button (4);
- then select the "DTC" indication (C) and press button (4).

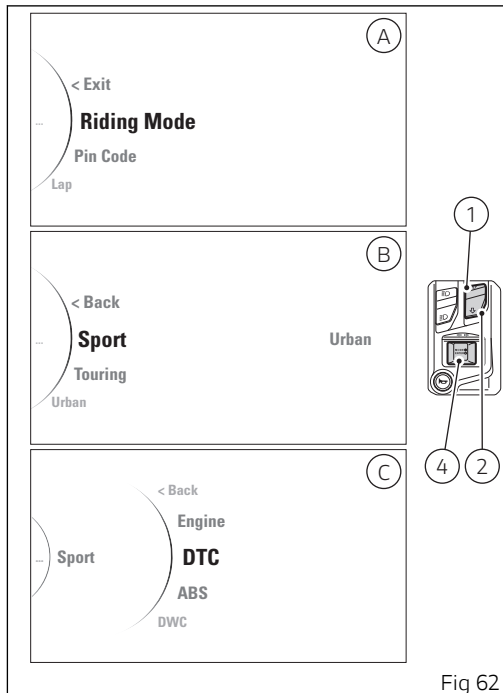

Fig 62

When entering the function, the display shows available customised level settings - "8" to "1" and "Off" - on the left side and current setting on the right side.

The following indications will be displayed in this page:

- < Back
- 8
- 7
- 6
- 5
- 4
- 3
- 2
- 1
- Off
- < Back

At the centre of the screen is also the bike profile with the service area highlighted, and a chart containing reference information.

Use buttons (1) and (2) to select the desired level. For each level, the corresponding value in the table is highlighted.

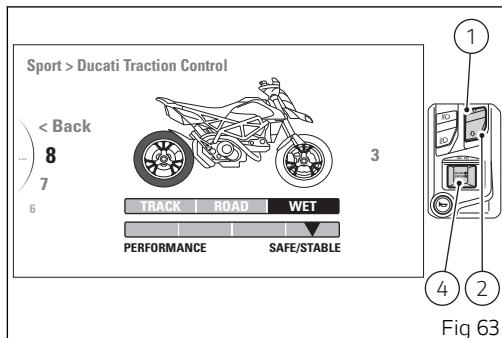

Fig 63

Once the desired level is selected, press button (4) to confirm the selection.

To exit the menu and go back to previous page use buttons (1) and (2) to select the "< Back" indication and press button (4).



 **Note**

If DTC is disabled, also DWC will be automatically disabled: in this case it will not be possible to enter the setting menu for the DWC. When DTC shall be re-enabled, previously saved DWC level will be set, and rider can then customise DWC setting.

## Setting menu - riding mode- setting the ABS (ABS)

This function allows customising ABS intervention level, for each single riding mode.

To open this function:

- enter the setting menu (SETTING MENU);
- press button (1) or button (2) to select "Riding Mode" (A) and press button (4);
- then select the riding mode to be modified ("Sport", "Touring", "Urban") (B) and press button (4);
- then select the "ABS" indication (C) and press button (4).

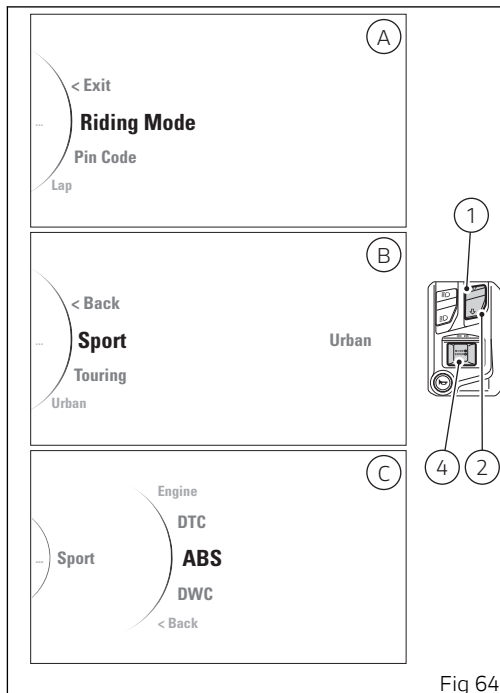

Fig 64

When entering the function, the display shows available customised level settings - "3" to "1" - on the left side and current setting on the right side. The following indications will be displayed in this page:

- < Back
- 3
- 2
- 1
- < Back

At the centre of the screen is also the bike profile with the service area highlighted, and a chart containing reference information.

Use buttons (1) and (2) to select the desired level. For each level, the corresponding value in the table is highlighted.

Once the desired level is selected, press button (4) to confirm the selection.

To exit the menu and go back to previous page use buttons (1) and (2) to select the "< Back" indication and press button (4).

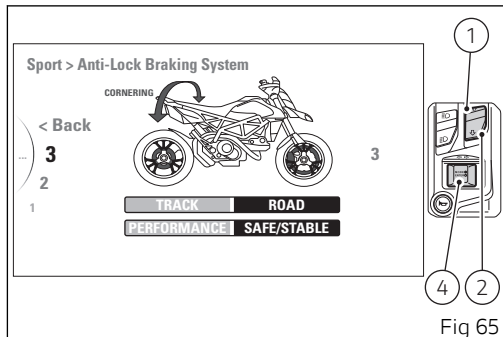

## Setting menu - riding mode- setting the DWC (DWC)

This function allows customising or DWC (Ducati Wheelie Control) intervention level, for each single riding mode.

To open this function:

- enter the setting menu (SETTING MENU);
- press button (1) or button (2) to select "Riding Mode" (A) and press button (4);
- then select the riding mode to be modified ("Sport", "Touring", "Urban") (B) and press button (4);
- then select the "DWC" indication (C) and press button (4).

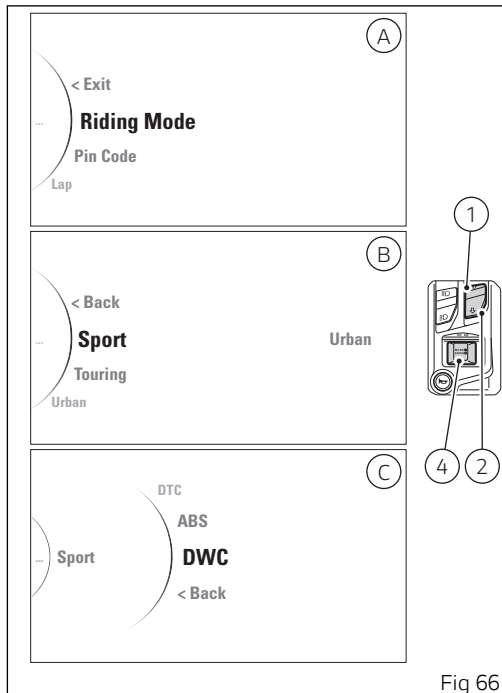

Fig 66

When entering the function, the display shows available customised level settings - "8" to "1" and "Off" - on the left side and current setting on the right side.

The following indications will be displayed in this page:

- < Back
- 8
- 7
- 6
- 5
- 4
- 3
- 2
- 1
- Off
- < Back

At the centre of the screen is also the bike profile with the service area highlighted, and a chart containing reference information.

Use buttons (1) and (2) to select the desired level. For each level, the corresponding value in the table is highlighted.

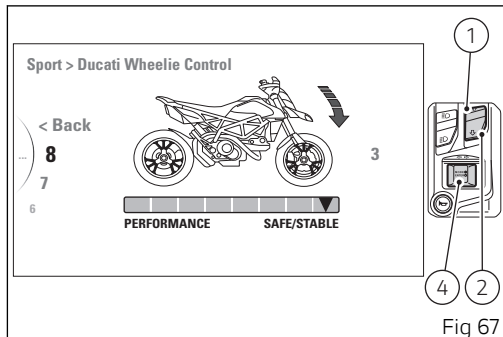

Once the desired level is selected, press button (4) to confirm the selection.

To exit the menu and go back to previous page use buttons (1) and (2) to select the "< Back" indication and press button (4).

 **Note**

If DTC is disabled, also DWC will be automatically disabled: in this case it will not be possible to enter the setting menu for the DWC. When DTC shall be re-enabled, previously saved DWC level will be set, and rider can then customise DWC setting.

## Setting menu - riding mode - setting the DQS - accessory (DQS)

This function disables or enables the DQS in UP/DOWN mode for each single riding mode, and is available only if the DQS is actually installed to the vehicle.

To open this function:

- enter the setting menu (SETTING MENU);
- press button (1) or button (2) to select "Riding Mode" (A) and press button (4);
- then select the riding mode to be modified ("Sport", "Touring", "Urban") (B) and press button (4);
- then select the "DQS" indication (C) and press button (4).

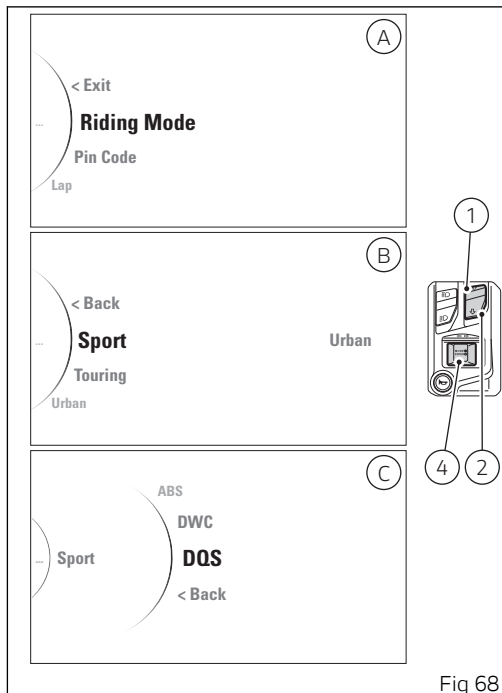

Fig 68

When entering the function, the display shows available customised level settings - "Up/Down" and "Off" - on the left side and current setting on the right side.

The following indications will be displayed in this page:

- < Back
- Up/Down
- Off
- < Back

At the centre of the screen, the service area is also highlighted.

Use buttons (1) and (2) to select the desired level. For each level, the corresponding value in the table is highlighted.

Once the desired level is selected, press button (4) to confirm the selection.

To exit the menu and go back to previous page use buttons (1) and (2) to select the "< Back" indication and press button (4).

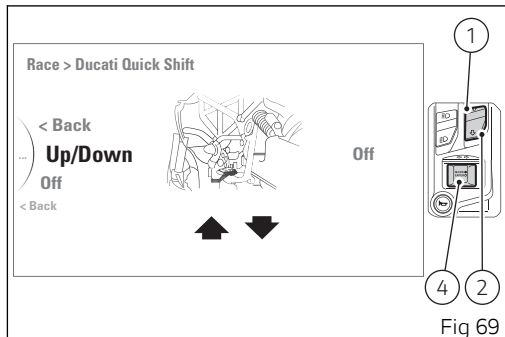



## Setting menu - riding mode- restore values (Default)

This function restores all parameters for a single riding mode and is only available if one or more parameters have been previously modified, compared to factory settings.

To open this function:

- enter the setting menu (SETTING MENU);
- press button (1) or button (2) to select "Riding Mode" (A) and press button (4);
- then select the riding mode to be modified ("Sport", "Touring", "Urban") (B) and press button (4);
- then select "Default" (C).

Press button (4) when "Default" is selected; the instrument panel sets all parameters for the selected riding mode to factory settings. The display shows "< Back" and the "Default" item is no longer in the list.

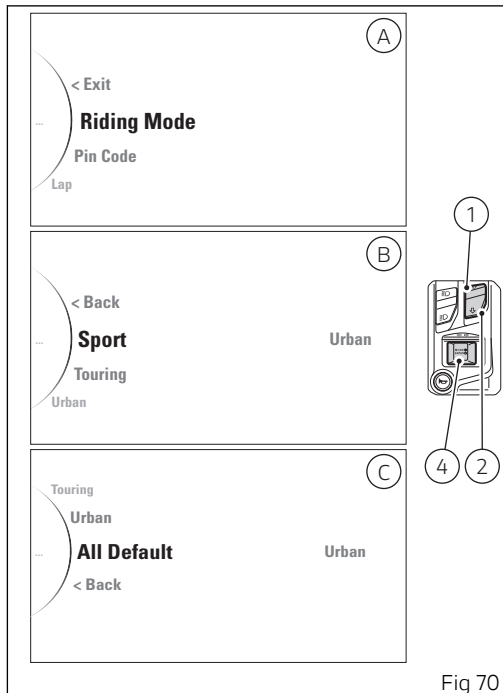

Fig 70

## Setting menu - riding mode - restore all values for all riding modes (All Default)

This function restores all parameters for all riding modes and is only available if one or more parameters have been previously modified, in one or more riding modes, compared to factory settings. To open this function:

- enter the setting menu (SETTING MENU);
- press button (1) or button (2) to select "Riding Mode" (Fig 71) and press button (4);
- select "All Default" (Fig 72).

Press button (4) when "All Default" is selected; the instrument panel sets all parameters for all riding modes to factory settings. The display shows "< Back" and the "All Default" item is no longer in the list.

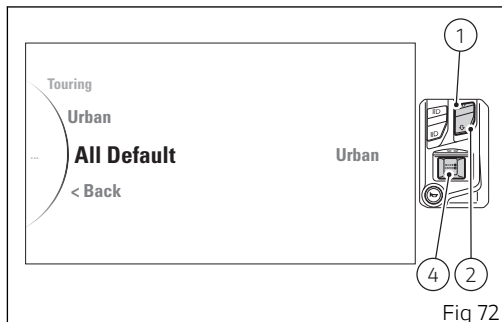
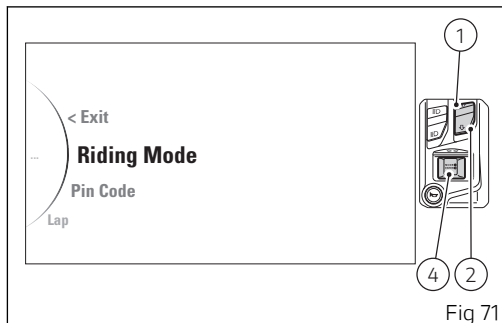

## Setting menu - pin code activation (Pin Code)

This function allows the user to activate or modify the Pin Code.

The Pin Code is initially not present in the motorcycle, it must be activated by the user by entering his/her 4-digit PIN in the instrument panel, otherwise the motorcycle cannot be started temporarily in the case of a malfunction.

To change the Pin Code refer to the chapter "Setting menu - Pin code (Pin Code)".

In order to temporarily start the motorcycle in case of malfunction, please refer to the procedure called "Restoring motorcycle operation via the Pin Code".

### Attention

The motorcycle owner must activate (store) the PIN code; if there is already a stored PIN, contact an Authorised Ducati Dealer to have the function "reset". To perform this procedure, the Authorised Ducati Dealer may ask you to demonstrate that you are the owner of the motorcycle.

Enter the setting menu (SETTING MENU).

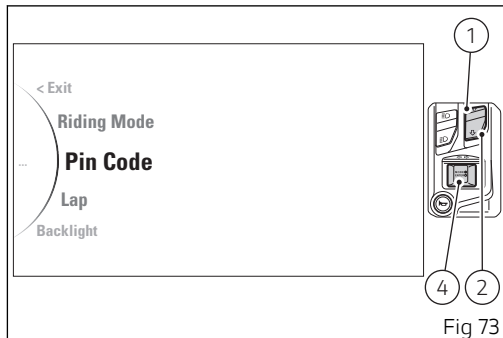

"Select Pin Code option", by pressing button (1) or (2). Once function is displayed, press button (4).

The following indications will be displayed in this page:

- < Back
- New Pin

Select "New Pin" (A) using button (1) and button (2) and press button (4) to validate and enter the new Pin Code.

To exit the menu and go back to previous page highlight the "< Back" indication and press button (4).

### Note

If "Modify Pin" appears when accessing this function, this means that there is already a stored Pin Code and therefore the function is already active.

Entering the Pin Code (B):

After accessing the new Pin Code entering function, the instrument panel displays "New Pin" with spaces allowing to enter the four digits of the code: "0" and "- - -".

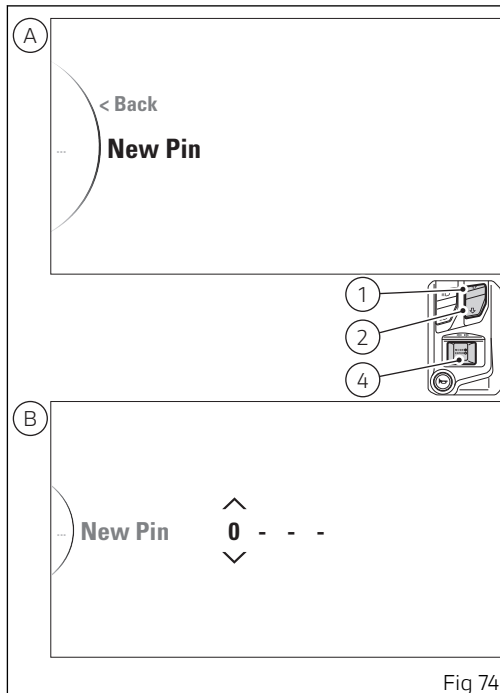

Fig 74

The two arrows above and below the digit indicate that it is possible to change the value using button (1) and button (2).

Entering the code:

- 1) Each time you press the button (1) the displayed number increases by one (+1) up to "9" and then starts back from "0";
- 2) Each time you press the button (2) the displayed number decreases by one (-1) up to "0" and then starts back from "9";
- 3) Press button (4) to confirm the number and move on to the following digit.
- 4) Repeat the operations under steps 1) - 3) until you confirm all the 4 digits of the Pin Code.

Once the last digit has been entered, when pressing button (4) the instrument panel activates the following indications:

- < Back
- Memory (orange)

To exit the menu and go back to previous page without saving the set code, highlight the "< Back" indication and press button (4).

To memorise the entered code, highlight the "Memory" indication (orange) and press button (4) (Fig 75).

Then, the instrument panel will activate the "Memorised" indication (green) for 2 seconds.

At the end of the 2 seconds, the instrument panel goes back to the previous screen with the indication "Modify Pin" (instead of "New Pin"): in fact, after memorising the first Pin Code, the page of the menu where to enter the "New Pin" is no longer available and is replaced by the page to modify the Pin Code.

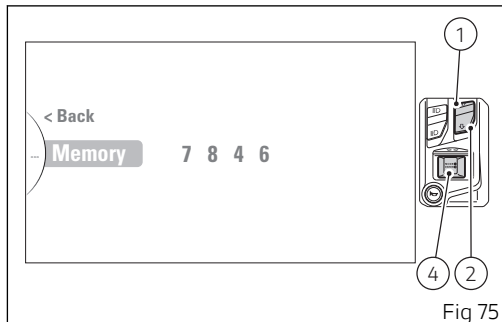

Fig 75

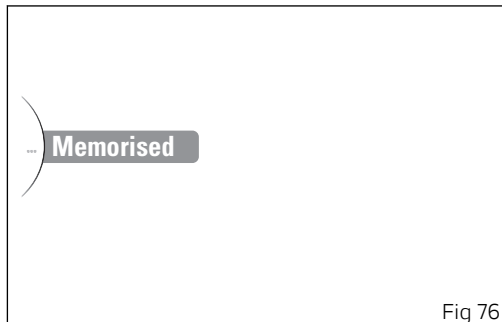

Fig 76



## Note

The page for entering the PIN CODE is active and available again only in case the Pin Code function is reset (but this is only possible through the DUCATI diagnosis instrument).

## Setting menu - pin code modification (Pin Code)

This function allows the user to activate or modify the Pin Code.

To activate the Pin Code refer to the chapter “Setting menu - Pin code activation (Pin Code)”.

In order to temporarily start the motorcycle in case of malfunction, please refer to the procedure called “Restoring motorcycle operation via the Pin Code”.

### Note

To change the PIN CODE, you must know the already stored PIN.

Enter the setting menu (SETTING MENU).  
“Select Pin Code option”, by pressing button (1) or (2).  
Once function is displayed, press button (4).

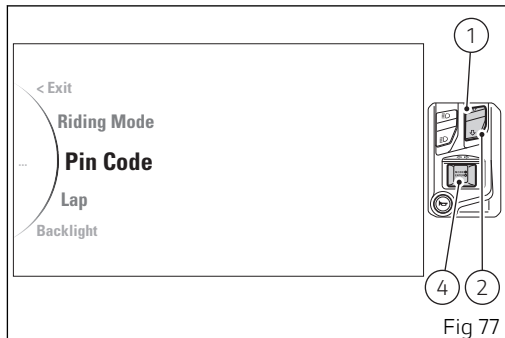



As you enter this function, the instrument panel displays the following indications:

- < Back
- Modify Pin

Select "Modify Pin" (A) using button (1) and button (2) and press button (4) to validate and modify the Pin Code.

To exit the menu and go back to previous page highlight the "< Back" indication and press button (4).

### Note

If "New Pin" appears when accessing this function, it means that the Pin Code has never been activated and it is necessary to do it.

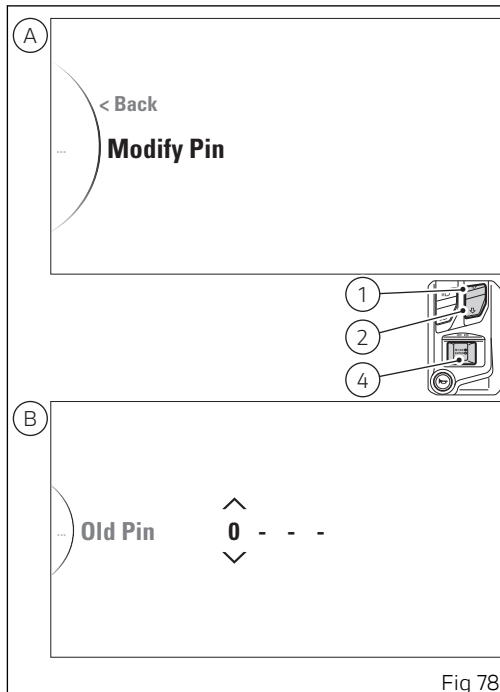

Fig 78

## Entering the old Pin Code:

After accessing the Pin Code change function (Modify Pin), the instrument panel displays "Old Pin" with spaces allowing to enter the four digits with the previously set Pin code: "0" and "- - -". The two arrows above and below the digit indicate that it is possible to change the value using button (1) and button (2).

Entering the code:

- 1) Each time you press the button (1) the displayed number increases by one (+1) up to "9" and then starts back from "0";
- 2) Each time you press the button (2) the displayed number decreases by one (-1) up to "0" and then starts back from "9";
- 3) Press button (4) to confirm the number and move on to the following digit.
- 4) Repeat the operations under steps 1) - 3) until you confirm all the 4 digits of the Pin Code.

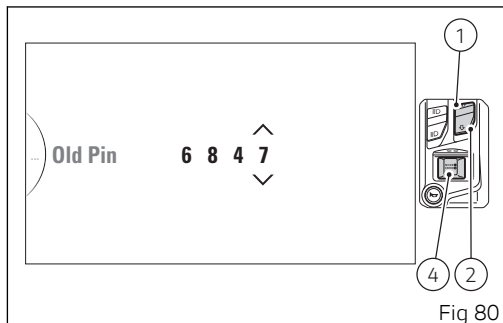
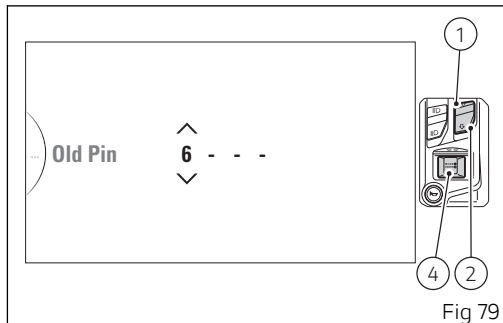

When you press button (4) to confirm the fourth and last digit, the instrument panel responds as follows:

- if the pin code is not correct, the instrument panel displays "Wrong" (Fig 81) highlighted in red for 2 seconds and then goes back to previous screen, to allow you to try again;
- if the pin code is correct, the instrument panel shows "Correct" highlighted in green for 2 seconds, and then displays the page for entering the new Pin Code

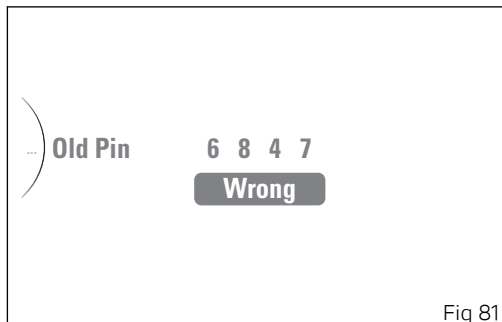

Fig 81

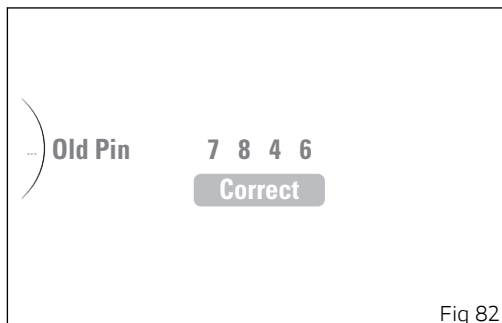

Fig 82

## Entering the new Pin Code:

After accessing the new Pin Code entering function, the instrument panel displays "New Pin" with spaces allowing to enter the four digits of the code: "0" and "- - -".

The two arrows above and below the digit indicate that it is possible to change the value using button (1) and button (2).

Entering the code:

- 1) Each time you press the button (1) the displayed number increases by one (+1) up to "9" and then starts back from "0";
- 2) Each time you press the button (2) the displayed number decreases by one (-1) up to "0" and then starts back from "9";
- 3) Press button (4) to confirm the number and move on to the following digit.
- 4) Repeat the operations under steps 1) - 3) until you confirm all the 4 digits of the Pin Code.

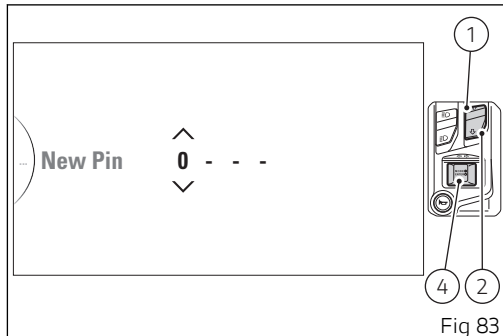

Once the last digit has been entered, when pressing button (4) the instrument panel activates the following indications:

- < Back
- Memory (orange)

To exit the menu and go back to previous page without saving the set code, highlight the "< Back" indication and press button (4).

To memorise the entered code, highlight the "Memory" indication (orange) and press button (4) (Fig 84).

Then, the instrument panel will activate the "Memorised" indication (green) for 2 seconds.

At the end of the 2 seconds, the instrument panel goes back to the previous screen.



### Note

You can change your PIN CODE an unlimited number of times.

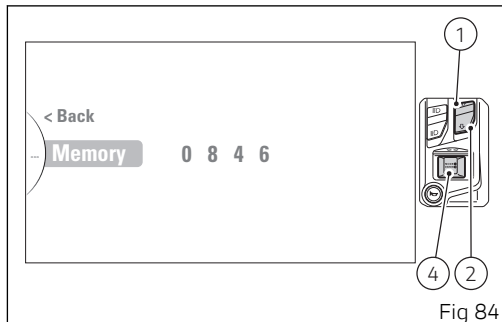

Fig 84

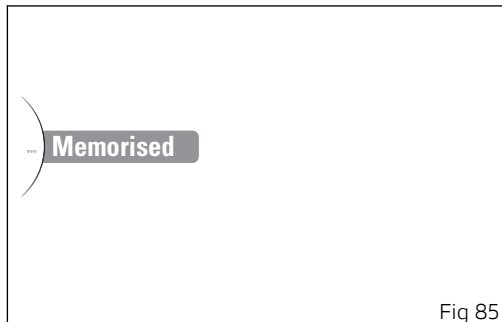

Fig 85

## Setting menu - lap time (Lap)

This function allows the rider to enable or disable the lap timer and view or delete the stored lap information.

It is possible to record a maximum of 30 laps. For each lap, system stores top speed and maximum rpm as read during the lap.

Enter the setting menu (SETTING MENU).

Select "Lap", by pressing button (1) or (2). Once function is displayed, press button (4).

As you enter this function, the instrument panel displays the following indications:

- < Back
- On (\*)
- Off (\*\*)
- Lap Data
- Erase All (\*\*\*)
- < Back

(\*) This indication is visible only if the lap function is "disabled" (Off)

(\*\*) This indication is visible only if the lap function is "enabled" (On)

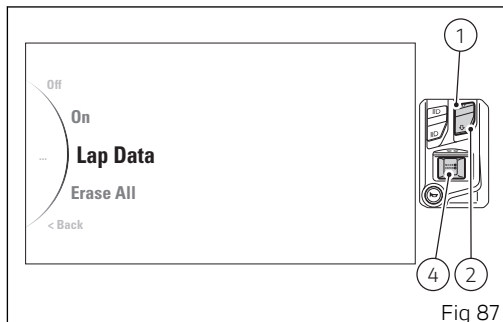
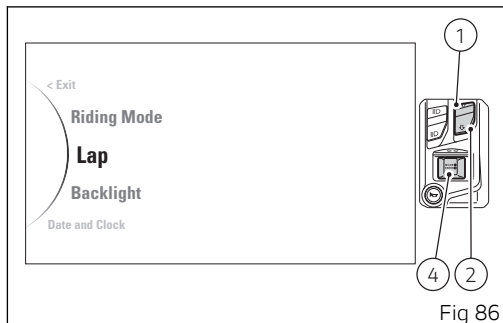

(\*\*\*) This indication is visible only if one or more saved laps are present

Use buttons (1) and (2) to select the indication and press button (4) to activate the relevant function.

- If the indication is "On" the instrument panel activates the Lap Function; once it is activated, it is possible to record the lap time;
- If the indication is "Off" the instrument panel disabled the Lap function;
- If the indication is "Lap Data", the instrument panel displays the stored laps;
- If the indication is "Erase All", the instrument panel erases all stored laps.



### Note

In case of Key-Off or of an interruption of the power supply from the battery (Battery Off), when power is restored at the next Key-On, the LAP function will always be set by default to "Off".

To exit the menu and go back to previous page highlight the "< Back" indication and press button (4).

## Displaying the stored laps

The laps previously stored can be displayed. The information displayed is lap time, maximum rpm and top speed.

To view the laps, enter (the SETTING MENU, use buttons (1) and (2) to select "Lap" and press button (4).

Then use buttons (1) and (2) to select "Lap Data" and press button (4).

If there are no memorised laps, when accessing this page the instrument panel will show "< Back" and "No Lap".

To exit the menu and go back to previous page highlight the "< Back" indication and press button (4).

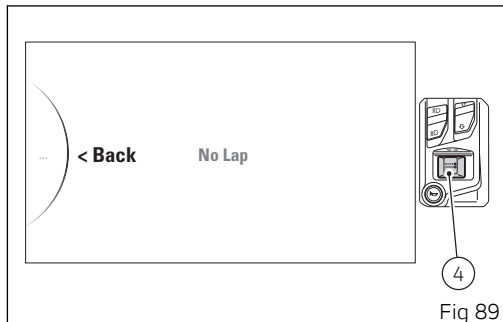



If there are memorised laps, when accessing this page the instrument panel will show the following information:

- < Back
- Lap 01
- .....
- Lap 30
- < Back

With buttons (1) or (2) it is possible to select one information. The displayed LAPs are only the recorded ones. For each memorised LAP, the display shows also:

- the word "Time" followed by the recorded LAP time (minutes – seconds – hundredths of second);
- "Speed Max" indication followed by the top speed recorded during the lap;
- "Rpm Max" indication followed by the engine rpm value reached in the recorded lap.

It is possible to record maximum of 30 LAPs.

To exit the menu and go back to previous page highlight the "< Back" indication and press button (4).

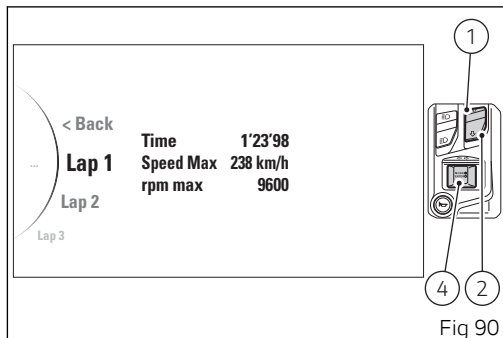

#### Note

The MAX stored speed is reached during lap (increased by 5%).



#### Note

If top speed over the lap exceeded 299 Km/h (186 mph), this function shows the actual speed reached (e.g.: 316 Km/h).

## Erasing stored laps

The memorised laps can be erased with the “Erase All” function.

To erase the laps, enter (the SETTING MENU, use buttons (1) and (2) to select “Lap” and press button (4).

When entering this function, the instrument panel will not activate any erasing option if no lap is stored. While if there are stored laps, the option “Erase All” is displayed when entering this function, allowing the rider to erase the lap data.

Use buttons (1) and (2) to select “Erase All” and press button (4).

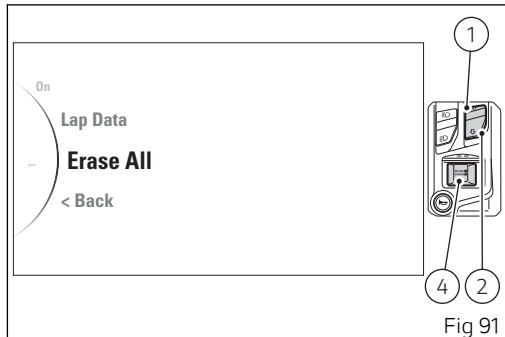

After confirming the "Erase All" function, the instrument panel shows:

- "Wait..." for 1 second;
- and then "Erase OK" for 1 second to inform about the result of the deletion process.

Deletion is one single command that erases all stored laps.

### Note

If the memory erasing procedure is started when the function is active, the instrument panel will stop the function.

To exit the menu and go back to previous page highlight the "< Back" indication and press button (4).

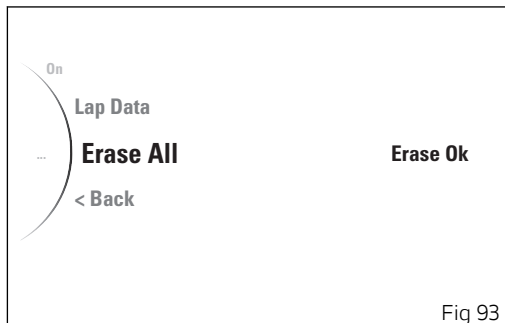
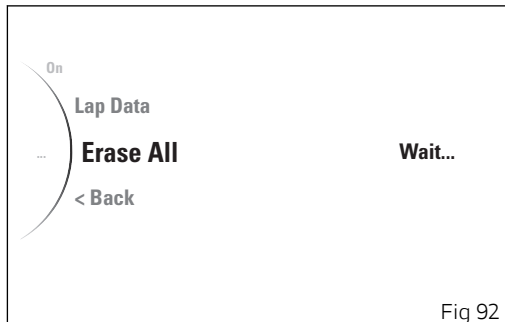

## Setting menu - setting the backlighting (Backlight)

This function allows the rider to set the way display colours are viewed according to NIGHT and DAY modes.

Enter the setting menu (SETTING MENU).  
Select "Backlight", by pressing button (1) or (2). Once function is displayed, press button (4).

When entering the function, the display shows available modes on the left side and current mode on the right side (Fig 95).

The following indications will be displayed in this page:

- < Back
- Day
- Night
- Auto
- < Back

With buttons (1) and (2) it is possible to select the desired display backlight.  
Once the desired backlight is highlighted, press confirm button (4) to memorise the new selection.

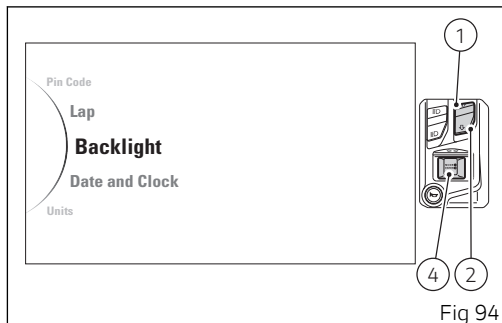

Fig 94

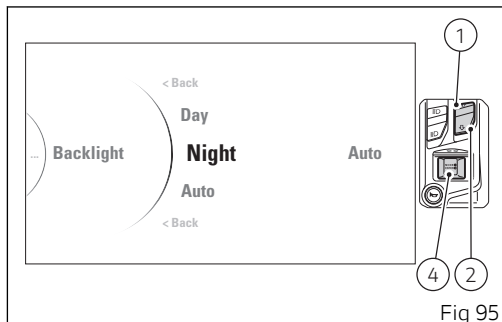

Fig 95

To exit the menu and go back to previous page highlight the "< Back" indication and press button (4).

Select "Day" (day mode) to permanently set display white background for improved readability, recommended in conditions of strong ambient light.

Select "Night" (night mode) to permanently set display black background for dimmed visibility, recommended in case of poor ambient light and/or at night.

Select "Auto" (automatic mode) to automatically adjust background colour according to ambient light (detected by a sensor). If exterior light is very bright, the display will switch to white background. If exterior light is poor, the display will switch to black background.



### **Note**

In case of battery off, when the voltage is restored and upon next Key-On, back lighting will always be set on "AUTO" mode.

## Setting menu - setting the date and time (Date and Clock)

This function allows setting date and time.

Enter the setting menu (SETTING MENU).  
Select "Date and Clock" option, by pressing button (1) or (2). Once function is displayed, press button (4).

The following indications will be displayed on this page (Fig 97):

- < Back
- Date
- Clock
- < Back

With buttons (1) and (2) it is possible to select the parameter to be modified.

Select "Date", at the centre of the display is currently set date in the format "YYYY / MM / DD" (year / month / day); press button (4) to set the date.

Select "Clock", at the centre of the display is currently set time in the format "AM/PM HH : MM" (AM or PM, hours : minutes); press button (4) to set the time.

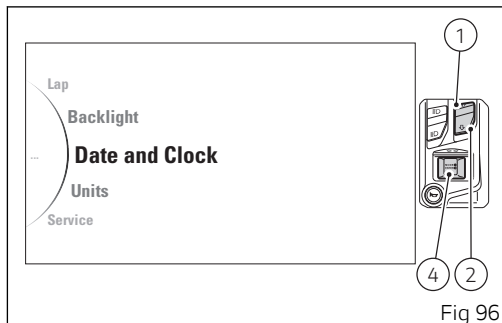

Fig 96

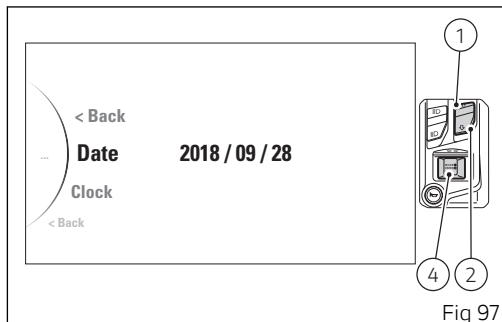

Fig 97

To exit the menu and go back to previous page highlight the "< Back" indication and press button (4).

 **Note**

If the date has never been set or has been reset, the display shows a string of dashes in place of the year, month and day (" - - - - / - - / - -").

 **Note**

If the time has never been set or has been reset, the display shows time as "AM - - : - -".

## Date setting (Date)

Select "Date" (A) and press button (4), the instrument panel will show "Set..." on the right side, and at the centre the flashing year with two arrows above and below the number (B), thereby indicating the possibility to modify the figure by means of button (1) and button (2):

- press button (1) to increase year value by 1 ("2000", "2001", ..... "2099", "2000");
- press button (2) to decrease year value by 1 ("2099", "2098", ..... "2000", "2099");
- once you reach the year to be set, press button (4) to confirm. The arrows will then move to the month value to allow setting it.

When the two arrows are displayed above and below the flashing month indication, they give the possibility to set it:

- press button (1) to increase the month by 1 ("01", "02", ..... "12", "01");
- press button (2) to decrease the month by 1 ("12", "11", ..... "01", "12");

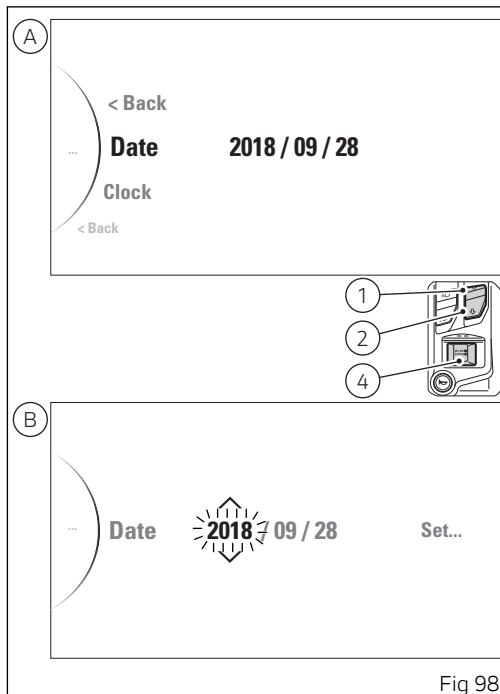

Fig 98



- once you reach the month to be set, press button (4) to confirm. The arrows will then move to the day value to allow setting it.



## Important

Every time the battery is disconnected, the date is reset and must be set again.

When the two arrows are displayed above and below the flashing day indication, they give the possibility to set it:

- press button (1) to increase the day by 1 ("01", "02", ... "31", "01");
- press button (2) to decrease the day by 1 ("31", "30", ... "01", "31");
- once you reach the day to be set, press button (4) to confirm.

After pressing button (4) to confirm the day, the instrument panel saves the set date and activates the indication "< Back".

If date is not correct, the instrument panel will display "Wrong" for 3 seconds and then it will automatically go back to setting the year without storing any new date.

To exit the menu highlight the "< Back" indication and press button (4).

## Time setting (Clock)

Select "Clock" (A) and press button (4), the instrument panel will show "Set..." on the right side, and at the centre the flashing time with "AM" or "PM" and with two arrows above and below (B), thereby indicating the possibility to modify the figure by means of button (1) and button (2). Once you set the desired value, press button (4) to confirm: the arrows move to the hour value to allow setting it.

When the two arrows are displayed above and below the flashing hour indication, they give the possibility to set it:

- press button (1) to increase hour value by 1 ("01", "02", ... "12", "01");
- press button (2) to decrease hour value by 1 ("12", "11", ..... "01", "12");
- once you reach the value to be set, press button (4) to confirm. The arrows will then move to the minute value to allow setting it.

When the two arrows are displayed above and below the flashing minute indication, they give the possibility to set it:

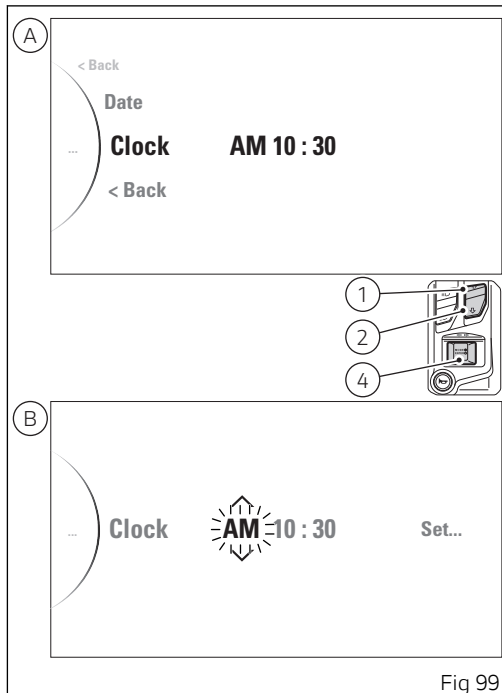

Fig 99

- press button (1) to increase minutes by 1 ("00", "01", ..... "59", "00");
- press button (2) to decrease minutes by 1 ("59", "58", ..... "00", "59");
- once you reach the value to be set, press button (4) to confirm.

After pressing button (4) to confirm the minutes, the instrument panel saves the set time and activates the indication "< Back".

To exit the menu highlight the "< Back" indication and press button (4).



### **Note**

Every time the battery is disconnected, the clock is reset and must be set again by the user.

## Setting menu - unit of measurement setting (Units)

This function allows changing the units of measurement of the displayed values.

Enter the setting menu (SETTING MENU).  
Select "Units" option, by pressing button (1) or (2).  
Once function is displayed, press button (4).

As you enter this function (Fig 101), the instrument panel displays the following indications:

- < Back
- Speed
- Temperature
- Consumption
- All Default
- < Back

The "All Default" indication is visible only if one or more parameters have been modified.

Measurements for which it is possible to change the unit are the following:

- Speed;
- Temperature;
- Fuel consumption.

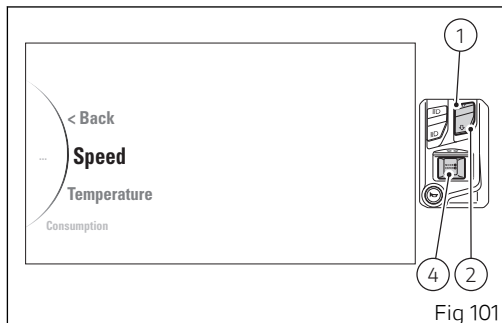
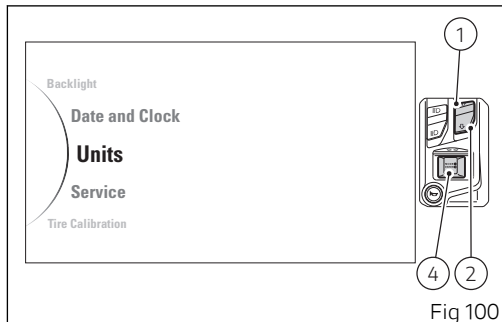

With buttons (1) and (2) it is possible to select the measurement of which you wish to change the unit:

- select "Speed" and press button (4) to customise the speed unit of measurement;
- select "Temperature" and press button (4) to customise temperature unit of measurement;
- select "Fuel consumption" and press button (4) to customise fuel consumption unit of measurement;
- select "All Default" and press button (4) to restore all values of the units of measurements of all displayed quantities.

To exit the menu and go back to previous page highlight the "< Back" indication and press button (4).

## Setting the unit of measurement for speed (Speed)

This function allows to change the units of measurement of speed and hence even the ones of distance travelled.

This page (Fig 103) shows currently set units of measurement on the right side and the following options on the left side:

- < Back
- km/h
- mph
- Default
- < Back

"Default" indication is visible only if the set parameter is different from the default parameter.

With buttons (1) and (2) it is possible to select the desired measurement or "Default" to reset the default unit of measurement.

Once the desired function is highlighted, press button (4) to save the selected unit.

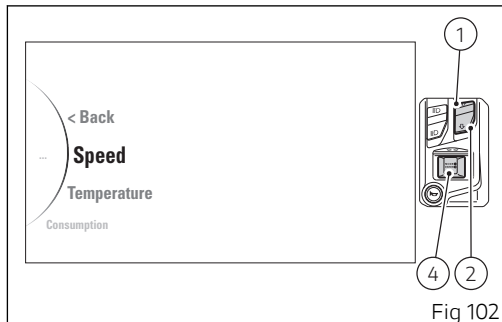

Fig 102

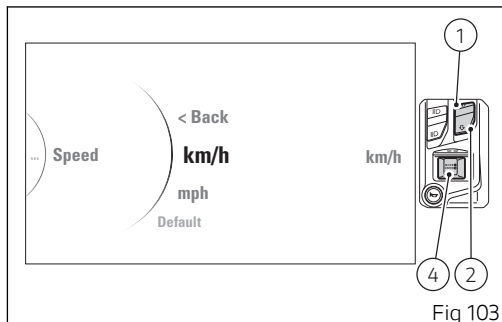

Fig 103

To exit the menu and go back to previous page highlight the "< Back" indication and press button (4).

## Setting the unit of measurement for temperature (Temperature)

This function allows you to change the units of measurement of the temperature.

This page (Fig 105) shows currently set units of measurement on the right side and the following options on the left side:

- < Back
- °F
- °C
- Default
- < Back

"Default" indication is visible only if the set parameter is different from the default parameter.

With buttons (1) and (2) it is possible to select the desired measurement or "Default" to reset the default unit of measurement.

Once the desired function is highlighted, press button (4) to save the selected unit.

To exit the menu and go back to previous page highlight the "< Back" indication and press button (4).

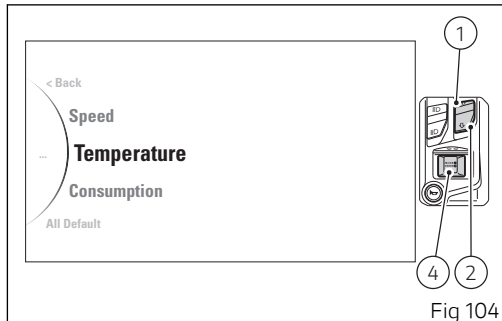

Fig 104

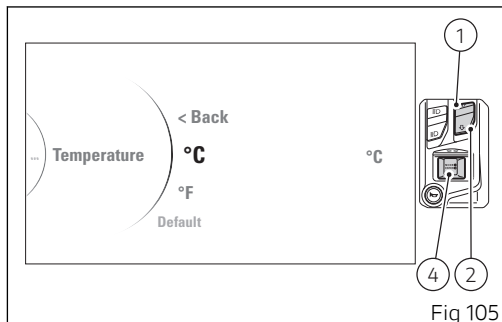

Fig 105



## Setting the unit of measurement for fuel consumption (Consumption)

This function allows you to change the units of measurement of the fuel consumption.

This page (Fig 107) shows currently set units of measurement on the right side and the following options on the left side:

- < Back
- l/100
- km/l
- mpg UK
- mpg US
- Default
- < Back

"Default" indication is visible only if the set parameter is different from the default parameter.

With buttons (1) and (2) it is possible to select the desired measurement or "Default" to reset the default unit of measurement.

Once the desired function is highlighted, press button (4) to save the selected unit.

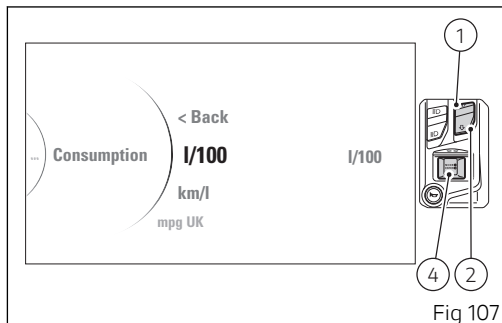
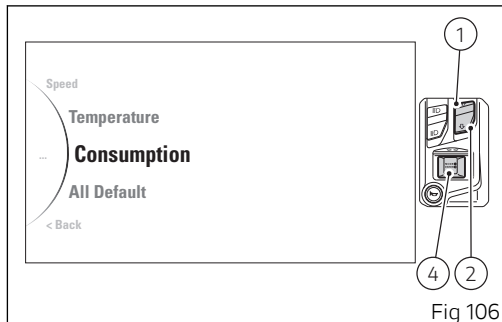

To exit the menu and go back to previous page highlight the "< Back" indication and press button (4).

## Setting menu - service information (Service)

This function informs the user on the deadlines for the indications of Oil Service (in km or miles), Desmo Service (in km or miles) and Annual Service (date).

Enter the setting menu (SETTING MENU).  
Select "Service" option, by pressing button (1) or (2).  
Once function is displayed, press button (4).

When entering this function (Fig 109), the instrument panel will list, for each type of maintenance, the countdown for reaching the maintenance threshold:

- Oil Service with logo and mileage (in km or miles) left before the next threshold;
- Desmo Service with logo and mileage (in km or miles) left before the next threshold;
- Annual Service with logo and expiration date.

To exit the menu and go back to previous page highlight the "< Back" indication and press button (4).

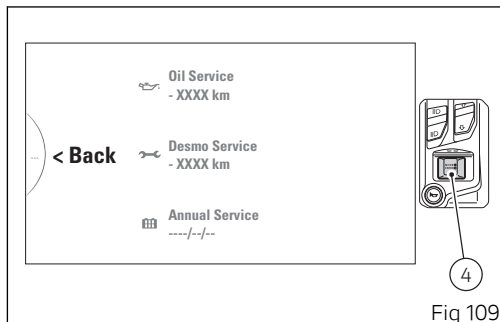
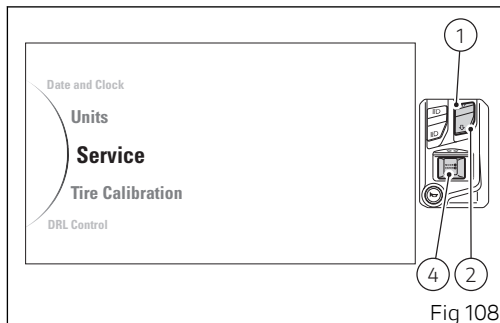

## Setting menu - tyre setting and drive ratio (Tyre Calibration)

This function allows the user to run the procedure for calibrating and teaching in the tyre rolling circumference and final drive ratio.

Enter the setting menu (SETTING MENU).  
Select "Tyre Calibration" option, by pressing button (1) or (2). Once function is displayed, press button (4).

As you enter this function (Fig 111), the instrument panel displays the following indications:

- < Back
- Start
- Default
- < Back

"Default" indication is visible only if the set parameter is different from the default parameter.

To exit the menu and go back to previous page highlight the "< Back" indication using button (1) or (2) and press button (4).

To start the drive ratio and tyre calibration procedure, highlight "Start" option and press button (4).

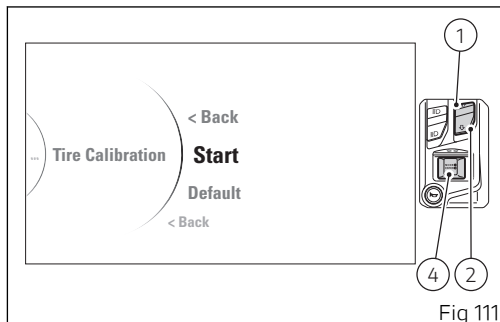
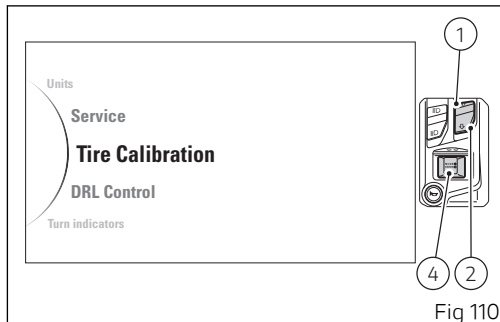

When the calibration procedure starts, the instrument panel displays the message "Ready" flashing, the message "Keep Speed" with speed range and the gear to be maintained by the user to complete the teach-in procedure. On the right the reference Riding Mode, current speed and gear engaged.

### Important

The teach-in procedure is allowed only at a vehicle speed between 48 Km/h (30 mph) and 52 Km/h (32 mph) in the 2nd gear.

When the rider complies with the required conditions of vehicle speed and gear displayed, the instrument panel starts system calibration: all previous information will be displayed showing "In progress" instead of "Ready".

Calibration is performed by keeping speed and gear within the indicated range for 5 seconds.

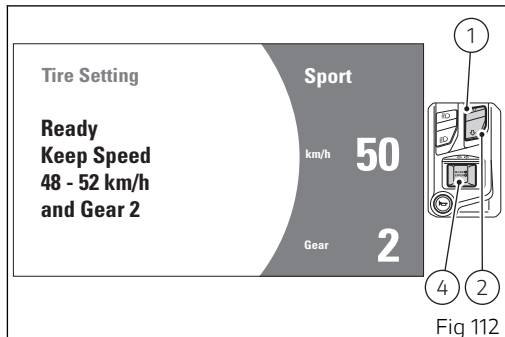

If the teach-in procedure is completed correctly, the instrument panel shows "Completed" followed by the previous screen after a few seconds.

### **Note**

During the calibration procedure, if the vehicle speed exceeds 62 mph (100 km/h), the procedure will stop.

### **Note**

During calibration, the procedure can be aborted and user can go back to standard screen by pressing button (1) for 2 seconds.

### **Note**

If during the calibration procedure a vehicle key-off is performed, the procedure will stop and end with negative result.

If the calibration procedure is aborted by the user, the instrument panel shows "Aborted" (Fig 114) followed by the previous screen after a few seconds.

If, on the other hand, an error or malfunction occurs during the calibration procedure, the instrument

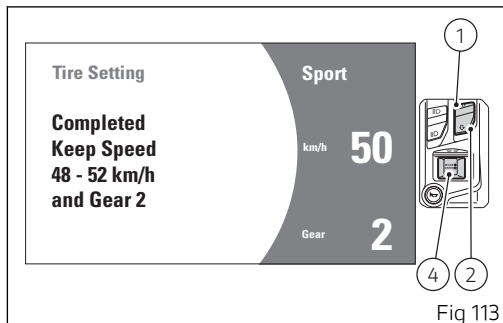

Fig 113

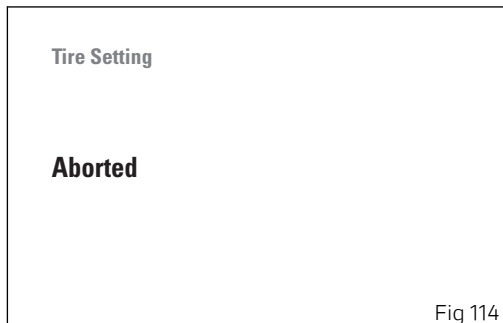

Fig 114

panel shows "Failed" followed by the previous screen after a few seconds.

To reset to the default settings, use buttons (1) and (2) to select "Default" (Fig 111) and press button (4). Then, the instrument panel shows "Default Please Wait..." (Fig 115) and after a while "Default ok" (Fig 116) for 2 seconds, then followed by the previous screen.

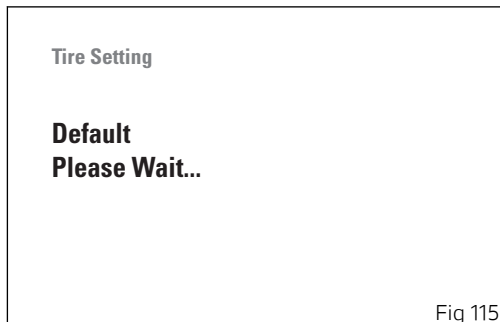

Fig 115

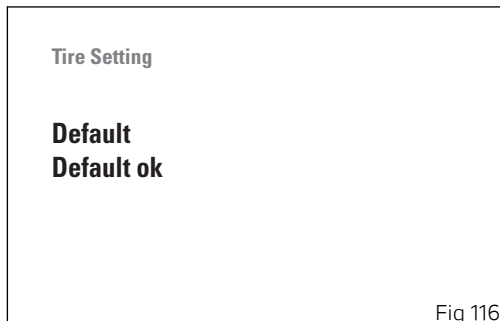

Fig 116



## Setting menu - DRL light mode setting - accessory (DRL Control)

This function is available only if the DRL light is installed and allows setting the DRL control to automatic (Auto) or manual (Manual) mode.

Enter the setting menu (SETTING MENU).  
Select "DRL Control" option, by pressing button (1) or (2). Once function is displayed, press button (4).

As you enter this function, the instrument panel displays the following indications:

- < Back
- Auto
- Manual
- < Back

Use buttons (1) and (2) to select the desired setting:

- by selecting "Auto" the DRL light is automatically switched from the day mode to the night mode and vice versa according to the ambient light;
- by selecting "Manual" the automatic management of DRL light is disabled.

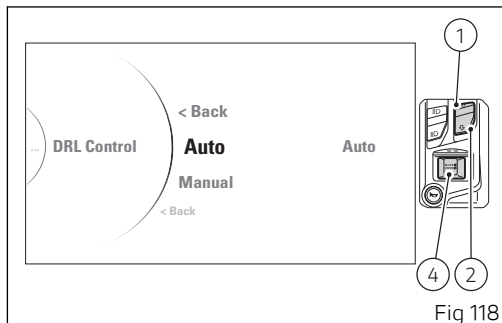
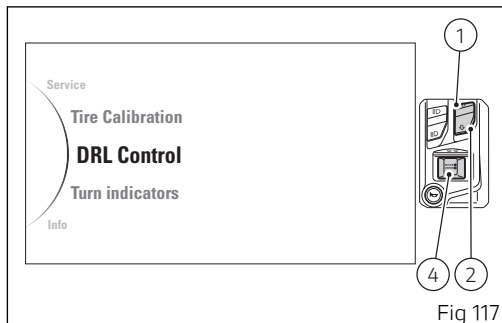

Once required mode is highlighted, press button (4) to confirm.

To exit the menu and go back to previous page highlight the "< Back" indication and press button (4).

### **Note**

This setting ("Auto" or "Manual") remains stored even after Key-Off. In the event of an interruption of the power supply from the battery (Battery Off), when power is restored at the next Key-On, the mode will always be set by default to the "Auto" mode.

## Setting menu - setting Bluetooth devices - accessory (Bluetooth)

This function is available only if the Bluetooth control unit is installed and allows managing the paired devices: visualisation, addition of new devices and removal of devices already paired.

Enter the setting menu (SETTING MENU).

Select "Bluetooth" option, by pressing button (1) or (2). Once function is displayed, press button (4).

As you enter this function, the instrument panel displays the following indications:

- < Back
- Associated Devices
- Pairing
- < Back

Use buttons (1) and (2) to select the desired function:

Select "Associated Devices" and press button (4) to view the list of associated Bluetooth devices, as described in paragraph "Associated devices display and deletion";

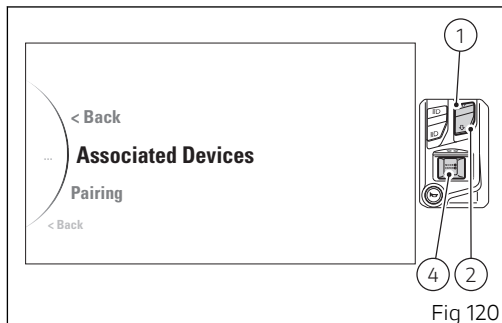
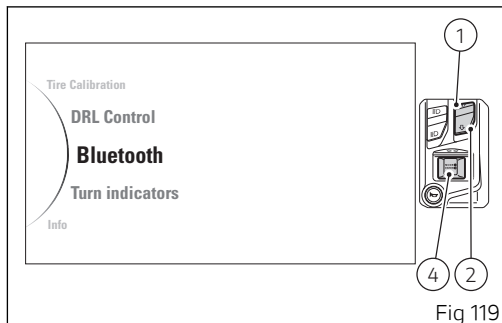

Select "Pairing" and press button (4) to pair new devices, as described in paragraph "Search and pairing of a new device".

To exit the menu, select the "< Back" option and press button (4).

## Associated Devices display and deletion

Enter the setting menu (SETTING MENU).  
Select "Bluetooth" option, by pressing button (1) or (2). Once function is displayed, press button (4). Then select "Associated Devices" and press button (4).

This function displays a list of all associated devices (A): the list can show a maximum of 5 devices. For each device the relevant icon indicating the type is shown on the side. The device can also be deleted. If no associated devices are present, the instrument panel will show "No Device" (B).

The paired devices can be maximum 5:

- 2 smartphones
- 1 rider helmet/intercom
- 1 passenger helmet/intercom
- 1 satellite navigation system

Use button (1) or (2) to scroll the list and select associated devices.

Select from the list the device to be deleted then press button (4) to delete it.

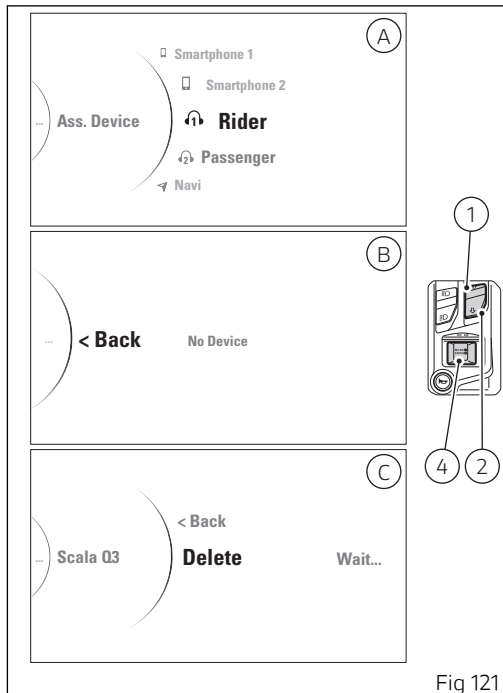

Fig 121

The instrument panel shows the name of the selected device on the left side, "< Back" option and the message "Delete" (C) at the centre.

Press button (4) when "Delete" is selected, to delete the device: "Wait.." message is shown for a few seconds on the right side, then instrument panel will show the updated list of associated devices (A).

If you do not wish to delete it, select the "< Back" option and press button (4).



### **Attention**

Ducati does not ensure a correct connection to the Ducati Multimedia System of Bluetooth navigators that are not provided in the following kits:

- Kit of Ducati Zumo satellite navigator 350
- Kit of Ducati Zumo satellite navigator 390
- Kit of Ducati Zumo satellite navigator 395



### **Note**

The Ducati kits mentioned above can be purchased separately at a Ducati Dealer or Authorised Service Centre.

## Pairing of a new device

This function allows pairing a new Bluetooth device to the instrument panel. The device must be turned on and set so that the instrument panel can detect it. A Bluetooth device in visible mode transmits a wireless signal allowing it to be detected by other devices. This function is called pairing mode. The motorcycle can be equipped with a Bluetooth control unit that works as a hub between the various supported electronic devices relying on a Bluetooth communication interface.

To pair a new Bluetooth device, you must open the **SETTING MENU**.

Select "Bluetooth" option, by pressing button (1) or (2). Once function is displayed, press button (4). Then select "Pairing" and press button (4).



### Attention

Bluetooth Headset device manufacturers may incorporate certain changes within the standard protocols over the course of the lifecycle of the device (Smartphones and Earphones).

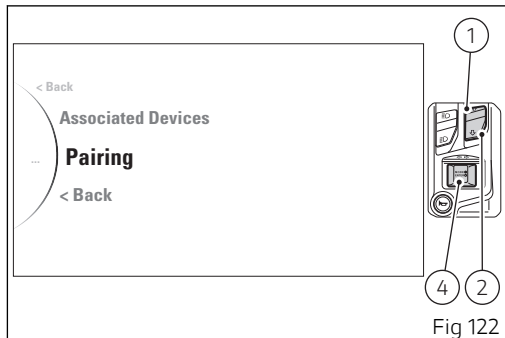

Fig 122



### Attention

These changes are outside the control of Ducati and may result in Bluetooth Headset devices functionality becoming impaired (sharing Music, multimedia player, etc.) and may equally affect some types of Smartphones (depending on supported Bluetooth profiles). This is why Ducati cannot guarantee multimedia player proper operation for:

- any earphones not coming with the "Ducati Kit part no. 981029498";
- any Smartphones not supporting the required Bluetooth profiles (even though paired to earphones coming with the "Ducati Kit part no. 981029498").



### Attention

In case of interference or noise due to particular conditions of the external environment, the Ducati earphone kit part no. 981029498 also allows sharing the music being played directly from rider helmet to passenger helmet (for further details please refer to the manual of the earphones coming with the Ducati kit part no. 981029498).



### Note

The Ducati kit part no. 981029498 can be purchased separately at a Ducati Dealer or Authorised Service Centre.



When entering this function (A), the instrument panel will display the types of devices that can be paired:

- < Back
- Smartphone
- Rider
- Passenger
- Navi
- < Back

Use buttons (1) and (2) to select the type of device for which you wish to start the device search procedure and press button (4).

The instrument panel will start searching for Bluetooth visible devices, and show type of device it is looking for on the left side of the screen, the list of identified devices at the centre and "Wait.." message on the left side, which remains until search is completed.

At the end of this operation, a list of all found devices that can be paired is displayed (B). The list may include a maximum of 20 devices.

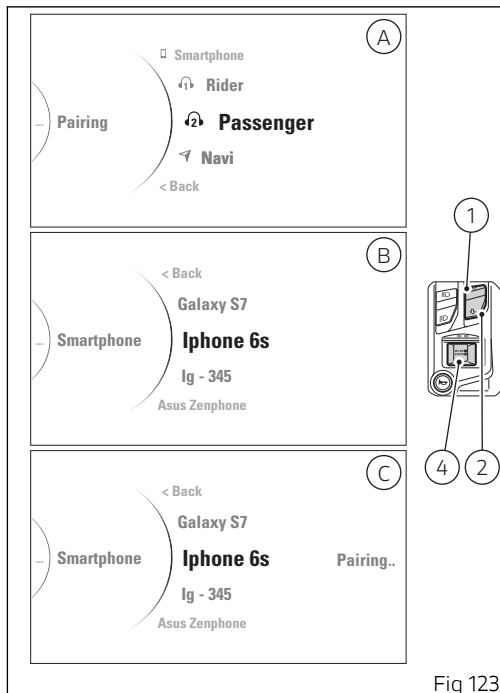

Fig 123

Use buttons (1) and (2) to select the desired device and press button (4) to start the pairing procedure. The display shows the message "Pairing.." on the right side (C).

As soon as the procedure is completed, the device is added to the list of associated devices (A, Fig 121) and the instrument panel goes back to the previous page (A, Fig 123).

If Pairing is not successful, the "Pairing error" message will be displayed.

If you wish to connect a Bluetooth navigator, the connection procedure shall be completed on the navigator, by selecting the connection with the motorcycle Bluetooth control unit. If user does not complete the pairing procedure on the Navigator side within 90 seconds, pairing procedure cannot be completed.

## Setting menu - turn indicator mode setting (Turn Indicators)

This function allows user to set the strategy for automatically switching off the turn indicators based on lean angle, vehicle speed and distance run to automatic mode or manual mode.

Enter the setting menu (SETTING MENU).  
Select "Turn Indicators" by pressing button (1) or (2).  
Once function is displayed, press button (4).

As you enter this function, the instrument panel displays the following indications:

- < Back
- Auto
- Manual
- < Back

Use buttons (1) and (2) to select the desired setting:

- by selecting "Auto", the system activates the self-cancel strategy of the turn indicators;
- by selecting "Manual", the system disabled the self-cancel strategy of the turn indicators (so the turn indicators can be turned off manually only by pressing the dedicated button).

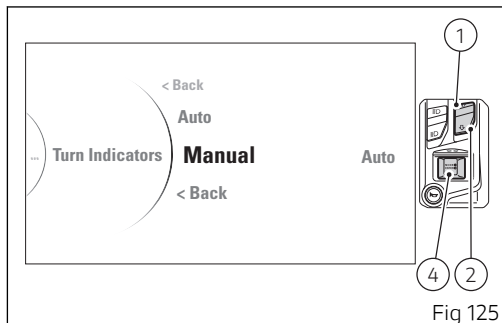
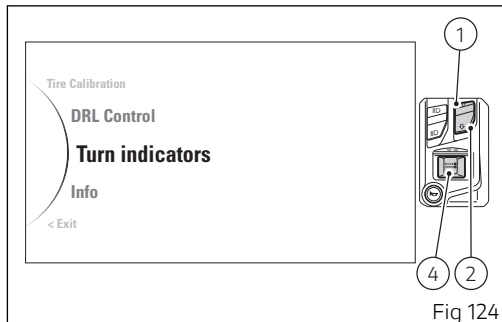

Once the desired function is highlighted, press button (4) to set the selected mode.

To exit the menu and go back to previous page highlight the "< Back" indication and press button (4).

### **Note**

This setting ("AUTO" or "MANUAL") remains stored even after Key-Off. In the event of an interruption of the power supply from the battery (Battery Off), when power is restored at the next Key-On, the mode will always be set by default to the "AUTO" mode.

### **Note**

The strategy for automatically switching off the turn indicators is not active if all turn indicators are on at the same time (Hazard function).

## Setting menu - information (Info)

This function allows viewing the vehicle battery voltage and the RPM "digital" indication.

Enter the setting menu (SETTING MENU).  
Select "Info" option, by pressing button (1) or (2).  
Once function is displayed, press button (4).

When entering this function, the instrument panel displays:

- "Battery" with battery voltage value;
- "rpm" with the number of engine rpm in digital format.

To exit the menu and go back to previous page, press button (4).

"Battery" information is displayed as follows:

- if the battery voltage is equal to or lower than 10.9 V, the "LOW" message will be displayed in red and flashing;
- if battery voltage is between 11.0 V and 11.7 V the reading will be displayed in red and flashing;
- if battery voltage is between 11.8 V and 14.9 V the reading will be displayed steadily with the battery icon on a standard background;

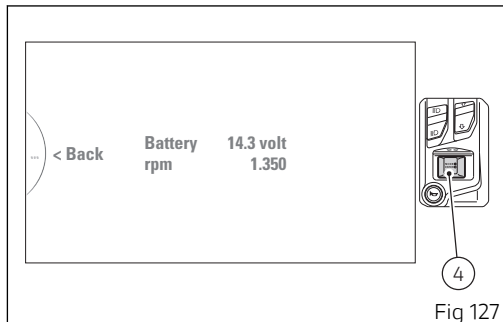
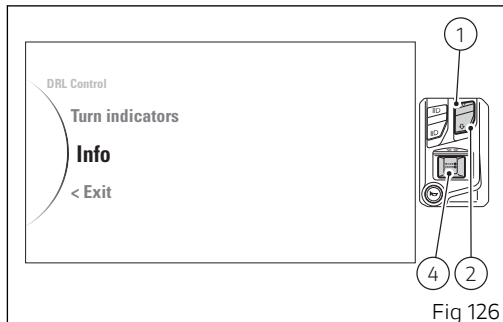

- if battery voltage is between 15.0 V and 16.0 V the reading will be displayed in red and flashing;
- if the battery voltage is equal to or higher than 16.1 V, "HIGH" will be displayed in red and flashing.

The engine "rpm" indication in digital format is recommended for improved accuracy when setting idle rpm.

The display shows the numerical value of the engine rpm with a precision of 50 rpm.

If the instrument panel is not receiving RPM value, a string of five steady dashes "- - - -" is displayed to indicate an undefined reading.

## Lap time (Lap)

To activate the Lap function, refer to chapter "Setting menu - lap timer (Lap)" page 125.

When the Lap function is activated, the timer is displayed on the main screen indicating 0'00.00 as well as the lap number with first indication "Lap - -". When button (3) is pressed for the first time, the lap timer starts with a tenth-of-a-second resolution and the Lap number in progress is displayed. Both data flash for 4 seconds and then remain steady on.

Every time button (3) is pressed again, the display shows the number and time of the just-ended lap for 6 seconds.

Then the timer and the number of the new current lap are displayed again.

If lap timer is active but motorcycle is at standstill, lap timer is stopped after 5 seconds and it is displayed with the initial indication 0'00.00 and the lap number "Lap - -".

The next time rider pushes button (3), the lap timer is reactivated.

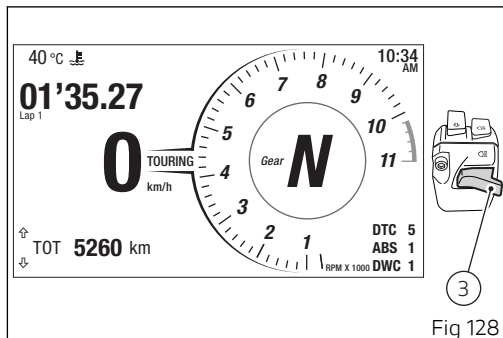

Fig 128



### Note

When LAP function is active, button (3) takes on the dual function of high beam Flash and LAP timer Start/Stop.

It is possible to record the lap time, for a total of 30 consecutive laps.

Laps are numbered from 01 to 30: when lap 30 is reached, "FULL" is displayed steadily when button (3) is pressed.

To delete the recorded laps, refer to paragraph "Setting menu - lap timer (Lap)" page 125.

The instrument panel disables the Lap function in the following cases:

- through the relevant On/Off function via the setting menu;
- after deleting the stored Laps via setting menu;
- after a Key-Off;
- upon any power off.

If lap timer is not stopped, it will reach 9mins, 59secs, 99hunds and then restart from zero and continue until the function is disabled using one of the methods above.





If the Lap function is switched on and the memory has not been cleared, but fewer than 30 laps have been saved (e.g. 18 laps stored), the instrument panel will keep on recording the remaining laps, starting from the first position available until memory is full (in this example, a maximum of another 12 laps can still be stored).



## Infotainment - accessory

If the Bluetooth control unit is installed, the Bluetooth symbol  is displayed on the instrument panel.

The instrument panel is equipped with an infotainment system that allows managing up to 4 Bluetooth connected devices of different type at the same time:

- 1 smartphones 
- 1 rider helmet/intercom 
- 1 passenger helmet/intercom 
- 1 satellite navigation system 

After connection, they are displayed as follows:

- 1) Smartphone connected;
- 2) Rider helmet earphones connected;
- 3) Passenger helmet earphones connected;
- 4) Rider helmet earphones connected and passenger helmet earphones associated;
- 5) Passenger helmet earphones connected and rider helmet earphones associated;
- 6) Rider helmet and passenger helmet earphones connected;

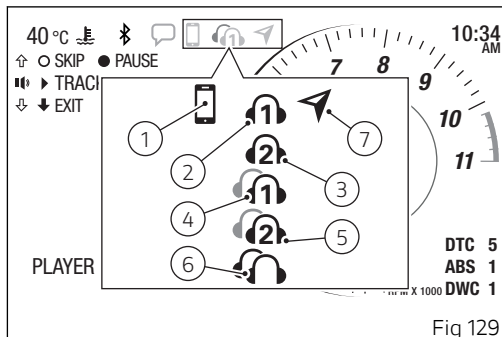

Fig 129

7) Ducati GPS navigator connected.

To pair or remove Bluetooth devices, refer to the chapter "Setting menu - Bluetooth device settings - accessory (Bluetooth)" on page 154.

If a smartphone is connected to the instrument panel via Bluetooth, the system allows managing the music player (page 84) and the list of the last calls (page 91).



Below is a description of what the instrument panel will do in the following cases:

- Incoming call

- Call in progress
- Recall last number (RECALL)
- Missed call
- Message/e-mail received

## Infotainment – Incoming call

If a call is received while the smartphone is connected via Bluetooth to the instrument panel the display will show:

- the message "ACCEPT" next to the arrow  (A)
- the name/number of the person calling (B)
- the message "DECLINE" next to the arrow  (C)

It is possible to answer or reject an incoming call using buttons (1) and (2). In particular:

- to answer the call press button (1)
- to reject the call press button (2)

### Note

During an incoming call, button (1) and button (2) are used to answer or reject the call and not for the "standard" instrument panel functions.

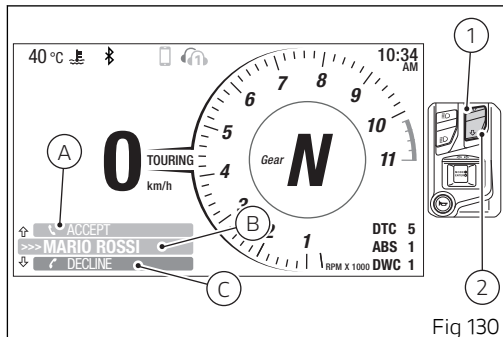

## Infotainment – Call in progress

When answering a call, the instrument panel will display:

- "ACTIVE" indication (A)
- the name/number of the person calling preceded by ">>>" (B)
- the option "END CALL" next to the arrow ⇓ (C)

To end the call press button (2).

When making a call (for example through the LAST CALLS or RECALL functions), the instrument panel displays:

- "ACTIVE" indication (A)
- the name/number of the person calling preceded by "<<<" (B)
- the option "END CALL" next to the arrow ⇓ (C)

To end the call press button (2).

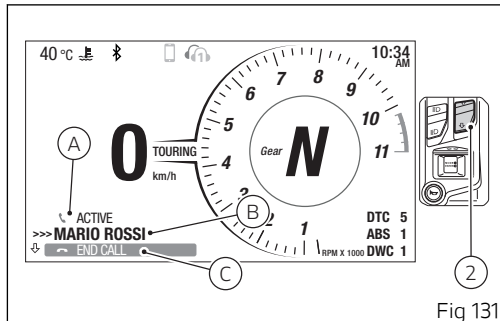

Fig 131

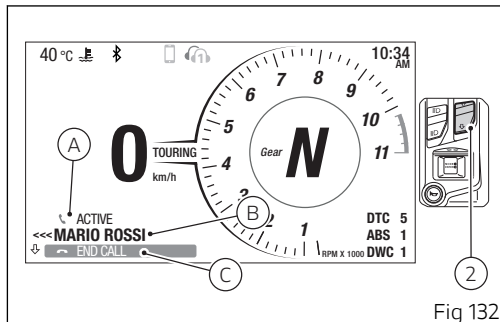

Fig 132



## Note

If the rider helmet/intercom is connected in addition to the smartphone, the phone call will take place through the helmet headphones and microphone.

## Infotainment - Recall last number (RECALL)

When a phone call is ended, missed or rejected, the instrument panel activates the RECALL function for 5 seconds that allows recalling the last number.

The display shows:

- the option "RECALL" (A) next to the arrow 
- the name/number of the person calling preceded by "<<<" when making a call, or preceded by ">>>" when receiving a call (B)

Press button (1) to call the last name/number displayed.

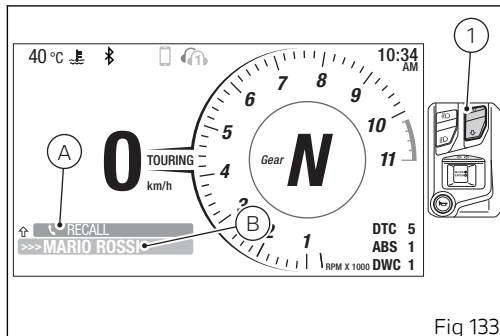

Fig 133

## Infotainment – Missed call

The instrument panel will notify the user about a missed call by activating the symbol (A) for 60 seconds, with the first 3 seconds flashing.

### **Note**

The number of missed calls is not displayed.

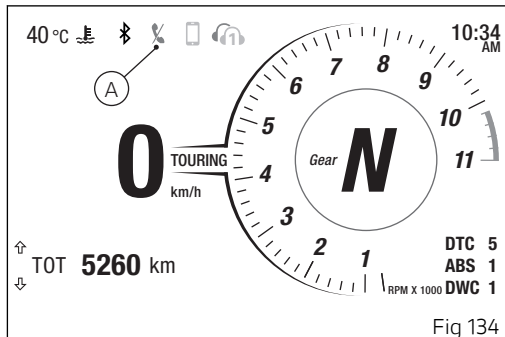

Fig 134

## Infotainment - Message/e-mail received

The instrument panel will notify the user about a received message or e-mail by activating the symbol (A) for 60 seconds, with the first 3 seconds flashing.

### Note

The number of received messages or e-mails is not displayed.

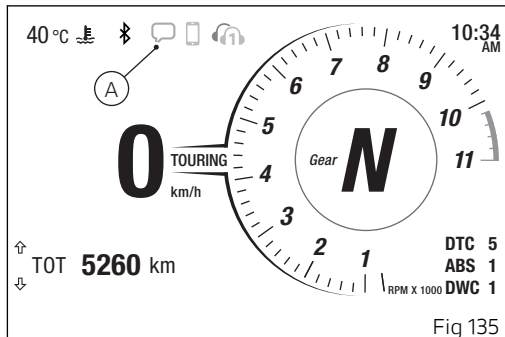



## Service indication (SERVICE)

This indication shows the user that the motorcycle is due for service and must be taken to a Ducati Authorised Service Centre.

The service warning indication can be reset only by the Authorised Ducati Service Centre during servicing.

The types of maintenance operations are displayed in the area indicated in the figure and are as follows:

- OIL SERVICE countdown
- OIL SERVICE
- ANNUAL SERVICE countdown
- ANNUAL SERVICE
- DESMO SERVICE countdown
- DESMO SERVICE

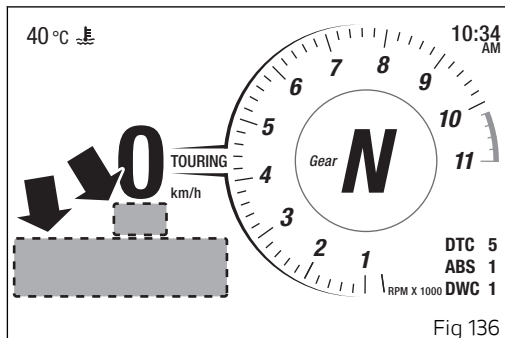

Fig 136

## Indication of Oil Service, Date Service and Desmo Service COUNT DOWN

When the set service thresholds are close, the instrument panel activates the following yellow warnings for 5 seconds upon every Key-ON:

- the OIL SERVICE (A) indication with the count of the remaining mileage in kilometres (miles) instead of the odometer (TOT), 1000 km (600 mi) earlier than the service threshold;
- the ANNUAL SERVICE (B) indication with the count of the remaining days, 30 days earlier than the service threshold;
- the DESMO SERVICE (C) indication with the count of the remaining mileage in kilometres (miles) instead of the odometer (TOT), 1,000 km (600 mi) earlier than the service threshold;

It is possible to view in the Setting menu the deadlines for the service coupons (Oil Service in Km or miles, Desmo Service in Km or miles and Annual Service in year/month/day): see "Setting menu - service information (Service)" page 146.

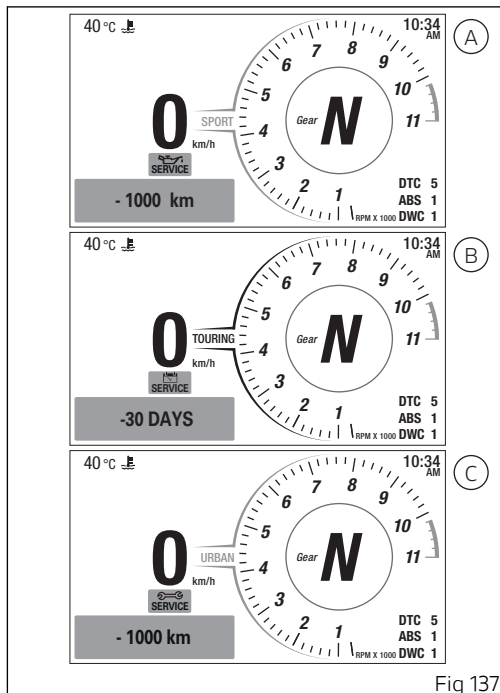

Fig 137

## Indication of Oil Service, Date Service and Desmo Service

When the service threshold is reached, the warning for the type of service required is triggered:

- OIL SERVICE (A);
- ANNUAL SERVICE (B);
- DESMO SERVICE (C).

Required service warning is triggered and displayed in red until "Reset" by the Ducati authorised service centre, during maintenance.

It is possible to view in the Setting menu the deadlines for the service coupons (Oil Service in Km or miles, Desmo Service in Km or miles and Annual Service in year/month/day): see "Setting menu - service information (Service)" page 146.

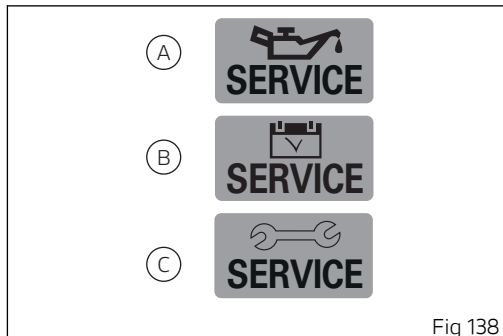

## DRL automatic mode indication - accessory

This function is available only if the DRL light is installed and indicates if the DRL light is set to "AUTO"

Through the setting menu it is possible to change the control mode of the DRL light, refer to the chapter "Setting menu - DRL light mode setting - accessory (DRL Control)" on page 152.

When the DRL is set to "AUTO mode", the instrument panel shows the green warning light (A).

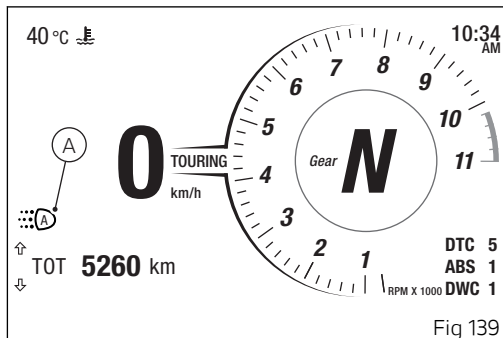
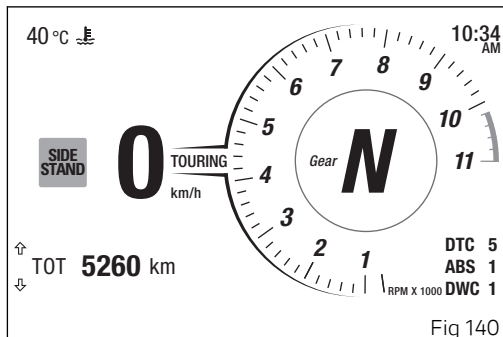

Fig 139

## Viewing side stand status

If side stand is down/open, the instrument panel shows icon "SIDE STAND on a red background.

If instrument panel does not receive side stand status, "SIDE STAND" icon will flash to indicate an undefined status.



## Warnings and Alarms

The instrument panel manages a number of warnings / alarms, aimed at giving useful information to the rider during use.

Upon Key-On, if there are active warnings the instrument panel displays the indication of the present warnings.

When a warning is triggered, the instrument panel will show the warning in a big size for the first 5 seconds and then permanently in a small size.

If several warnings are active, the corresponding icons will be displayed one after the other, each remaining on display for 3 seconds.

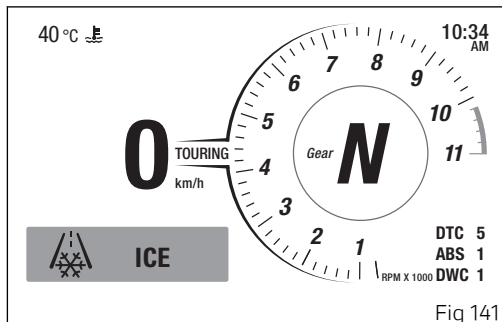

Fig 141

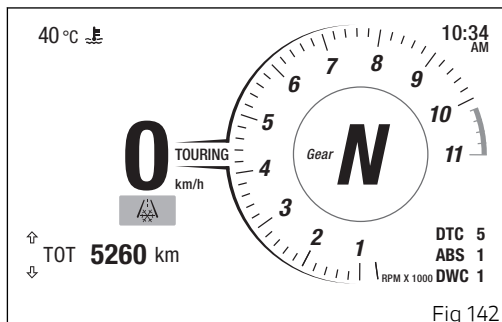

Fig 142

## Ice on the road indication (ICE)

This function warns the rider when there might be ice on the road, due to the low external temperature. This warning turns on when temperature drops to 4°C (39°F) and turns off when temperature rises to 6°C (43°F).



### Attention

This warning does not eliminate the possibility of icy road areas even with temperatures above 4°C (39°F); when ambient temperature is "low", ride responsibly, especially on road areas not exposed to sunlight and/or on bridges.

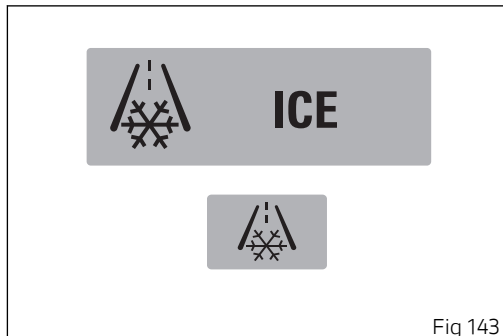

Fig 143

## Low battery indication (LOW BATTERY)

This function warns the user that the status of the vehicle battery is low.

Warning is activated when battery voltage is lower than/equal to 11.0 Volt.



### Note

In this case, Ducati recommends charging battery in the shortest delay using the special instrument as engine could not be started.

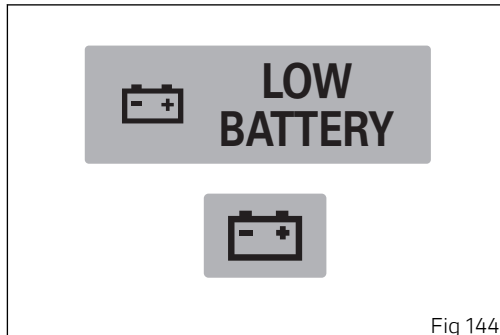



## Entering the Date (INSERT DATE)

This function prompts the user to enter the date via the setting menu.



### Note

In this case Ducati recommends to stop and enter the calendar date using the function "Date setting (Date and Clock)".

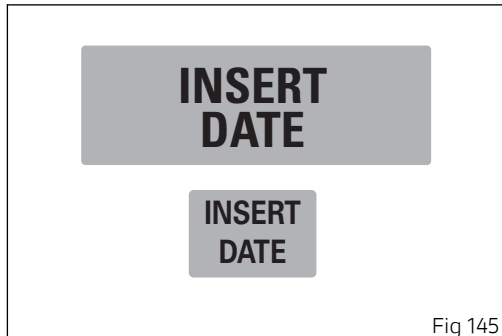

Fig 145

## Errors

The instrument panel manages error warnings in order to allow the rider to identify any abnormal motorcycle behaviour in real time.

Upon Key-On, in case of errors, the instrument panel turns on the MIL light (A) (in case of errors directly connected to the engine control unit) or the Generic Error light (B) (in case of any other errors).

During normal operation, when an error is triggered, the instrument panel turns on the MIL light (A) or the Generic Error light (B).



### Attention

When one or more errors are displayed, always contact a Ducati Dealer or authorised Service Centre.

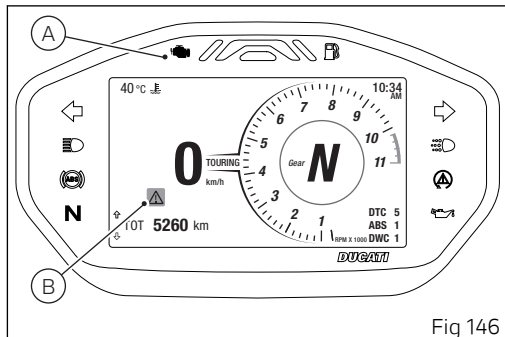

Fig 146

## Light control

### Low/high beam (version without DRL)

At Key-On, the high beam and low beam lights are OFF: only the parking lights are turned on. When the engine is started the low beam is automatically switched on. It is possible to switch from low to high beam and vice versa with button (7), positions (B) and (A), or flash with button (3). If engine is not started upon key-on, it is anyway possible to switch low/high beams on by pushing button (7), positions (B) and (A), or flash with button (3) on LH switch.

If within 60 seconds from the manual switching on of the low / high beam the engine is not started, the lights are disabled again (off).

To preserve the motorcycle battery, if when starting the engine the high/low beams are on, the headlight is automatically switched off and then on again when the engine is started.

### Low/high beam (version with DRL)

At Key-On, the high beam and low beam lights are OFF: only the parking lights and the DRL light are turned on.

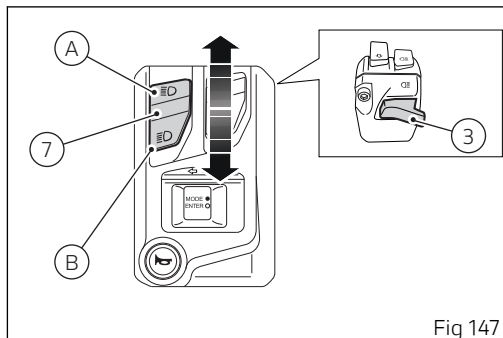

After starting the engine the low beam is automatically switched on if the AUTO mode is set and the instrument panel detects poor ambient light (NIGHT): if, on the other hand, the instrument panel detects good light conditions (DAY), the DRL light remains on and the low beam remains off.

If within 60 seconds from the "manual" switching on of the low / high beam the engine is not started, the lights are disabled again (off).

If the low beam is activated, it is possible to switch on the high beam with button (7, Fig 147) position (A), or flash with button (3, Fig 147).

If engine is not started upon key-on, it is anyway possible to switch low/high beams on by pushing button (7, Fig 147) positions (B) and (A), or flash with button (3, Fig 147) on LH switch.

To preserve the motorcycle battery, if when starting the engine the high/low beams or the DRL lights are ON, the headlight is automatically switched off and then on again when the engine is started.

DRL (Daytime Running Light) in AUTO mode – only for version with DRL lights

If the DRL was set to AUTO via the setting menu, the instrument panel automatically manages (according to detected ambient light) the DRL and the low beam:

- if the instrument panel detects good light conditions (day) the DRL is turned on and the low beam is turned off;
- if the instrument panel detects poor light conditions (night) the DRL is turned off and the low beam is turned on.

In this mode, the instrument panel automatically switches from DRL to low beam and vice versa, depending on detected ambient light. When the DRL is on and set to AUTO mode, the display shows the green warning light (A).

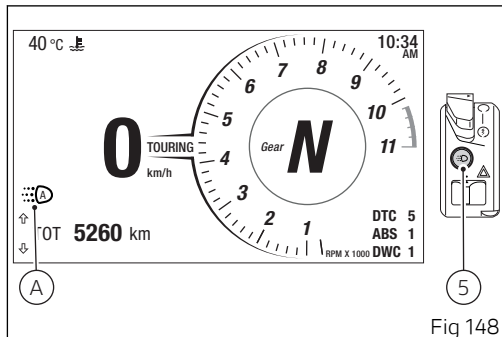

Fig 148



### Attention

Using the DRL light in AUTO (automatic) mode in case of poor light conditions, especially in case of fog or clouds, could impair safety: in this case DUCATI recommends to manually activate the low beam.

If the DRL was set to AUTO mode via the setting menu, press button (5) to disable that mode and set a "normal" light management. Press again button (5) to re-enable DRL but with control strategy set to MANUAL.

In this case, upon Key-Off and Key-On, DRL will be again set to AUTO mode.

DRL in Manual mode – only for version with DRL light

If the DRL light is in this mode, because set through the setting menu page 152, it does not change its status when the engine is started.

To switch on or off the DRL light, it is necessary to press button (5, Fig 148).



### **Attention**

Using the DRL light in poor light conditions (dark) could compromise the riding visibility and dazzle who is coming on the opposite lane.



### **Note**

Using the DRL light during the day improves visibility as it is easier to perceive by those coming on the opposite side compared with the low beam.

## Turn indicators

The instrument panel manages the turn indicators in manual or automatic mode according to what set through the setting menu - see chapter "Setting menu - turn indicator mode setting (Turn Indicators)" on page 162.

### Manual switch-off:

After activating one of the two turn indicators, the user can deactivate them using button (4).

### Automatic switch-off:

#### Automatic switch-off:

The turn indicators switch off automatically after the turn, as calculated based on vehicle speed, lean angle and in general according to the analysis of vehicle dynamic conditions.

If the turn indicator switch is again operated, while turn indicator is still on, automatic switch-off feature is re-initialised.

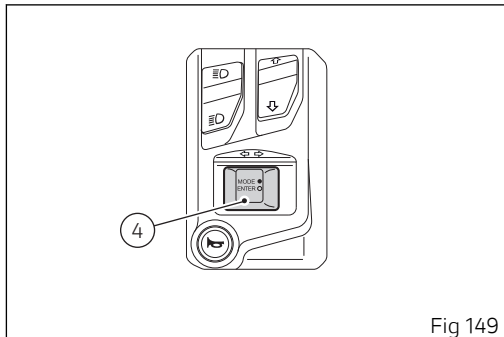

Fig 149



### Attention

The automatic deactivation systems are assist systems helping the rider control the turn indicators in the most comfortable and easy way. Such systems have been designed to work in most riding manoeuvres, nonetheless the rider must pay attention to the turn indicator operation (disabling or enabling them by hand if needed).



## Hazard function (4 turn indicators)

The Hazard function turns all four turn indicators on at the same time to signal an emergency condition. This function is activated by pressing button (6). When the Hazard function is active, all four turn indicators blink at the same time as well as the warning lights on the instrument panel (warning lights 6, "Instrument panel").

If during the Key-On the Hazard function has been activated, it will carry on working also after the Key-Off.

If the function is active in Key-Off, its deactivation is carried out only automatically after 120 minutes. In Key-Off it is not possible to activate the Hazard function.

### Note

If user performs a Key-ON while the "Hazard" function is still active, the function will remain ON (temporary turn indicator control interruption is allowed during the instrument panel initial check routine).

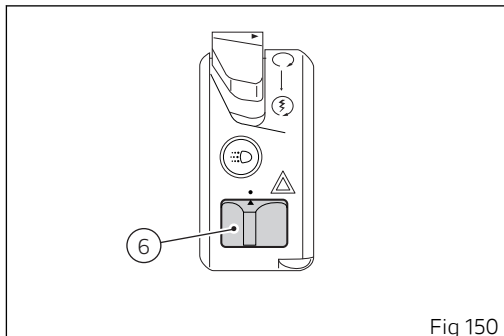

Fig 150

### Note

If there is a sudden interruption in the battery while the function is active, the instrument panel will disable the function when the voltage is restored.

### Note

The "Hazard" function has higher priority compared to normal operation of the single turn indicators, this means that, as long as it is active, it will not be possible to activate the single right or left turn indicators.

## **Immobilizer system**

To further improve the anti-theft protection, the motorcycle is equipped with an engine electronic block system (IMMOBILIZER) that is automatically activated every time the instrument panel is switched off.

Inside of each key handgrip there is an electronic device that modulates the signal sent by a special antenna integrated in the ignition switch upon starting.

Such modulated signal represents the "password", that changes upon every starting, that allows the control unit to acknowledge the key and thus starting the engine.

## Keys

The motorcycle comes with 2 keys.

They contain the "Immobilizer system code".

Keys (B) are those for the standard use, i.e. to:

- start the engine;
- open the fuel tank plug;
- open the seat lock.



### Attention

Separate the keys and use only one of the two to ride the bike.

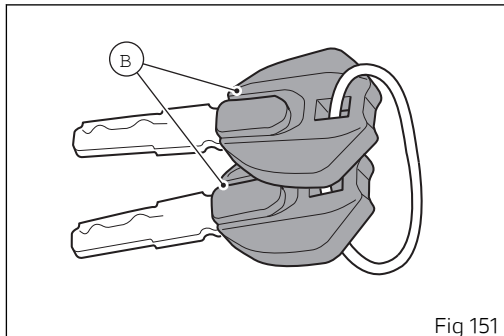

Fig 151

## Key duplication

When a customer needs spare keys, he/she shall contact a Ducati authorised service centre and bring all keys he/she still has.

The Ducati authorised service centre will program all new and old keys.

The Ducati authorised service centre may ask the customer to prove to be the motorcycle owner.

The codes of the keys missing during the programming procedure will be erased to ensure that any lost key can not start the engine.



### Note

If the motorcycle owner changes, it is necessary that the new owner is given all keys.

## Restoring motorcycle operation via the PIN CODE

In case of key acknowledgement system or key malfunction, the instrument panel allows the user to enter his/her own PIN code to temporarily restore motorcycle operation.

if the PIN CODE function is active, the instrument panel displays "Insert Pin" with four spaces allowing the rider to enter digits of the Pin code to be entered. "0" and "- - -".

Entering the code:

- 1) Each time you press the button (1) the displayed number increases by one (+ 1) up to "9" and then starts back from "0";
- 2) Each time you press the button (2) the displayed number decreases by one (- 1) up to "0" and then starts back from "9";
- 3) To confirm the number, press the button (4).

Repeat the procedures until you confirm all the 4 digits of the PIN CODE.

When you press button (4) to confirm the fourth and last digit:

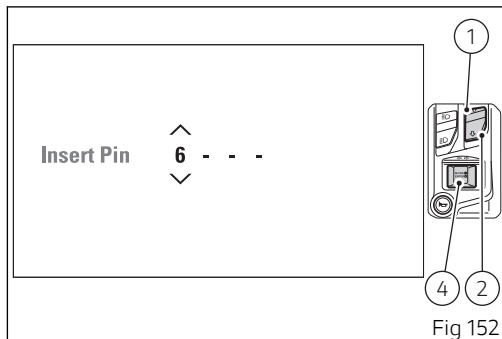

- if there is a problem during the PIN code check, the instrument panel displays "ERROR" for 2 seconds and then passes to the standard screen.
- if the PIN is not correct, the instrument panel displays WRONG for 2 seconds and then goes back to the "Insert Pin" indication with spaces to enter again the four digits of the Pin code.
- if the PIN CODE is correct, the instrument panel shows CORRECT for 2 seconds, and then displays the "standard screen".



## **Important**

If this procedure is necessary in order to start the motorcycle, contact an Authorised Ducati Service Centre as soon as possible to fix the problem.

# Controls

## Position of motorcycle controls



### Attention

This section shows the position and function of the controls used to ride the motorcycle. Be sure to read this information carefully before you use the controls.

- 1) Instrument panel.
- 2) Key-operated ignition switch and steering lock.
- 3) Left-hand switch.
- 4) Clutch lever.
- 5) Rear brake pedal.
- 6) Right-hand switch.
- 7) Throttle twistgrip.
- 8) Front brake lever.
- 9) Gear change pedal.

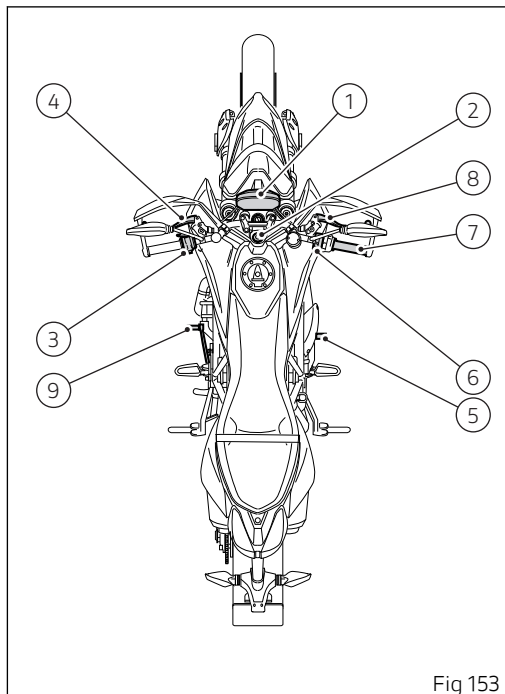





Fig 153

## Key-operated ignition switch and steering lock

It is located in front of the fuel tank and has four positions:

- A)  : enables lights and engine operation;
- B)  : disables lights and engine operation;
- C)  : the steering is locked;
- D)  : parking light and steering lock.

### Note

To move the key to the last two positions, press it down before turning it. The key can be removed in positions (B), (C) and (D).

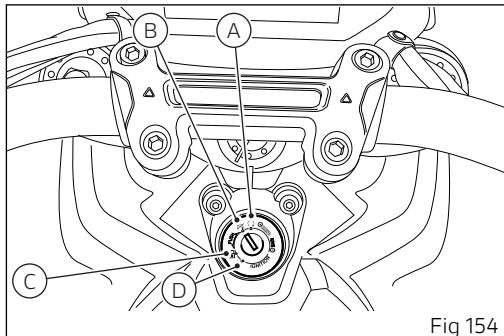







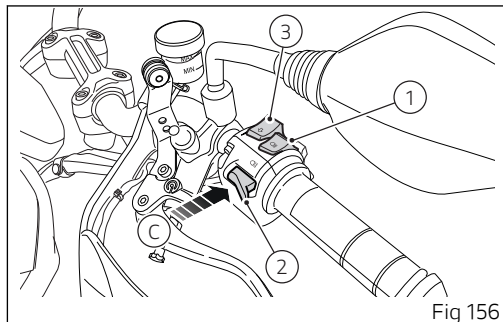
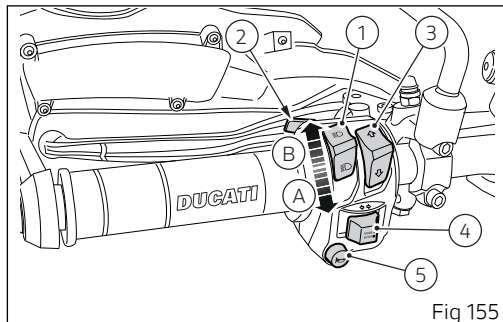

Fig 154



## Left-hand switch

- 1) dip switch, two-position light selector switch:  
position  = low beam on (A);  
position  = high beam on (B);
- 2) Button  = high-beam flasher (FLASH) and instrument panel control (C).
- 3) Instrument panel control switch, position UP "▲" and DOWN "▼";
- 4) Switch  = 3-position turn indicator control:  
centre position = OFF;  
position  = left turn;  
position  = right turn.  
To disable the turn indicator, press the control once it returns to centre position.
- 5) Button  = warning horn.



## Clutch lever

Pull lever (1) towards the handgrip to activate the clutch.

The system is hydraulically operated and you just need to pull the lever gently.

The brake lever has a dial adjuster (2) for adjusting the distance between lever and twistgrip on the handlebar.

The lever distance can be adjusted through 10 clicks of the dial (2).

Turn clockwise to increase lever distance from the handgrip. Turn the adjuster counter clockwise to decrease lever distance.

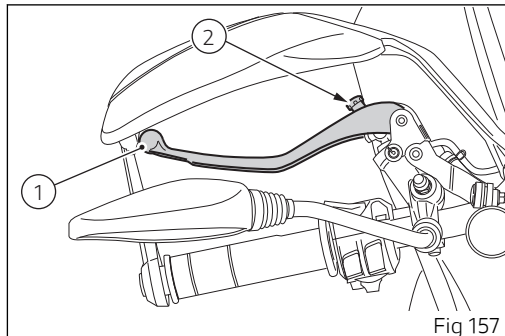

### Attention

Before using these controls, thoroughly read instructions under paragraph "Moving off".

### Attention

Set front brake (clutch) lever when motorcycle is stopped.

## Right-hand switch

- 1) Red ON/OFF switch.
- 2) DRL light button.
- 3) Hazard button.

The switch (1) has three positions:

position up: KILL ENGINE;  
central position: ENGINE ENABLING;  
pushed down: ENGINE START.

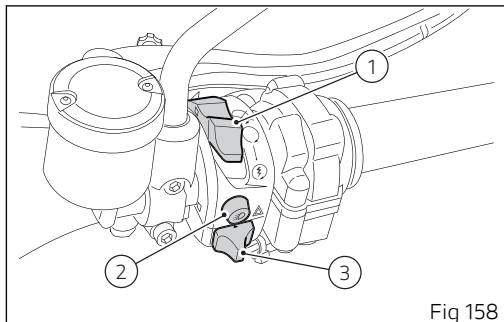

Fig 158

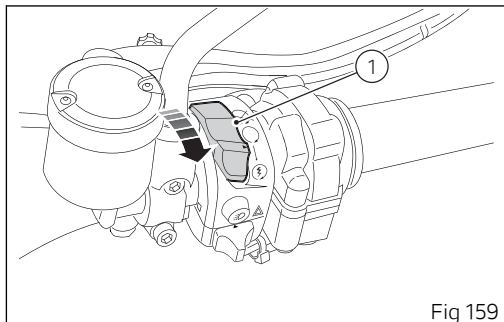

Fig 159

## Throttle twistgrip

The twistgrip (1) on the right handlebar opens the throttles. When released, it will spring back to the initial position (idling speed).

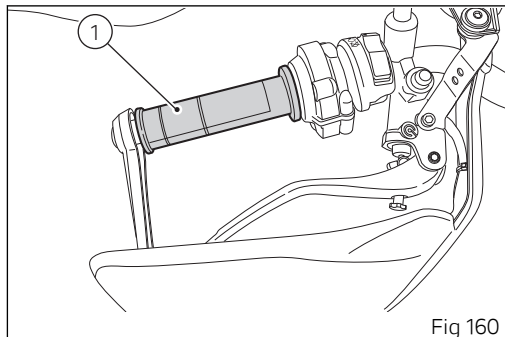

Fig 160

## Front brake lever

Pull in the lever (1) towards the twistgrip to operate the front brake. The system is hydraulically operated and you just need to pull the lever gently. The brake lever has a dial adjuster (2) for adjusting the distance between lever and twistgrip on the handlebar.

The lever distance can be adjusted through 10 clicks of the dial (2).

Turn clockwise to increase lever distance from the twistgrip.

Turn the adjuster counter clockwise to decrease lever distance.

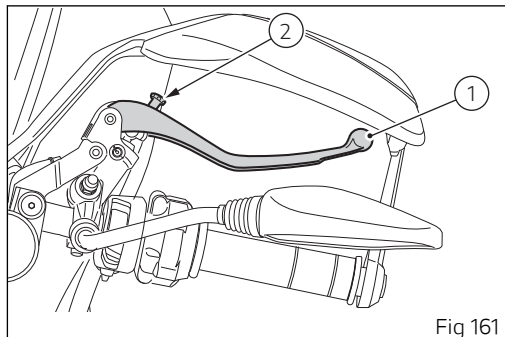

### Attention

Before using these controls, thoroughly read instructions under "Moving off".

### Attention

Set front brake lever when motorcycle is stopped.

## Rear brake pedal

Push down the pedal (1) to operate the rear brake.  
The control system is of the hydraulic type.

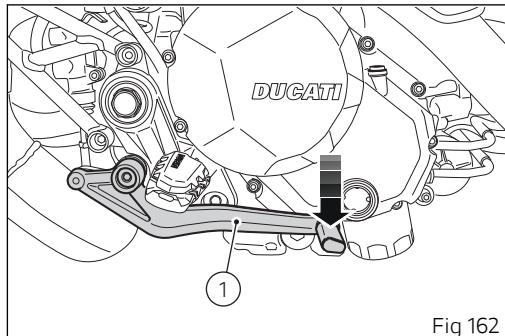

Fig 162

## Gear change pedal

When released, the gear change pedal automatically returns to rest position N in the centre. This is indicated by the instrument panel light N coming on. The pedal can be moved:

- down = press down the pedal to engage the 1<sup>st</sup> gear and to shift down. The N light on the instrument panel will go out;
- upwards= lift the pedal to engage 2<sup>nd</sup> gear and then 3<sup>rd</sup>, 4<sup>th</sup>, 5<sup>th</sup> and 6<sup>th</sup> gears.

Each time you move the pedal you will engage the next gear.

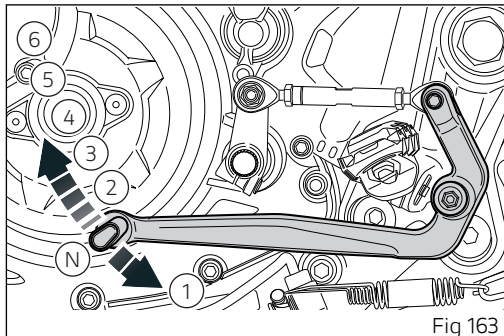

Fig 163

## Adjusting the position of the gearchange pedal and rear brake pedal

The position of the gearchange and rear brake pedals in relation to the footrests can be adjusted to suit the requirements of the rider.

Adjust the pedals as follows:

Gear change pedal

### Note

Nut (2) has a left-hand thread.

Loosen lock nuts (2) and (3).

Fit an open-end wrench to flat (A) and rotate linkage (1) until setting pedal in the desired position.

Tighten both lock nuts (2) and (3) onto linkage.

Once the adjustment is completed, check the correct value (A) that must be:

A = 95 mm ( $\pm 3$  mm) / (3.74 in) ( $\pm 0.12$ ).

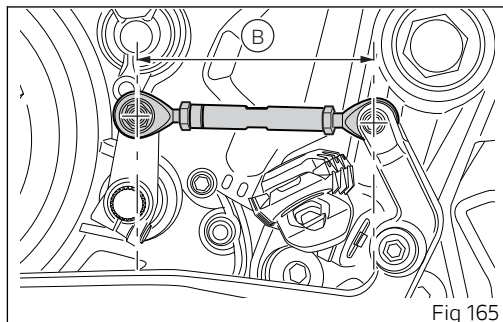
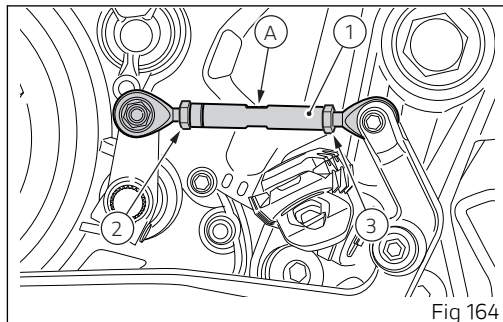



## Rear brake pedal

Loosen lock nut (7).

Turn pedal stroke adjusting screw (6) until pedal is in the desired position. Tighten the counter nut (7).

Operate the pedal by hand to check that there is 1.5 to 2 mm of free play before the brake bites. If not, adjust the length of the master cylinder control rod as follows.

Loosen lock nut (10) on master cylinder rod.

Tighten rod (8) on fork (9) to increase clearance or loosen it to decrease it.

Tighten lock nut (10) and check again clearance.

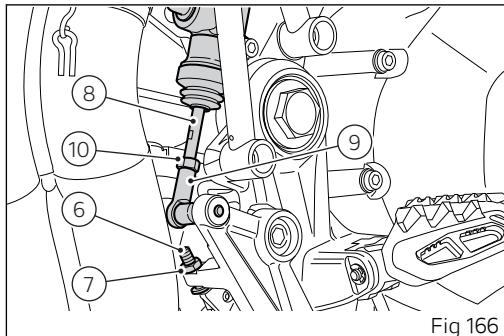

# Main components and devices

## Position on the vehicle

- 1) Tank filler plug.
- 2) Seat lock.
- 3) Side stand.
- 4) Rear-view mirrors.
- 5) Rear shock absorber adjusters.
- 6) Catalytic converter.
- 7) Exhaust silencer.

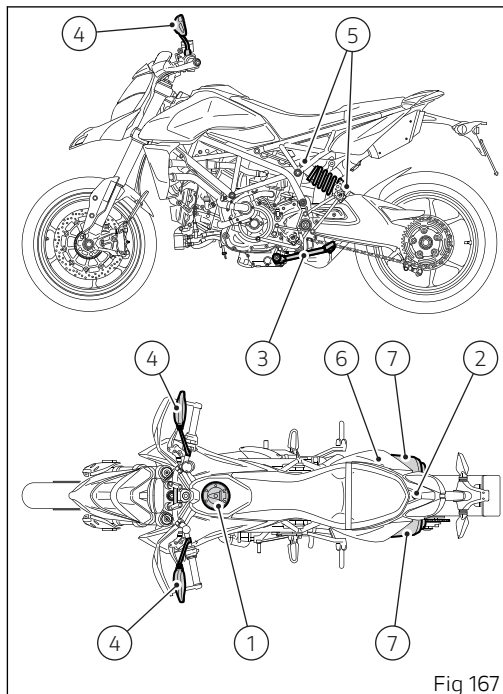

Fig 167

## Tank filler plug

### OPENING

Lift flap (1) and insert the key in the lock. Turn the key clockwise by 1/4 of a turn to release the lock.

### CLOSING

Close the plug with key inserted and press to fit in place. Turn the key counter clockwise to the original position and remove it. Close flap (1).



### Note

Plug can only be closed when key is inserted.



### Attention

After refuelling, always make sure that the plug is perfectly in place and closed.

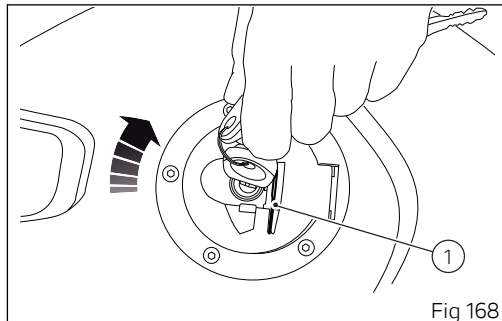

Fig 168

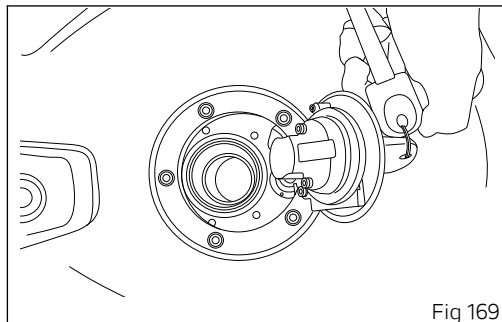

Fig 169

## Seat lock

### Removal procedure

Using wrench (1) on radiator RH side, loosen screw (2) retaining seat to tail guard.

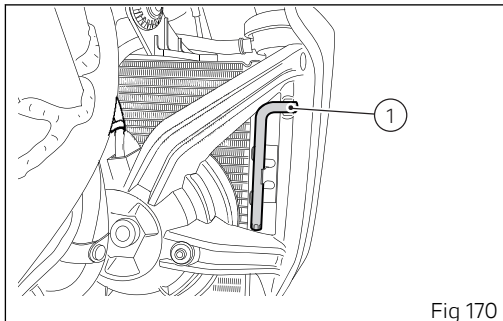

Fig 170

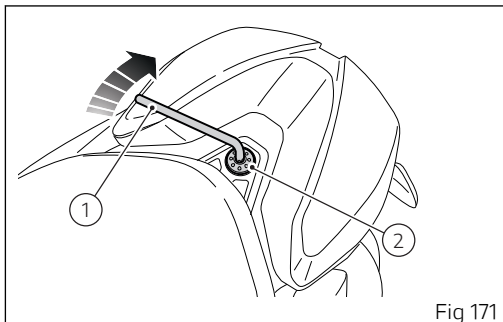
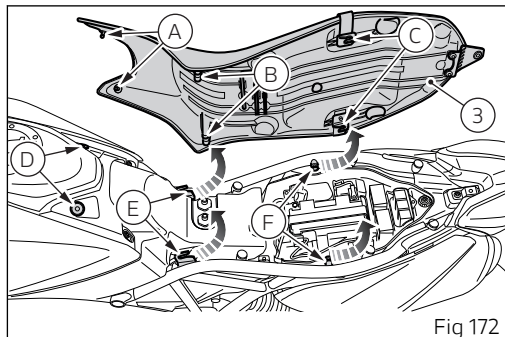

Fig 171

Remove the seat (3), sliding it at the back and up to disengage retainers (A), (B) and (C) from their seats (D), (E) and (F) on the vehicle.



## Refitting

Working in the opposite direction, fit the seat (3) to the vehicle, and make sure to engage retainers (B) and (C) in their seats (E) and (F); then press reference pins (A) into their seats (D).

Tighten screw (2) using wrench (1) supplied and set wrench back to its housing, on radiator RH side.

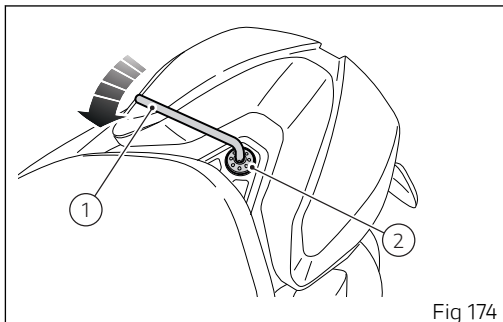
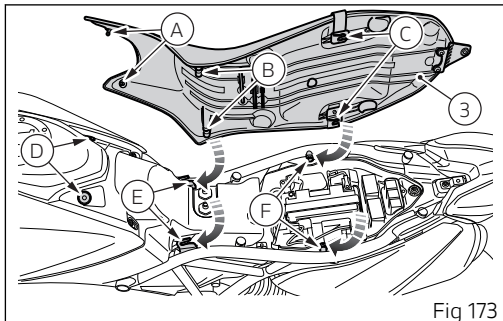

## Side stand

### Important

Place the motorcycle on the side stand only when you are not going to use it for short periods of time. Before lowering the side stand, make sure that the bearing surface is hard and flat.

Do not park on soft or pebbled ground or on asphalt melted by the sun, etc. or else the motorcycle may fall over. When parking downhill, always position the motorcycle with the rear wheel facing downhill.

To pull down the side stand, hold the motorcycle handlebars with both hands and push down on the side stand (1) with your foot until it is fully extended. Tilt the motorcycle until the side stand is resting on the ground.

To move the side stand to its "resting" position (horizontal position), lean the motorcycle to the right while lifting the thrust arm (1) with your foot.

To ensure trouble-free operation of the side stand joint, thoroughly clean it and then use SHELL Alvania R3 grease to lubricate all friction points.

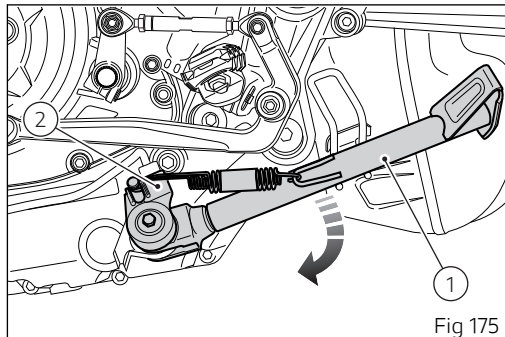

### Attention

Do not sit on the motorcycle when it is supported on the side stand.

### Note

Check for proper operation of the stand mechanism (two springs, one into the other) and the safety sensor (2) at regular intervals.

## Front fork adjustment

The front fork used on this motorcycle has rebound (return), compression and spring preload adjustment.

It is possible to adjust the spring preload on both legs whereas compression and rebound can only be adjusted on the LH and RH legs, respectively.

Adjustment is done by external screw adjusters:

- 1) for rebound adjustment;
- 2) to adjust the preload of the inner springs;
- 3) to adjust the compression damping.

Position the motorcycle on its side stand so that it is stable. Turn the adjuster (1) at the top end of the RH fork leg with a suitable screwdriver to adjust rebound damping. Turn adjuster (3) at the top end of the LH fork leg with a screwdriver to adjust compression. By turning adjuster screws (1) and (3) you will hear some clicks; each click corresponds to a damping setting.

The stiffest damping setting is obtained with the adjuster turned fully clockwise to the "0" position. By turning counter clockwise starting from this position, count the clicks that will correspond to positions "1", "2" etc.

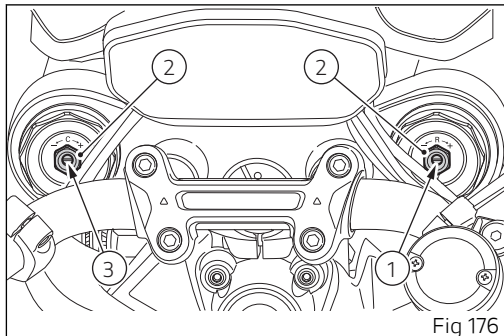

STANDARD settings are as follows:

- compression on LH fork leg: - 2 turns from fully closed (total is 4 full turns);
- rebound on RH fork leg: - 2.5 turns from fully closed (total is 4 full turns);
- spring preload: + 5 turns from fully uncompressed (1mm (0.04in) preload for each complete turn clockwise from the reference; for a total of 10mm (0.4 in)).

To change preload of the spring inside each fork leg, turn adjuster (2) with a 17 mm (0.67 in) hexagon



wrench, completely counter clockwise, to obtain fully uncompressed position. From this position, adjust the spring preload by turning the adjuster clockwise. Every turn corresponds to 1 mm (0.04 in) of spring preload.



### **Attention**

Adjust both fork legs to same settings.

## Adjusting the rear shock absorber

The rear shock absorber has adjusters that enable you to suit the setting to the load on the motorcycle. Adjuster (1) adjusts the damping during the rebound phase (return).

Turn adjuster (1) clockwise to stiffen the damping, or counter clockwise to soften it.

The two ring nuts (2), located in the shock absorber upper side, adjust the external spring preload. To change spring preload, slacken the upper locking ring nut.

Then **TIGHTEN** or **SLACKEN** the lower ring nut to **INCREASE** or **DECREASE** spring preload.

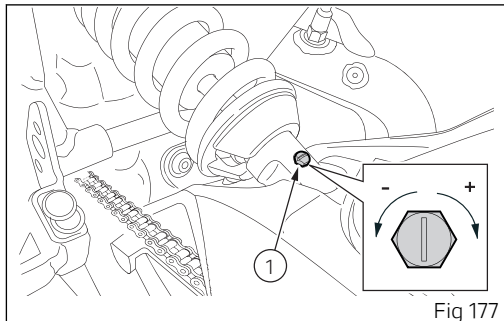

Fig 177

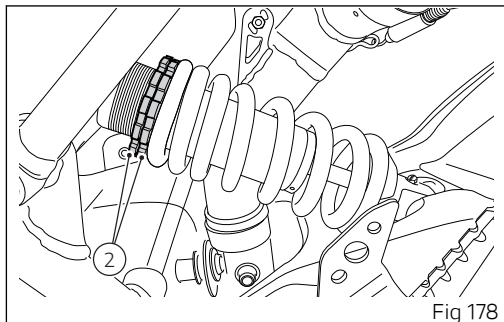

Fig 178

STANDARD setting, spring preload corresponding to value A, from the fully closed position (clockwise):

- rebound: loosen adjuster (1) by 1.5 turns from max. fully closed;
- spring preload: the maximum preload allowed corresponds to value B.

A =  $22 \pm 2$  mm (0.87  $\pm$  0.08 in);

B = 27 mm (1.06 in).

### Attention

Avoid a preload exceeding the one indicated not to affect the reliability of the part.

### Attention

Once the preload adjusted, re-tighten the locking ring nut against adjusting ring nut.

### Attention

To turn the preload adjuster ring nut use a pin wrench. Pay attention to avoid hand injuries by hitting motorcycle parts in case the wrench tooth suddenly slips on the ring nut groove while moving it.

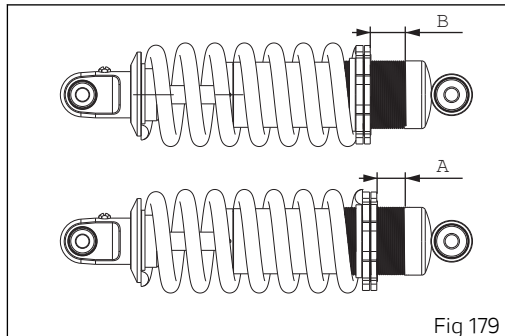

Fig 179

### Attention

The shock absorber is filled with gas under pressure and may cause severe damage if taken apart by unskilled persons.

When carrying a passenger and luggage, set the rear shock absorber spring to proper preload to improve motorcycle handling and keep safe clearance from the ground.

You may find that rebound damping needs adjusting as well.

# Riding the motorcycle

## Running-in recommendations

### Maximum rotation speed

Rotation speed for running-in period and during standard use (rpm):

- 1) Up to 1,000 km (600 mi);
- 2) From 1000 km (600 mi) to 2500 km (1500 mi).

Up to 1,000 Km (600 mi)

During the first 600 mi (1000 km) keep an eye on the rev counter, it should never exceed: 5,500÷6,000 rpm.

During the first hours of riding, it is advisable to run the engine at varying load and rpm, though still within recommended limit.

To this end, roads with plenty of bends and even slightly hilly areas are ideal for a most efficient running-in of engine, brakes and suspensions.

For the first 100 km use the brakes gently. Avoid sudden or prolonged braking. This will allow the

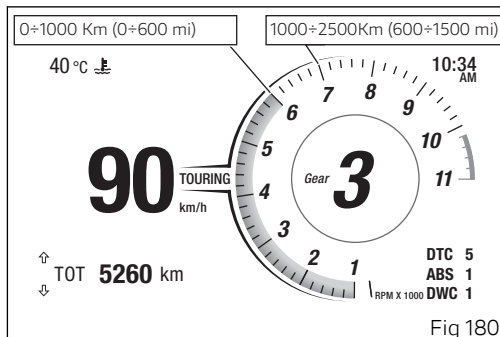

friction material on the brake pads to bed in against the brake discs.

For all mechanical parts of the motorcycle to adapt to one another and above all not to adversely affect the life of basic engine parts, it is advisable to avoid harsh accelerations and not to run the engine at high rpm for too long, especially uphill.

Furthermore, the drive chain should be inspected frequently. Lubricate as required.

From 1000 km (600 mi) to 2500 km (1500 mi).

From 1,000 km (600 mi) to 2,500 km (1,500 mi) you can squeeze some more power out of your engine. However never exceed 7,000 rpm.



### **Important**

During the whole running-in period, the maintenance and service rules recommended in the Warranty Card should be observed carefully. Failure to follow these instructions releases Ducati Motor Holding S.p.A. from any liability whatsoever for any engine damage or shorter engine life.

Strict observance of running-in recommendations will ensure longer engine life and reduce the likelihood of overhauls and tune-ups.

## Pre-ride checks



### Attention

Failure to carry out these checks before riding, may lead to motorcycle damage and injury to rider and passenger.

Before riding, perform a thorough check-up on your motorcycle as follows:

- **FUEL LEVEL IN THE TANK**  
Check the fuel level in the tank. Refuel if necessary (see "Refuelling").
- **ENGINE OIL LEVEL**  
Check oil level in the sump through the sight glass. Top up if necessary (see "Engine oil level check").
- **BRAKE AND CLUTCH FLUID**  
Check liquid level in the corresponding reservoirs (see "Checking brake and clutch fluid level").
- **COOLANT**  
Check the level of coolant in the expansion reservoir; top up if necessary (see "Checking and topping up the coolant level").
- **TYRE CONDITION**  
Check tyre pressure and condition (see "Tubeless tyres").
- **CONTROLS**  
Work the brake, clutch, throttle and gear change controls (levers, pedals and twistgrip) and check for proper operation.
- **LIGHTS AND INDICATORS**  
Make sure lights, indicators and horn work properly. Replace any burnt-out bulbs (see "Replacing headlight light bulbs").
- **KEY LOCKS**  
Check the tightening of the filler plug (see "Filler plug") and of the seat (see "Seat lock").
- **STAND**  
Make sure side stand operates smoothly and is in the correct position (see "Side stand").

## ABS light

After Key-ON, the ABS light stays ON.  
When the motorcycle speed exceeds 5 km/h, the warning light switches OFF to indicate the correct operation of the ABS system.



### Attention

In case of malfunction, do not ride the motorcycle and contact a Ducati Dealer or authorised Service Centre.

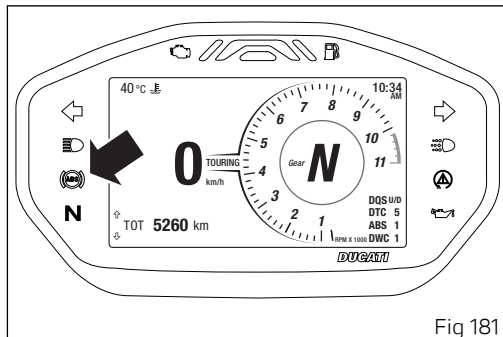

Fig 181

## ABS device

Check that the front (1) and rear (2) phonic wheels are clean.

### Attention

Clogged reading slots would compromise system proper operation. It is recommended to disable ABS system in case of muddy road surface because under this condition the system might be subject to sudden failure.

### Attention

Prolonged wheelies could deactivate the ABS system.

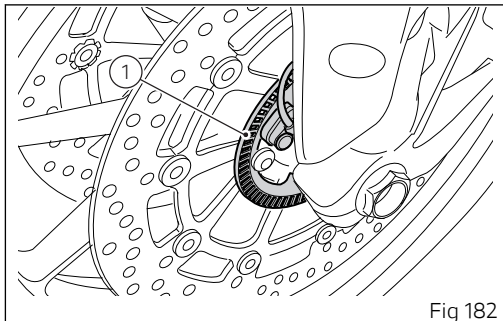

Fig 182

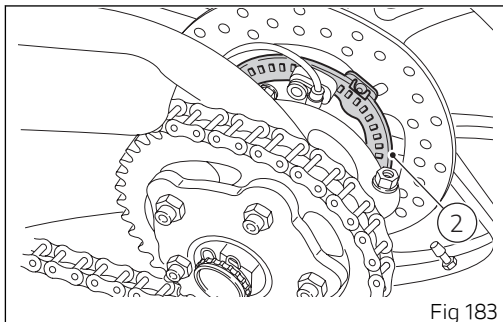

Fig 183



## Starting the engine

### Attention

Before starting the engine, become familiar with the controls you will need to use when riding.

### Attention

Never start or run the engine indoors. Exhaust gases are poisonous and may lead to loss of consciousness or even death within a short time.

Move the ignition switch to position (1). Make sure both the green light N (A) and the red light  (B) on the instrument panel come on.

### Important

The oil pressure light should go out a few seconds after the engine has started.

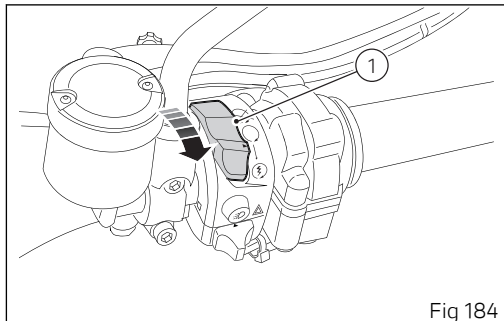

Fig 184

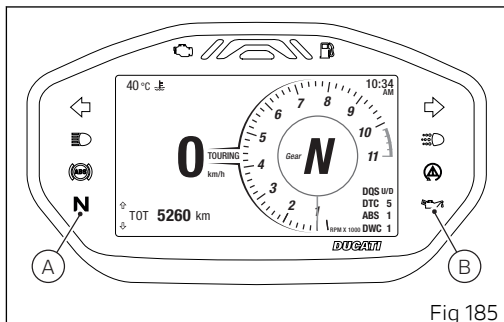



Fig 185

### Attention

The side stand must be fully up (in a horizontal position) as its safety sensor prevents engine starting when down.

### Note

It is possible to start the engine with side stand down and the gearbox in neutral. When starting the motorcycle with a gear engaged, pull the clutch lever (in this case the side stand must be up).

Make sure that emergency start/stop switch (2), is set to (A)  (RUN).

Press switch (2) to the bottom (B) and release it. Let the motorcycle start without operating the throttle control.

### Note

If the battery is flat, system automatically inhibits starter motor cranking operation.

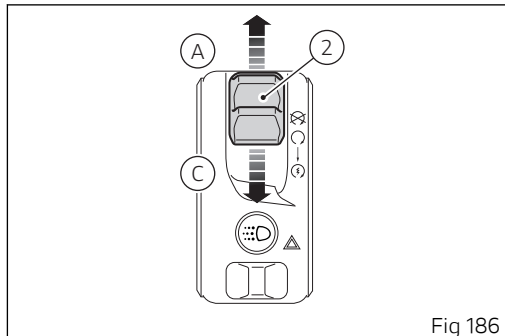

### Important

Do not rev up the engine when it is cold. Allow some time for oil to be heated and reach all points that need lubricating.

## Moving off

- 1) Squeeze the control lever to disengage the clutch.
- 2) Push down on gear change lever sharply with the tip of your foot to engage the first gear.
- 3) Speed up the engine by turning the throttle twistgrip while gradually releasing the clutch lever; the motorcycle will start moving off.
- 4) Let go of clutch lever and speed up.
- 5) To shift up, close the throttle to slow down engine, disengage the clutch, lift the gear change lever and let go of clutch lever.

To shift down, proceed as follows: release the twistgrip, pull the clutch lever, shortly speed up to help gears synchronise, shift down (engage next lower gear) and release the clutch.

The controls should be used correctly and timely: when riding uphill do not hesitate to shift down as soon as the motorcycle tends to slow down, so you will avoid stressing the engine and the motorcycle abnormally.



### Attention

Avoid harsh acceleration, as this may lead to misfiring and transmission snatching. The clutch lever should not be held in longer than necessary after a gear is engaged, otherwise friction parts may overheat and wear out.



### Attention

Prolonged wheelies could deactivate the ABS system.

## **Braking**

Slow down in time, shift down to use engine brake and then brake by operating both front and rear brakes. Pull the clutch before the motorcycle stops to avoid engine from suddenly stalling.

## **Anti-Lock Braking System (ABS)**

Using the brakes correctly under adverse conditions is the hardest – and yet the most critical – skill to master for a rider. Braking is one of the most difficult and dangerous moments when riding a two wheeled motorcycle: the possibility of falling or having an accident during this difficult moment is statistically higher than any other moment. A locked front wheel leads to loss of traction and stability, resulting in loss of control.

The Anti-Lock Brake System (ABS) has been developed to enable riders to use the motorcycle braking force to the fullest possible amount in emergency braking or under poor pavement or adverse weather conditions.

ABS uses hydraulics and electronics to limit pressure in the brake circuit when a special sensor mounted to the wheel informs the electronic control unit that the wheel is about to lock up.

This avoids wheel lockup and preserves traction. Pressure is raised back up immediately and the control unit keeps controlling the brake until the risk of a lockup disappears.

Normally, the rider will perceive ABS operation as a harder feel or a pulsation of the brake lever and pedal.

The front and rear brakes use separate control systems, meaning that they operate independently. Likewise, the ABS is not an integral braking system and does not control both the front and rear brake at the same time.



## Attention

When ABS is disabled, the motorcycle restores the standard brake system features; using the two brake controls separately reduces the motorcycle braking efficiency. Never use the brake controls harshly or suddenly as you may lock the wheels and lose control of the motorcycle. When riding in the rain or on slippery surfaces, braking will become less effective. Always use the brakes very gently and carefully when riding under these conditions. Any sudden manoeuvres may lead to loss of control. When tackling long, high-gradient downhill road tracts, shift down gears to use engine braking. Apply one brake at a time and use brakes sparingly. Keeping the brakes applied all the time would cause the friction material to overheat and reduce braking power dangerously. Underinflated tyres reduce braking efficiency, handling accuracy and stability in a bend.

## Stopping the motorcycle

Reduce speed, shift down and release the throttle twistgrip.

Shift down to engage first gear and then neutral.

Apply the brakes and bring the motorcycle to a complete stop.

To switch the engine off, simply turn the key to position (2).



### Important

Do not leave the key to ON, position (1), with engine off in order to avoid damaging any electrical components.

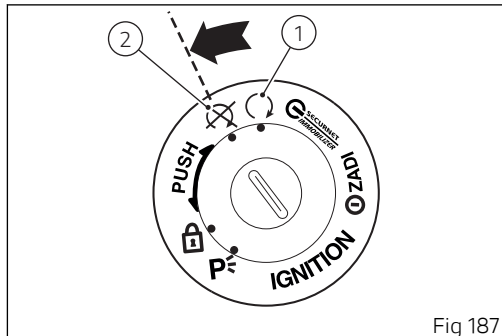

Fig 187

## Parking

Park the stopped motorcycle on the side stand. To prevent theft, turn the handlebar fully left and turn the ignition key to position (3). If you park in a garage or other indoor area, make sure that there is proper ventilation and that the motorcycle is not near a source of heat. You may leave the parking lights on by turning the key to position (4).

### Important

Do not leave the key to position (4) for a long time, or this could lead to battery discharge. Never leave the ignition key in the switch when you are leaving your motorcycle unattended.

### Attention

The exhaust system might be hot, even after engine is switched OFF; pay particular attention not to touch the exhaust system with any body part and do not park the motorcycle next to inflammable material (wood, leaves etc.).

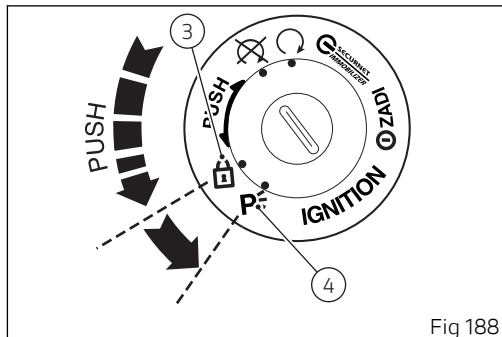

Fig 188

### Attention

Using padlocks or other locks designed to prevent motorcycle motion, such as brake disc locks, rear sprocket locks, and so on is dangerous and may impair motorcycle operation and affect the safety of rider and passenger.

## Refuelling

Never overfill the tank when refuelling. Fuel should never be touching the rim of filler recess (1).

### Warning

The fuel pressure inside the tank may, in extreme cases, cause fuel to "spray" when opening the fuel cap.

Always open the fuel cap slowly and carefully during the refill.

If you hear an audible hiss from the cap while opening it, wait until the stop of the hissing before opening it completely.

The sound is residual pressure escaping from the fuel tank, therefore the stop of the hiss indicates that there is no more residual pressure.

The situation described above is more likely in hot weather conditions.

### Attention

Use fuel with low lead content and an original octane number of at least 95.

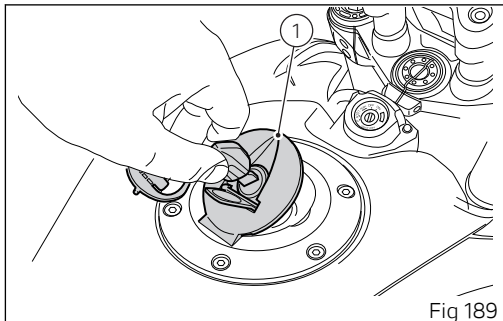

Fig 189

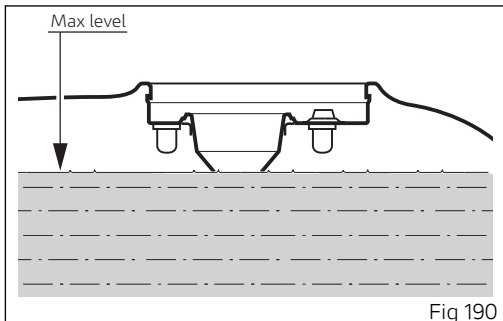

Fig 190





## Attention

The motorcycle is only compatible with fuel having a maximum content of ethanol of 10% (E10). Using fuel with ethanol content over 10% is forbidden. Using it could result in severe damage of the engine and motorcycle components. Using fuel with ethanol content over 10% will make the warranty null and void.

## Fuel label

The label in figure identifies the fuel recommended for this vehicle.

- 1) The E5 reference inside the label indicates the use of fuel with a maximum oxygen content of 2.7% by weight and a maximum ethanol content of 5% by volume, according to EN 228.
- 2) The E10 reference inside the label indicates the use of fuel with a maximum oxygen content of 3.7% by weight and a maximum ethanol content of 10% by volume, according to EN 228.

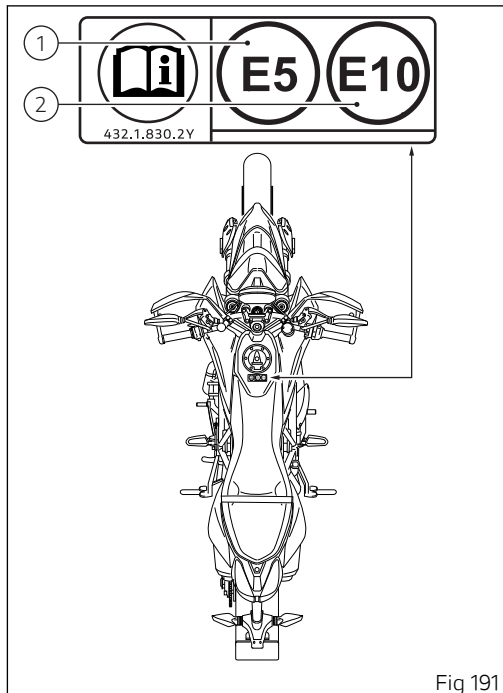

Fig 191

## Tool kit and accessories

Supplied accessories are laid out in the most convenient positions for their use.

Under the seat (1) you find:

- 3 mm Allen wrench (2);
- 5 mm Allen wrench (3);
- flat-blade/Phillips screwdriver (4).

To reach them, remove the seat page 211.

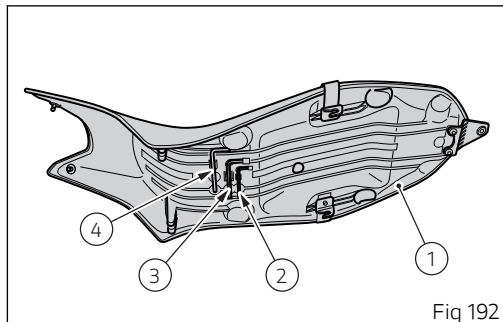

Fig 192

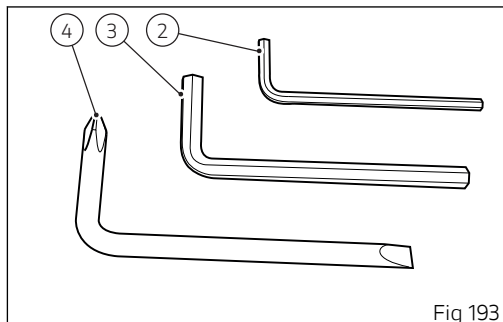

Fig 193

The fuse pliers (5) are fixed next to the fuse boxes.  
The Torx wrench (6) for removing the seat is fixed on  
vehicle RH side, close to radiator back side.

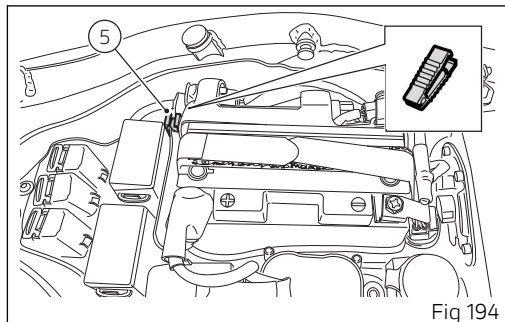

Fig 194

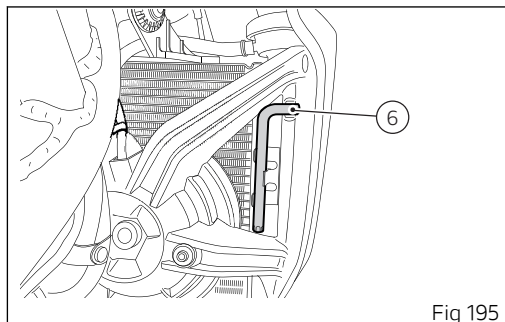

Fig 195

A socket wrench (7) 14x16x145 to remove the spark plugs tops off the tool kit.

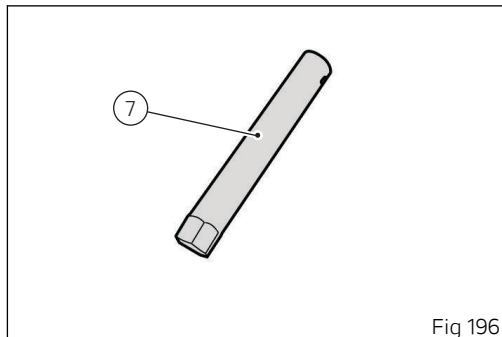

Fig 196

## Main use and maintenance operations

### Checking coolant level and topping up, if necessary

Check coolant level in the expansion tank on the right side of the steering tube. Steer completely to the left and check that the level is between the MIN and MAX marks on the side of the expansion reservoir. Top up if the level is below the MIN mark. Unscrew the filler plug (1) and add ENI Agip Permanent Spezial antifreeze (do not dilute, use pure), until reaching the MAX level. Screw plug (1) into seat. This type of mixture ensures the best operating conditions (the coolant starts to freeze at  $-20\text{ }^{\circ}\text{C}/-4\text{ }^{\circ}\text{F}$ ).

Cooling circuit capacity: 2.2 l (0.58 gal).

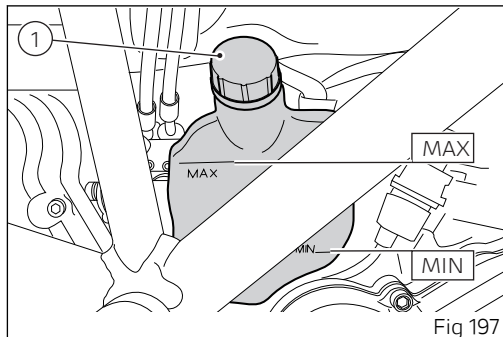

### Attention

This operation must be performed with cold engine. Failure to observe the above recommendation may lead to coolant or hot vapour leakage with possible consequent severe burns.

## Check clutch and brake fluid level

The levels should not fall below the MIN marks on the respective reservoirs.

If level drops below the limit, air might get into the circuit and affect the operation of the system involved.

Brake and clutch fluid must be topped up and changed at the intervals specified in the scheduled maintenance table contained in the Warranty Booklet; please contact a Ducati Dealer or Authorised Service Centre.

### CLUTCH SYSTEM

If the control lever has exceeding clearance and the transmission snatches or jams as you try to engage a gear, it means that there is air in the circuit. Contact your Ducati Dealer or Authorised Service Centre to have the system inspected and air drained out.

#### Attention

Clutch fluid level will increase as clutch plate friction material wears down. Do not exceed the specified level (3 mm - 0.12 in above the minimum level).

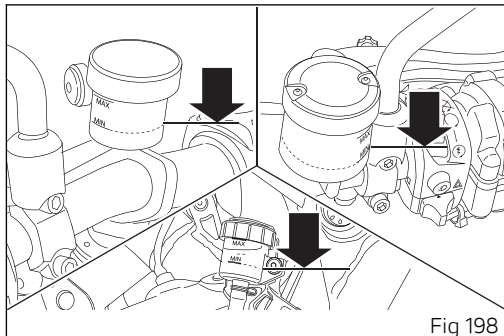

### BRAKE SYSTEM

If you find exceeding clearance on brake lever or pedal and brake pads are still in good condition, contact your Ducati Dealer or authorised Service Centre to have the system inspected and any air drained out of the circuit.



## Attention

Brake and clutch fluid can damage paintwork and plastic parts, so avoid contact. Hydraulic fluid is corrosive; it may cause damage and lead to severe injuries. Never mix fluids of different qualities. Check seals for proper sealing.



## Checking brake pads for wear

Check brake pads wear through the inspection hole in the callipers.

Change both pads if friction material thickness of even just one pad is about 1 mm.

### Attention

Friction material wear beyond this limit would lead to metal support contact with the brake disc thus compromising braking efficiency, disc integrity and rider safety.

### Important

Have the brake pads replaced at a Ducati Dealer or authorised Service Centre.

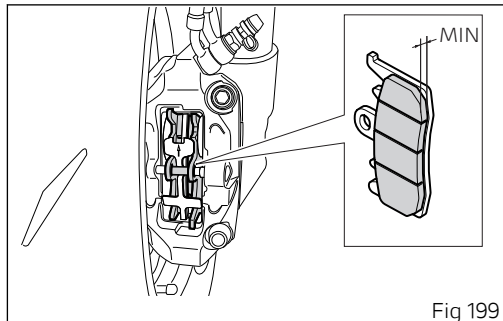

Fig 199

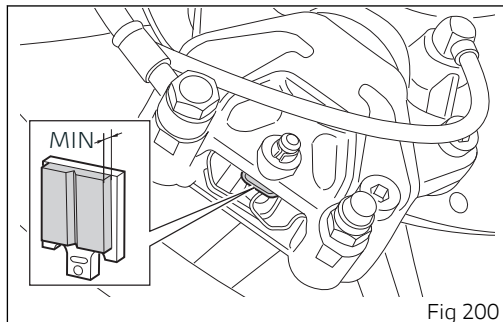

Fig 200

## Charging the battery



### Attention

Have the battery removed at a Ducati Dealer or authorised Service Centre.

To reach the battery it is necessary to remove the seat page 211. Loosen the screws (1), remove the positive cable (2) and (ABS) positive cable (3) from the positive terminal and the negative cable (4) from the negative terminal always starting from the negative one (-) and remove the battery by sliding it out of its housing.



### Attention

The battery gives off explosive gases; never cause sparks or allow naked flames and cigarettes near the battery. When charging the battery, ensure that the working area is properly ventilated.

Charge the battery in a ventilated room. Connect the battery charger leads to the battery terminals: the red one to the positive terminal (+), the black one to the negative terminal (-).

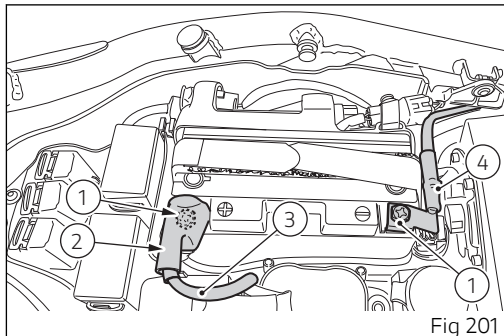

Fig 201



### Important

Make sure the charger is OFF when you connect the battery to it, or you might get sparks at the battery terminals that could ignite the gases inside the cells. Always connect the red positive (+) terminal first.

Grease the screws (1).

Refit the battery, connect the positive cable (2) and ABS positive cable (3) to the positive terminal and the negative cable (4) to the negative terminal of the battery, always starting from the positive (+), and fit the screws (1).



### **Attention**

Keep the battery out of the reach of children.

Charge the battery at 0.9 A for 5÷10 hours.

## Charging and maintenance of the battery during winter storage

Your motorcycle is equipped with a connector (1), under the seat, to which you can connect a special battery charger (2) (Battery maintenance kit part no. 69924601A - various countries; Battery maintainer kit part no. 69924601AX - for Japan, China and Australia only) available from our sales network.

### Note

The electric system of this model is designed so as to ensure there is a very low power drain when the motorcycle is OFF. Nevertheless, the battery features a certain self-discharge rate that is normal and depends on ambient conditions as well as on "non-use" time.

### Important

If battery is not kept at a minimum charge level by a suitable battery charge maintainer, sulphation may occur and this is an irreversible phenomenon causing decreasing battery performance.

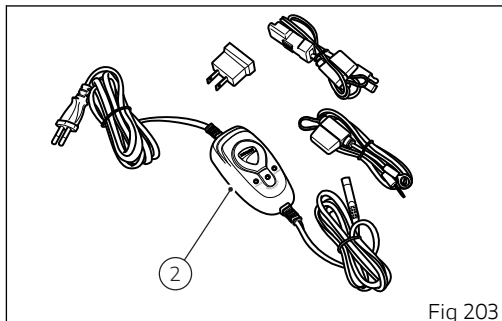
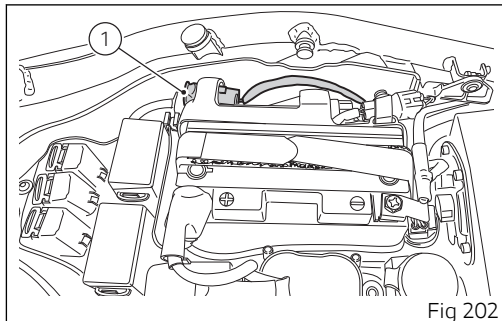

 **Note**

When the motorcycle is left unused (approximately for more than 30 days). We recommend owners to use the Ducati battery charge maintainer (Battery maintainer kit part no. 69924601A - various countries; Battery maintainer kit part no. 69924601AX - for Japan, China and Australia only) since its electronics monitors the battery voltage and features a maximum charge current of 1.5 Ah. Connect the maintainer to the diagnostics socket located in the rear side of the motorcycle.

 **Note**

Using charge maintainers not approved by Ducati could damage the electric system; motorcycle warranty does not cover the battery if damaged due to failure to comply with the above indications, since it is considered as wrong maintenance.

## Checking drive chain tension



### Important

Have chain tension adjusted by a Ducati Dealer or authorised Service Centre.

Make the rear wheel turn until you find the position where chain is tightest. Set the motorcycle on the side stand. With just a finger, push down the chain at the point of measurement and release. Measure the distance (A) between the centre of the chain pins and the aluminium section of the swinging arm. It must be:  $A = 65 \div 67$  mm (2.56÷2.64 in).



### Important

This only applies to the motorcycle STANDARD settings, available upon delivery.

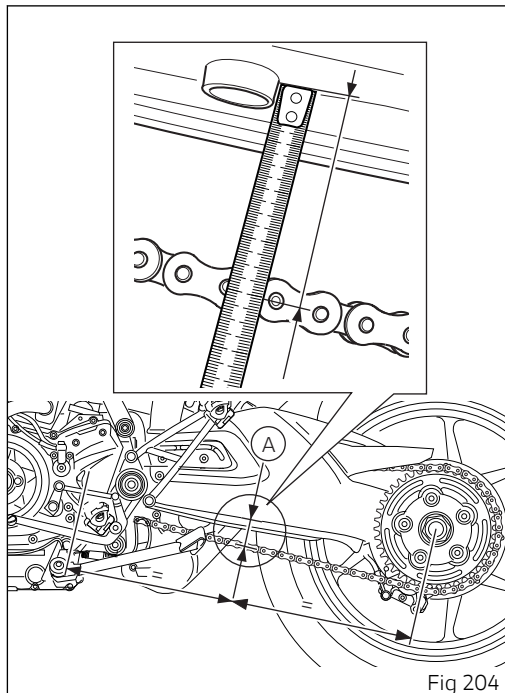

Fig 204

**⚠ Attention**  
Correct tightening of swinging arm screws (1) is critical to rider safety.

**⚠ Important**  
If drive chain is too tight or slack, adjust tension so as to bring values back to the specified range.

**⚠ Attention**  
Correct tightening of swinging arm screws (1) is critical to rider and passenger safety.

**⚠ Important**  
Improper chain tension will lead to early wear of transmission parts.

**⚠ Important**  
To ensure the best performance and long life of the chain, please follow the information related to chain cleaning, lubrication, inspection and tensioning.

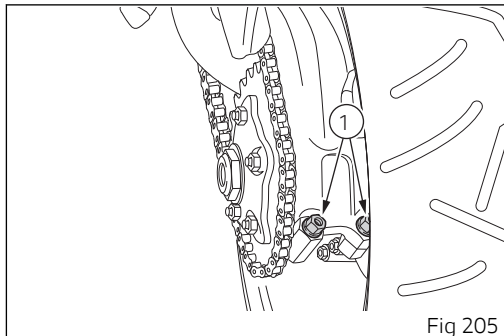

## Lubricating the drive chain



### **Important**

Have drive chain cleaned by a Ducati Dealer or authorised Service Centre.

### **Cleaning and lubricating the drive chain**

The chain fitted on your motorcycle has O-rings that keep dirt out of and lubricant inside the sliding parts. Before proceeding with the chain lubrication it is important to correctly wash and clean it.

The chain cleaning is extremely important for its duration. In fact, it is necessary to remove any mud, soil, sand or dirt from the chain using a jet of water and then dry it immediately using compressed air at a distance of at least 30 cm (11.81 in).





### Attention

Avoid the use of steam, fuel, solvents, hard brushes or other methods that could damage the O-rings; also avoid direct contact with the battery acid as it could cause mini cracks in the links as shown in the figure.



### Attention

In particular, in case of Off-Road use of the bike, it is possible that excessive wear of the links occurs due to the contact with the chain sliding shoe; friction could in fact cause the chain to overheat, altering the heat treatment of the links and making them particularly fragile.

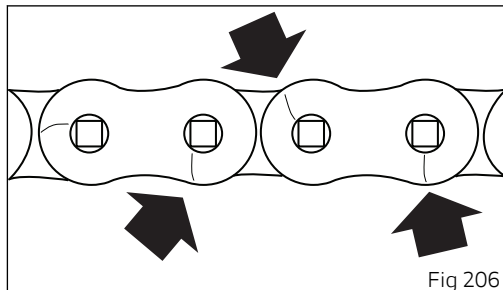

## Lubricating the drive chain



### Important

Have drive chain cleaned by a Ducati Dealer or authorised Service Centre.



### Attention

Use SHELL Advance Chain to lubricate the chain; the use of non-specific lubricants could damage the O-rings and therefore the entire drive system.

It is recommendable to lubricate the chain without waiting for it to cool down after using the motorcycle, so that the new lubricant can penetrate better between the inner and outer links and be more effective in its protective action.

Place the bike on the rear paddock stand. Make the rear wheel turns fast in the opposite direction to the direction of travel.

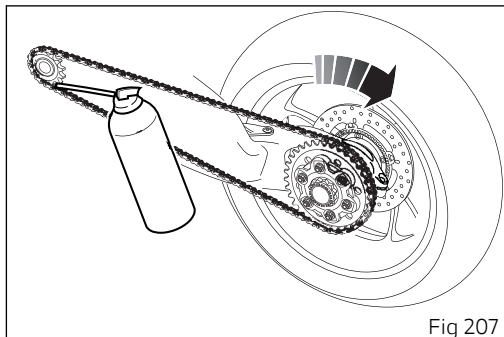

Apply the lubricant jet (1) inside the chain between the inner and outer links, in point (2) immediately before the engagement point on the sprocket.

Due to the centrifugal force, the lubricant, made fluid by the solvents contained in the spray, will expand in the working area between the pin and the bush, ensuring perfect lubrication.

Repeat the operation by aiming the lubricant jet to the central part (5) of the chain so as to lubricate the rollers (4), and to the outer plates (6) as shown in the figure.

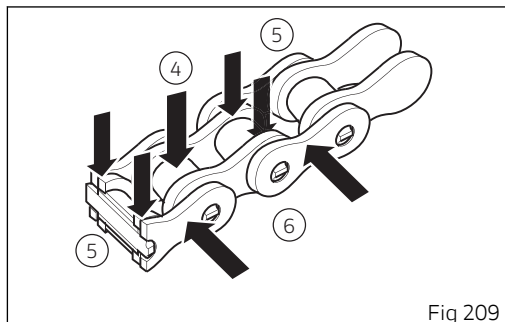
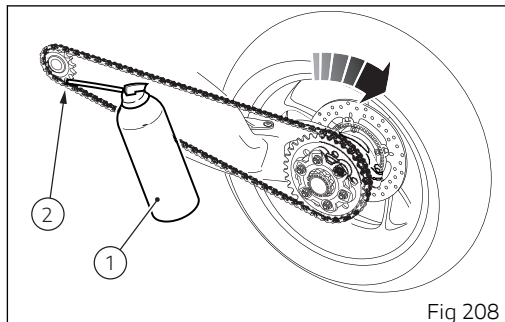

After lubrication, wait 10-15 minutes to allow the lubricant to act on the internal and external surfaces of the chain and then remove the excess lubricant with a clean cloth.

**⚠ Important**

Do not use the motorcycle immediately after lubricating the chain as the lubricant, still fluid, would be centrifuged outwards causing possible soiling of the rear tyre or the rider's footpeg.

**⚠ Important**

Check the chain often, taking care to lubricate it, as also indicated in the table below: at least every 1000 km (621 mi) or more frequently (about every 400 km (248 mi)) when using the bike with high outside temperatures (40°C) or after long travels on the highway at high speed.

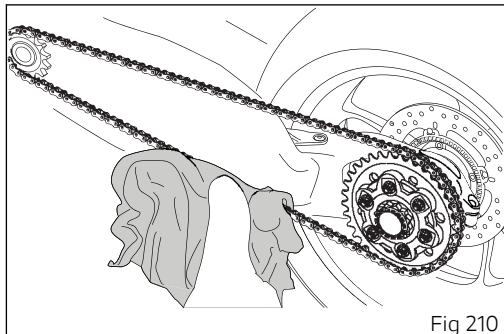

## Replacing the headlight bulbs



### Important

Have the lights replaced by a Ducati Dealer or an Authorised Service Centre.



### Attention

The headlight might fog up if the motorcycle is used under the rain or after washing. Switch headlight on for a short time to dry up any condensate.

Before replacing a burnt-out bulb, make sure that the new one matches the voltage and wattage specifications in paragraph "Electric System" page 285. Always check that the bulb functions before reassembling removed parts. Loosen the screws (1). Slightly lift the headlight support.

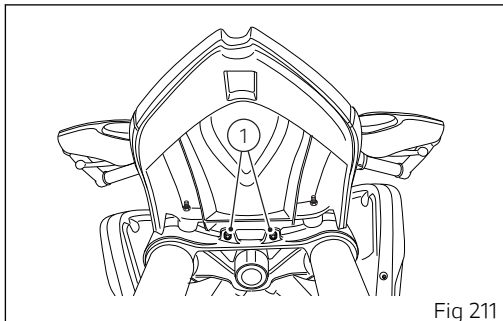

Fig 211

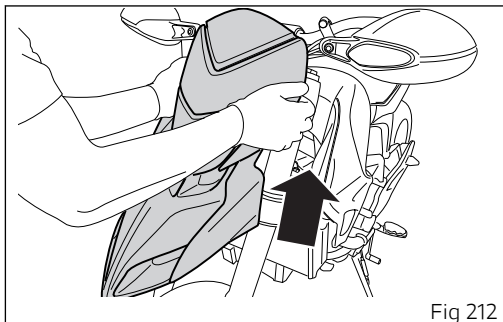
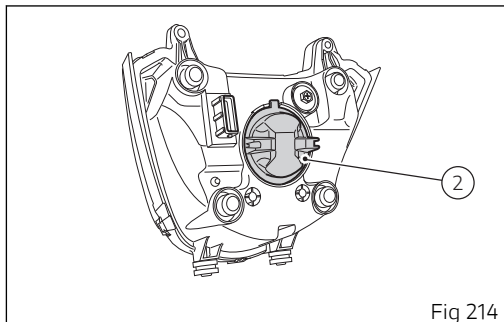
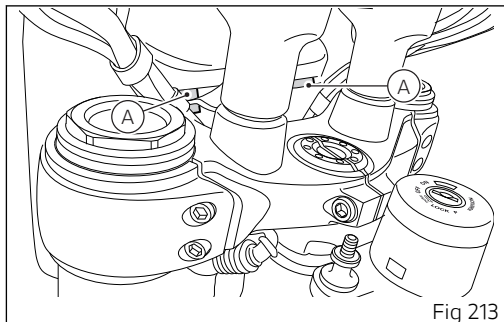

Fig 212

Slide headlight support out of rubber blocks (A).  
Slide headlight support toward bike front end until  
cover (2) is in view.  
Loosen cover (2) counter clockwise.



Disconnect the connector.

Release the clip (4).

The bulb (5) has a bayonet joint: press and twist counter clockwise to remove it. Remove the bulb, then fit the new one by pressing and turning clockwise until it clicks into its seat.

### Note

Be careful to hold the new bulb at the base only. Never touch the transparent body with your fingers or it will blacken resulting in reduced bulb brilliancy.

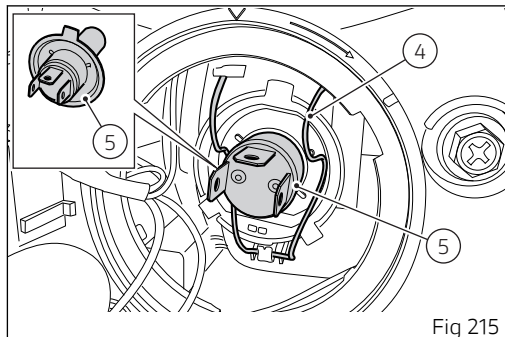

## Changing the turn indicator bulbs

### Front turn indicators

The front turn indicators are built in the hand guards (1) and are maintenance-free as they are LED type. To reach it, remove the four screws (2) and remove the cover (3).



### Important

Have the bulbs changed at a Ducati Dealer or authorised Service Centre.

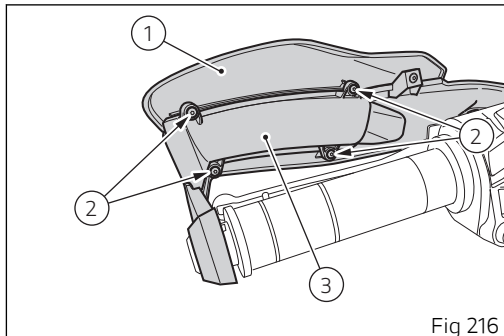



## Rear turn indicators

Except for USA/CDN version, turn indicators are LED-type and do not require any maintenance.

USA/CDN versions are equipped with bulb-type turn indicators.

Proceed as specified in case it is necessary to change the bulbs.

Undo the screw (4) and detach the lens (5) from the turn indicator support.

The bulb has a bayonet joint: press and twist counter clockwise to remove it.

Remove the bulb, then fit the new one by pressing and turning clockwise until it clicks into its seat.

Refit the lens (5) by inserting the tab in the corresponding slot in the turn indicator support.

Tighten the screw (4).

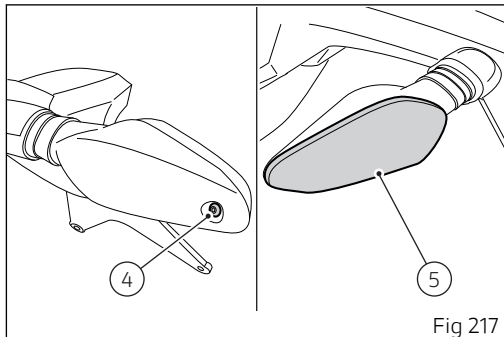

## Number plate light

The LED number plate light is maintenance-free.



### **Important**

Have the bulbs changed at a Ducati Dealer or authorised Service Centre.

## Aligning the headlight

### Note

Headlight features two adjusters, one for the RH beam and one for the LH beam.

Check correct headlight aiming. Position the motorcycle 10 m (32.8 ft) from a wall or a screen, the motorcycle must be perfectly upright with the Tyres inflated to the correct pressure and with a rider seated, perfectly perpendicular to the longitudinal axis. On the wall or surface, draw a horizontal line at the same height from the ground as the centre of the headlight and a vertical line aligned with the longitudinal axis of the motorcycle. If possible, perform this check in dim light. Switch on the low beam and adjust right and left beams. The height of the upper limit between the dark area and the lit area must not be more than  $\frac{9}{10}$  of the height from the ground of the headlight centre.

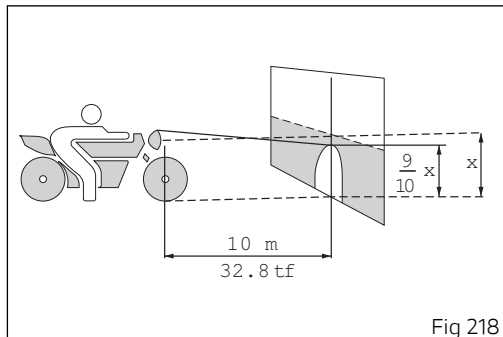

Fig 218

### Note

This is the procedure specified by Italian regulations for checking the maximum height of the light beam. Please adapt said procedure to the provisions in force in your own country.

## Aligning the headlight

Turn the screw (1) to set beam height.

Turn screw (1) clockwise to move beam up.

Turn screw (1) counter clockwise to move beam down.

### **Important**

Headlight beam adjuster screws have no limit stop.

### **Attention**

The headlight might fog up if the motorcycle is used under the rain or after washing. Switch headlight on for a short time to dry up any condensate.

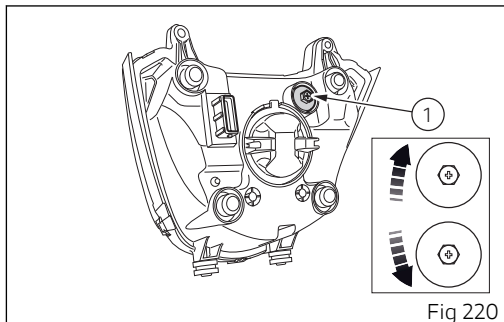
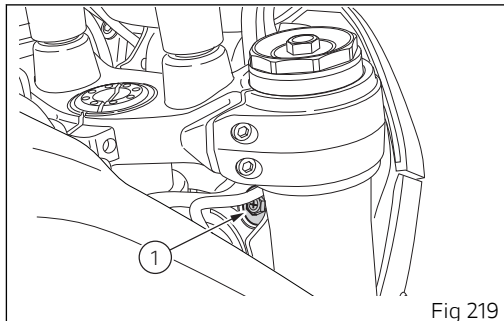

## Adjusting the rear-view mirrors

Manually adjust rear-view mirror (A) to required position.

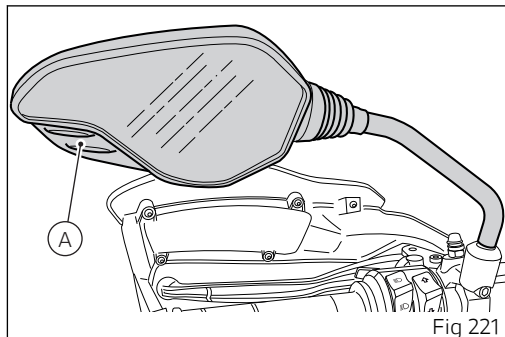

## Tubeless tyres

Front tyre pressure:

2.50 bar (rider only) - 2.50 bar (full load).

Rear tyre pressure:

2.50 bar (rider only) - 2.90 bar (full load).

As tyre pressure is affected by ambient temperature and altitude variations, you are advised to check and adjust it whenever you are riding in areas where ample variations in temperature or altitude occur.

### Important

Check and set tyre pressure when tyres are cold. To avoid front wheel rim distortion, when riding on bumpy roads, increase tyre pressure by 0.2 ÷ 0.3 bar.

### Tyre repair or change (Tubeless tyres)

In the event of a tiny puncture, tubeless tyres will take a long time to deflate, as they tend to keep air inside. If you find low pressure on one tyre, check the tyre for punctures.

### Attention

Punctured tyres must be replaced. Replace tyres with recommended standard tyres only. Be sure to tighten the valve caps securely to avoid leaks when riding. Never use tube type tyres. Failure to heed this warning may lead to sudden tyre bursting and to serious danger to rider and passenger.

After replacing a tyre, the wheel must be balanced.

### Attention

Do not remove or shift the wheel balancing weights.

### Note

Have the tyres replaced at a Ducati Dealer or authorised Service Centre. Correct removal and installation of the wheels is essential. Some parts of the ABS (such as sensors and phonic wheels) are mounted to the wheels and require specific adjustment.

## Minimum tread depth

Measure tread depth (S, Fig 222) at the point where tread is most worn down: it should not be less than 2 mm, and in any case not less than the legal limit.



### Important

Visually inspect the tyres at regular intervals for detecting cracks and cuts, especially on the side walls, bulges or large spots that are indicative of internal damage. Replace them if badly damaged. Remove any stones or other foreign bodies caught in the tread.

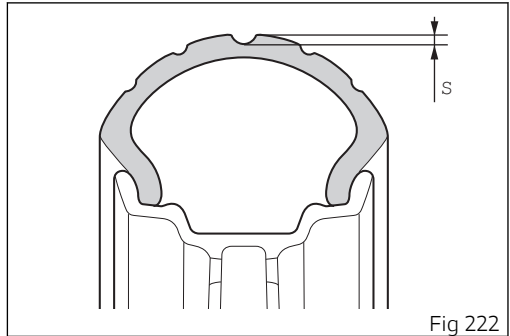

Fig 222

## Check engine oil level

Check the engine oil level through the sight glass (1) on the clutch cover.

Oil level should be between the marks on the sight glass. If the level is low, top up with engine oil.

Ducati recommends you use Shell Advance 4T Ultra 15W-50 oil (JASO: MA2 and API: SN).

Remove the oil filler cap (2) and top up until the oil reaches the required level. Refit the plug.

### Important

Engine oil and oil filters must be changed by a Ducati Dealer or authorised Service Centre at the intervals specified in the scheduled maintenance chart reported in the Warranty Card.

To check the oil level correctly, carefully follow the instructions below.

1) The level must be checked with warm engine, so if it is not performed after riding for at least 20/30 minutes you will need to warm up the engine.

If, on the other hand, the engine is cold, start it and let it warm up until the cooler fans start two consecutive times (the engine oil must be perfectly

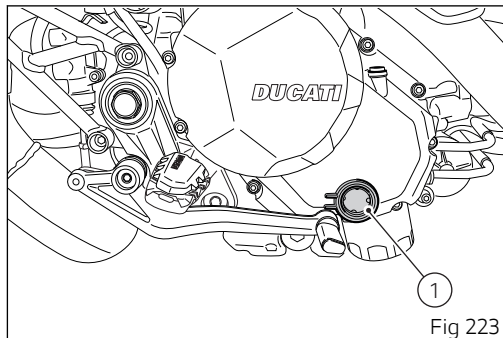

Fig 223

warm to flow along the lines and reach the engine sump).

During this warming up phase, the bike can be left on the side stand.

2) Turn off the engine and wait 10\15 minutes to allow the oil to flow completely inside the sump.

3) Position the bike with both wheels on a flat ground and in straight position.

4) Then, check the engine oil through the sight glass.

5) If the oil level is below the middle line between the MIN and MAX marks, add oil until reaching the maximum level indication.





## Attention

Never exceed the MAX mark.

## Recommendations concerning oil

It is recommended to use oil complying with the following specifications:

- viscosity grade SAE 15W-50;
- standard API: SN;
- standard JASO: MA2.

SAE 15W-50 is an alphanumeric code identifying oil class based on viscosity: two figures with a W ("winter") in-between; the first figure indicates oil viscosity at low temperature; the second figure indicates its viscosity at high temperature. API (American standard) and JASO (Japanese standard) standards specify oil characteristics.

## Cleaning and replacing the spark plugs

Spark plugs are essential to smooth engine running and should be checked at regular intervals. Have the spark plug replaced by a Ducati Dealer or an authorised Service Centre.

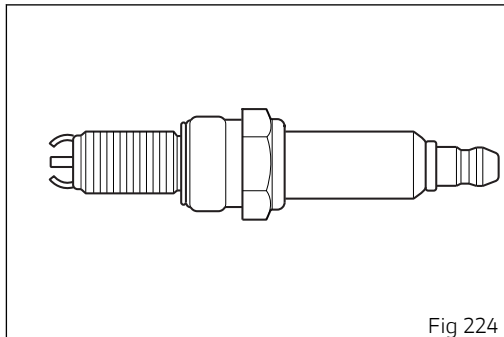

Fig 224

## Cleaning the motorcycle

To preserve the finish of metal parts and paintwork, wash and clean your motorcycle at regular intervals, anyway according to road conditions. Use specific products only. Prefer biodegradable products. Avoid aggressive detergents or solvents.

Use only water and neutral soap to clean the Plexiglas and the seat.

Periodically clean by hand all aluminium components. Use special detergents, suitable for aluminium parts. Do NOT use abrasive detergents or caustic soda.



### Note

Do not use sponges with abrasive parts or steel wool: only use soft cloths.

However, the warranty does not apply to motorcycles whenever poor maintenance status is ascertained.



### Important

Do not wash your motorcycle right after use. When the motorcycle is still hot, water drops will evaporate faster and spot hot surfaces.

Never clean the motorcycle using hot or high-pressure water jets.

Cleaning the motorcycle with a high pressure water jet may lead to seizure or serious faults in forks, wheel hubs, electric system, headlight (fogging), fork seals, air inlets or exhaust silencers, with consequent loss of compliance with the safety requirements.

Clean off stubborn dirt or exceeding grease from engine parts using a degreasing agent. Be sure to avoid contact with drive parts (chain, sprockets, etc.).

Rinse with warm water and dry all surfaces with chamois leather.



### Attention

Braking performance may be impaired immediately after washing the motorcycle. Never grease or lubricate the brake discs to avoid losing braking power. Clean the discs with an oil-free solvent.



### Attention

The headlight might fog up due to washing, rain or moisture. Switch headlight on for a short time to help and dry up any condensate.

Carefully clean the phonic wheels of the ABS in order to ensure system efficiency. Do not use aggressive products in order to avoid damaging the phonic wheels and the sensors.



### Attention

Avoid direct contact between instrument panel lens and oils/fuels that may stain or damage it thereby impairing information readability. To clean such parts, do not use alcohol-based detergents, containing solvent or abrasive agents; do not use sponges or cloths featuring hard or rough areas since they might scratch the surface.



### Note

Clean instrument panel lens using soft cloths with water and mild soap or detergents specific for cleaning clear plastic parts.



### Note

To clean the instrument panel do not use alcohol or its by-products.

Pay special attention when cleaning the wheel rims since they have parts in machined aluminium; clean and dry them every time you use the vehicle.



### Important

To clean and lubricate the drive chain, refer to the paragraph "Lubricating the drive chain".

## Storing the motorcycle

If the motorcycle is to be left unriden over long periods, it is advisable to carry out the following operations before storing it away:

- clean the motorcycle;
- empty the fuel tank;
- pour a few drops of engine oil into the cylinders through the spark plug seats, then crank the engine by hand a few times so a protective film of oil will spread on cylinder inner walls;
- place the motorcycle on a service stand;
- disconnect and remove the battery.

Battery should be checked and charged (or replaced, as required) whenever the motorcycle has been left unriden for over a month.

Protect the motorcycle with a suitable canvas. This will protect paintwork and let condensate breathe out.

The canvas is available from Ducati Performance.

### **Important notes**

Some countries, such as France, Germany, Great Britain, Switzerland, etc. have compulsory emission and noise standards that include mandatory inspections at regular intervals.

Periodically carry out the required checks and renew parts as necessary, using Ducati original spare parts, in compliance with the regulations in the country concerned.

# Scheduled maintenance chart

Scheduled maintenance chart: operations to be carried out by the dealer

List of operations and type of intervention [set mileage (km/mi) or time interval *]	Km. x1,000	1	15	30	45	60	Time (months)
	mi. x1,000	0.6	9	18	27	36	
Reading of the error memory with DDS and check of software version update on control units		•	•	•	•	•	12
Check the presence of any technical updates and recall campaigns		•	•	•	•	•	12
Change engine oil and filter		•	•	•	•	•	12
Clean the engine oil mesh filter assembly		•		•		•	-
Check and/or adjust valve clearance				•		•	-
Change timing belts				•		•	60
Change spark plugs				•		•	12
Clean air filter			•		•		-
Change air filter				•		•	-
Check brake and clutch fluid level		•	•	•	•	•	12
Change brake and clutch fluid							36

List of operations and type of intervention [set mileage (km/mi) or time interval *]	Km. x1,000	1	15	30	45	60	Time (months)
	mi. x1,000	0.6	9	18	27	36	
Check brake disk and pad wear. Change if necessary		●	●	●	●	●	12
Check the proper tightening of brake calliper bolts and brake disk flange screws		●	●	●	●	●	12
Check the proper tightening of the rear brake disc and phonic wheel			●	●	●	●	12
Check front and rear wheel nuts tightening		●	●	●	●	●	12
Check frame-to-engine fasteners tightening			●	●	●	●	-
Check wheel hub bearings				●		●	-
Check and lubricate the rear wheel shaft				●		●	-
Check the cush drive damper on rear sprocket				●		●	-
Check the proper tightening of final drive front and rear sprocket nuts		●	●	●	●	●	12
Check final drive (chain, front and rear sprocket) and sliding shoe wear			●	●	●	●	12
Check final drive chain tension and lubrication		●	●	●	●	●	12
Check steering bearings and lubricate, if necessary				●		●	-
Change front fork fluid					●		-



List of operations and type of intervention [set mileage (km/mi) or time interval *]	Km. x1,000	1	15	30	45	60	Time (months)
	mi. x1,000	0.6	9	18	27	36	
Visually check the front fork and rear shock absorber seals		•	•	•	•	•	12
Check the freedom of movement and tightening of the side and central stand (if any)		•	•	•	•	•	12
Visually check the fuel lines				•		•	-
Check rubbing points, clearance, freedom of movement and positioning of hoses and electric wiring in view		•	•	•	•	•	12
Lubricate the levers at the handlebar and pedal controls			•	•	•	•	12
Change coolant					•		48
Check the coolant level and check circuit for damage		•	•	•	•	•	12
Check tyre pressure and wear		•	•	•	•	•	12
Check the battery charge level		•	•	•	•	•	12
Check the operation of all electric safety devices (side stand sensor, front and rear brake switches, engine kill switch, gear/neutral sensor)		•	•	•	•	•	12
Check lighting, turn indicators, horn and controls		•	•	•	•	•	12
Reset the Service indication through the DDS 2.0		•	•	•	•	•	-

List of operations and type of intervention [set mileage (km/mi) or time interval *]	Km. x1,000	1	15	30	45	60	Time (months)
	mi. x1,000	0.6	9	18	27	36	
Final test and road test of the motorcycle, testing safety devices (ex. ABS and DTC), electric fans and idling		•	•	•	•	•	12
Softly clean the motorcycle		•	•	•	•	•	12
Fill out that the service was performed in on-board documentation (Service Booklet)		•	•	•	•	•	12

## Scheduled maintenance chart: operations to be carried out by the Customer



### Important

Using the motorcycle under extreme conditions, such as very damp and muddy roads or dusty and dry environment, could cause above-average wear of components like the drive system, the brakes or the air filter. If the air filter is dirty, the engine could get damaged. Therefore, this might translate in required service or replacement of the wear parts earlier than specified in the scheduled maintenance chart.

List of operations and type of intervention [set mileage (km/mi) or time interval *]	Km. x1000	1
	mi. x1,000	0.6
	Months	6
Check engine oil level		●
Check brake fluid level		●
Check tyre pressure and wear		●
Check the drive chain tension and lubrication		●
Check brake pads. If necessary, contact your dealer to replace pads		●

\* Service operation to be carried out in accordance with the specified distance or time intervals (km or months), whichever occurs first

# Technical data

## Weights

Overall weight (in running order with 90% of fuel - 44/2014/EU Annex XI): 200 kg (440.92 lb).

Dry weight: 178 kg (392.42 lb).

Maximum allowed weight (carrying full load): 375 kg (826.73 lb).



### **Attention**

Failure to observe weight limits could result in poor handling and impair the performance of your motorcycle, and you may lose control of the motorcycle.

## Dimensions

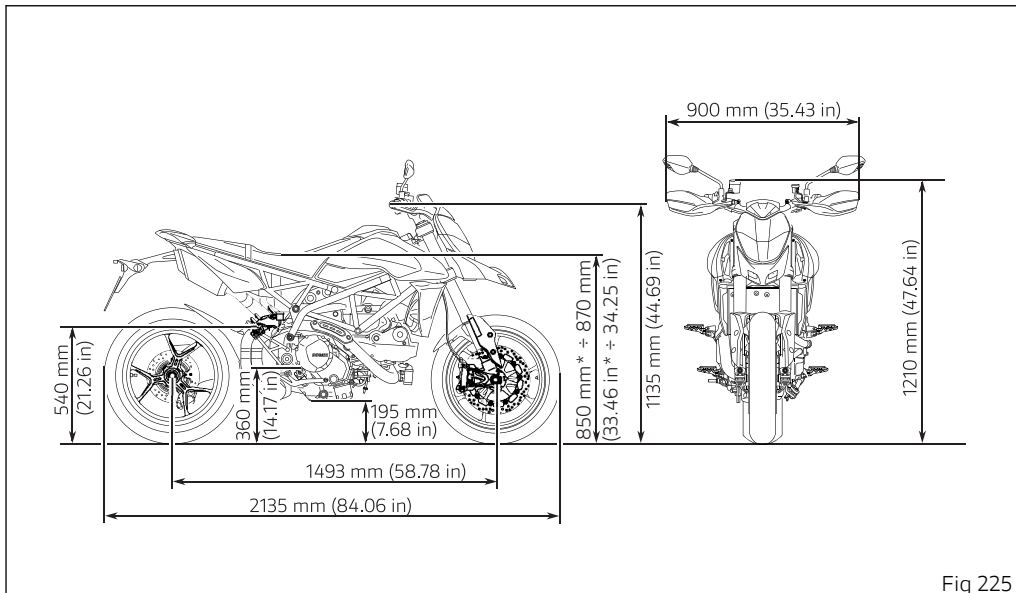

Fig 225

\* only for ROK and TWN versions.

## Fuel, lubricants and other fluids

TOP-UPS	TYPE	
Fuel tank, including a reserve of 3.5 litres (0.77 UK gal)	Ducati recommends SHELL V-Power unleaded premium fuel with a minimum of octane rating of RON 95	14.5 litres (3.19 UK gal)
Lubrication circuit	Ducati recommends you use SHELL Advance 4T Ultra 15W-50 oil (JASO: MA2, API: SN)	3.35 litres (0.74 UK gal)
Front/rear brake and clutch circuits	DOT 4	-
Protectant for electric contacts	Protective spray for electric systems	-
Front fork	SHELL Donax TA	145±2 cm <sup>3</sup> (5.59 in) (measured without spring and preload tube, with rod fully home)
Cooling circuit	ENI Agip Permanent Spezial antifreeze (do not dilute, use pure)	2.2 litres (0.48 UK gal)



### Important

Do not use any additives in fuel or lubricants. Using them could result in severe damage of the engine and motorcycle components.



### **Attention**

The motorcycle is only compatible with fuel having a maximum content of ethanol of 10% (E10). Using fuel with ethanol content over 10% is forbidden. Using it could result in severe damage of the engine and motorcycle components. Using fuel with ethanol content over 10% will make the warranty null and void.



### **Important**

These references indicate the fuel recommended for this vehicle as specified by the European regulation EN228.



## Engine

Desmodromic timing system with toothed belt, two overhead camshafts, 4 valves per cylinder and 8 rocker arms

Bore, mm: : 94 mm (3.7 in)

Stroke, mm: 67.5 mm (2.66 in)

Total displacement, cu. cm: 936.9 cu. cm (57.17 cu in)

Compression ratio: (13.3±0.5):1

Maximum power at crankshaft (EU) Regulation no. 134/2014, Annex X, kW/HP:  
84 kW/114.3 HP at 9000 rpm

Maximum torque at crankshaft (EU) Regulation no. 134/2014 Annex X:  
95.6 Nm - 9.8 kgm at 7250 rpm

Maximum rpm: 10200



## Note

The indicated power/torque values have been measured with a static test bench according to type-approval standards and match with the data detected during type-approval process; they are indicated in the vehicle registration document.



## Important

Do not exceed the specified rpm limits in any running conditions.



## Timing system

DESMODROMIC system with four valves per cylinder controlled by eight rocker arms and two overhead camshafts. This system is driven by the crankshaft through spur gears, belt rollers and toothed belts.

### Desmodromic timing system

- 1) Opening (or upper) rocker arm;
- 2) Upper rocker arm shim;
- 3) Closing (or lower) rocker arm shim;
- 4) Return spring for lower rocker arm;
- 5) Closing (or lower) rocker arm;
- 6) Camshaft;
- 7) Valve.

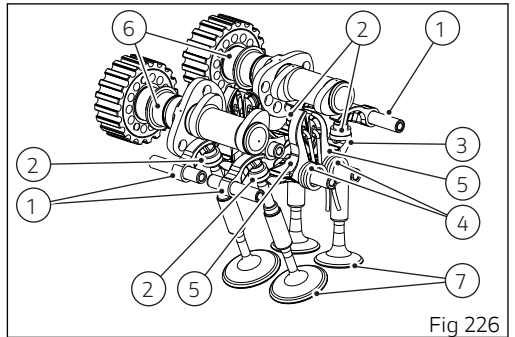

## Performance data

Maximum speed in any gear should be reached only after a correct running-in period with the motorcycle properly serviced at the recommended intervals.



## Important

Failure to follow these instructions releases Ducati Motor Holding S.p.A. from any liability whatsoever for any engine damage or shorter engine life.

## Spark plugs

Make:

NGK

Type:

MAR9A-J

## Fuel system

Continental indirect electronic injection.

Throttle body with full Ride by wire system, round cross-section having a diameter of 53 mm (2.09 in).

Injectors per cylinder: 1.

Firing points per injector: 4.

Fuel supply: 95-98 RON.



## Attention

The motorcycle is only compatible with fuel having a maximum content of ethanol of 10% (E10). Using fuel with ethanol content over 10% is forbidden. Using it could result in severe damage to the engine and motorcycle components. Using fuel with ethanol content over 10% will make the warranty null and void.

## Brakes

Separate-action anti-lock braking system operated by hall-type sensors mounted to each wheel with phonic wheel detection: ABS can be disabled.

### FRONT

Semi-floating 320 mm (12.6 in) twin-disc.

Braking material: stainless steel.

Hydraulically operated by an adjustable control lever on handlebar right-hand side.

Brake calliper make: BREMBO.

Type: M4.32 b.

Friction material: TT 2182 FF.

Calliper cylinder diameter: 32 mm (1.26 in).

Disc thickness: 4.5 mm (0.18 in).

Maximum wear on disc thickness: 4 mm (0.16 in).

Front brake master cylinder: PR18/19.

Cylinder Ø: 18 mm (0.71 in).

## REAR

With fixed drilled steel disc.

Disc diameter: 245 mm (9.65 in).

Disc thickness: 5 mm (0.2 in).

Maximum disc wear: 4.5 mm (0.18 in).

Hydraulically operated by a pedal on RH side.

Make: BREMBO

Type: P34e.

Friction material: Ferit I/D 450 FF.

Calliper cylinder diameter: 34 mm (1.34 in).

Cylinder Ø: 11 mm (0.43 in).

## Attention

The brake fluid used in the brake system is corrosive.

In the event of accidental contact with eyes or skin, wash the affected area with abundant running water.

## Transmission

Multiplate wet clutch controlled mechanically, by the lever on left-hand side of the handlebar. Self-servo and slipper mechanism.

Drive is transmitted from engine to gearbox primary shaft via spur gears.

Front chain sprocket/clutch gearwheel ratio: 33/61  
6-speed gearbox with constant mesh gears, gear change pedal on left side of motorcycle.

Gearbox output sprocket/rear chain sprocket ratio: 15/43

Total gear ratios:

1<sup>st</sup> gear 15/37

2<sup>nd</sup> gear 17/30

3<sup>rd</sup> gear 20/28

4<sup>th</sup> gear 22/26

5<sup>th</sup> gear 23/24

6<sup>th</sup> gear 24/23

Drive chain from gearbox to rear wheel.

Make: REGINA

Type: 520 ZRDK

Links: 106

## Important

The above gear ratios are the homologated ones and under no circumstances must they be modified.

However, if you wish to tune up your motorcycle for competitions or special tracks, Ducati Motor Holding

S.p.A. will be pleased to provide information about the special ratios available. Contact a Ducati Dealer or Authorised Service Centre.



### Attention

If the rear sprocket needs replacing, contact a Ducati Dealer or authorised Service Centre. If improperly replaced, this component could seriously endanger your safety, as well as the passenger one, and cause irreparable damage to your motorcycle.

### Frame

Steel tubular trellis with 34 mm main tubes.  
Steel rear subframe.  
Steering head angle: 25.5°.  
Steering angle: 35° LH side / 35° RH side.  
Trail: 104 mm (4.09 in).

### Wheels

Front

Light-alloy rims with 3 Y-shaped spokes.  
Size: MT3.50x17" M/C

Rear

Light-alloy rims with 3 Y-shaped spokes.

Size: MT5.50x17" M/C

Both wheel shafts can be removed.

### Tyres

Front

Pirelli Diablo Rosso III "tubeless" radial type.

Size:

120/70-ZR17 M/C (58W).

Rear

Pirelli Diablo Rosso III "tubeless" radial type.

Size:

180/55-ZR17 M/C (75W) TL (D).

### Suspension

Front

Marzocchi fully-adjustable hydraulic fork.

Stanchion diameter:

45 mm (1.77 in).

Wheel travel:

170 mm (6.69 in).

Rear

Sachs progressive shock absorber. The shock absorber is adjustable for rebound and spring preload. At the bottom pivot point it is connected to

a die-cast aluminium single-sided swinging arm. The whole system gives the motorcycle excellent stability.

Suspension travel:

61.5 mm (2.42 in).

Rear wheel travel:

150 mm (5.91 in).

## **Exhaust system**

2 into 1 into 2 exhaust system with aluminium tailpipes, catalytic converter and 2 lambda sensors.

## **Available colours**

DUCATI RED

Ducati Anniversary red code 473.101 (PPG);

Primer (White Acriflex) code L0040652 (LECHLER);

Varnish (Acriplast Red Stoner SF) code LMC06017 (LECHLER);

Mercury Grey subframe; product type Interpon A3000 Mineral Grey code MW/2/11375AVB (Akzo Nobel);

Red frame; product type Powder Coat TOA-PS P CA03- 90 RED code PU CA03-90 (TOA-PC).

Black wheel rims; including:

Primer Power Primer code P09809-C (Petere Lacke).

Top coat PEHADUR EINBRENNLACK code VPCH03250 (Petere Lacke).

## Electric system

Basic electric items are:

### Headlight

Low/High beam:

H4 blue vision bulb (12V – 60/55W).

Parking light:

10 LEDs Stanley H9J.

DRL lights (not available on China, Canada and Japan versions):

No. 10 LEDs Stanley H9J.

### Electrical controls on handlebar

Front turn indicators:

No. 12 LEDs Primax 150 Nazy-BHG-MN3-1.

Rear turn indicators:

(European version) No.1 LED Philips LXM2-PL01;

(USA version) 12V RY10W bulb.

Horn.

Stop light switches.

### Electrical components

Battery, 12V-10 Ah, dry.

Generator 14V - 490W - 35A.

Electronic rectifier, protected by a 30A fuse under the seat.

Starter motor:

12 V-0.7 kW.

### Tail light

Parking light:

No. 12 LEDs LAE6SF.

Stop light:

No. 12 LEDs LAE6SF.

Number plate light:

No. 3 LEDs CREE CLA1A.



### Note

For bulb replacement instructions, please see the paragraph "Replacing the high and low beam bulbs".

### Fuses

There are thirteen fuses that protect the electric components, located inside the front and rear fuse boxes, and one on the solenoid starter. There is a spare fuse in every box.

Refer to the table below to identify the circuits protected by the various fuses and their ratings.

The front fuse box (A) is located on the left side and can be reached by removing the front LH half-fairing. To expose the fuses, lift the box protective cover. Mounting position and ampere capacity are marked on box cover.

The rear fuse box (B) is located under the seat, next to the ABS control unit. To reach rear fuse box, remove the seat, see page 211. To expose the fuses, remove box protective cover. Mounting position and ampere capacity are marked on box cover.

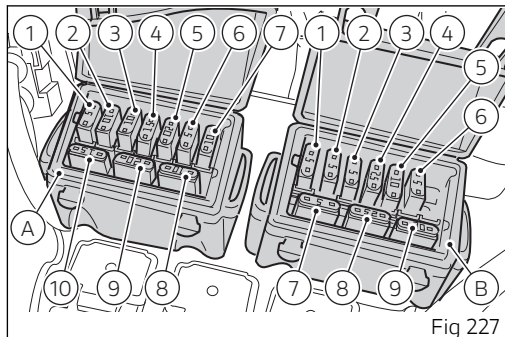

Fig 227

#### Front fuse box key (A)

Pos	El. item	Rat.
1	Lights	5 A
2	Instrument panel	10 A
3	Key-1	10 A
4	Key-2	15 A
5	El. loads	20 A
6	ECU	5 A
7	BBS	10 A
8	Spare	10 A
9	Spare	20 A

#### Front fuse box key (A)

10	Spare	15 A
----	-------	------

#### Rear fuse box key (B)

Pos	El. item	Rat.
1	Key-optional	5 A
2	Alarm	5 A
3	Stop	5 A
4	Diagnosis	7.5 A

<b>Rear fuse box key (B)</b>		
5	ABS Valve	10 A
6	ABS Motor	25 A
7	Spare	5 A
8	Spare	25 A
9	Spare	30 A



The main fuse (C) is located next to the rear fuse box, on solenoid starter (D). Remove the fuse cap (E) to reach it. A blown fuse can be identified by breakage of the inner filament (F).

**⚠ Important**  
Switch the ignition key to OFF before replacing the fuse to avoid possible short-circuits.

**⚠ Attention**  
Never use a fuse with a rating other than specified. Failure to observe this rule may damage the electric system or even cause fire.

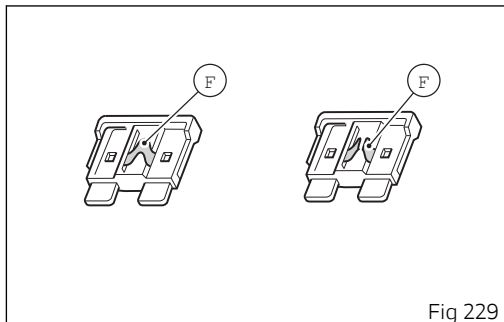
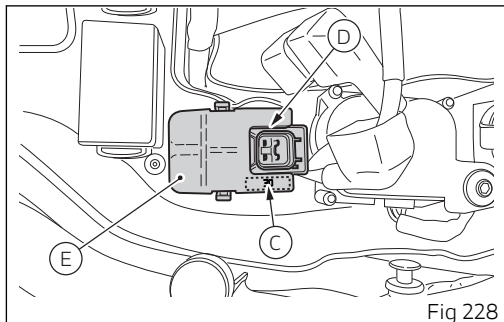

## Injection/electric system diagram key

- 1) Right-hand switch
- 2) Throttle twistgrip (Ride by wire)
- 3) LH fan
- 4) RH fan
- 5) Antenna
- 6) Ignition system (ignition switch)
- 7) Starter relay
- 8) ABS wiring
- 9) Wiring ground
- 10) Voltage regulator
- 11) Fuse box (2)
- 12) Fuse box (1)
- 13) ABS control unit
- 14) Front speed sensor
- 15) Rear speed sensor
- 16) Tail light
- 17) Bluetooth
- 18) USB socket
- 19) Rear right turn indicator
- 20) Rear left turn indicator
- 21) Number plate light
- 22) Diagnostic socket / data acquisition
- 23) Vehicle control unit (BBS)
- 24) Exhaust valve motor
- 25) Rear brake switch
- 26) Anti-theft system alarm
- 27) Fuel pump
- 28) Rpm sensor
- 29) Oil pressure sensor
- 30) Gear sensor
- 31) Ducati Quick Shift (DQS) (if available)
- 32) Air temperature sensor
- 33) Side stand switch
- 34) Vertical lambda sensor
- 35) Horizontal lambda sensor
- 36) MAP sensor
- 37) Engine temperature sensor
- 38) Purge valve
- 39) Secondary air actuator
- 40) Potentiometer motor / Ride by wire
- 41) Horizontal coil
- 42) Vertical coil
- 43) Vertical injector
- 44) Horizontal injector
- 45) Injector connector
- 46) Horn
- 47) Left-hand switch
- 48) Ambient air temperature
- 49) Front left turn indicator
- 50) LH heated handgrip

- 51) Clutch switch
- 52) Instrument panel
- 53) Front stop switch
- 54) RH heated handgrip
- 55) Front right turn indicator
- 56) Headlight
- 57) Starter relay
- 58) El. loads relay
- 59) Fuel pump relay
- 60) IMU control unit
- 61) ECU (connector B)
- 62) ECU (connector A)

### Wire colour coding

- B Blue
- W White
- V Violet
- Bk Black
- Y Yellow
- R Red
- Lb Light blue
- Gr Grey
- G Green
- Bn Brown
- O Orange

P Pink



### Note

The electric system wiring diagram is at the end of this manual.

# Routine maintenance record

## Routine maintenance record

KM	MI	NAME DUCATI SERVICE	DISTANCE IN KM	DATE
1000	600			
12000	7500			
24000	15000			
36000	22500			
48000	30000			
60000	37500			

Stampato 06/2019

Cod. 913.7.434.1A

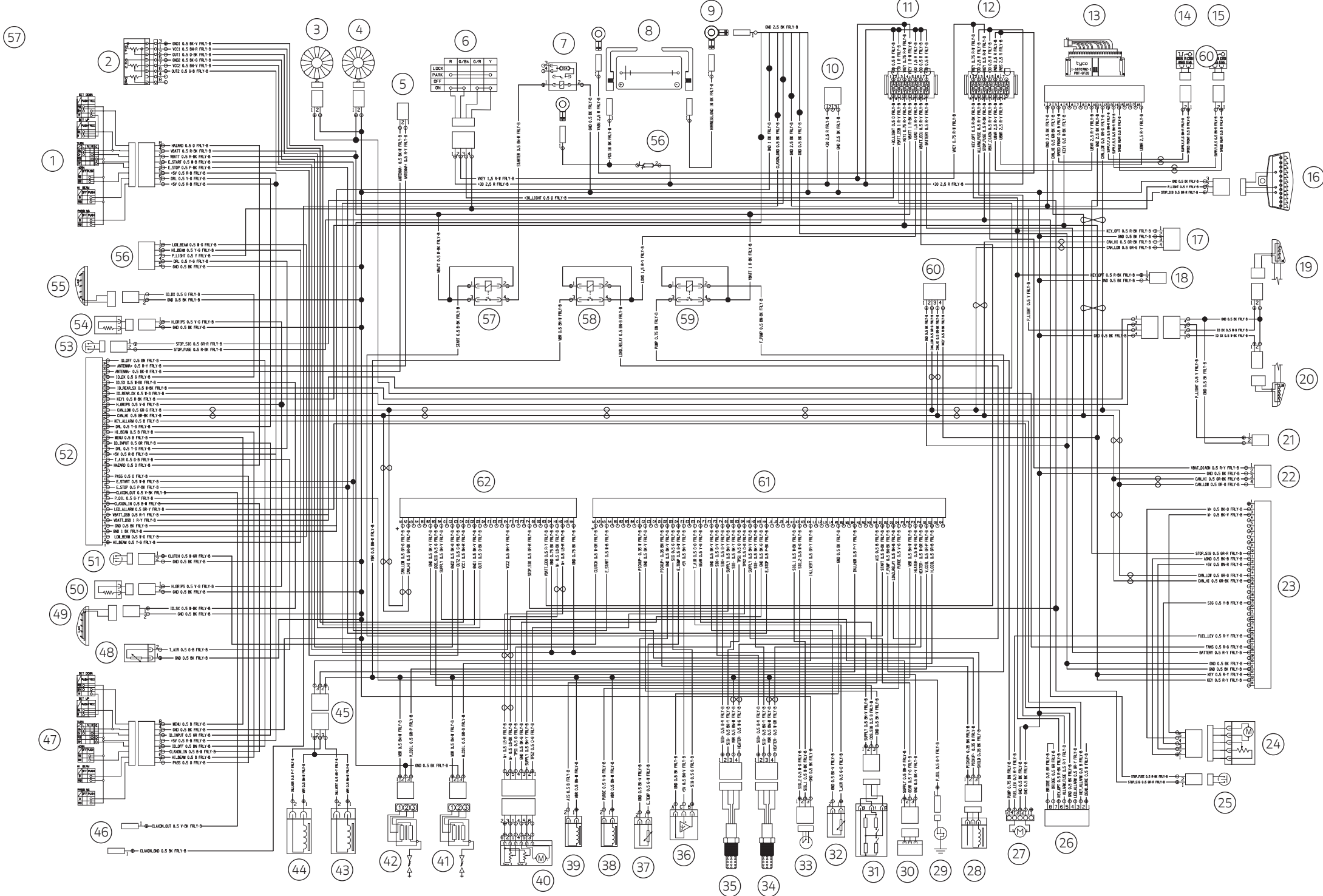

HYPERMOTARD 950 / HYPERMOTARD 950 SP

**Ducati Motor Holding spa**  
ducati.com

Via Cavalieri Ducati, 3  
40132 Bologna, Italy  
Ph. +39 051 6413111  
Fax +39 051 406580

A Sole Shareholder Company  
A Company subject to the Management  
and Coordination activities of AUDI AG