

Owner's manual

**HYPERMOTARD**

**HYPERMOTARD  
796**



***HYPERMOTARD***

***HYPERMOTARD  
796***



We would like to welcome you among Ducati enthusiasts, and congratulate you on your excellent choice of motorcycle. We think you will ride your Ducati motorcycle for long journeys as well as short daily trips. Ducati Motor Holding S.p.A. wishes you smooth and enjoyable riding.

We are continuously working to improve our Technical Assistance service. For this reason, we recommend that you strictly follow the instructions in this manual, especially those regarding the running-in period. In this way, you can be sure your Ducati motorcycle will continue to be a pleasure to ride.

For repairs or advice, please contact one of our authorised service centres.

We also provide an information service for all Ducati owners and enthusiasts for any advice and suggestions you might need.

Enjoy the ride!



## Note

Ducati Motor Holding S.p.A. declines any liability whatsoever for any mistakes incurred in drawing up this manual. All information in this manual is valid at the time of going to print. Ducati Motor Holding S.p.A. reserves the right to make any modifications required due to the ongoing development of their products.

For your safety, as well as to preserve the warranty, reliability and worth of your motorcycle, use original Ducati spare parts only.



## Warning

This manual forms an integral part of the motorcycle and - if the motorcycle is resold - must always be handed over to the new owner.

# E Table of contents

## General Indications 7

- Warranty 7
- Symbols 7
- Useful road safety information 8
- Riding with a full load 9
- Identification data 10

## Instrument panel (Dashboard) 11

- Instrument panel 11
- LCD unit functions 13
- LCD – How to set/display parameters 15
- Total distance covered indicator: "Odometer" 18
- Vehicle speed indication 19
- Oil temperature indicator 20
- "TRIP" meter 21
- Distance travelled on fuel reserve: "TRIP FUEL" 22
- Clock display indicator 23
- Service indicator 24

- Battery voltage indicator (BAT) 25
- Engine idle RPM setting (RPM) 26
- Backlighting setting (LIGHT SET) 27
- LAP time display function 28
- Stored data display (LAP Memory) 30
- DDA data acquisition 31
- Data deletion (Erase DDA) 32
- Clock setting function 33
- Instrument panel diagnostics 34
- Turn indicators automatic "RESET" function 36
- "Gradual" headlight ON/OFF function 36
- Headlight "smart" auto-off 36
- The immobilizer system 37
- Code card 38
- Immobilizer override procedure 39
- Duplicate keys 41
- Service menu - units of measurement (UNIT SET) 42

## Controls 44

- Position of motorcycle controls 44
- Key-operated ignition switch and steering lock 45
- Lh switch 46
- Clutch lever 47
- RH switch 48
- Throttle twistgrip 48
- Front brake lever 49
- Rear brake pedal 50
- Gear change pedal 50
- Adjusting the position of the gearchange and rear brake pedals 51

## Main components and devices 53

- Position on the vehicle 53
- Fuel tank plug 54
- Opening the seat 55
- Opening the tool kit compartment 56
- Side stand 57
- Rear shock absorber adjusters 58
- Rear view mirror adjustment 60

## Riding the motorcycle 61

- Running-in recommendations 61
- Pre-ride checks 63
- Starting the engine 64
- Moving off 66
- Braking 66
- Stopping the motorcycle 67
- Parking 67
- Refuelling 68
- Tool kit and accessories 69

## Main maintenance operations 70

- Removing the fairing 70
- Checking brake and clutch fluid level 72
- Checking brake pads for wear 74
- Lubricating cables and linkages 75
- Throttle cable adjustment 76
- Charging the battery 77

- Checking drive chain tension 78
- Lubricating the drive chain 79
- Replacing the headlight bulbs 80
- Changing the rear turn indicator bulbs 82
- Replacing the number plate light bulbs 83
- Beam setting 84
- Beam adjustment 85
- Tubeless tyres 86
- Checking engine oil level 88
- Cleaning and replacing the spark plugs 89
- General cleaning 90
- Storing the motorcycle 91
- Important notes 91

## Maintenance 92

- Programmed maintenance plan: operations to be carried out by the dealer 92
- Programmed maintenance plan: operations to be carried out by the customer 95

## Technical data 96

- Overall dimensions (mm) 96
- Weights 96
- Engine 98
- Timing system 98
- Performance data 99
- Spark plugs 99
- Fuel system 99

**E**

Exhaust system 99  
Transmission 100  
Brakes 101  
Frame 102  
Wheels 102  
Tyres 102  
Suspension 103  
Colour schemes 103  
Electric system 103

Routine maintenance record 108

For United States of America version  
Only 109

Routine maintenance record 119

# General Indications

## Warranty

In your own interest, and in order to guarantee product reliability, you are strongly advised to refer to our authorised Dealers and workshops for any servicing requiring particular technical expertise.

Our highly skilled staff have the tools required to perform any servicing job to the highest professional standards, using only Ducati original spare parts to ensure full interchangeability, smooth running and long life.

All Ducati motorcycles come with a Warranty Booklet. The warranty does not apply to motorcycles used in competitions or in cases where there is evidence of poor maintenance. If any motorcycle part is tampered with, modified, or replaced with parts other than original Ducati spare parts during the warranty period, the warranty is automatically invalidated.

## Symbols

Ducati Motor Holding S.p.A. advises you to read this manual carefully in order to familiarise yourself with your motorcycle. If in doubt, please contact a Ducati Dealer or Authorised Service Centre. The information contained herein will prove useful on your trips - and Ducati Motor Holding S.p.A. wishes you smooth, enjoyable riding - and will help you keep the performance of your motorcycle unchanged for a long time. This booklet uses a set of symbols with special meanings:



### Warning

Failure to comply with these instructions may put you at risk, and could lead to severe injury or even death.



### Important

Risk of damage to the motorcycle and/or its components.



### Note

Additional information about the current operation.

The terms RIGHT and LEFT are referred to the motorcycle viewed from the riding position.



## Useful road safety information



### Warning

Read this section before riding your motorcycle.

Many accidents are the result of the inexperience of the rider. Always make sure you have your licence with you; you need a valid licence that entitles you to ride a motorcycle.

Do not lend your motorcycle to persons who are inexperienced or do not hold a valid licence.

Both rider and pillion passenger must ALWAYS wear a safety helmet.

Do not wear loose clothes or accessories that could become tangled in the controls or limit your field of vision.

Never start or run the engine indoors. Exhaust gases are toxic and may lead to loss of consciousness or even death within a short time.

The rider should keep his/her feet on the footrests when the motorcycle is in motion.

ALWAYS hold the handlebars firmly with both hands in order to be ready for sudden changes of direction or in the road surface. The pillion passenger should ALWAYS hold on to the special grab handle onto tail guard with both hands.

Ride within the law and observe national and local rules.

ALWAYS respect speed limits where these are posted.

However, ALWAYS adjust your speed to the visibility, road and traffic conditions you are riding in.

ALWAYS signal your intention to turn or pull to the next lane in good time using the suitable turn indicators.

Be sure you are clearly visible and do not ride within the blind spot of vehicles ahead.

Be very careful at road junctions, or when riding in areas near exits from private land or car parks, or on the slip roads to motorways.

ALWAYS turn off the engine when refuelling.

Be extremely careful not to spill fuel on the engine or on the exhaust pipe when refuelling.

Do not smoke when refuelling.

While refuelling, it is possible to inhale noxious fuel vapours. Should any fuel drops be spilled on your skin or clothing, immediately wash with soap and water and change your clothing.

ALWAYS remove the key when you leave your motorcycle unattended.

The engine, exhaust pipes and silencers remain hot for a long time.



### Warning

The exhaust system might be hot, even after engine is switched off; take special care not to touch exhaust system with any part of your body and do not park the motorcycle next to inflammable material (wood, leaves etc.).

Park your motorcycle where no one is likely to knock against it, and use the sidestand.

Never park on uneven or soft ground or your motorcycle may fall over.

## Riding with a full load

Your motorcycle is designed for travelling over long distances with a full load in complete safety.

Even weight distribution is critical to preserving these safety features and avoiding trouble when performing sudden manoeuvres or riding on bumpy roads.

## Information on load capacity

The total weight of the motorcycle in running order including rider, passenger, luggage and additional accessories should not exceed:

390 kg.

Arrange your luggage or heavy accessories in the lowest possible position and close to motorcycle centre.

Secure the luggage firmly to the motorcycle structure.

Improperly secured luggage may affect stability.

Never attach bulky or heavy objects to the steering head or front mudguard, as this would cause dangerous instability.

Do not insert objects into gaps in the frame, where they could interfere with moving parts.

Make sure the tyres are inflated to the proper pressure indicated at page 86 and that they are in good condition.

## Identification data

All Ducati motorcycles have two identification numbers, for frame (fig. 1) and engine (fig. 2).

---

Frame number

---

Engine number

---



### Note

These numbers identify the motorcycle model and should always be indicated when ordering spare parts.

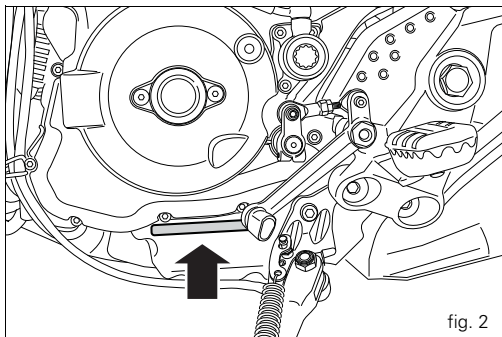
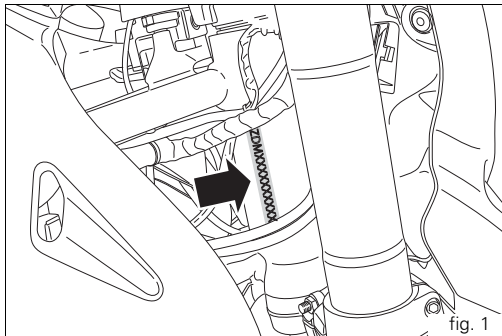

# Instrument panel (Dashboard)

## Instrument panel

- 1) LCD, (SEE PAGE 13)
- 2) REVOLUTION COUNTER (rpm).
- 3) NEUTRAL LIGHT N (GREEN).

Indicates engine revs per minute.

- 4) FUEL WARNING LIGHT  (AMBER).

Comes on when fuel is low and there are about 3.5 litres of fuel left in the tank.

- 5) TURN SIGNAL LIGHTS  (GREEN).

Comes on flashing when the turn indicators are on.

- 6) ENGINE OIL PRESSURE LIGHT  (RED).

Illuminates when engine oil pressure is too low. It briefly comes on when the ignition is switched to ON and normally goes out a few seconds after engine starts.

It may come on briefly if the engine is very hot, but should go out again as engine speed increases.

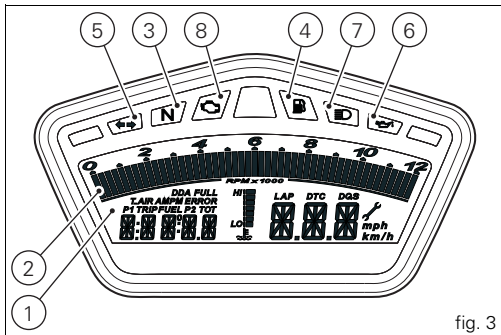



fig. 3

## Important

If this light (6) stays on, stop the engine to avoid serious damage.

- 7) HIGH BEAM LIGHT  (BLUE).

Illuminates when the high beam headlight is on.

- 8) "VEHICLE/ENGINE DIAGNOSIS- EOBD" LIGHT  (AMBER).

When on, this light is used by the control unit to signal the presence of "Engine" and/or "Vehicle" errors and sometimes the consequent engine disabling.

**E** 9) REV LIMITER LIGHT - OVER REV (RED):

Light 9B + 9C: These lights come on steady at 400 rpm below the limiter threshold.

Light 9A + 9B + 9C: These lights come on steady at 800 rpm below the limiter threshold.

Light 9A + 9B + 9C: they start flashing when the rev limiter is reached.

10) CONTROL SWITCH (fig. 5)

Button used to display and set instrument panel parameters "▲".

11) CONTROL SWITCH (fig. 5)

Button used to display and set instrument panel parameters "▼".

12) HIGH-BEAM FLASH BUTTON FLASH (fig. 5)

The high-beam flash button may also be used to control the LAP functions and the instrument panel DDA data logger.

13) TURN INDICATORS OFF BUTTON (fig. 5)

The turn indicators off button may also be used to RESET/CONFIRM function selections on the instrument panel.

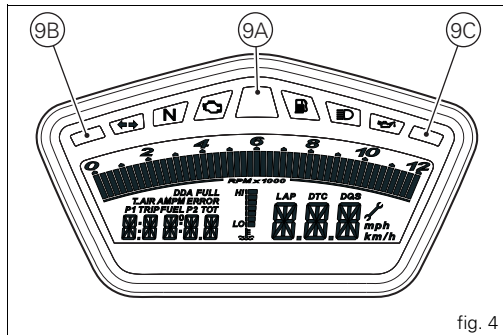

fig. 4

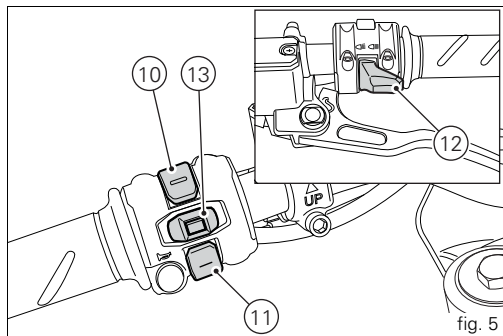

fig. 5

## LCD unit functions



### Warning

Any adjustments to the instrument panel must only be carried out when the motorcycle is stationary. Never operate the instrument panel controls while riding the motorcycle.

1) SPEEDOMETER.

Gives road speed

2) ODOMETER.

Shows total distance travelled.

3) Trip meter.

Indicates the distance travelled since last reset.

4) TRIP FUEL METER.

Shows distance travelled on reserve fuel.

5) CLOCK.

6) LAP TIMER.

7) ENGINE RPM INDICATOR (RPM).

8) LAP TIMER, MAX. RPM (LAP) AND LIMITER STATE (IF REACHED).

9) BATTERY VOLTAGE INDICATOR (BATT).

10) ENGINE OIL TEMPERATURE INDICATOR.

Indicates the engine oil temperature.



### Important

Stop riding if the temperature reaches the maximum value, otherwise the engine might be damaged.

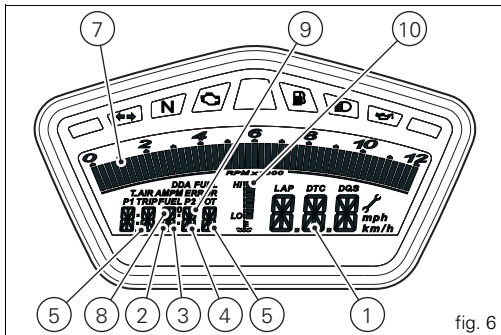

fig. 6

#### 11) MAINTENANCE COUNTER INDICATOR.

This indicator comes on to indicate that the vehicle is due for service.

It stays on until it is RESET at a Ducati Dealer or authorised Service Centre as part of the service procedure.

#### 12) LAP FUNCTION.

Indicates that the LAP function has been activated.

#### 13) DDA FUNCTION.

Indicates activation of the DDA function.

### Important

The instrument panel incorporates diagnostic functions for the electronic injection/ignition system. If you accidentally access a restricted menu, do not under any circumstances attempt to use it, but turn the ignition key to OFF. Contact a Ducati Dealer or authorised Service Centre for the necessary inspections.

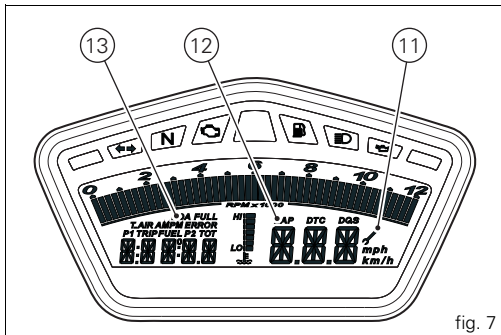

fig. 7

## LCD – How to set/display parameters

When the key is turned from OFF to ON, the instrument panel turns on all LCD digits for one second and all warning lights one by one.

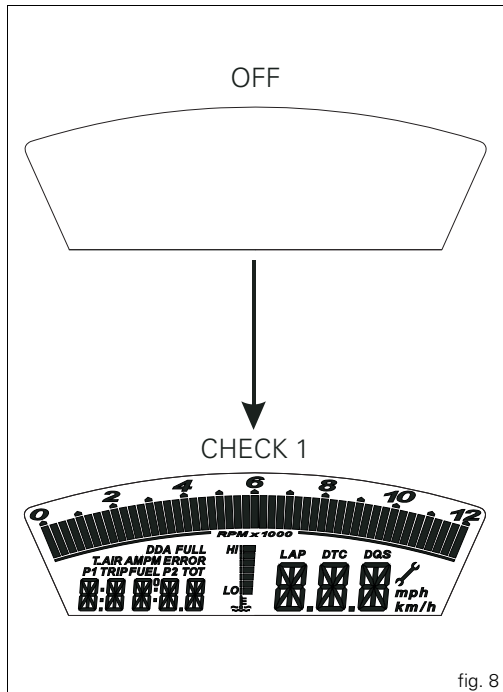

fig. 8



E It then switches to "normal" display mode showing the model indication in place of the odometer and, for 2 seconds, even the version (EU, UK, USA, CND, FRA, JAP) in place of the road speed readout.

Model is displayed once as scrolling text.

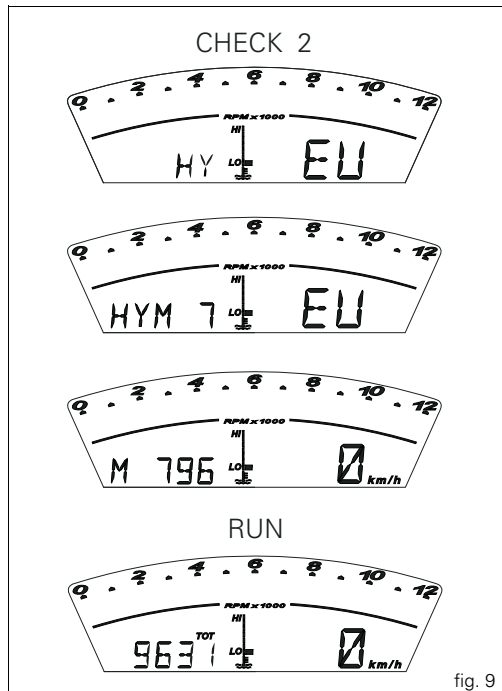

fig. 9

At Key-On, the instrument panel always shows the following information (deactivating any previously activated functions):

ODOMETER

SPEED

RPM BARGRAPH

ENGINE OIL TEMPERATURE BARGRAPH

With the button (1, fig. 10) "▲", the ODOMETER READOUT (TOT) will cycle through the following functions:

TRIP

TRIP FUEL (only if active)

CLOCK

until cycling back to the ODOMETER (TOT) function.

Pressing button (2, fig. 10) "▼" gives access to the MENU and the following functions are displayed one after another:

ERROR (only if at least one error is present)

BATT

RPM

LIGHT SET

LAP (OFF or ON)

LAP MEM

DDA (OFF or ON)

ERASE DDA

TIME SET

CODE (active only if there is at least one IMMOBILIZER error)

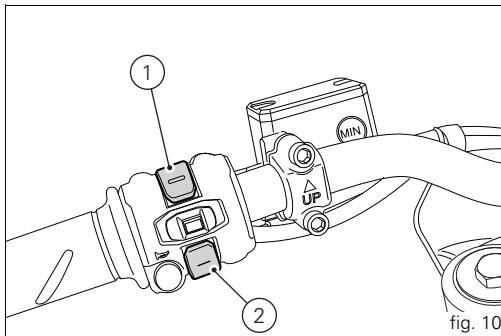

### Important

This menu is active only if the speed of the motorcycle is less than 20 km/h. If this menu is open and the speed of the motorcycle exceeds 20 km/h, the instrument panel automatically exits the menu and returns to the initial display. It is possible to exit the MENU at any time, however, by pressing switch (2, fig. 10) "▼" for 3 seconds.

## E Total distance covered indicator: "Odometer"

This function shows the total distance covered by the vehicle.

At Key-On the system automatically enters this function.

The reading is saved permanently and cannot be reset under any circumstances.

If the distance travelled exceeds 99999 km (or 99999 miles), the value "99999" will be displayed permanently.

EU, CND, FRA, JAP versions

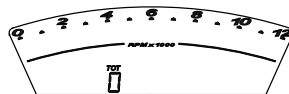

UK, USA versions

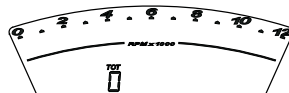

fig. 11

## Vehicle speed indication

This function shows vehicle speed.

Speed indication is obtained from actual speed information (in km/h) from the ECU increased by 8%.

Maximum speed displayed is 299 km/h (186 mph).

Over 299 km/h (186 mph) the display will show a series of dashes " - - - " (steadily lit - not flashing).

EU, CND, FRA, JAP versions

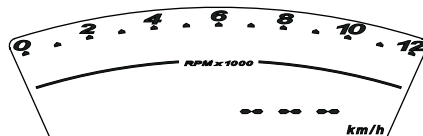
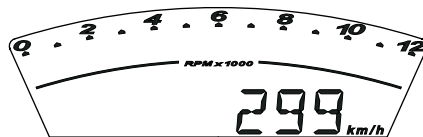

UK, USA versions

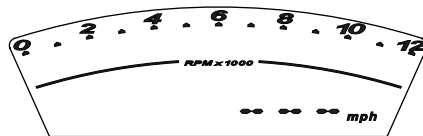
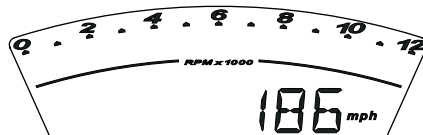

fig. 12

## Oil temperature indicator

This function displays the engine oil temperature indication.

Display indications:

- if the temperature is between  $-40\text{ }^{\circ}\text{C}$  and  $+70\text{ }^{\circ}\text{C}$ , the display shows "STATUS 2";
- if the temperature is between  $+71\text{ }^{\circ}\text{C}$  and  $+90\text{ }^{\circ}\text{C}$ , the display shows "STATUS 3";
- if the temperature is between  $+91\text{ }^{\circ}\text{C}$  and  $+175\text{ }^{\circ}\text{C}$ , the display shows "STATUS 4";
- if the temperature is between  $+176\text{ }^{\circ}\text{C}$  and  $+187\text{ }^{\circ}\text{C}$ , the display shows "STATUS 5";
- if the temperature is between  $+188\text{ }^{\circ}\text{C}$  and  $+192\text{ }^{\circ}\text{C}$ , the display shows "STATUS 6";
- if the temperature is between  $+193\text{ }^{\circ}\text{C}$  and  $+196\text{ }^{\circ}\text{C}$ , the display shows "STATUS 7";
- if the temperature is between  $+197\text{ }^{\circ}\text{C}$  and  $+199\text{ }^{\circ}\text{C}$ , the display shows "STATUS 8";
- if the temperature is  $200\text{ }^{\circ}\text{C}$  the display shows "STATUS 9" with the series of flashing marks;

In case of sensor FAULT, "STATUS 1" is displayed flashing.

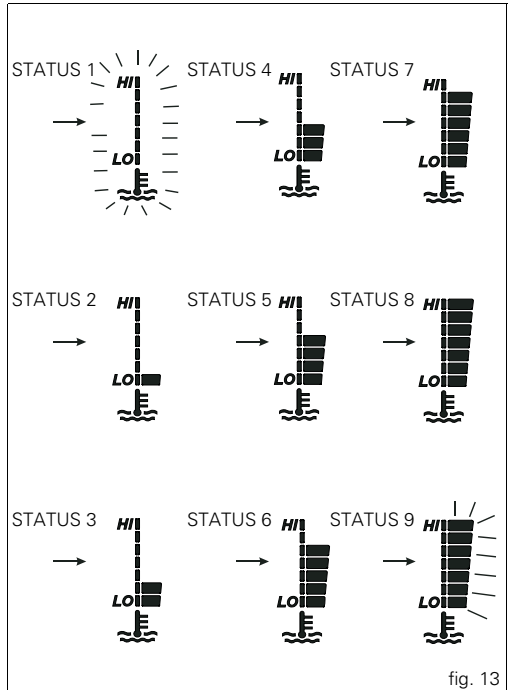

fig. 13

## “TRIP” meter

This function shows the distance travelled since the Trip meter was last reset.

Holding button (13, fig. 5) pressed for 3 seconds when this function is displayed resets the trip meter.

If the reading exceeds 999.9, it is reset to zero and the count restarts automatically.

EU, CND, FRA, JAP versions



UK, USA versions



fig. 14

## E Distance travelled on fuel reserve: "TRIP FUEL"

This function shows the distance travelled on fuel reserve. When the fuel light comes on, the display automatically switches to the "TRIP FUEL" indicator.

If the fuel level remains in reserve, the reading is saved even after Key-Off.

The count stops automatically when the fuel level rises above reserve.

If the reading exceeds 999.9, it is reset and the count restarts automatically.

EU, CND, FRA, JAP versions

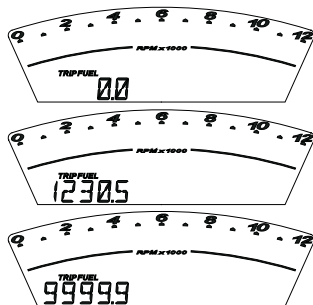

UK, USA versions

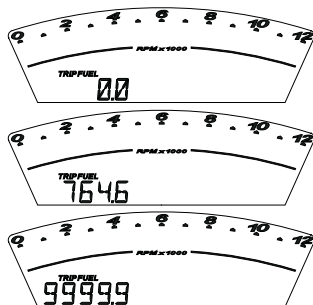

fig. 15

## Clock display indicator

This function shows the time.

Time is always displayed as follows:

AM from 0:00 to 11:59

PM from 12:00 to 11:59

If battery power is suddenly cut off (Batt-OFF), when battery power is restored and upon next Key-On, the clock is reset and restarts operating from "0:00".

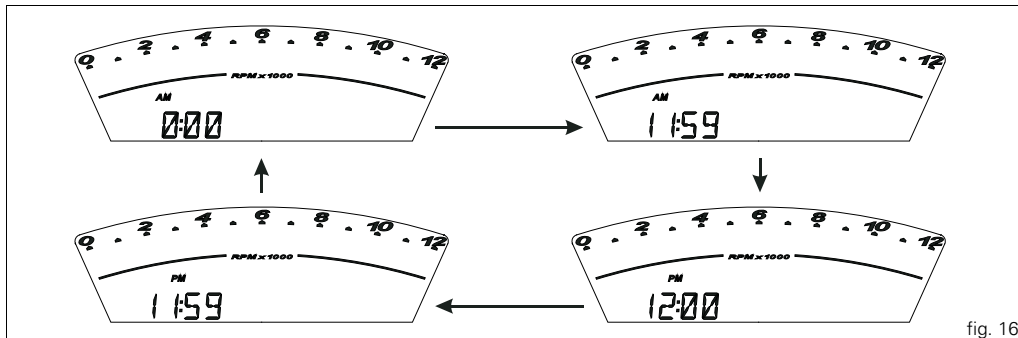

fig. 16



## Service indicator

It shows service intervals (service).

Indicator ( ) comes on to indicate that the vehicle is due for service.

The dashboard shows the service reminder at the following intervals:

after the first 1000 km on the odometer;  
every 12000 km on the odometer.

The indication remains displayed until it is reset.

When the service indicator appears, contact your Ducati dealer or Authorised Service Centre.

EU, CND, FRA, JAP  
versions

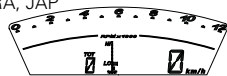

RESET



"MAINT"  
on

"MAINT"  
on

UK, USA  
versions

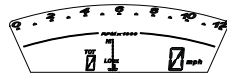

RESET



"MAINT"  
on

"MAINT"  
on

fig. 17

## Battery voltage indicator (BAT)

This function provides battery voltage indication.

To view this function, access the menu and enter the "BAT" page.

The dashboard shows battery voltage indication as follows:

- if voltage is between 12.1 and 14.9 Volt, the reading is on steady;
- if voltage is between 10.0 and 12.0 Volt or between 15.0 and 16.0 Volt, the reading will be flashing;
- if voltage is 9.9 Volt or less, the word "LO" is shown flashing and the Vehicle/Engine Diagnosis light (EOBD) (8, fig. 3) comes on;
- if voltage is = 16.1 Volt or higher, the word "HI" is shown flashing and the "Vehicle/Engine Diagnosis- EOBD" light (8, fig. 3) comes on.

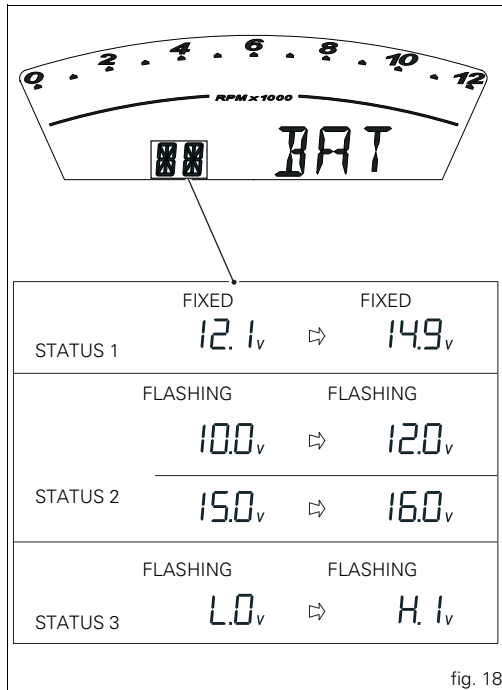

fig. 18

## Engine idle RPM setting (RPM)

This function describes engine idle setup.

To view this function, access the "RPM" page of the menu.

In addition to the rev counter scale at the top, the dashboard displays engine rpm as a numeric value for improved accuracy when setting idle rpm.

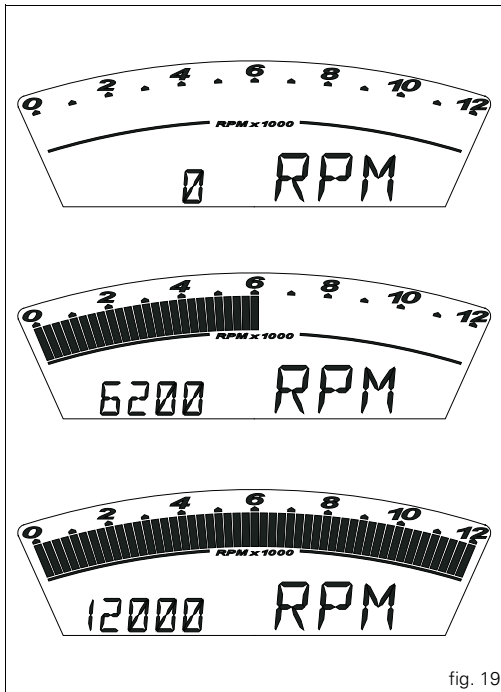

fig. 19

## Backlighting setting (LIGHT SET)

This function allows dashboard backlighting setting.

To enable this function, access the "LIGHT SET" page of the menu.

From this page, press the RESET button (13, fig. 5) for 3 seconds to enter setup mode; the following pages are displayed one after the other:

Page 1 - "LIGHT MAX" set up:

With this option, backlighting is at maximum power; press switch (1, fig. 10) "▲" to go to page 2.

Page 2 - "LIGHT MID" set up:

With this option, backlighting is about 30% less than maximum power; press switch (1, fig. 10) "▲" to go to page 3.

Page 3 - "LIGHT MIN" set up:

With this option, backlighting is about 70% less than maximum power; press switch (1, fig. 10) "▲" to return to page 1.

If you press the RESET button (13, fig. 5) for 3 seconds in one of these three pages, the instrument panel goes back to the initial "LIGHT SET" page and stores the selected backlighting setup.

If battery power is suddenly cut off (Batt-OFF), when battery power is restored and upon next Key-On, the backlighting setting is set to maximum.

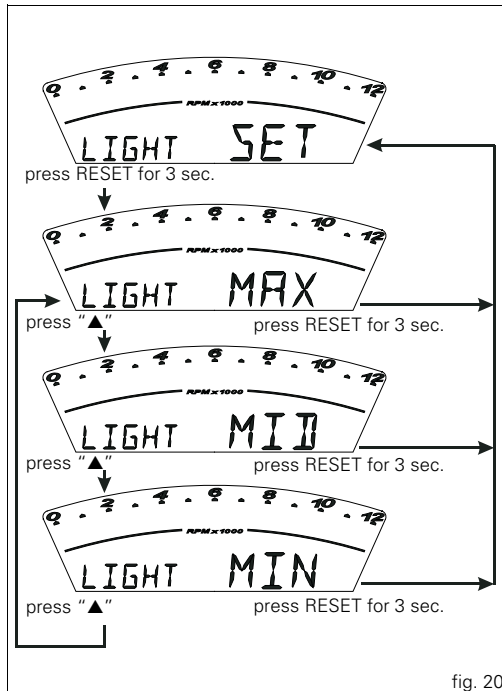

fig. 20

## LAP time display function

This function lets you display lap times.

To enable this function, enter the menu and set the LAP function to "On" by holding the RESET button (13, fig. 5) pressed for 3 seconds;

The lap timer is started and stopped using the high-beam flash button FLASH (12, fig. 5) on the LH switch.

When the LAP function is active, each time you press the flash button, the display will show the lap time for 10 seconds, before reverting to normal mode.

You can save a maximum of 30 laps in the memory.

If the memory is full, each time you press the flash button, no more lap times can be saved and the display will show the flashing message "FULL" for 3 seconds until the memory is reset.

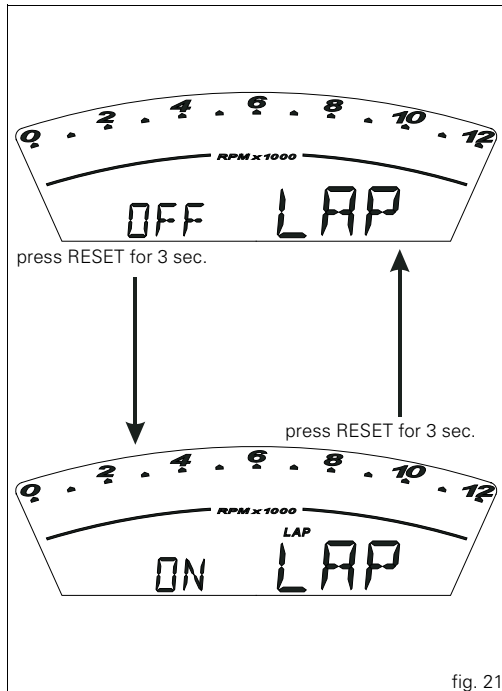

fig. 21

When the LAP function is set to Off in the menu, the current "lap" is not stored.

The LAP function is disabled automatically if the key is turned to Off (Key-Off) while it is active and the current "lap" is not stored even though the lap timer had been active before Key-Off.

If the lap timer is not stopped, it will roll over upon reaching 9 minutes, 59 seconds and 99 hundredths; the lap timer starts counting from 0 (zero) and will keep running until the function is disabled.

If however the LAP function is switched on and the memory has not been cleared, but fewer than 30 laps have been saved (e.g. 18 laps stored), the dashboard will store new laps until the memory is full (in this instance, 12 more laps).

This function only displays lap times once; display of other information stored (MAX RPM, limiter threshold reached) is provided by the Lap Memory function.

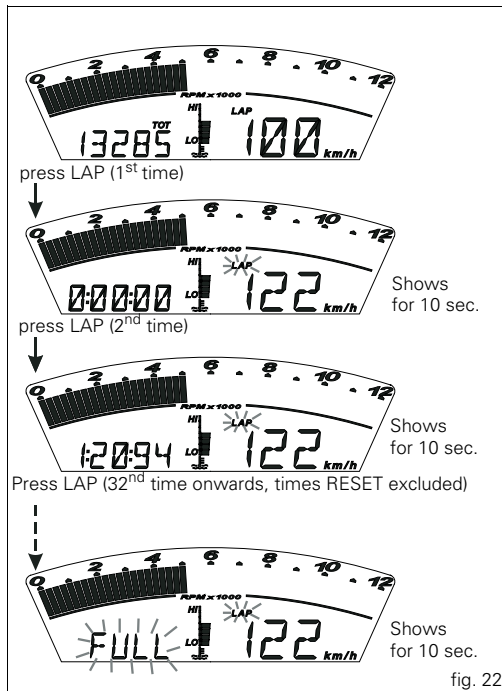

## Stored data display (LAP Memory)

Displays the data saved using the LAP function: lap time, MAX RPM and rev limiter, if kicked in.

To display the saved lap times, go into the menu and select the "LAP MEM" page.

Holding the RESET button (13, fig. 5) pressed for 3 seconds in this menu page accesses the "1<sup>st</sup> lap" view mode. the dashboard will show lap number, lap time, and MAX RPM reached during that lap.

Press button (1, fig. 10) "▲" repeatedly to scroll through the 30 laps stored until returning to the 1st lap.

If you press the RESET button (13, fig. 5) for 3 seconds while the saved times are displayed, the instrument panel immediately resets all the saved times; In this case, if the LAP function was active, it is switched off automatically.

If the memory is empty, the display shows the 30 times, with the lap timer reading "00.00.00", MAX RPM = 0 and MAX speed = 0.

If the engine reached one of the two thresholds before the limiter or the limiter threshold during a lap, the corresponding lights (9, fig. 3) come on while viewing stored lap times.

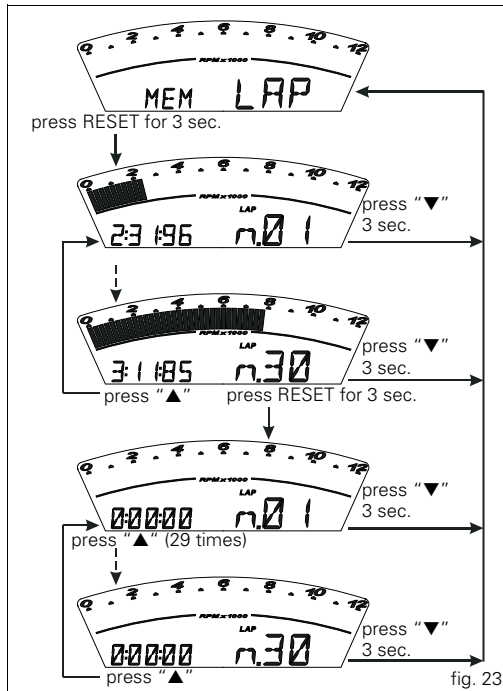

fig. 23

## DDA data acquisition

This function activates the DDA (Ducati Data Analyzer) (not included in the standard equipment for this model, but it can be purchased from the Ducati sales network): the DDA must be connected to the motorcycle wiring.

To enable this function, enter the menu and set "DDA" data logger to "On" by holding the RESET button (13, fig. 5) pressed for 3 seconds.

To confirm that function is active, "DDA" turns on (small message) and will always be visible even out of the menu pages.

The START/STOP control for the data logger lap separator is the high-beam flash button FLASH (12, fig. 5) on the LH switch.

The DDA function is disabled automatically if the key is turned to Off (Key-Off) while it is active.



### Note

Online assistance is available to Ducati Data Analyzer (DDA) owners (<http://dda.prosa.com>). This service will provide anything necessary to correctly use the DDA with your PC: both for the device and the software for analysing the recorded data.



### Warning

After use, disconnect the DDA from the main wiring harness.

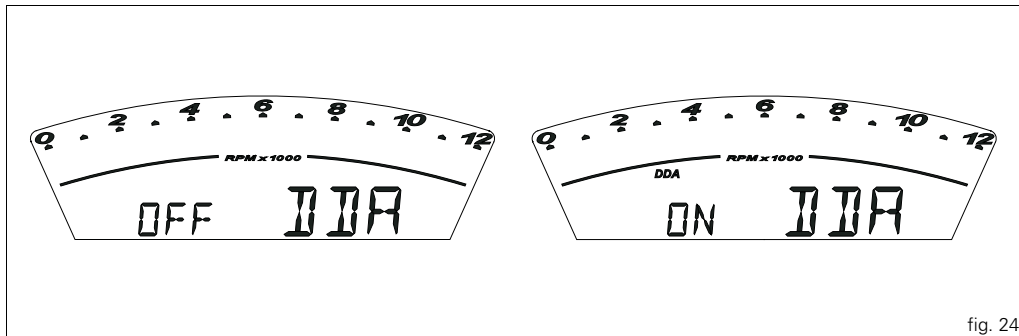

fig. 24



## Data deletion (Erase DDA)

This function enables you to delete the data saved on the DDA: the DDA must be connected to the motorcycle wiring. To delete the data, enter the menu and select the "Erase DDA" page.

If you press the RESET button (13, fig. 5) for 3 seconds and the DDA is not acquiring data, the message "WAIT..." is displayed on instrument panel for 10 seconds; after these 10 seconds, message "ERASE OK" is displayed for 2 seconds to confirm that the data in the DDA data logger have been erased.

If the RESET button (13, fig. 5) is pressed down for 3 seconds while the DDA data logger is acquiring data, the data logger memory is not erased and the dashboard displays message "FAIL" for 2 seconds.

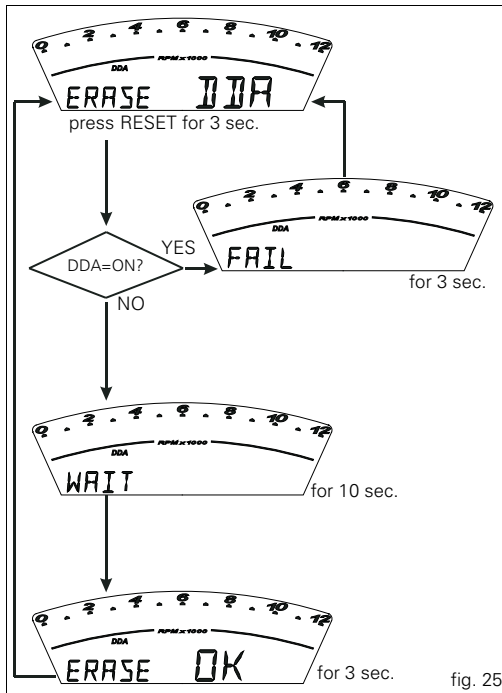

fig. 25

## Clock setting function

This function is used to set the clock time.

To set the clock, enter the menu page "TIME SET".

Holding the RESET button (13, fig. 5) pressed for 3 seconds in this menu page accesses the setup mode.

On entering this function, the message "AM" flashes on the display; if you press the button (1, fig. 10) "▲" the message "PM" flashes; if you press the button (1, fig. 10) "▲" the mode will go back to previous setting (if it is 00:00, when toggling from "AM" to "PM", 12:00 will be displayed).

pressing button (2, fig. 10) "▼" gives access to the hour setting mode; hours start to flash. Each time you press the button (1, fig. 10) "▲", the digit will increase by 1 hour; If the button is held depressed (1, fig. 10) "▲" the digit will increase by 1 hour every second (when the button is held depressed, the hours do not flash).

Pressing button (2, fig. 10) "▼" gives access to the minute setting mode; minutes start to flash. Each time you press the button (1, fig. 10) "▲", the digit will increase by 1 minute; holding down the button (1, fig. 10) "▲", the digit will increase by 1 minute each second. If the button is held depressed (1, fig. 10) "▲" for over 5 seconds, minutes will increase by 1 minute every 100ms [while the button is held depressed (1, fig. 10) "▲", seconds will not flash].

Pressing the button (2, fig. 10) "▼", exits setup mode and the new time is displayed.

press RESET for 3 sec.

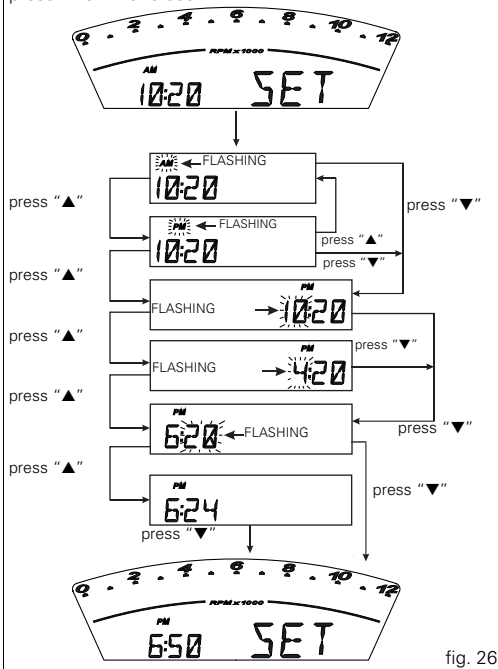

fig. 26

## Instrument panel diagnostics

### Important







The instrument runs the system diagnostics correctly 60 seconds after the last Key-Off.











Any abnormal vehicle behaviour is displayed.  
If more errors are present, they are displayed one by one every 3 seconds.  
Possible errors are listed in the table below.



### Warning

When an error is displayed, always contact a Ducati Dealer or authorised Service Center.

WARNING LIGHT	ERROR MESSAGE	ERROR
	TPS	01 Generic TPS throttle position sensor error
	PRESS	02 Generic pressure sensor error
	T OIL	03 Generic engine oil temperature sensor error
	T AIR	04 Air temperature sensor generic error
	BATT	05 Generic battery voltage error
	LAMB	06 Generic lambda sensor heater error
	FUEL	07 Generic reserve error

WARNING LIGHT	ERROR MESSAGE		ERROR
	COIL	09	Generic coil error
	INJE	10	Generic injector error
	START	12	Generic solenoid starter error
	R INJ	13	Generic relay injection error
	STEPP	14	Generic stepper motor error
	ECU	16	Generic Engine Control Unit error
	PK UP	17	Generic pick-up sensor error
	SPEED	18	Generic speed sensor error
	IMMO	19	Generic immobilizer error
	CAN	20	Generic CAN communication line error
	LIGHT	21	Generic high beam and/or low beam light error

## Turn indicators automatic “RESET” function

After activating one of the two turn indicators, user can reset them using the RESET button (13, fig. 5).

If turn indicator is not “RESET”, it will automatically switch off after the vehicle has covered 1 Km (0.6 miles) since turn indicator was activated.

## “Gradual” headlight ON/OFF function

Upon the Key-On, the Low beam (LO) turns on gradually (it takes about 2 sec. to reach full lighting state),

It also turns off “gradually” upon Key-Off (approx. 2 sec. to turn off completely).

## Headlight “smart” auto-off

This function automatically turns off the headlight when starting the motorcycle or if the key have been forgotten in the Key-On position with the engine off.

During the starting phase, to reduce battery use, the instrument panel turns the headlight off automatically and turns it on again automatically when the engine has started (immediate on and off, not gradually).

If the motorcycle is left with the key inserted (Key-On) and the engine off, the headlight will be turned off automatically after 60 seconds to reduce battery consumption. It is reactivated when the engine is restarted.

## The immobilizer system

For additional anti-theft protection, the motorcycle is equipped with an IMMOBILIZER, an electronic system that locks the engine automatically whenever the ignition switch is turned off.

The grip of each ignition key contains an electronic device that modulates the output signal from a special antenna in the switch when the ignition is switched On. The modulated signal represents the "password" (which is changed at each start-up) by which the ECU recognizes the ignition key. The ECU will only allow the engine to start if it recognises this password.

### Keys (fig. 27)

The owner receives a set of keys, comprising:

- 2 (BLACK) keys B

These contain the "code" of the immobilizer system.



### Note

Your Ducati dealer may ask you to produce your Code Card in order to carry out certain servicing operations.

The black keys (B) are the keys for normal use, and are used to:

- start up the engine
- open the fuel tank filler plug.
- open the seat lock.



### Note

The two keys have a small tag (1) attached, which shows their identification number.



### Warning

Keep the keys separately and use only one of the black keys to start the motorcycle.

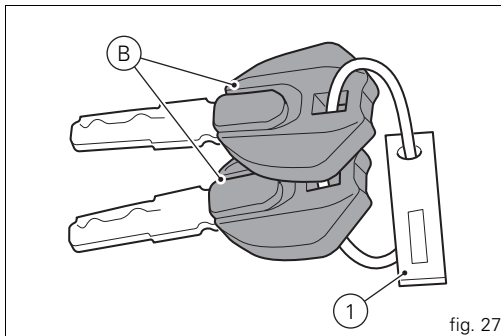

fig. 27

## Code card

The CODE CARD (fig. 28) supplied with the keys reports an electronic code (A, fig. 29) to start the engine in the event it fails to start after KEY-ON because the immobilizer system inhibited the ignition.



### Warning

Keep the CODE CARD in a safe place. However, it is advisable to keep the electronic code printed on the CODE CARD handy when you ride your motorcycle, in case it is necessary to enable the engine through the procedure described below. This procedure lets you disable the "engine block" function - indicated by the amber yellow "Engine Diagnosis EOBD" light (8, fig. 3) coming on - in the event of problems with the immobilizer system. This operation is only possible if the electronic code indicated on the code card is known.



### Warning

Your Dealer will ask you to submit your CODE CARD to reprogram a key or when you need a replacement key.

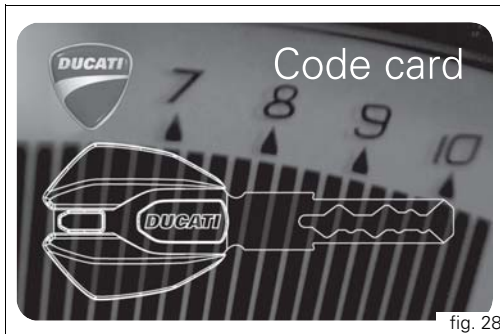

fig. 28

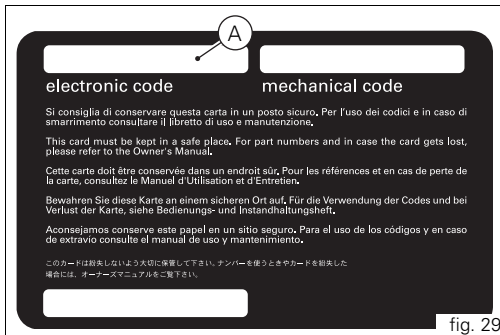

fig. 29

## Immobilizer override procedure

In the case of an "Immobilizer LOCK", this function makes it possible to enter the 5 digit electronic code located on the CODE CARD provided with the set of keys and release the motorcycle momentarily.



### Note

This menu is only active when at least one Immobilizer error is present.

With this page selected, the initial code is always displayed as "00000". If you press down on the RESET button (13, fig. 5) for 3 seconds, you will access the procedure for entering the electronic code provided on the CODE CARD.

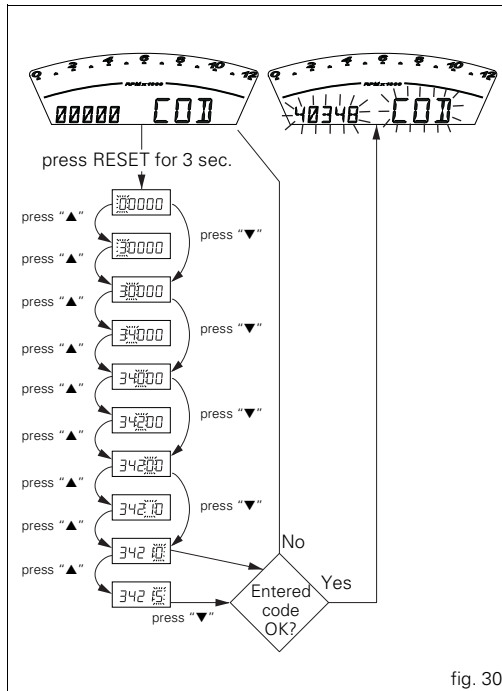



Entering the code:

on entering this function, the first digit on the left starts flashing.

Button (1 and 2, fig. 10):

each time you press the button (1, fig. 10) "▲", the digit will increase by one unit per second;

pressing button (2, fig. 10) "▼" lets you set the second digit that starts to flash. Each time you press the button (1, fig. 10)

"▲", the digit will increase by one unit per second;

pressing button (2, fig. 10) "▼" lets you set the third digit that starts to flash. Each time you press the button (1, fig. 10)

"▲", the digit will increase by one unit per second;

pressing button (2, fig. 10) "▼" lets you set the fourth digit that starts to flash. Each time you press the button (1, fig. 10)

"▲", the digit will increase by one unit per second;

pressing button (2, fig. 10) "▼" lets you set the fifth digit that starts to flash. Each time you press the button (1, fig. 10)

"▲", the digit will increase by one unit per second;

pressing the button (2, fig. 10) "▼" confirms the code.

If the code has been entered correctly, the message "CODE" and the code itself will flash simultaneously for 4 seconds; The "EOBD diagnosis" warning light (8, fig. 3) will turn off; The instrument panel then automatically exits the menu, thus allowing "temporary" starting of the motorcycle. If the error persists, at the next key-on, the instrument panel will return to an error state and immobilize the engine. If the code is not entered correctly, the instrument panel returns automatically to the "CODE" menu, displaying code "00000".



### Note

An "incorrect" code may be entered an infinite number of times without locking the function.

## Operation

When the ignition key is turned from ON to OFF, the immobilizer system activates the engine lock. When the ignition key is turned from OFF to ON to start the engine:

- 1) if the code is recognised, the protection system releases the engine lock. Press the START button (2, fig. 37), to start the engine;
- 2) if the "Vehicle/Engine Diagnosis - EOBD" light (8, fig. 3) comes on and the page with the message "IMMO" is displayed when you press button (2, fig. 10) "▼", it means that the code was not recognised. In this case, turn the ignition key back to OFF and then to ON again. If the engine still does not start, try again with the other black key. If the engine still does not start, contact the DUCATI Service network.



### Warning

Sharp knocks can damage the electronic components inside the key.

Always use the same key throughout the procedure. Failure to do so might prevent the system from recognising the code of the key in use.

## Duplicate keys

If you need additional keys, contact your DUCATI Service Centre with all the keys you have in your possession and your CODE CARD.

The Ducati Service Centre will program all the new keys as well as any keys you already have.

You may be asked to provide proof that you are the legitimate owner of the motorcycle.

The codes of any keys not submitted will be wiped off from the memory to make those keys unserviceable in case they have been lost.



### Note

If you sell your motorcycle, do not forget to give all keys and the CODE CARD to the new owner.

## E Service menu - units of measurement (UNIT SET)

This function allows you to set the units of measurement for the values displayed on the instrument panel.

To enter the menu service push button (2, fig. 10) "▼" while turning the key from "Off" to "On"



### Note

Within this menu, any other function is disabled and engine starting is disabled as well.

The first function displayed is "Immobilizer Reprogramming" (00000 PRO), press button (1, fig. 10) "▲" to display the other function of the service menu "UNIT SET".

Now press the RESET button (13, fig. 5) for 3 seconds. Each time you press switch (1, fig. 10) "▲" or (2, fig. 10) "▼", the instrument panel scrolls through the following sequence of options, which flash on the display:

UNIT OF MEASUREMENT			
Country standard	Speed	Air temperature	Odometer/ trip meters
EU	Km/h	°C	Km
EN	Mph	°C	miles
USA	Mph	°F	miles
CND	Km/h	°C	Km
FRA	Km/h	°C	Km
JAP	Km/h	°C	Km
ECU Id.	The instrument panel sets units of measurement according to ECU information		

If you press the RESET button (13, fig. 5) for 3 seconds, the option currently displayed will be saved to memory and the word "MEM" will appear.

Upon the following Key-On the instrument panel will be set to the new settings.

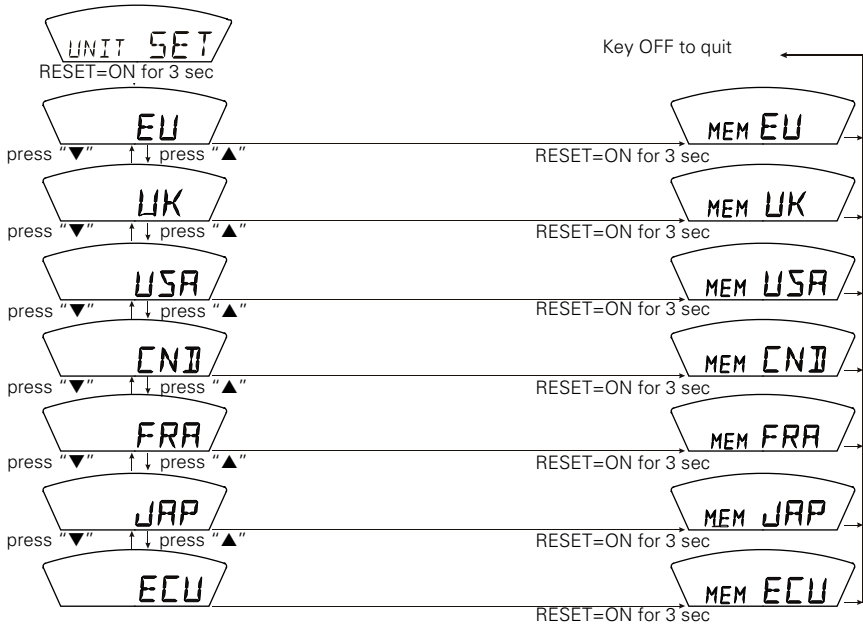

fig.31

# E Controls



## Warning

This section shows the position and function of the controls used to ride the motorcycle. Be sure to read this information carefully before you use the controls.

## Position of motorcycle controls (fig. 32)

- 1) Instrument panel.
- 2) Key-operated ignition switch and steering lock.
- 3) Left-hand handlebar switch.
- 4) Clutch lever.
- 5) Rear brake pedal.
- 6) Right-hand handlebar switch.
- 7) Throttle twistgrip.
- 8) Front brake lever.
- 9) Gear change pedal.

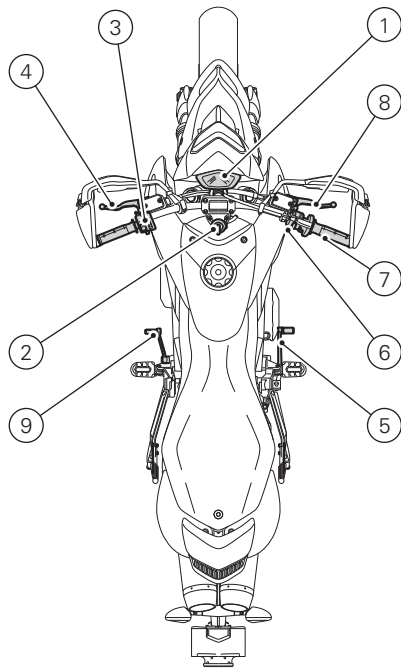

fig. 32

## Key-operated ignition switch and steering lock (fig. 33)

This is located in front of the fuel tank and has four positions:

- A) ON: enables lights and engine operation;
- B) OFF: disables lights and engine operation;
- C) LOCK: the steering is locked;
- D) P: parking light on and steering locked.







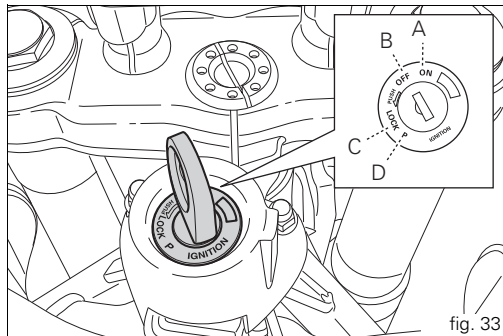

### Note

To move the key to the latter two positions, push it in before turning. The key can be removed in positions (B), (C) and (D).



## Lh switch (fig. 34 and fig. 35)

- 1) Dip switch, light dip switch, two positions:  
position  = low beam on (A);  
position  = high beam on (B).  
Button  = high-beam flasher (FLASH) and instrument panel control (C).
- 2) Switch  = 3-position turn indicator:  
centre position = OFF;  
position  = left turn;  
position  = right turn.  
To cancel turn indicators, push in once switch returns to central position.
- 3) Button  = warning horn.
- 4) Instrument panel control button "▲" position.
- 5) Instrument panel control button "▼" position.

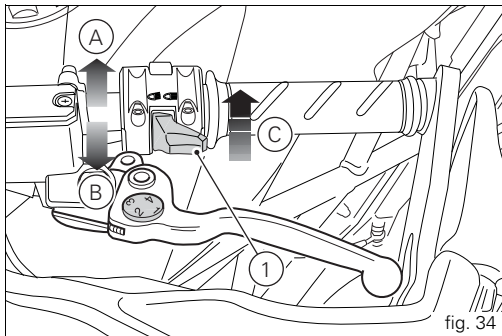

fig. 34

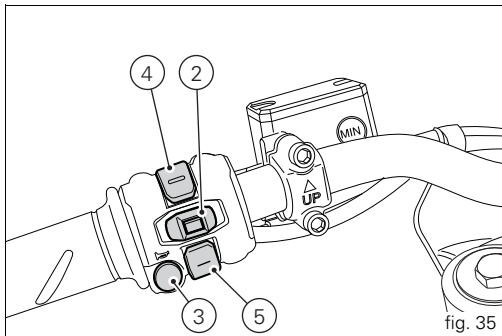

fig. 35

## Clutch lever (fig. 36)

Lever (1) disengages the clutch. It features a dial adjuster (2) for lever distance from the twistgrip on semihandlebar. To adjust it, keep lever (1) fully extended, and turn knob (2), turning it in correspondence of one of the four foreseen positions.

Keep in mind that the position no. 1 corresponds to the maximum distance between the lever and the knob, whereas position no. 4 corresponds to the minimum distance.

When the clutch lever (1) is operated, drive from the engine to the gearbox and the rear wheel is disengaged. Correct use of the clutch lever is very important in all riding situations, especially when moving off.

### Important

Using the clutch properly will prolong the life of the engine and prevent any damage to components in the transmission.

### Note

It is possible to start the engine with the side stand down and the gearbox in neutral. When starting the bike with a gear engaged, pull the clutch lever (in this case the side stand must be up).

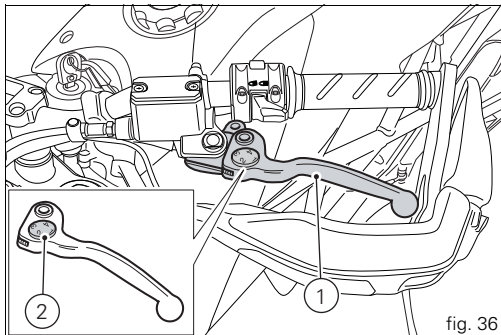



fig. 36





## RH switch (fig. 37 and fig. 38)

- 1) ENGINE STOP switch, two positions:
- position  (RUN) = run (A, fig. 38);
  - position  (OFF) = stop (B, fig. 38).



### Warning

This switch is mainly intended for use in emergencies when you need to stop the engine quickly. After stopping the engine, return the switch to the "  " position to enable starting.

- 2) Button  = engine start

## Throttle twistgrip (fig. 37)

The twistgrip (3) on the right handlebar opens the throttles. When released, it will spring back to the initial position (idling speed).

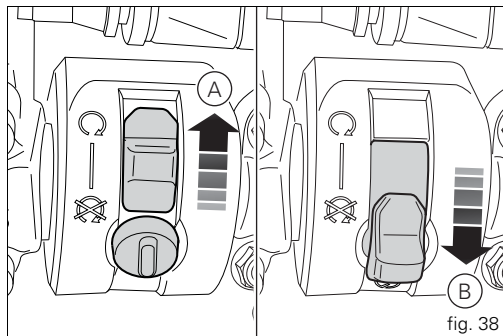
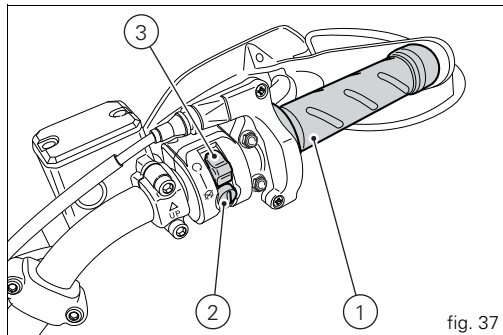

## Front brake lever (fig. 39)

Pull in the lever (1) towards the twistgrip to operate the front brake. The system is hydraulically operated and you just need to pull the lever gently.

The brake lever has a wheel (2) for adjusting the distance between lever and twistgrip on the handlebar.

To adjust it, keep lever (1) fully extended, and turn knob (2), turning it in correspondence of one of the four foreseen positions.

Keep in mind that the position no. 1 corresponds to the maximum distance between the lever and the knob, whereas position no. 4 corresponds to the minimum distance.

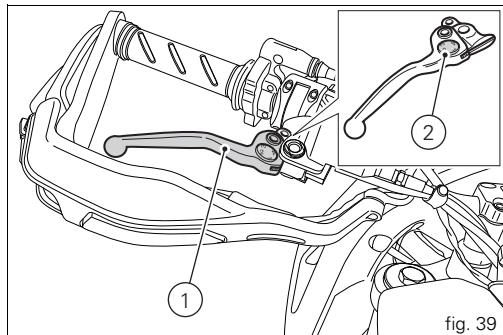

## Rear brake pedal (fig. 40)

Push down on the pedal (1) with your foot to operate the rear brake.

The brake system is hydraulic and very little force is required to operate it.

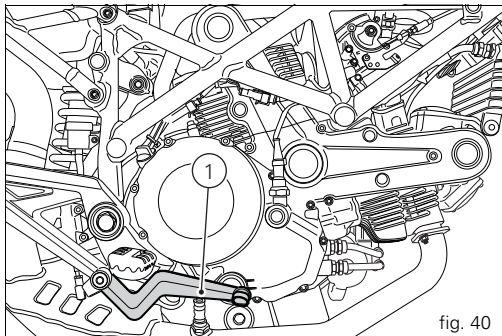

fig. 40

## Gear change pedal (fig. 41)

When released, the gear change pedal automatically returns to rest position N in the centre; this is indicated by the instrument panel light N (8, fig. 3) coming on.

The pedal can be moved:

down = press down the pedal to engage the 1<sup>st</sup> gear and to shift down. The N light will go out.

upwards= lift the pedal to engage 2<sup>nd</sup> gear and then 3<sup>rd</sup>, 4<sup>th</sup>, 5<sup>th</sup> and 6<sup>th</sup> gears.

Each time you move the pedal you will engage the next gear.

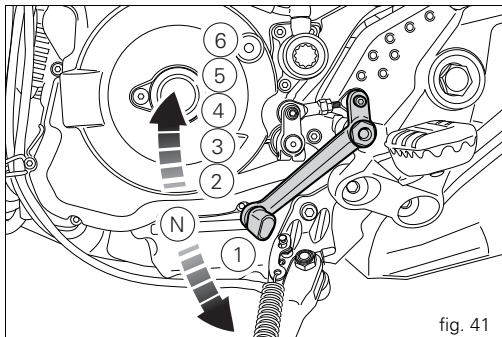

fig. 41

## Adjusting the position of the gearchange and rear brake pedals

The position of the gearchange and rear brake pedals in relation to the footrests can be adjusted to suit the requirements of the rider.

Adjust the pedals as follows:

### Gear change pedal (fig. 42)

Use an open ended spanner to hold the rod (1) on the flat (2) and slacken off lock nut (3).

Turn the screw (4) to detach the rod (5) from the gear change lever.

Turn the rod (5), until the gear change pedal is set to the desired position.

Tighten the screw (4) to secure the gearchange lever to the rod (5).

Tighten the lock nut (3) against the rod (5).

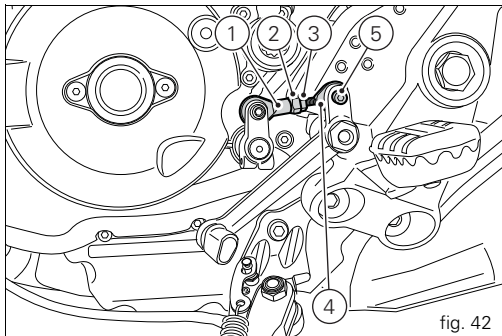

fig. 42

## Rear brake pedal (fig. 43)

loosen counter nut (7).

Turn pedal stroke adjusting screw (6) until pedal is in the desired position.

Tighten the counter nut (7).

Operate the pedal by hand to check that there is 1.5 to 2 mm of freeplay before the brake bites.

If not, adjust the length of the master cylinder pushrod as follows.

Slacken off the counter nut (10) on the pushrod.

Screw the pushrod (8) into the front fork (9) to increase the freeplay, or screw it out to reduce it.

Tighten the counter nut (10) and recheck the pedal freeplay.

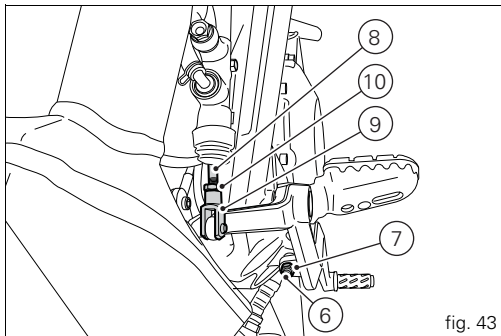

fig. 43

# Main components and devices

## Position on the vehicle (fig. 44)

- 1) Tank filler plug.
- 2) Seat.
- 3) Glove compartment door.
- 4) Side stand.
- 5) Rear shock absorber adjusters.
- 6) Rear-view mirrors.
- 7) Silencer and exhaust pipes.
- 8) Catalytic converter.



### Warning

The exhaust system might be hot, even after engine is switched off; take special care not to touch exhaust system with any part of your body and do not park the motorcycle next to inflammable material (wood, leaves etc.).

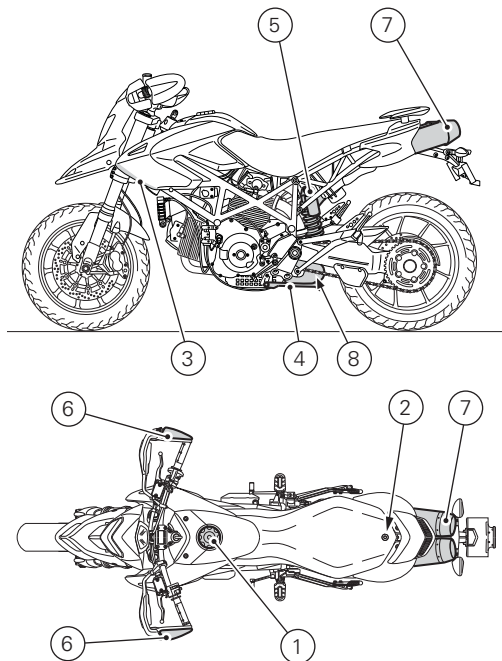

fig. 44

## E Fuel tank plug (fig. 45)

### Opening

Insert the key into the lock. Give the key a 1/4 turn clockwise to unlock.

Unscrew the plug (1, fig. 45).

### Closing

Tighten the plug (1) with the key inserted and push it down into its seat. Turn the key anticlockwise to the initial position and remove it.



### Note

The cap can only be closed with the key inserted.



### Warning

Always make sure you have properly refitted (see page 68) and closed the plug after each refuelling.

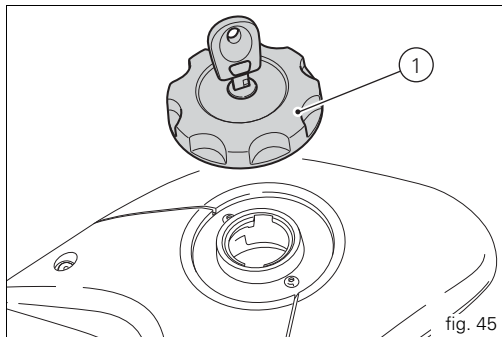

## Opening the seat

### Opening

Unscrew the screw (1) with the supplied Allen wrench and remove it.

Raise the rear end of the seat and slide it off the front supports in a rearward motion.

### Closing

Slide the front ends of the seat bottom underneath the frame U-bolt, start the screw (1) in its hole and tighten.

Ensure that the seat is fastened securely to the frame.

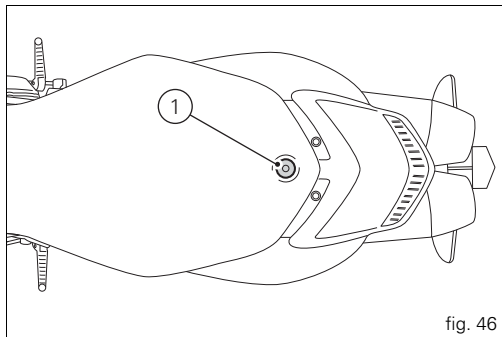

fig. 46



## Opening the tool kit compartment

To access the tool kit compartment, turn the plastic screws (1) counter clockwise by one fourth of a turn.

Remove the inner door to access the compartment that contains the tool kit (see page 69).

### Important

Do not use this compartment to hold heavy or metal objects that might move about while the motorcycle is in motion, causing loss of stability.

To close the compartment, simply refit the inner door into the left side fairing and turn the plastic screws (1) clockwise by one fourth of turn.

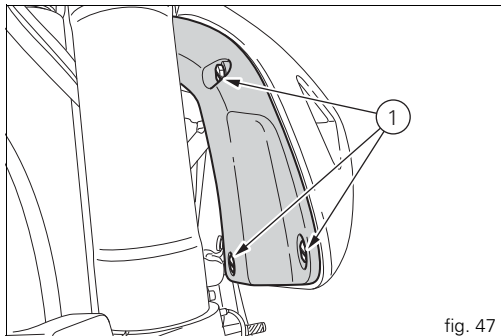

fig. 47

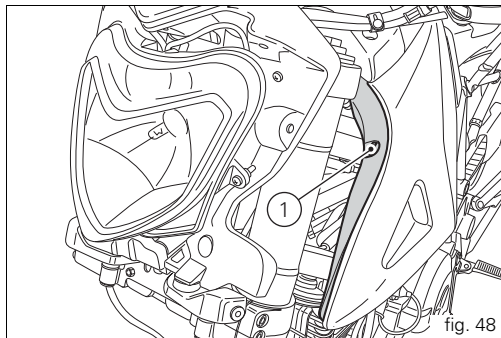

fig. 48

## Side stand (fig. 49)

### Important

Before lowering the side stand, make sure that the supporting surface is hard and flat. Do not park on soft ground, gravel or on asphalt softened by the sun etc. or the motorcycle may fall over.

When parking in downhill road tracts, always park the motorcycle with its rear wheel facing downhill.

To pull down the side stand, hold the motorcycle handlebars with both hands and push down on the thrust arm (1) with your foot until stand is fully extended. Lean the motorcycle to the left until the stand contacts the ground.

### Warning

Do not sit on the motorcycle when it is supported on the sidestand.

To move the side stand to its rest position (horizontal position), tilt the motorcycle to the right and, at the same time, lift the thrust arm (1) with your foot.



### Note

Check the correct operation of the two return springs of the stand - one spring is placed inside the other - and of the stand sensor (2) that signals stand position to the Engine Control Unit. This system is protected by a 3A fuse placed at the side of the battery (see page 104).



### Note

It is possible to start the engine with the side stand down and the gearbox in neutral. When starting the bike with a gear engaged, pull the clutch lever (in this case the side stand must be up).

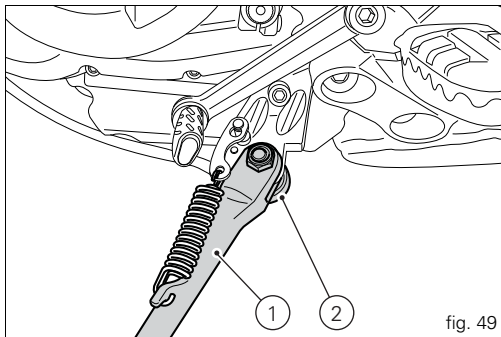

fig. 49

## Rear shock absorber adjusters (fig. 50 and fig. 51)

The shock absorber has external adjusters that enable you to adjust the setup to suit the load on the motorcycle.

The adjuster (1) located on the right-hand side, where the lower end of the shock absorber is attached to the swingarm, controls rebound damping.

Turn the adjuster (1) clockwise to increase damping H, or counter-clockwise to reduce damping S.

STANDARD setting from the fully closed position (clockwise):

- loosen the adjuster (1) by  $12 \pm 2$  clicks.

Spring preload: 23 mm

The two nuts (2) on the upper part of the shock absorber serve to adjust the preload on the external spring. To change spring preload, slacken off the upper lock nut. Then TIGHTEN or SLACKEN the lower ring nut to INCREASE or DECREASE spring preload.

STANDARD length of the preloaded spring on the shock absorber with the rear wheel raised off the ground:

$166 \pm 1.5$  mm.

### Warning

Use a pin wrench to turn the preload adjusting ring nut. Take special care when turning the ring nut, to avoid injuring your hand by striking it violently against other parts of the motorcycle if the wrench suddenly slips off the nut while turning.

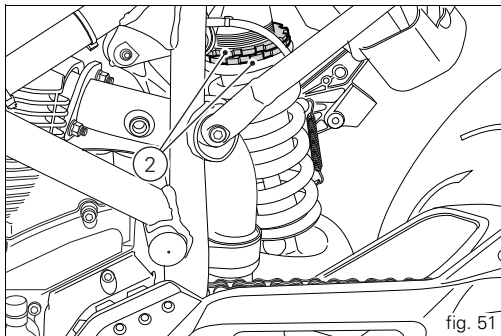
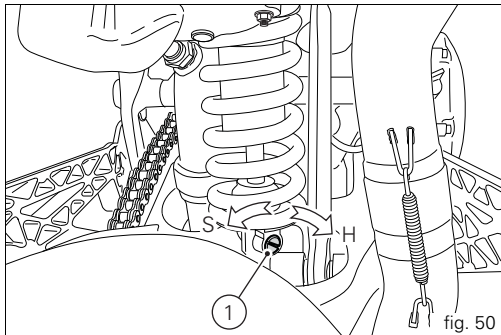



## Warning

The shock absorber is filled with gas under pressure and may cause severe damage if taken apart by unskilled persons.

When carrying a passenger and luggage, set the rear shock absorber spring to proper preload to improve motorcycle handling and keep safe clearance from the ground. You may find that rebound damping needs adjusting as well.

## Rear view mirror adjustment

Loosen ring nut (A) to adjust.

Move the rear-view mirror body (B) to the desired position and tighten the ring nut (A) to lock the mirror in position.



### Warning

Never attempt to adjust the position by moving the whole mirror assembly, as this could break it.

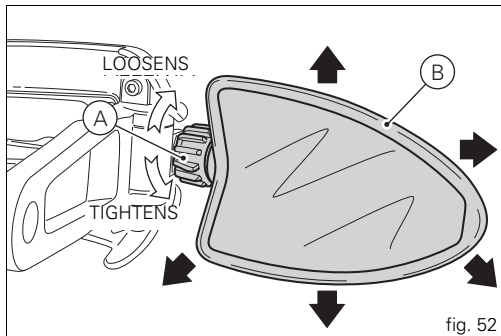

# Riding the motorcycle

For the first 100 km, use the brakes gently. Do not brake violently or keep brake applied for too long. This will enable a correct break-in of friction material on brake pads against brake discs.

To allow all the mechanical moving parts in the motorcycle to adapt to one another, and to avoid shortening the life of the main engine components, it is advisable to avoid sudden acceleration and running the engine at high rpm for too long, especially uphill.

It is also advisable to check the drive chain frequently and ensure that it is lubricated as required.

## Running-in recommendations

### Maximum rpm (fig. 53)

Rpm limits to be observed during the running-in period and in normal use:

- 1) Up to 1000 km
- 2) From 1000 to 2500 km

### Up to 1000 km

During the first 1000 km, keep an eye on the rev counter. It should never exceed 5,500÷6,000 rpm.

During the first hours of riding, it is advisable to run the engine at varying load and rpm, though still within recommended limit.

For this reason, roads with numerous bends and hilly areas are ideal for running in the engine, brakes and suspension.

### From 1000 to 2500 km

At this point, you can squeeze some more power out of your engine. However never exceed 7,000 rpm.

## Important

During the whole running-in period, the maintenance and service rules recommended in the Warranty Card should be observed carefully. Failure to comply with these rules will release Ducati Motor Holding S.p.A. from any liability whatsoever for resulting engine damage or shorter engine life.

Keeping to the running-in recommendations will ensure longer engine life and reduce the need for overhauls and re-tuning.

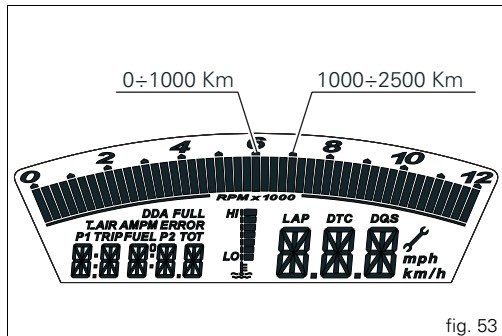

fig. 53

## Pre-ride checks



### Warning

Failure to carry out these checks before starting may result in damage to the motorcycle and injury to rider.

Before starting, check the following points:

#### FUEL LEVEL IN THE TANK

Check fuel level in the tank. Fill tank if needed (page 68).

#### ENGINE OIL LEVEL

Check the oil level in the sump through the sight glass. Top up if needed (page 88).

#### BRAKE AND CLUTCH FLUID

Check fluid level in the relevant reservoirs (page 72).

#### TYRE CONDITION

Check tyre pressure and condition (page 86).

#### CONTROLS

Work the brake, clutch, throttle and gear change controls (levers, pedals and twistgrips) and check for proper operation.

#### LIGHTS AND INDICATORS

Make sure lights, indicators and horn work properly. Replace any burnt-out bulbs (page 80).

## KEY-OPERATED LOCKS

Ensure that fuel filler plug (page 54) and passenger seat (page 55) are firmly secured.

### STAND

Make sure side stand operates smoothly and is in the correct position (page 57).



### Warning

In case of malfunction, do not ride the motorcycle and contact a Ducati Dealer or authorised Service Centre.



## Starting the engine



### Warning

Before starting the engine, become familiar with the controls you will need to use when riding (see page 44).

- 1) Move the ignition key to ON (fig. 54). Make sure the green light N (8, fig. 3) and the red light  (7, fig. 3) on the instrument panel are on.



### Important

The oil pressure light should go out a few seconds after the engine has started (page 11).



### Note

The engine can be started with the sidestand down and the gearbox in neutral. When starting the engine with a gear engaged, pull in the clutch lever (in this case the sidestand must be in the raised position).

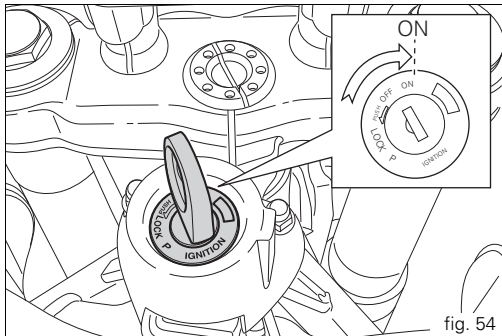



fig. 54

- 2) Check that the stop switch (1, fig. 55) is positioned to  (RUN), then press the starter button (2).



### Note

If the battery is flat, the system automatically disables operation of the starter motor.



### Important

Do not rev the engine when cold. Allow some time for the oil to warm up and reach all points that need lubricating.

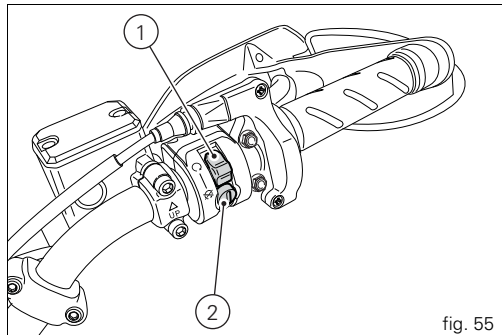

fig. 55

## E Moving off

- 1) Disengage the clutch squeezing the control lever.
- 2) Push down on gear change lever sharply with the tip of your foot to engage the first gear.
- 3) Speed up the engine by turning the throttle twistgrip while gradually releasing the clutch lever; the motorcycle will start moving off.
- 4) Let go of clutch lever and speed up.
- 5) To shift up, close the throttle to slow down engine, disengage the clutch, lift the gear change lever and let go of clutch lever.

To change down, proceed as follows: release the twistgrip, pull the clutch lever, increase engine speed for a moment to allow the gears to synchronise, shift down and release the clutch.

Use the controls intelligently and promptly: when riding uphill do not hesitate to shift down as soon as the motorcycle tends to slow down, so you will avoid stressing the engine and the motorcycle abnormally.

## Important

Avoid sudden acceleration, as this may lead to misfiring and transmission snatching. The clutch lever should not be pulled longer than necessary after gear is engaged, otherwise friction parts may overheat and wear out.

## Braking

Slow down in time, change down to use the engine brake, then apply both brakes. Pull the clutch lever before stopping the motorcycle, to avoid sudden engine stop.



## Warning

Use both brake lever and pedal for effective braking. Never use the brake controls harshly or suddenly as you may lock the wheels and lose control of the motorcycle. When riding in the rain or on slippery surfaces, braking capacity is significantly reduced. Always use the brakes very gently and carefully when riding under these conditions. Any sudden manoeuvres may lead to loss of control. When tackling long, high-gradient downhill road tracts, shift down gears to use engine braking. Apply one brake at a time and use brakes sparingly. Keeping the brakes applied continuously causes the friction material to overheat and dangerously reduces braking effectiveness. Under-inflated or over-inflated tyres reduce braking efficiency and may adversely affect safe riding and road-holding on bends.

## Stopping the motorcycle

Reduce speed, shift down and release the throttle twistgrip. Change down to engage first gear and then neutral. Apply the brakes and bring the motorcycle to a complete stop. To switch the engine off, simply turn the key to OFF (page 45).

## Parking

Stop the motorcycle, then put it on the side stand (see page 57).

To prevent theft, turn the handlebar fully left and turn the ignition key to the LOCK position.

If you park in a garage or other indoor area, make sure that there is proper ventilation and that the motorcycle is not near a source of heat.

You may leave the parking lights on by turning the key to position P.



## Important

Do not leave the key turned to P for long periods or the battery will run down. Never leave the motorcycle unattended with the ignition key inserted.



## Warning

The exhaust system might be hot, even after engine is switched off; take special care not to touch exhaust system with any part of your body and do not park the motorcycle next to inflammable material (wood, leaves etc.).



## Warning

Using padlocks or other locks designed to prevent movement of the motorcycle (such as brake disc locks, rear sprocket locks, and so on) is very dangerous, and may impair motorcycle operation and the safety of rider and passenger.

## E Refuelling (fig. 56)

Never overfill the tank when refuelling. The fuel level should always be below the rim of the filler recess.



### Warning

Use low-lead fuel with a minimum octane rating of 95 RON (see "Top-ups" table, page 97).

Be sure there is no fuel trapped in the filler recess.



### Warning (USA version)

Use low-lead fuel with a minimum octane rating of 90 (RON+MON)/2 (see "Top-ups" table, page 97).

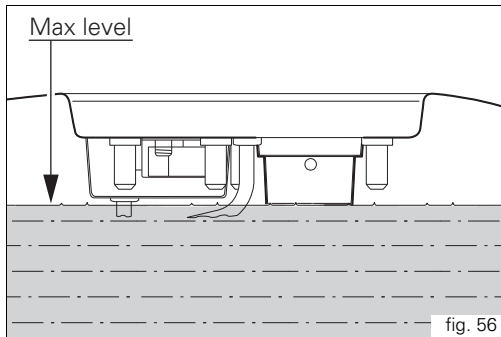

## Tool kit and accessories (fig. 57)

The compartment in the left fairing can be accessed after opening the inner door (see page 56) and contains:

the tool kit, which includes:

- Box wrench for spark plugs;
- Tommy bar for plug wrench;
- Double-tip screwdriver;
- 3-mm Allen wrench;
- 4-mm Allen wrench;
- 5-mm Allen wrench;
- 10/13 open wrench.

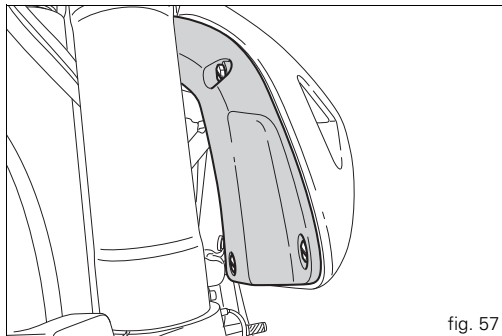

# E Main maintenance operations

## Right side body panel

Lift the seat (page 55).

Remove the fuel tank filler plug (page 54).

Undo the screws (1) and (2) and remove the fuel tank cover (3), withdrawing it towards the seat. recover the washers (4).

## Removing the fairing

Some parts of the motorcycle fairing have to be removed for certain maintenance or repair operations.

### Warning

If parts that have been removed are not refitted correctly they may become loose suddenly while riding and cause you to lose control of your motorcycle.

### Important

At reassembly always fit nylon washers when tightening fastening screws to avoid damage to painted parts and Plexiglas windscreen of headlight fairing.

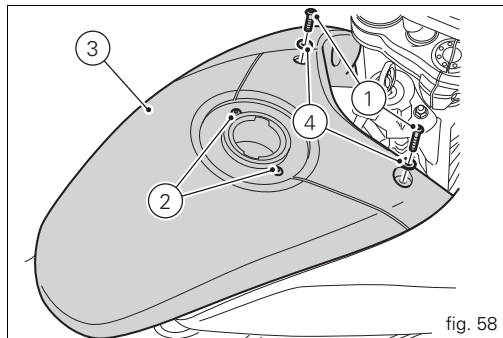
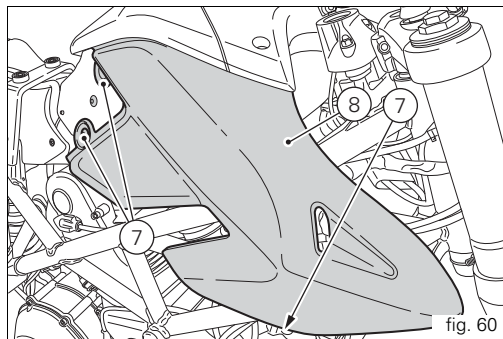
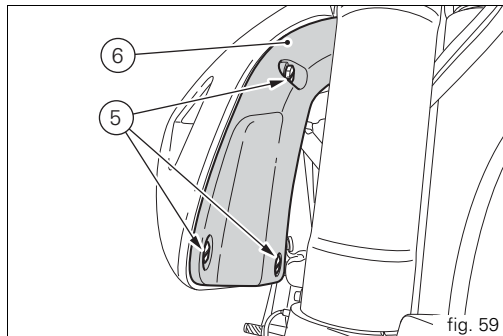

fig. 58

Unscrew the three screws (5) securing the baffle (6).  
Remove the baffle (6).  
Unscrew the three screws (7) and remove the side body panel (8).





## E Checking brake and clutch fluid level

Fluid level should never fall below the MIN mark on each reservoir (fig. 61 and fig. 62).

If level drops below the limit, air can get into the circuit and make the system ineffective.

Brake and clutch fluid must be topped up and changed at the intervals specified in the scheduled maintenance chart reported in the Warranty Card; please contact a Ducati Dealer or authorised Service Centre.

### Important

It is recommended all brake and clutch lines be changed every four years.

### Brake system

If you find excessive play on the brake lever or pedal and the brake pads are still in good condition, contact your Ducati Dealer or authorised Service Centre to have the system inspected and any air drained out of the circuit.

### Warning

Brake and clutch fluid can damage paintwork and plastic parts, so avoid contact. Hydraulic oil is corrosive; it may cause damage and lead to severe injuries. Never mix fluids of different qualities.

Check that the seals are in good condition.

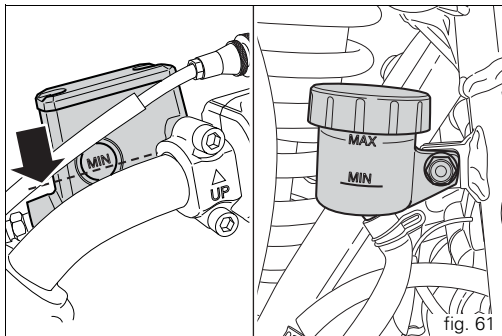

## Clutch system (fig. 62)

If the control lever has excessive play and the transmission snatches or jams when engaging a gear, then there is probably air in the circuit. Contact your Ducati Dealer or authorised Service Centre to have the system inspected and air drained out.



### Warning

The level of clutch fluid tends to increase in the reservoir as the friction material on the clutch plates wears out. Do not exceed the specified level (3 mm above the minimum level).

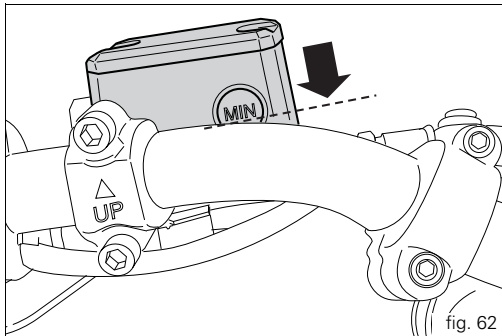

## E Checking brake pads for wear (fig. 63)

Check brake pads wear through the inspection hole in the callipers. Change both pads if friction material thickness of even just one pad is about 1 mm.



### Warning

Friction material wear beyond this limit would lead to metal support contact with the brake disc thus compromising braking efficiency, disc integrity and rider safety.



### Important

Have the brake pads replaced at a Ducati Dealer or authorised Service Centre.

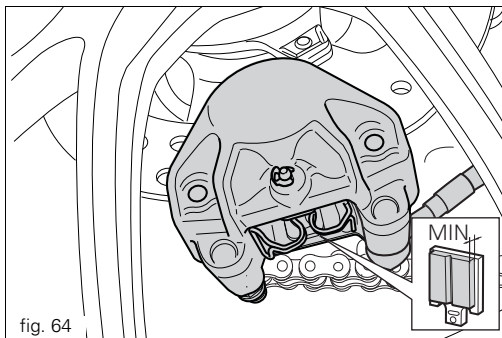
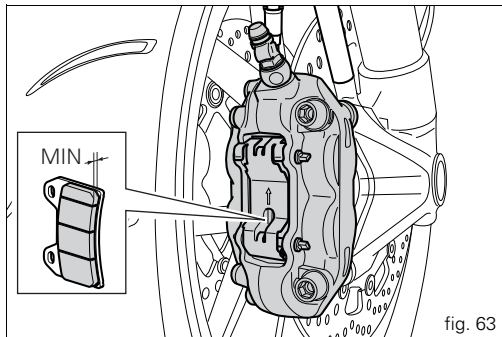

## Lubricating cables and linkages

Check the outer sheath of the throttle control cables for damage at regular intervals. The outer plastic cover should not be flattened or cracked. Work the controls to make sure the cables slide smoothly inside the sheaths: if you feel any friction or catching, have the cable replaced by a Ducati Dealer or Authorised Service Centre.

To prevent these problems, it is advised to open the housing, unscrewing the two fastening screws (1, fig. 65) and then grease the cable end and the pulley.

### Warning

Close the housing carefully, inserting the cable in the pulley.

Refit the housing and tighten the screws (1) to 1.8 Nm.

To ensure smooth operation of side stand joint, clean off any dirt and apply SHELL Alvania R3 grease at all points exposed to friction (1, fig. 66).

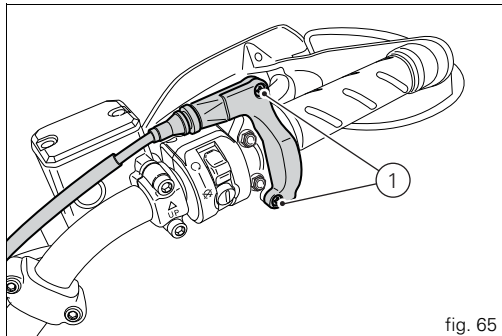

fig. 65

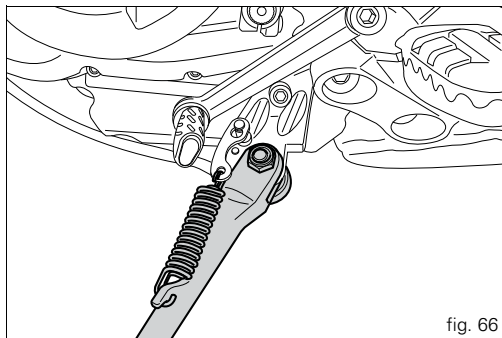

fig. 66

## Throttle cable adjustment (fig. 67)

The throttle twistgrip must have 2 to 4 mm of free travel, measured at the outer edge of the twistgrip housing.

If necessary, adjust it using the adjuster (1) on the control.

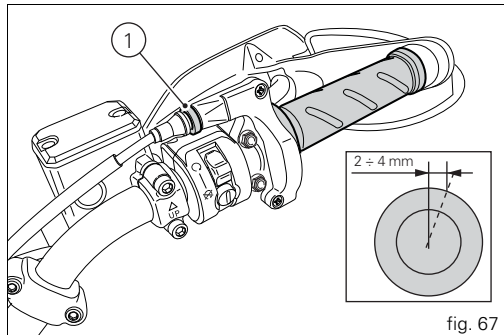

fig. 67

## Charging the battery (fig. 68)

Before charging the battery, it is best to remove it from the motorcycle.

Remove the seat (see page 55). Disconnect the black negative terminal (-) and the red positive terminal (+) in the order.

Unscrew the two screws (1) securing the battery brackets and remove the battery from the battery compartment.

### Warning

Batteries develop explosive gases: keep it away from heat sources.

Charge the battery in a ventilated room.

Connect the red battery charger lead to the positive (+) terminal on the battery, the black lead to the negative (-) terminal.

### Important

Always connect up the battery before switching the battery charger on: failure to do so can result in sparking at the battery terminals, which could ignite the gases inside the cells.

Always connect the red positive (+) terminal first.

Reinstall the battery on its support and secure the brackets with the screws (1). Connect the terminals. Use some grease on the fastening screws to improve conductivity.

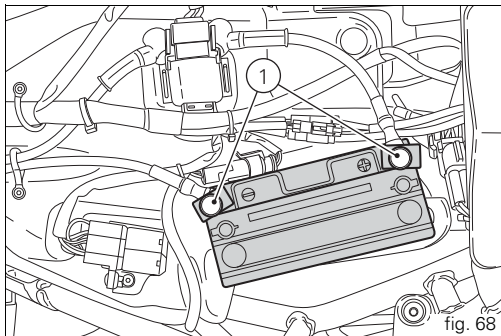

### Warning

Keep the battery out of the reach of children.

Charge the battery at 0.9 A for 5÷10 hours.

## E Checking drive chain tension (fig. 69)

Slowly move the motorcycle to determine the position at which the chain is most taut.

Place the motorcycle on the side stand and check, in the front part (forward facing) of the lower chain guard, press the chain downward and then release it, tension up until the distance between the aluminium section of the swingarm and the chain pin centre is between  $37 \div 39$  mm, as shown on the label on the swingarm.

### Important

Have chain tension adjusted by a Ducati Dealer or authorised Service Centre.

### Warning

Correct tightening of swinging arm screws (1, fig. 70) is critical to rider and passenger safety.

### Important

Improper chain tension will lead to early wear of transmission parts.

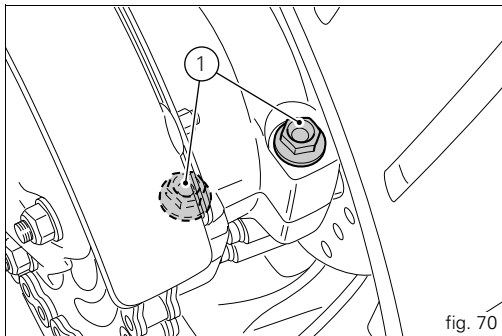
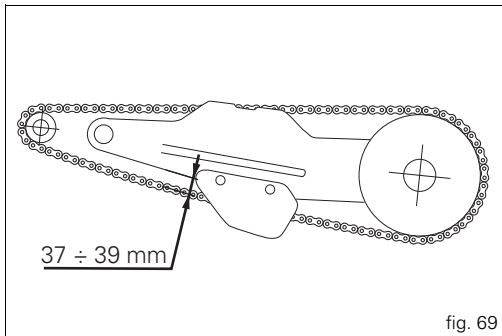

## Lubricating the drive chain

The chain fitted on your motorcycle has O-rings to protect its moving parts from dirt, and to hold the lubricant inside.

The seals might be irreparably damaged if the chain is cleaned using any solvent other than those specific for O-ring chains or washed using steam or water cleaners.

After cleaning, blow the chain dry or dry it using absorbent material and apply SHELL Advance Chain or Advance Teflon Chain on each link.



### Important

Using non-specific lubricants may cause severe damage to the chain and the front and rear sprocket.



## Replacing the headlight bulbs

Before replacing a burnt-out bulb, make sure that the new bulb complies with the voltage and wattage specified in the "Wiring diagram", page 103. Always test the new bulb before refitting any parts you have removed.

Unscrew the screws (1) with an Allen wrench.

Ease off the headlight support towards the front until releasing the twistgrip (2).

Unscrew the twistgrip (2) turning counter clockwise.

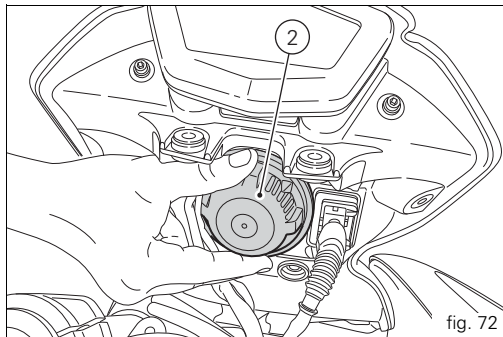
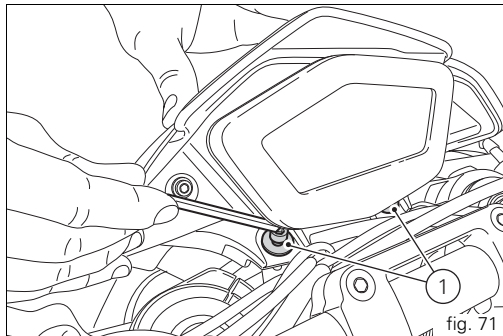

Release the clip (3).

The bulb (4) has a bayonet base: press and twist counter clockwise to remove. Push in the new bulb and turn it clockwise until it clicks into place.



### Note

Be careful to hold the new bulb at the base only. Never touch the transparent body with your fingers or it will blacken resulting in reduced bulb brilliancy.

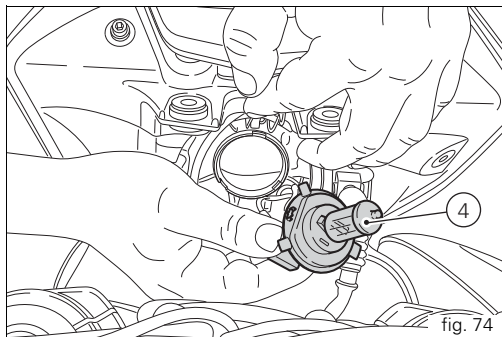
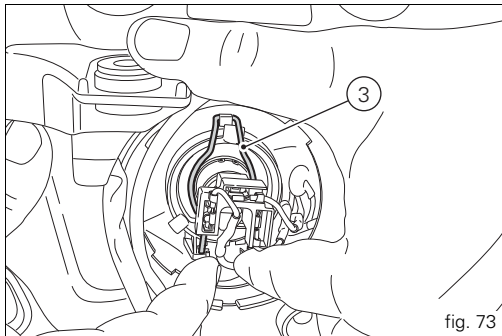

## E Changing the rear turn indicator bulbs

To change the rear turn indicator bulbs, loosen the screw (1) and remove the cup (2).

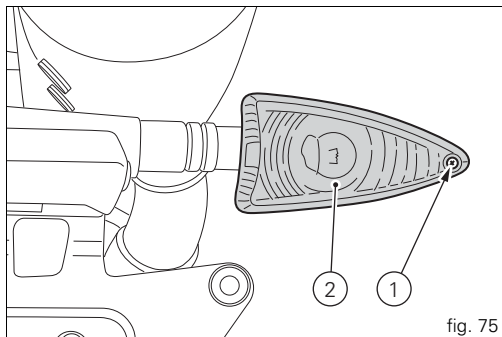

## Replacing the number plate light bulbs

Remove the grommet (1) and extract the bulb.

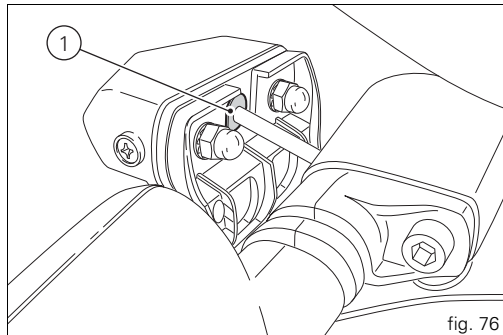

E

## E Beam setting (fig. 77)

To check the headlight aim, place the motorcycle upright with the tyres inflated to the correct pressure and one person sitting astride the motorcycle. The motorcycle should be perfectly vertical, with its longitudinal axis at right angles to a wall or screen at a distance of 10 metres. Draw a horizontal line at the height of the centre of the headlamp and a vertical one at the longitudinal axis of the motorcycle.

If possible, perform this check in dim light.

Switch on the low beam headlight.

The height of the light spot (measured at the upper limit between dark and lighted-up area) should not exceed  $\frac{9}{10}$ th of the height from ground of headlamp centre.



### Note

This is the procedure specified by Italian regulations for checking the maximum height of the light beam.

Owners in other countries should adapt this procedure to the regulations in force in the country where the motorcycle is used.

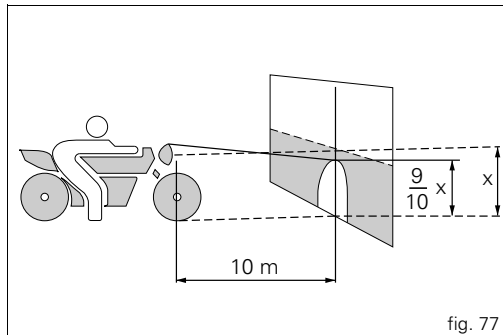

fig. 77

## Beam adjustment (fig. 78 and fig. 79)

Unscrew the screws (1) with an Allen wrench, and ease off the headlight support towards the front until gaining access to headlight adjusters.

Turn the screw (2) to set beam height.

Turn the screw (3) to set beam height.

### Important

The adjusting screws (2) and (3) have no end stop.

### Warning

The headlight might fog up if the vehicle is used when raining or after washing.

Switch the headlight on for a short time to dry up any condensate.

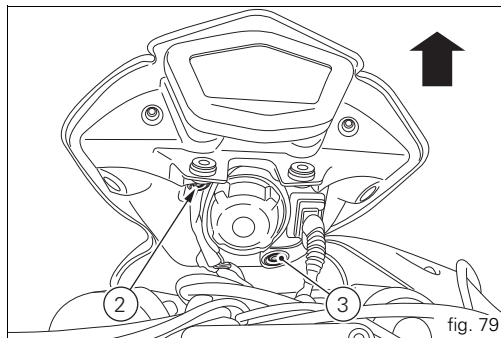
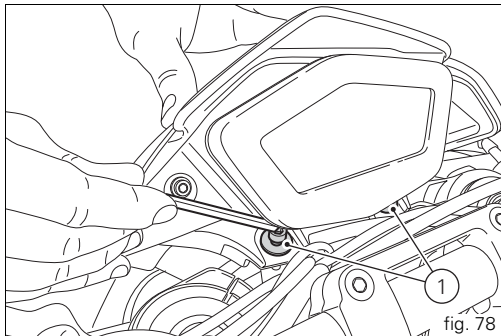

## Tubeless tyres

Front tyre pressure:

2.2 bar

Rear tyre pressure:

2.2 bar



### Note

To ride with a passenger, increase rear tyre pressure to 2.4 bar.

As tyre pressure is affected by changes in temperature and altitude; check and adjust them whenever you are riding in areas where there are large variations in temperature or altitude.



### Important

Check and adjust the pressures with the tyres cold. To avoid front wheel rim distortion, when riding on bumpy roads, increase front tyre pressure by 0.2 - 0.3 bar.

## Tyre repair or change (Tubeless tyres)

With minor punctures, tubeless tyres take a long time to deflate, as they tend to hold the air inside. If you find low pressure on one tyre, check the tyre for punctures.



### Warning

Punctured tyres must be replaced. Replace with tyres of the original brand and type. Be sure to tighten the valve dust caps securely to prevent leaks while riding. Never fit tyres with inner tubes, as these can cause the tyre to burst suddenly, with possibly serious consequences for the rider and passenger.

After replacing a tyre, the wheel must be balanced.



### Important

Do not remove or alter the position of the wheel balancing weights.



### Note

Have the tyres replaced at a Ducati Dealer or authorised Service Centre. Correct removal and installation of the wheels is essential.

## Minimum tread depth

Measure tread depth (S, fig. 80) at the point where tread is most worn down.

It should not be less than 2 mm, and in any case not less than the legal limit.



### Important

Visually inspect the tyres at regular intervals for cracks and cuts, especially on the side walls, and bulges or large stains that indicate internal damage. Replace them if badly damaged.

Remove any stones or other foreign bodies stuck in the tread.

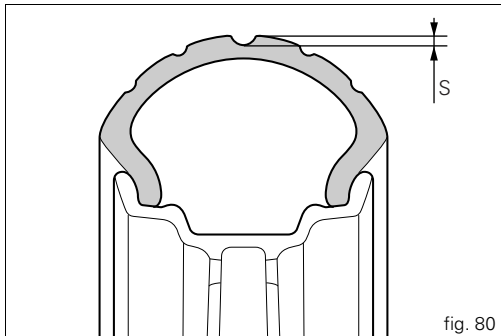



## Checking engine oil level (fig. 81)

Engine oil level can be checked through the sight window (1) on the clutch cover on the RH side of the engine. When checking oil level, the motorcycle should be perfectly upright and the engine cold. Oil level should be between the marks near the sight glass. If level is low, top up with SHELL Advance 4T Ultra engine oil. Remove the filler plug (2) and top up to correct level. Replace the filler cap.

### Important

Engine oil and oil filters must be changed by a Ducati Dealer or authorised Service Centre at the intervals specified in the scheduled maintenance chart reported in the Warranty Card.

### Oil viscosity

SAE 15W-50

The other viscosity degrees indicated in the table can be used if the local average temperature is within the limits specified for that oil viscosity.

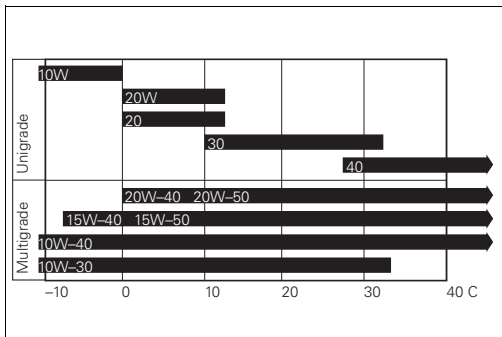
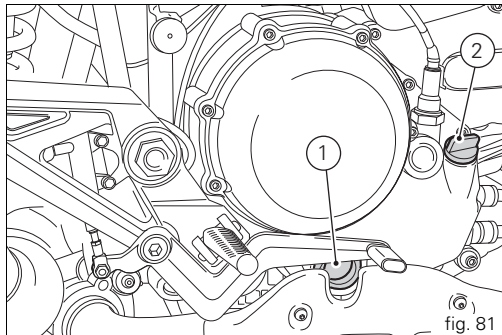

## Cleaning and replacing the spark plugs (fig. 82)

Spark plugs are an important part of the engine and should be checked at regular intervals.

Spark plug condition provides a good measure of engine condition.

Have the spark plugs inspected or replaced at a Ducati Dealer or Authorised Service Centre; they will check the colour of the ceramic insulator of the central electrode: an even brown colour is a sign that the engine is in good running order.

They will also inspect the centre electrode for wear and check spark plug gap, which should be:

0.7 - 0.8 mm.



### Important

A gap outside the specified limits will adversely affect engine performance and may lead to difficult starting or erratic idling.

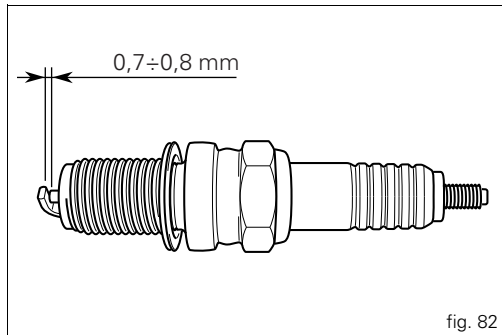

## E General cleaning

To preserve the original shine on metal surfaces and paintwork, wash and clean your motorcycle at regular intervals depending on the type of use and according to the particular road conditions. Use specific products, where possible biodegradable. Avoid aggressive detergents or solvents.

Only use water and neutral soap to clean the Plexiglas and the seat.

Clean the aluminium components regularly and by hand. Use specific detergents for aluminium that do NOT contain abrasive substances or caustic soda.



### Note

Do not use abrasive or steel wool sponges, use only a soft cloth.

The warranty does not apply to motorcycles where there is evidence of poor maintenance.



### Important

Do not wash your motorcycle immediately after use, as marks can form due to evaporation of the water on hot surfaces. Never clean the motorcycle using hot or high-pressure water jets. Cleaning the motorcycle with a high pressure water jet may lead to seizure or serious faults in the front fork, wheel hub assembly, electric system, headlight (fogging), front fork seals, air inlets or exhaust silencers, with consequent loss of safety.

If parts of the engine are unusually dirty or greasy, use a degreasing agent, avoiding contact with transmission components (chain, front and rear sprockets, etc.). Rinse with warm water and dry all surfaces with chamois leather.



### Warning

There may be loss of braking efficiency immediately after washing the motorcycle. Never grease or lubricate the brake discs as this would cause loss of braking effectiveness. Clean the discs with an oil-free solvent.



### Warning

The headlight might fog up due to washing, rain or moisture. Switch headlight on for a short time to dry up any condensate.

## Storing the motorcycle

If the motorcycle is to be left unused for a long period, it is advisable to carry out the following operations first:

clean the motorcycle;

empty the fuel tank;

pour a few drops of engine oil into the cylinders through the spark plug seats, then crank the engine by hand a few times so a protective film of oil will spread on cylinder inner walls;

place the motorcycle on a service stand;

disconnect and remove the battery.

Battery should be checked and charged (or replaced, as required) whenever the motorcycle has been left unriden for over a month.

Protect the motorcycle with the special cover available from Ducati Performance that will not damage the paintwork or retain moisture.

## Important notes

The legislation in some countries (France, Germany, Great Britain, Switzerland, etc.) sets certain noise and pollution standards.

Periodically carry out the required checks and replace parts as necessary, using Ducati original spare parts, in compliance with the regulations in the country concerned.

# Maintenance

Programmed maintenance plan: operations to be carried out by the dealer

List of operations and type of intervention [set mileage (km/mi) or time interval *]	Km. x1000	1	12	24	36	48	60
	mi. x1000	0.6	7.5	15	22.5	30	37.5
	Months	6	12	24	36	48	60
Change the engine oil		●	●	●	●	●	●
Change the engine oil filter		●	●	●	●	●	●
Clean the engine oil pick-up filter					●		
Check engine oil pressure				●		●	
Check/adjust the valve clearances (1)			●	●	●	●	●
Check the tension of the timing belts (1)			●		●		●
Replace the timing belts				●		●	
Check and clean the spark plugs. Replace if necessary				●		●	
Check and clean air filter (1)			●		●		●

List of operations and type of intervention [set mileage (km/mi) or time interval *]	Km. x1000	1	12	24	36	48	60
	mi. x1000	0.6	7.5	15	22.5	30	37.5
	Months	6	12	24	36	48	60
Change the air filter				●		●	
Check throttle body synchronisation and idling (1)			●	●	●	●	●
Check the brake and clutch fluid levels		●	●	●	●	●	●
Change the clutch and brake fluid					●		
Check and adjust the brake and clutch control cables			●	●	●	●	●
Check/lubricate throttle / cold start controls			●	●	●	●	●
Check tyre pressure and wear		●	●	●	●	●	●
Check the brake pads. Change, if necessary.		●	●	●	●	●	●
Check the steering head bearings				●		●	
Check the drive chain tension, alignment and lubrication		●	●	●	●	●	●
Check the clutch disc pack. Change, if necessary (1)			●	●	●	●	●
Check the rear wheel cush drive				●		●	
Check the wheel hub bearings				●		●	
Check the indicators and lighting			●	●	●	●	●
Check tightness of nuts and screw securing the engine to the frame			●	●	●	●	●
Check the sidestand			●	●	●	●	●
Check tightness of the front wheel axle nut			●	●	●	●	●
Check tightness of the rear wheel axle nut			●	●	●	●	●
Check the external fuel hoses			●	●	●	●	●

List of operations and type of intervention [set mileage (km/mi) or time interval *]	Km. x1000	1	12	24	36	48	60
	mi. x1000	0.6	7.5	15	22.5	30	37.5
	Months	6	12	24	36	48	60
Change the front fork fluid					●		
Check the forks and rear shock absorber for oil leaks			●	●	●	●	●
Check the front sprocket retaining bolts			●	●	●	●	●
General lubrication and greasing			●	●	●	●	●
Check and recharge the battery			●	●	●	●	●
Road test the motorcycle		●	●	●	●	●	●
General cleaning			●	●	●	●	●

\* Service on the set interval, whichever comes first (mileage or months)

(1) Operation to be performed only if set mileage (km/mi) is reached

## Programmed maintenance plan: operations to be carried out by the customer

List of operations and type of intervention [set mileage (km/mi) or time interval *]	Km. x1000	1
	mi. x1000	0.6
	Months	6
Checking the engine oil level		●
Check the brake and clutch fluid levels		●
Check tyre pressure and wear		●
Check the drive chain tension and lubrication		●
Check the brake pads. If necessary, contact your dealer to replace pads		●

\* Service on the set interval, whichever comes first (mileage or months)



# Technical data

Overall dimensions (mm) (fig. 83)

## Weights

In running order without fluids and battery:

167 kg.

Dry weight in running order without fuel:

178.2 kg.

Fully laden:

390 kg.

## Warning

Failure to observe weight limits could result in poor handling and impair the performance of your motorcycle, and could result in loss of control.

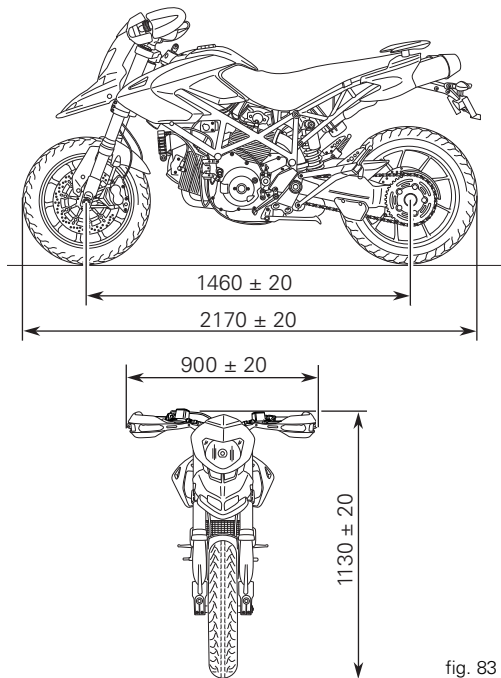

fig. 83

TOP-UPS	TYPE	CU DM (LITRES)
Fuel tank, including a reserve of 3.3 dm <sup>3</sup> (litres)	Unleaded fuel with RON 95 fuel octane rating (at least). For USA version use unleaded fuel with at least 90 fuel octane (RON+MON)/2.	12.4
Lubrication circuit	SHELL - Advance 4T Ultra	3.4
Front/rear brake and clutch circuits	Special hydraulic fluid SHELL Advance Brake Dot 4	—
Protection for electrical contacts	SHELL - Advance Contact Cleaner spray for electric systems	—
Front fork	SHELL - Advance Fork 7.5 or Donax TA	450 cc (right leg) 470 cc (left leg)



### Important

Do not use additives in fuel or lubricants.

## Engine

90 degree twin cylinder four stroke, Desmodromic valve gear, electronic fuel injection, air cooled.

Bore, mm:

88

Stroke, mm:

66

Total displacement, cu. cm:

803

Compression ratio:

$11 \pm 0.5:1$

Max. power at crankshaft (95/1/EC):

81 kW – 60 HP at 8000 rpm

Max torque at crankshaft (95/1/EC):

76 Nm - 7.7 kgm at 6250 rpm

## Important

Do not exceed the specified rpm limits in any running conditions.

## Timing system

DESMODROMIC (type) with two valves per cylinder, operated by four rockers (2 opening rockers and 2 closing rockers) and one overhead camshaft. It is operated by the crankshaft through spur gears, belt rollers and toothed belts.

## Desmodromic timing system (fig. 84)

- 1) Opening (or upper) rocker.
- 2) Opening rocker shim.
- 3) Split rings.
- 4) Closing (or lower) rocker shim.
- 5) Return spring for lower rocker.
- 6) Closing (or lower) rocker.
- 7) Camshaft.
- 8) Valve.

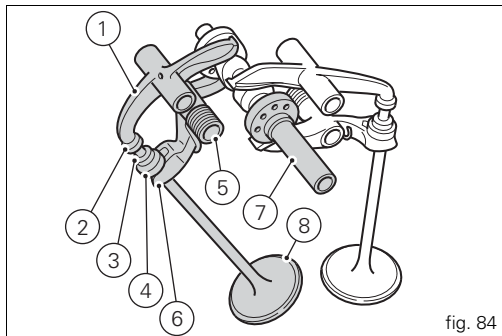

fig. 84

## Performance data

Maximum speed in any gear should be reached only after the correct running-in period with the motorcycle properly serviced at the recommended intervals.

## Spark plugs

The ignition system uses two spark plugs per cylinder. This twin-spark ignition system provides optimised combustion and enhanced power, and especially benefits midrange performance.

Make:

NGK

Type:

DCPR8E

alternative

Make:

CHAMPION

Type:

RA4 HC

## Fuel system

MARELLI indirect electronic fuel injection.

Throttle body diameter:

45 mm

Injectors per cylinder: 1

Holes per injector: 8

Fuel supply: 95-98 RON.



## Warning (USA version)

Use a min. number of 90 octane (RON+MON)/2.

## Exhaust system

Equipped with catalytic converter.

## Transmission

The clutch drum and plates are made entirely from special aluminium alloy.

Wet clutch controlled by the lever on left-hand side of the handlebar.

Transmission from engine to gearbox input shaft via spur gears.

Front sprocket/clutch sprocket ratio:

33/61

6-speed gearbox with constant mesh gears, gear change pedal on left side of motorcycle.

Final drive ratio:

15/41

Total gear ratios:

1<sup>st</sup> gear 13/32

2<sup>nd</sup> gear 18/30

3<sup>rd</sup> gear 21/28

4<sup>th</sup> gear 23/26

5<sup>th</sup> gear 22/22

6<sup>th</sup> gear 26/24

Drive transmitted from gearbox to rear wheel via chain:

Make:

DID

Type:

525 HV2

Dimensions:

5/8" x 5/16"

Number of links:

104



### Important

The above gear ratios are approved and should not be modified under any circumstances.

However, if you wish to tune up your motorcycle for competitions or special tracks, Ducati Motor Holding S.p.A. will be pleased to provide information about the special ratios available. please contact a Ducati Dealer or Authorised Service Centre.



### Warning

If the rear sprocket needs replacing, contact a Ducati Dealer or authorised Service Center. If improperly replaced, this component could seriously endanger your safety and that of your passenger, and cause irreparable damage to your motorcycle.

## Brakes

### Front

Semi-floating drilled twin-disc.

Carrier material:  
aluminium.

Braking material:  
steel.

Disc diameter:  
305 mm.

Hydraulically operated by a control lever on right handlebar.

Braking surface:  
84 cm<sup>2</sup>.

Brake caliper make:  
BREMBO

Type:  
P4.32K - 4 pistons.

Friction material:  
FERIT I/D 450FF

Master cylinder type:  
PS16/22 Adjustable levers.

### Rear

With fixed drilled disc.

Carrier material:  
steel.

Braking material:  
steel.

Disc diameter:  
245 mm.

Hydraulically operated by pedal on right side.

Braking surface:  
25 cm<sup>2</sup>.

Make:  
BREMBO

Type:  
P34c-2 pistons

Friction material:  
FERIT I/D 450 FF.

Master cylinder type:  
PS 11.



### Warning

Brake fluid can dissolve paintwork and can cause severe eye and skin injuries in the event of accidental spilling. Wash the affected area with abundant running water.

## Frame

High-strength tubular steel trellis frame.

Steering angle (on each side):

30.5°

Steering geometry is as follows:

Steering head angle:

24°

Trail:

102 mm

## Wheels

### Front

Five spoke light alloy front wheel rim.

Dimensions:

MT3.50x17".

### Rear

Light alloy, five spokes.

Dimensions:

MT5.50x17".

The front wheel is mounted on a removable axle. The rear wheel is cantilever mounted on the hub at the rear of the single-sided swingarm.

## Tyres

### Front

Radial tubeless tyre.

Size:

120/70-ZR17

### Rear

Radial tubeless tyre.

Size:

180/55-ZR17

## Suspension

### Front

Hydraulic upside-down fork.

Stanchion diameter:

43 mm.

Travel along fork leg axis:

165 mm

### Rear

Of the progressive type, thanks to a rocker arm connecting frame and upper pivot point of the shock absorber.

The shock absorber is adjustable for rebound and spring preload. At the bottom pivot point it is connected to a light-alloy single-sided swingarm. The swinging arm rotates around a pivot shaft that passes through frame and engine.

The whole system gives the bike excellent stability.

Shock absorber stroke:

59.5 mm.

Wheel travel:

135 mm

## Colour schemes

Ducati Anniversary red 473.101 (PPG);

Clear lacquer 228.880 (PPG);

Red frame and black rims.

Pearl white Streetfighter code L2909004 (LECHLER) + primer code L0050786 (LECHLER);  
Clear lacquer, code 92311281 (PALINI);  
black frame and black rims.

Matt black code 291.501 (PPG);  
black frame and black rims.

## Electric system

The main components of the electric system are:

HEADLIGHT:

One-bulb H4 (12V - 55W / 60W).

Parking lights W3W (12V - 3W).

ELECTRICAL CONTROLS on handlebars.

FRONT TURN INDICATORS, led.

REAR TURN INDICATORS, 12V - 3W bulbs.

HORN.

BRAKE LIGHT SWITCHES.

BATTERY dry, 12V - 10 Ah.

Generator 12V-480W.

ELECTRONIC REGULATOR.

STARTER MOTOR Denso 12V - 0.7kW.

Tail light, led.



### Note

For bulb replacement instructions, please read the relevant paragraphs from page 80 onwards.



## Fuses

Electrical parts are protected by six fuses housed inside special fuse boxes.

Refer to the table to identify their use and amperage.

### KEY TO THE FUSEBOX

Pos.	El. item	Rating
1	Key on, solenoid starter, lambda sensor and stop	10 A
2	Lights	15 A
3	Loads	15 A
4	Injection	20 A
5	ECU	5 A
6	Instrument panel	5 A
7	DDA and battery recharge	5 A

The main fuse box (1, fig. 85) is located under the right side body panel (see page 70). Remove the protective cover to access the fuses.

Besides the fuse box, a master fuse (2) positioned on the solenoid starter under the seat in front of battery.

Remove caps to expose fuses (2, fig. 86).

A blown fuse is identified by the interrupted centre link (3, fig. 87).

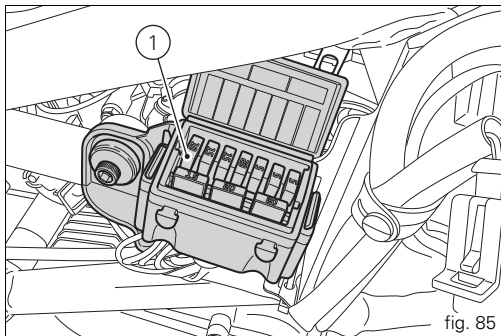

fig. 85

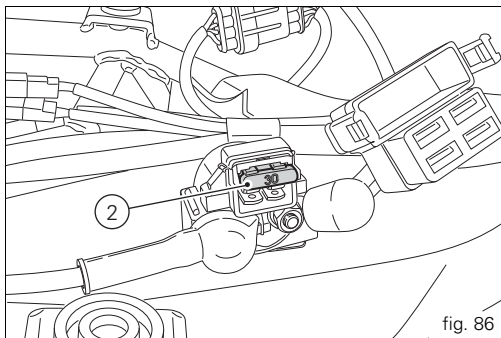

fig. 86



### Important

Switch the ignition key to OFF before replacing the fuse to avoid possible short circuits.



### Warning

Never use a fuse with a rating other than that specified. Failure to observe this rule may damage the electric system or even cause fire.

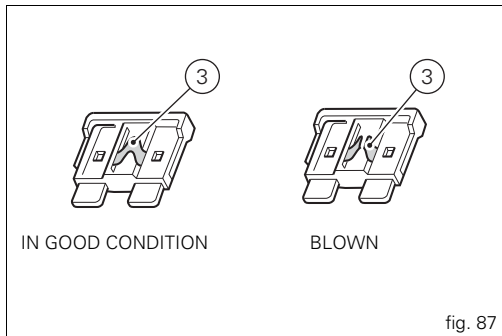

## Injection /electric system diagram key

- 1) Right-hand handlebar switch
- 2) Immobilizer antenna
- 3) Ignition switch
- 4) Fuse box
- 5) Data acquisition / diagnosis
- 6) Starter motor
- 7) Solenoid starter with MASTER fuse
- 8) Battery
- 9) Engine ground / System ground
- 10) Regulator
- 11) Generator
- 12) Tail light
- 13) RH rear turn indicator
- 14) Number plate light
- 15) LH rear turn indicator
- 16) Fuel tank
- 17) Injection relay
- 18) Speed sensor
- 19) Side stand switch
- 20) Air temperature sensor
- 21) MAP pressure sensor
- 22) Vertical lambda sensor
- 23) Horizontal lambda sensor
- 24) Horizontal cylinder coil
- 25) Horizontal cylinder spark plug, RH side
- 26) Vertical cylinder coil
- 27) Vertical cylinder spark plug, RH side
- 28) Horizontal cylinder injector
- 29) Vertical cylinder injector
- 30) Throttle position sensor
- 31) Timing/rpm sensor
- 32) Oil temperature sensor (control unit)
- 33) Stepper motor
- 34) Neutral switch
- 35) Oil pressure switch
- 36) Rear stop switch
- 37) Front stop switch
- 38) Clutch switch
- 39) Left-hand handlebar switch
- 40) Drain valve motor (not present on HYM 796)
- 41) Instrument panel
- 42) LH front turn indicator
- 43) Horn
- 44) Headlight
- 45) RH front turn indicator
- 46) ECU

## Wire colour coding

- B** Blue
- W** White
- V** Violet
- Bk** Black
- Y** Yellow
- R** Red
- Lb** Light blue
- Gr** Grey
- G** Green
- Bn** Brown
- O** Orange
- P** Pink



### Note

The electric system wiring diagram is at the end of this manual.

## Routine maintenance record

KM	DUCATI SERVICE	MILEAGE	DATE
1000			
12000			
24000			
36000			
48000			
60000			

# For United States of America version Only

## Reporting of safety defects

If you believe that your vehicle has a defect which could cause a crash or could cause injury or death, you should immediately inform the National Highway Traffic Safety Administration (NHTSA) in addition to notifying Ducati North America. If NHTSA receives similar complaints, it may open an investigation, and if it finds that a safety defect exists in a group of vehicles, it may order a recall and remedy campaign. However, NHTSA cannot become involved in individual problems between you, your dealer, or Ducati North America. To contact NHTSA, you may either call the Auto Safety Hotline toll-free at 1-800-424-9393 (or 366-0123 in Washington, D.C. area) or write to: NHTSA, 1200 New Jersey Avenue SE W43-488, Washington, D.C. 20590. You can also obtain other information about motor vehicle safety from the Hotline.

## Safety warnings

Traffic Rules vary from jurisdiction to jurisdiction. Know the regulations in your jurisdiction before riding this motorcycle.



### Warning

This motorcycle is designed and intended for use on streets and other smooth, paved areas only. Do not use this motorcycle on unpaved surfaces. Such use could lead to upset or other accident.

## Noise emission warranty

Ducati Motor S.p.A. warrants that this exhaust system, at the time of sale, meets all applicable U.S. EPA Federal noise standards. This warranty extends to the first person who buys this exhaust system for purposes other than resale, and to all subsequent buyers. Warranty claims should be directed to: Ducati North America, 10443 Bandlely Drive, Cupertino, California, 95014  
Tel: 001.408.253.0499 - Fax: 001.408.253.4099.

## Noise and exhaust emission control system information

### Source of Emissions

The combustion process produces carbon monoxide and hydrocarbons. Control of hydrocarbons is very important because under certain conditions, they react to form photochemical smog when subjected to sunlight.

Carbon monoxide does not react in the same way, but is toxic. Ducati utilizes lean carburetor settings and other systems to reduce carbon monoxide and hydrocarbons.

## Exhaust Emission Control System

The Exhaust Emission Control System is composed of lean carburetor settings, and no adjustments should be made except idle speed adjustments with the throttle stop screw. The Exhaust Emission Control System is separate from the crankcase emission control system.

## Crankcase Emission Control System

The engine is equipped with a closed crankcase system to prevent discharging crankcase emissions into the atmosphere. Blow-by gas is returned to the combustion chamber through the air cleaner and the throttle body.

### Evaporative Emission Control System

California motorcycles are equipped with an evaporative emission control system which consists of a charcoal canister and associated piping. This system prevents the escape of fuel vapors from the throttle body and fuel tank.

## Tampering warning

Tampering with Noise Control System Prohibited. Federal Law prohibits the following acts or causing thereof:

(1) the removal or rendering inoperative by any person, other than for purposes of maintenance, repair, or replacement, of any device or element of design incorporated into any new vehicle for the purpose of noise control prior to its sale or delivery to the ultimate purchaser or while it is in use; or

(2) the use of the vehicle after such device or element of design has been removed or rendered inoperative by any person.

Among those acts presumed to constitute tampering are the acts listed below:

- (1) Removal of, or puncturing the muffler, baffles, header pipes or any other component which conducts exhaust gases.
- (2) Removal or puncturing of any part of the intake system.
- (3) Lack of proper maintenance.
- (4) Replacing any moving part of the vehicle, or parts of the exhaust or intake system, with parts other than those specified by the manufacturer.

This product should be checked for repair or replacement if the motorcycle noise has increased significantly through use. Otherwise, the owner may become subject to penalties under state and local ordinances.

## Problems that may affect motorcycle emissions

If you are aware of any of the following symptoms, have the vehicle inspected and repaired by your local Ducati dealer.

Symptoms:

Hard starting or stalling after starting.

Rough idle.

Misfiring or backfiring during acceleration.

After-burning (backfiring).

Poor performance (driveability) and poor economy.

## Riding safety

The points given below are applicable for every day motorcycle use and should be carefully observed for safe and effective vehicle operation.

A motorcycle does not provide the impact protection of an automobile, so defensive riding in addition to wearing protective apparel is extremely important.

Do not let protective apparel give you a false sense of security.

Before changing lanes, look over your shoulder to make sure the way is clear. Do not rely solely on the rear view mirror; you may misjudge a vehicle's distance and speed, or you may not see it at all.

When going up steep slopes, shift to a lower gear so that there is plenty of power to spare rather than overloading the engine.

When applying the brakes, use both the front and rear brakes. Applying only one brake for sudden braking may cause the motorcycle to skid and lose control.

When going down long slopes, control vehicle speed by closing the throttle. Use the front and rear brakes for auxiliary braking.

Riding at the proper rate of speed and avoiding unnecessarily fast acceleration are important not only for safety and low fuel consumption but also for long vehicle life and quieter operation.

When riding in wet conditions or on loose roadway surfaces, the ability to maneuver will be reduced. All of your actions should be smooth under these conditions. Sudden acceleration, braking or turning may cause loss of control.

When the roadway is wet, rely more on the throttle to control vehicle speed and less on the front and rear brakes.

The throttle should also be used judiciously to avoid skidding the rear wheel from too rapid acceleration or deceleration.

On rough roads, exercise caution, slow down, and grip the fuel tank with your knees for better stability.

When quick acceleration is necessary as in passing, shift to a lower gear to obtain the necessary power.

Do not down shift at too high an r.p.m. to avoid damage to the engine from overrevving.

Avoiding unnecessary weaving is important to the safety of both the rider and other motorists.

Do not exceed the legal speed limit or drive too fast for existing conditions. High speed increases the influence of any condition affecting stability and the loss of control.

Operate motorcycle only at moderate speed and out of traffic until you have become thoroughly familiar with its operation and handling characteristics under all conditions. This is a very high performance motorcycle, designed and intended for use by experienced careful riders only!

A new motorcycle must be operated according to a special break-in procedure (see Running in recommendations).



### Warning

Before starting engine, check for proper operation of brake, clutch, shifter, throttle controls, correct fuel and oil supply.

Gasoline is extremely flammable and is explosive under certain conditions. Refuel in a well ventilated area with the engine stopped. Do not smoke or allow open flames or sparks when refuelling or servicing the fuel system.



Always close the fuel petcock when the engine is not running to prevent flooding of the throttle body. Do not overfill fuel tank (see instructions page 55).

Motorcycle exhaust contains poisonous carbon monoxide gas. Do not inhale exhaust gases and never run the engine in a closed garage or confined area.

Use only Ducati approved parts and accessories.

This motorcycle was not intended to be equipped with a sidecar or to be used to tow any trailer or other vehicle.

Ducati does not manufacture sidecars or trailers and cannot predict the effects of such accessories on handling or stability, but can only warn that the effects will be adverse and any damage to motorcycle components caused by the use of such accessories will not be remedied under warranty.



### Warning

Do not ride the motorcycle with helmets attached to the hook; the helmets could cause an accident by distracting the operator or interfering with normal vehicle operation.

### Protective apparel

Always wear a helmet. Most motorcycle accident fatalities are due to head injuries.

For safety eye protection, gloves, and high top, sturdy boots should also be worn.

The exhaust system becomes very hot during operation, never touch the exhaust system. Wear clothing that fully covers your legs. Do not wear loose clothing which could catch on the control levers, footrests, wheels, or chain.

Any amount of alcohol will significantly interfere with your ability to safely operate your motorcycle. Don't drink and ride.

### Vehicle identification number (VIN);

Every Ducati motorcycle is identified by two identification numbers (see page 10). fig. A specifically shows the frame identification numbers.

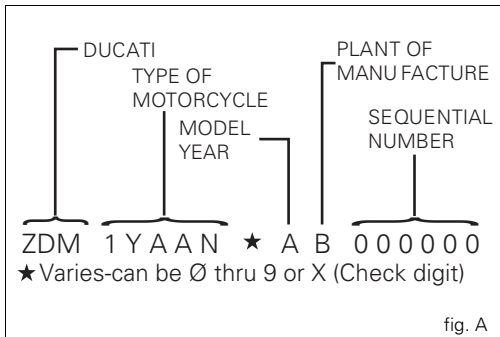

fig. A

Label location (fig. B)

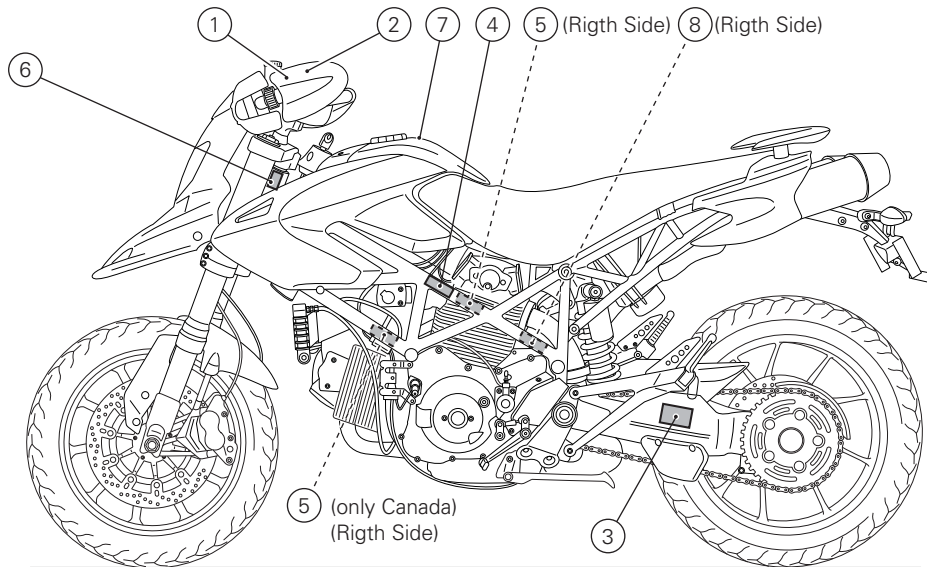

fig. B

OBJECTS IN MIRROR ARE  
CLOSER THAN THEY APPEAR

1

**WARNING**  
DO NOT ATTEMPT TO LOOK THROUGH THIS FAIRING. THIS IS NOT A WINDSHIELD, BUT AN AERODYNAMIC FAIRING ONLY. FAILURE TO OBSERVE THIS WARNING COULD RESULT IN A COLLISION OR UPSET AND CONSEQUENT SERIOUS BODILY INJURY. 044.001.1.004

2

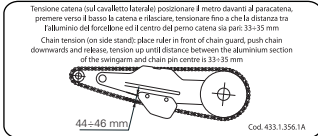

3

### MOTORCYCLE NOISE EMISSION CONTROL INFORMATION

THIS [ ] MOTORCYCLE ZDM [ ] MEETS EPA NOISE EMISSION REQUIREMENTS OF [ ] dB(A) AT [ ] RPM BY THE FEDERAL TEST PROCEDURE. MODIFICATIONS WHICH CAUSE THIS MOTORCYCLE TO EXCEED FEDERAL NOISE STANDARDS ARE PROHIBITED BY FEDERAL LAW. SEE OWNER'S MANUAL

432.1.593.1A

MANUFACTURED BY: **DUCATI MOTORHOLDING spa**

DATE: [ ]/[ ]/[ ]

GVWR: [ ] Lbs ( [ ] kg)  
GAWR F: [ ] Lbs ( [ ] kg) with [ ] tire, [ ] rim at [ ] PSI cold  
GAWR R: [ ] Lbs ( [ ] kg) with [ ] tire, [ ] rim, at [ ] PSI cold

THIS VEHICLE CONFORMS TO ALL APPLICABLE FEDERAL MOTOR VEHICLE STANDARDS IN EFFECT ON THE DATE OF MANUFACTURE SHOW ABOVE.

TYPE CLASSIFICATION: MOTORCYCLE

VEHICLE I.D. No. ZDM [ ]

432.1.593.1B

4

MANUFACTURED BY/FABRIQUÉ PAR : **DUCATI MOTORHOLDING spa**  
TYPE OF VEHICLE / TYPE DE VÉHICULE : MC DATE: [ ]/[ ]/[ ]  
GVWR / PNBV: XXX KG. V.I.N. / N.I.V. : ZDM [ ]

GAWR PNEU RD	TIRE/PNEU - DIMENSION - RIM/JANTE	COLD INFL. PRESS. PRESS. DE SOUS-P. A FROID P.SI/L.P.C. EPA
max	max	max
min	min	min

THIS VEHICLE CONFORMS TO ALL APPLICABLE STANDARDS PRESCRIBED UNDER THE CANADIAN MOTOR VEHICLE SAFETY REGULATIONS IN EFFECT ON THE DATE OF MANUFACTURE.  
CE VÉHICULE EST CONFORME À TOUTES LES NORMES QUI LUI SONT APPLICABLES EN VERTU DU RÈGLEMENT SUR LA SÉCURITÉ DES VÉHICULES AUTOMOBILES DU CANADA EN VIGUEUR À LA DATE DE SA FABRICATION.

432.1.593.1F

5 (Only Canada)

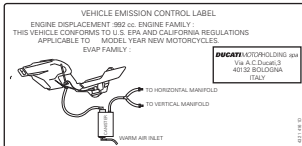

8

### VEHICLE EMISSION CONTROL INFORMATION

Engine displacement: [ ] cc  
Engine family: [ ]  
Engine exhaust control system: [ ]

THIS VEHICLE CONFORMS TO U.S. EPA REGULATIONS APPLICABLE TO [ ] MODEL YEAR NEW MOTORCYCLES

### ENGINE TUNE-UP SPECIFICATIONS

ITEM	SPECIFICATIONS	INSTRUCTIONS
IGNITION TIMING:	[ ] BTDC at 500 speed	No adjustment
IDLE SPEED (RPM):	[ ] min	No adjustment
IDLE MIXTURE:	Opening [ ] mm	No adjustment
VALVE CLEARANCE (in & ex):	Closing [ ] mm	See Service Manual
SPARK PLUG: CHAMPION [ ]		
SPARK PLUG GAP (mm): [ ]		

OIL: [ ]  
FUEL: Unleaded gasoline

**DUCATI MOTORHOLDING spa** - BOLOGNA - ITALY

6

**CAUTION**  
NEVER FILL TANK SO FUEL LEVEL RISES INTO FILLER NECK. IF TANK IS OVERFILLED, HEAT MAY CAUSE FUEL TO EXPAND AND FLOW INTO EVAPORATIVE EMISSION CONTROL SYSTEM RESULTING IN HARD STARTING AND ENGINE HESITATION.

7

## California emission control warranty statement

### Your warranty rights and obligations

The California Air Resources Board is pleased to explain the emission control system warranty on your MY 2012 motorcycle. In California, new motor vehicles must be designated, built and equipped to meet the State's stringent anti-smog standards. Ducati North America, Inc. must warrant the emission control system on your motorcycle for the periods of time listed below provided there has been no abuse, neglect or improper maintenance of your motorcycle. Your emission control system may include parts such as fuel-injection system, the ignition system, catalytic converter, and engine computer. Also included may be hoses, belts, connectors and other emission-related assemblies. Where a warrantable condition exists, Ducati North America, Inc. will repair your motorcycle at no cost to you including diagnosis, parts and labor.

## Manufacturer's warranty coverage

- 5 years or 30,000 kilometers (18641 miles), whichever first occurs.

## Owner's warranty responsibilities:

- As the motorcycle owner, you are responsible for the performance of the required maintenance listed in your owner's manual. Ducati North America, Inc. recommends that you retain all receipts covering maintenance on your motorcycle, but Ducati North America, Inc. cannot deny warranty solely for the lack of receipts or for your failure to ensure the performance of all scheduled maintenance.
- You are responsible for presenting your motorcycle to a Ducati dealer as soon as a problem exists. The warranty repairs should be completed in a reasonable amount of time, not to exceed 30 days.
- As the motorcycle owner, you should also be aware that Ducati North America, Inc. may deny you warranty coverage if your motorcycle or a part has failed due to abuse, neglect, improper maintenance or unapproved modifications.

If you have any questions regarding your warranty rights and responsibilities, you should contact Ducati North America, Inc. at 001.408.253.0499 or the California Air Resource Board at 9528 Telstar Avenue, El Monte, CA 91731.

## California evaporation emission system

This system consists of (fig. C):

- 1) Warm air inlet;
- 2) Canister;
- 3) Dell'Orto jet;
- 4) Intake manifolds;
- 5) Breather pipe;
- 6) Fuel tank.

### Important

In the event of fuel system malfunction, contact Ducati's authorized Service Centres.

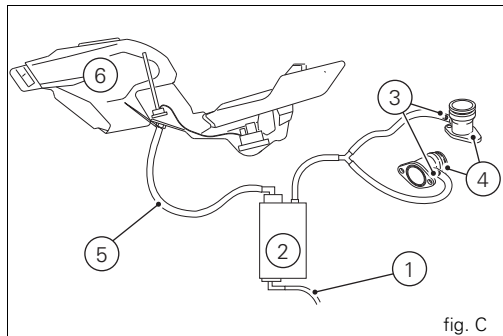

fig. C

## Ducati limited warranty on emission control system

Ducati North America, Inc., 10443 Bandlely Drive Cupertino, California, 95014 warrants that each new 1998 and later Ducati motorcycle, that includes as standard equipment a headlight, tail-light and stoplight, and is street legal:

A) is designed, built and equipped so as to conform at the time of initial retail purchase with all applicable regulations of the United States Environmental Protection Agency, and the California Air Resources Board; and

B) is free from defects in material and workmanship which cause such motorcycle to fail to conform with applicable regulations of the United States Environmental Protection Agency or the California Air Resources Board for a period of use of 30,000 kilometers (18,641 miles) or 5 (five) years from the date of initial retail delivery, whichever first occurs.

### I. Coverage

Warranty defects shall be remedied during customary business hours at any authorized Ducati motorcycle dealer located within the United States of America in compliance with the Clean Air Act and applicable regulations of the United States Environmental Protection Agency and the California Air Resources Board. Any part or parts replaced under this warranty shall become the property of Ducati.

In the state of California only, emissions related warranted parts are specifically defined by that state's Emissions Warranty Parts List. These warranted parts are: carburetor and internal parts; intake manifold; fuel tank, fuel injection system; spark advance mechanism; crankcase breather; air cutoff valves; fuel tank cap for evaporative emission controlled vehicles; oil filler cap; pressure control valve; fuel/vapor separator; canister; igniters; breaker governors; ignition coils; ignition wires; ignition points, condensers, and spark plugs if failure occurs prior to the first scheduled replacement, and hoses, clamps, fittings and tubing used directly in these parts. Since emission related parts may vary from model to model, certain models may not contain all of these parts and certain models may contain functionally equivalent parts.

In the state of California only, Emission Control System emergency repairs, as provided for in the California Administrative Code, may be performed by other than an authorized Ducati dealer. An emergency situation occurs when an authorized Ducati dealer is not reasonably available, a part is not available within 30 days, or a repair is not complete within 30 days. Any replacement part can be used in an emergency repair. Ducati will reimburse the owner for the expenses, including diagnosis, not to exceed Ducati's suggested retail price for all warranted parts replaced and labor charges based on Ducati's recommended time allowance for the warranty repair and the geographically appropriate hourly labor rate. The owner may be required to keep receipts and failed parts in order to receive compensation.

## II. Limitations

This Emission Control System Warranty shall not cover any of the following:

- A. Repair or replacement required as a result of
  - (1) accident,
  - (2) misuse,
  - (3) repairs improperly performed or replacements improperly installed,
  - (4) use of replacement parts or accessories not conforming to Ducati specifications which adversely affect performance and/or
  - (5) use in competitive racing or related events.
- B. Inspections, replacement of parts and other services and adjustments required for routine maintenance.
- C. Any motorcycle on which odometer mileage has been changed so that actual mileage cannot be readily determined.

## III. Limited liability

A. The liability of Ducati under this Emission Control Systems Warranty is limited solely to the remedying of defects in material or workmanship by an authorized Ducati motorcycle dealer at its place of business during customary business hours. This warranty does not cover inconvenience or loss of use of the motorcycle or transportation of the motorcycle to or from the Ducati dealer. Ducati shall not be liable for any other expenses, loss or damage, whether direct, incidental, consequential or exemplary arising in connection with the sale or use of or inability to use the Ducati motorcycle for any purpose. Some states do not allow the exclusion or limitation of any incidental or consequential damages, so the above limitations may not apply to you.

B. No express emission control system warranty is given by Ducati except as specifically set forth herein. Any emission control system warranty implied by law, including any warranty of merchantability or fitness for a particular purpose, is limited to the express emission control systems warranty terms stated in this warranty. The foregoing statements of warranty are exclusive and in lieu of all other remedies. Some states do not allow limitations on how long an implied warranty lasts so the above limitation may not apply to you.

C. No dealer is authorized to modify this Ducati Limited Emission Control Systems Warranty.

#### IV. Legal rights

This warranty gives you specific legal rights, and you may also have other rights which vary from state to state.

V. This warranty is in addition to the Ducati limited motorcycle warranty.

#### VI. Additional information

Any replacement part that is equivalent in performance and durability may be used in the performance of any maintenance or repairs. However, Ducati is not liable for these parts. The owner is responsible for the performance of all required maintenance. Such maintenance may be performed at a service establishment or by any individual. The warranty period begins on the date the motorcycle is delivered to an ultimate purchaser.

Ducati North America, Inc..  
10443 Bandlely Drive  
Cupertino, California, 95014  
Tel: 001.408.253.0499  
Fax: 001.408.253.4099  
E-mail: [customerservice@ducatiusa.com](mailto:customerservice@ducatiusa.com)  
Web site: [www.ducatiusa.com](http://www.ducatiusa.com)

# Routine maintenance record

KM	MI	DUCATI SERVICE NAME	MILEAGE	DATE
1,000	600			
12,000	7,500			
24,000	15,000			
36,000	22,500			
48,000	30,000			
60,000	37,500			



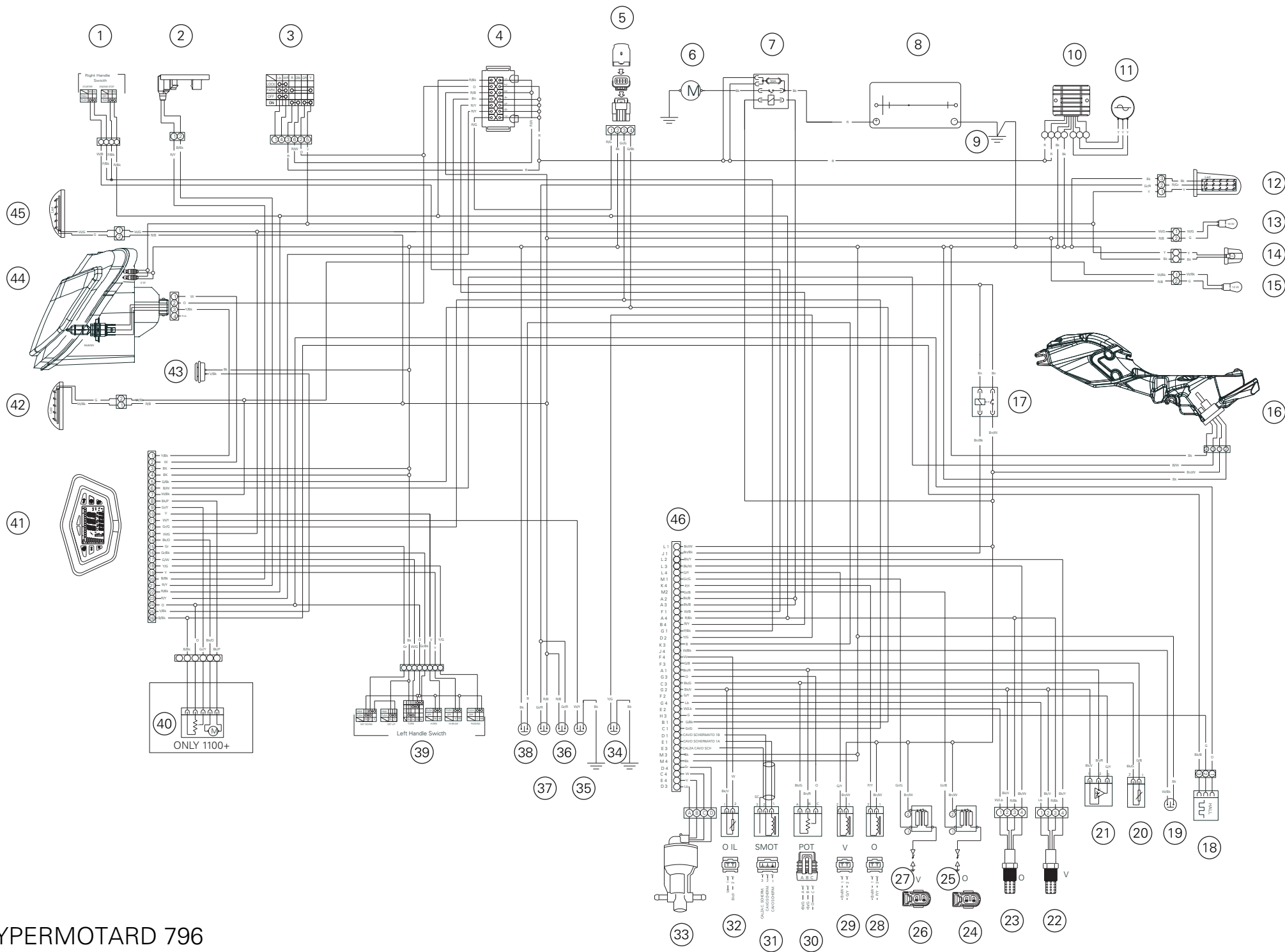

Stampato 11/2011

Cod. 913.7.146.1M

Ducati Motor Holding spa  
[www.ducati.com](http://www.ducati.com)

Via Cavalieri Ducati, 3  
40132 Bologna, Italia  
Tel. +39 051 6413111  
Fax +39 051 406580

cod 913.7146.1M