

Owner's manual
Manual de uso y mantenimiento
Manuel d'utilisation et entretien
オーナーズマニュアル

SUPERBIKE

***848^{EVO} CORSE
SPECIAL EDITION***



SUPERBIKE

***848^{EVO} CORSE
SPECIAL EDITION***

We would like to welcome you among Ducati enthusiasts, and congratulate you on your excellent choice of motorcycle. We think you will ride your Ducati motorcycle for long journeys as well as short daily trips. Ducati Motor Holding S.p.A. wishes you smooth and enjoyable riding.

We are continuously working to improve our Technical Assistance service. For this reason, we recommend that you strictly follow the instructions in this manual, especially those regarding the running-in period. In this way, you can be sure your Ducati motorcycle will continue to be a pleasure to ride.

For any servicing or suggestions you might need, please contact our authorised service centres.

We also provide an information service for all Ducati owners and enthusiasts for any advice and suggestions you might need.

Enjoy your ride!



Note

Ducati Motor Holding S.p.A. cannot accept any liability for errors that may have occurred in the preparation of this manual. All information in this manual is valid at the time of going to print. Ducati Motor Holding S.p.A. reserves the right to make any modifications required due to the ongoing development of their products.

For your safety, as well as to preserve the warranty, reliability and worth of your motorcycle, use original Ducati spare parts only.



Warning

This manual forms an integral part of the motorcycle and - if the motorcycle is resold - must always be handed over to the new owner.

E Table of contents

General Indications 7

- Warranty 7
- Symbols 8
- Useful information for safe riding 8
- Carrying the maximum load allowed 9
- Identification data 10

Instrument panel (Dashboard) 11

- Instrument panel 11
- LCD unit functions 14
- LCD – How to set/display parameters 16
- Total distance covered indicator: "Odometer" 18
- Air temperature indicator 19
- Vehicle speed indication 20
- Engine coolant temperature indicator 21
- Trip meter "TRIP A" 22
- Trip meter "TRIP B" 23
- Distance travelled on fuel reserve: "TRIP FUEL" 24
- Service indicator (SERV) 25

- Battery voltage indicator (BATT) 26
- Engine idle RPM setting (RPM) 27
- LAP timer 28
- Stored data display (LAP Memory) 30
- DDA data acquisition 31
- Erase DDA 32
- Function for activation / deactivation of DTC (Ducati Traction Control) 33
- Description of the system 33
- Activation of the system 34
- The functions of the system 34
- Routine maintenance 34
- DTC (Ducati Traction Control) setting function 35
- Tips on how to select the sensitivity level 37
- Tips for use on the track 38
- Tips for use on the road 38
- Quick Shift (DQS ON/OFF) enable / disable function 39
- Clock setting function 40
- Instrument panel diagnostics 41
- Instrument panel backlighting 46
- Headlight "smart" auto-off 46
- Headlight "smart" SWITCH-ON 46
- The Immobilizer system 47
- Keys 47
- Code Card 48
- Immobilizer override procedure 49
- Operation 51
- Duplicate keys 51
- Service menu - unit of measurement (UNIT SET) 52

Controls 54

- Position of motorcycle controls 54
- Key-operated ignition switch and steering lock 55
- LH switch 56
- Clutch lever 57
- RH switch 58
- Throttle twistgrip 58
- Front brake lever 59
- Rear brake pedal 60
- Gear change pedal 60
- Setting the gear change and rear brake pedals 61

Main components and devices 63

- Position on the vehicle 63
- Fuel tank plug 64
- Seat lock 65
- Side stand 66
- Steering damper 67
- Front fork adjusters 68
- Rear shock absorber adjusters 70

Riding the motorcycle 72

- Running-in recommendations 72
- Pre-ride checks 74
- Starting the engine 75
- Moving off 77
- Braking 77
- Stopping the motorcycle 78
- Parking 78

- Refuelling 79
- Tool kit and accessories 80

Main maintenance operations 81

- Removing the fairing 81
- Changing the air filter 85
- Checking and topping up coolant level 86
- Checking brake and clutch fluid level 87
- Checking brake pads for wear 89
- Lubricating cables and joints 90
- Adjusting throttle control free play 91
- Charging the battery 92
- Checking drive chain tension 93
- Chain lubrication 94
- Replacing the high and low beam bulbs 95
- Replacing the parking light bulb 97
- Rear turn indicators 98
- Number plate light 98
- Beam setting 99
- Rear-view mirror adjustment 100
- Tubeless tyres 101
- Checking engine oil level 103
- Cleaning and replacing the spark plugs 104
- Cleaning the motorcycle 105
- Storing the bike away 106
- Important notes 106

Maintenance 107

- Scheduled maintenance chart: operations to be performed by the dealer 107

E Scheduled maintenance chart: operations to be performed
by the customer 110

Technical data 111

Overall dimensions (mm) 111

Weights 111

Engine 113

Timing system 113

Performance data 114

Spark plugs 114

Fuel system 114

Brakes 115

Transmission 116

Frame 117

Wheels 117

Tyres 117

Suspensions 118

Exhaust system 119

Available colours 119

Electrical system 119

Routine maintenance record 124

For United States of America version
Only 125

Routine maintenance record 135

General Indications



Warning

The vehicle is only compatible with fuel having a maximum content of ethanol of 10% (E10). Using fuel with ethanol content over 10% is forbidden. Using them could result in severe damage of the engine and motorcycle components. Using fuel with ethanol content over 10% will make the warranty null and void.

E

Warranty

In your own interest, and in order to guarantee product reliability, you are strongly advised to refer to our authorised Dealers and Service Centers for any servicing requiring particular technical expertise.

Our highly skilled staff have access to the implements required to perform any servicing job at best, and use Ducati original spare parts only as the best guarantee for full interchangeability, smooth running and long life.

All Ducati motorcycles come with a "Warranty Card". However, warranty does not apply to the motorcycles used in competitions or competitive trials or whenever poor maintenance status is ascertained. No motorcycle part may be tampered with, altered, or replaced with parts other than original Ducati spare parts during the warranty period, or the warranty right will be automatically invalidated.

Symbols

Ducati Motor Holding S.p.A. advises you to read this manual carefully in order to become familiar with your motorcycle. In case of any doubts, please call a Dealer or authorised Service Center. The information contained herein will prove useful on your trips - and Ducati Motor Holding S.p.A. wishes you smooth, enjoyable riding - and will help you keep the performance of your motorcycle unchanged for a long time. This manual contains some special remarks:



Warning

Failure to comply with these instructions may put you at risk and lead to severe injury or death.



Important

Possibility of damaging the motorcycle and/or its components.



Note

Additional information concerning the job being carried out.

The terms RIGHT and LEFT are referred to the motorcycle viewed from the riding position.

Useful information for safe riding



Warning

Read this section before riding your motorcycle.

Accidents are frequently due to inexperience. Always make sure you have your licence with you when riding; you need a valid licence to be entitled to ride your motorcycle.

Do not lend your motorcycle to inexperienced riders or who do not hold a valid licence.

Both rider and pillion passenger must ALWAYS wear a safety helmet.

Wear proper clothing, with no loose items or accessories that may become tangled in the controls or limit your zone of vision.

Never start or run the engine indoors. Exhaust gases are poisonous and may lead to loss of consciousness or even death within a short time.

Both rider and pillion passenger should keep their feet on the footpegs when the motorcycle is in motion.

ALWAYS hold the handlebars firmly with both hands so you will be ready for sudden changes of direction or in the road surface. The pillion passenger should ALWAYS hold on to the strap onto passenger seat with both hands.

Ride within the law and observe national and local rules. ALWAYS respect speed limits where these are posted.

However, ALWAYS adjust your speed to the visibility, road and traffic conditions you are riding in.

ALWAYS signal your intention to turn or pull to the next lane in good time using the suitable turn indicators.

Be sure you are clearly visible and do not ride within the blind spot of vehicles ahead.

Be very careful when tackling road junctions, or when riding in the areas near exits from private grounds, car parks or on slip roads to access motorways.

ALWAYS turn off the engine when refuelling.

Be extremely careful not to spill fuel on the engine or on the exhaust pipe when refuelling.

Do not smoke when refuelling.

While refuelling, you may inhale noxious fuel vapours.

Should any fuel drops be spilled on your skin or clothing, immediately wash with soap and water and change your clothing.

ALWAYS remove the key when you leave your motorcycle unattended.

The engine, exhaust pipes, and silencers stay hot for a long time.



Warning

The exhaust system might be hot, even after engine is switched off; pay particular attention not to touch exhaust system with any body part and do not park the vehicle next to inflammable material (wood, leaves etc.).

Park your motorcycle where no one is likely to hit it and use the side stand.

Never park on uneven or soft ground or your motorcycle may fall over.

Carrying the maximum load allowed

Your motorcycle is designed for long-distance riding, carrying the maximum load allowed in full safety.

Even weight distribution is critical to preserving these safety features and avoiding trouble when performing sudden manoeuvres or riding on bumpy roads.

Information about carrying capacity

The total weight of the motorcycle in running order including rider, passenger, luggage and additional accessories should not exceed:

390 kg.

Arrange your luggage or heavy accessories in the lowest possible position and close to motorcycle centre.

Be sure to secure the luggage to the supports provided on the motorcycle as firmly as possible. Improperly secured luggage may affect stability.

Never fix bulky or heavy objects to the handlebar or to the front mudguard as this would affect stability and cause danger.

Do not insert any objects you may need to carry into the gaps of the frame as these may foul moving parts.

Make sure the tyres are inflated to the proper pressure indicated on page 101 and that they are in good condition.

Identification data

All Ducati motorcycles have two identification numbers, for frame (fig. 1) and engine (fig. 2).

Frame number

Engine number



Note

These numbers identify the motorcycle model and should always be indicated when ordering spare parts.

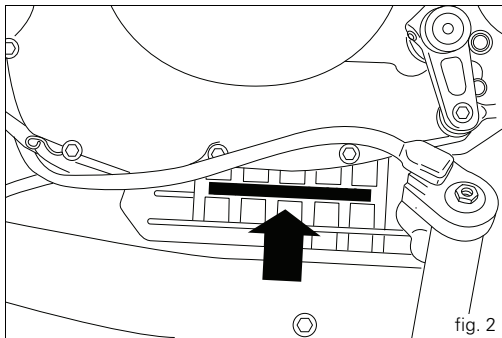
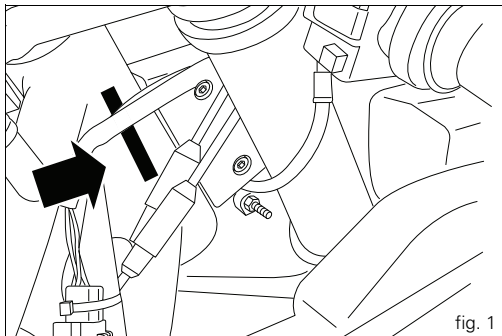

Instrument panel (Dashboard)

Instrument panel

1) LCD, (SEE PAGE 14)

2) REVOLUTION COUNTER (rpm).

Shows the engine rotation speed/minute (rpm).

3) NEUTRAL LIGHT N (GREEN).

Comes on when in neutral position.

4) LOW FUEL LIGHT  (YELLOW).

Comes on when fuel is low and there are about 3 litres of fuel left in the tank.

5) TURN INDICATOR LIGHTS  (GREEN).

Illuminates and flashes when the turn indicator is in operation.

6) ENGINE OIL PRESSURE LIGHT  (RED).

Comes on when engine oil pressure is too low. It briefly comes on when the ignition is switched to ON and normally goes out a few seconds after engine starts.

It may shortly come on when the engine is hot, however, it should go out as the engine revs up.

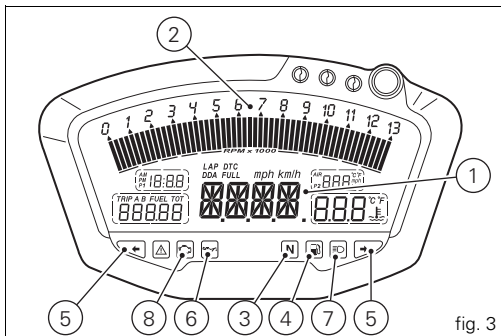

fig. 3



Important

If this light (6) stays on, stop the engine or it may suffer severe damage.

7) HIGH BEAM LIGHT  (BLUE).

Comes on when high beam is on.

8) "ENGINE DIAGNOSIS- EOBd" LIGHT  (AMBER YELLOW).

The engine ECU illuminates this light to indicate errors and consequent engine lock.

9) "VEHICLE DIAGNOSIS" LIGHT

Illuminates when the motorcycle diagnostics detects a problem.

10) LIMITER LIGHT - OVER REV

Light 10A: This light comes on steady at 800 rpm below the limiter threshold.

Lights 10A + 10B: These lights come on steady at 400 rpm below the limiter threshold.

Lights 10A + 10B + 10C: They start flashing when the rev limiter is reached.

11) TRACTION CONTROL LIGHT (fig. 6)

Light 11A: with DTC active, this light turns on when a minimal torque reduction is applied.

Lights 11A + 11B: with DTC active, these lights turn on when a low torque reduction is applied.

Lights 11A + 11B + 11C: with DTC active, these lights turn on when a medium torque reduction is applied.

Lights 11A + 11B + 11C + 11D: with DTC active, these lights turn on when a high torque reduction is applied.

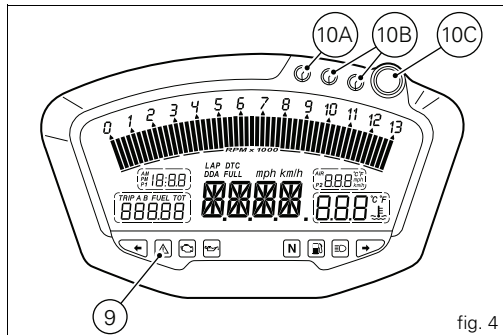

fig. 4

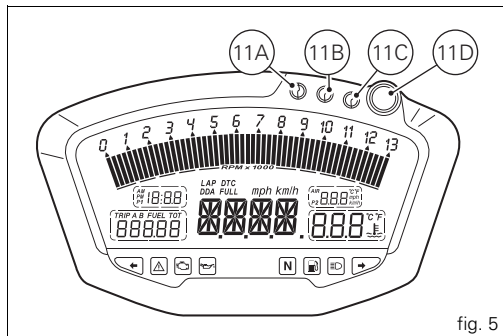

fig. 5

12) CONTROL SWITCH

Button used to display and set instrument panel parameters. It has two positions: A "▲" and B "▼".

13) HIGH-BEAM FLASH BUTTON FLASH (fig. 6)

The high-beam flash button may also be used to control the LAP functions and the instrument panel DDA data logger.

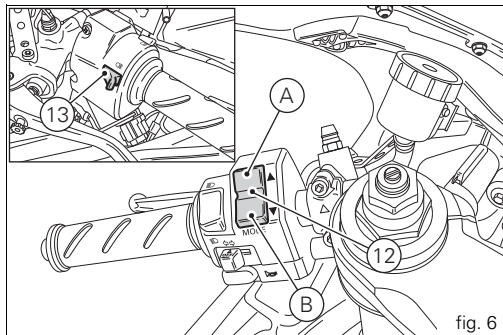

LCD unit functions



Warning

Stop the motorcycle before using the instrument panel controls. Never operate the instrument panel controls while riding.

1) SPEEDOMETER.

Gives road speed

2) ODOMETER.

Gives total distance covered.

3) TRIP METER.

Indicates distance covered since the meters (TRIP A and TRIP B) were last reset.

4) TRIP FUEL METER.

Gives total distance travelled on fuel reserve.

5) CLOCK.

6) LAP TIMER.

7) ENGINE RPM INDICATOR (RPM).

8) LAP TIME, MAXIMUM SPEED AND MAXIMUM RPM RECORDING (LAP).

9) BATTERY VOLTAGE INDICATOR (BATT).

10) AIR TEMPERATURE INDICATOR.

11) WATER TEMPERATURE INDICATOR.

This function indicates engine coolant temperature.



Important

Never use the vehicle when the temperature reaches max. value or the engine might damage.

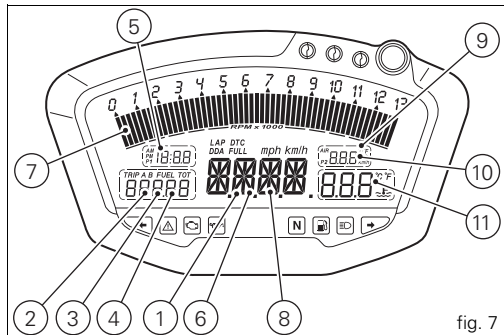

fig. 7

12) SERVICE WARNING (SERV).

The "SERV" message indicates that the vehicle has covered the distance corresponding to a Scheduled Maintenance interval. The message is displayed only at Key-On for 5 seconds. The service indicator will be reset at an authorised Ducati Service Centre during servicing.

13) LAP FUNCTION.

Indicates activation of the LAP function.

14) DDA FUNCTION.

Indicates activation of the DDA function.

15) TRACTION CONTROL (DTC).

Indicates activation of the DTC system control unit.

16) (DQS) FUNCTION.

Indicates activation of the DQS function.

Important

The instrument panel allows the diagnosis of the electronic ignition/injection system. Never use the menus reserved for trained personnel for any reason. If this function is accidentally accessed, turn the key to OFF and contact a Ducati Dealer or Authorised Service Centre for the necessary checks.

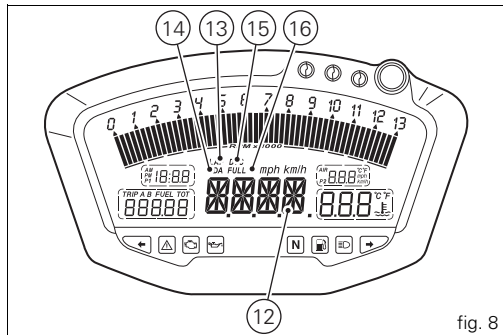

fig. 8

LCD – How to set/display parameters

At key-on (key turned from OFF to ON) the instrument panel activates all the digits of the LCD for 1 second and switches on the indicator lights in sequence.

It then switches to "normal" display mode showing the model indication in place of the road speed readout and the version (EU, UK, USA, CND, FRA, JAP) for 2 seconds.

Model is displayed as "scrolling" text until the engine is started.

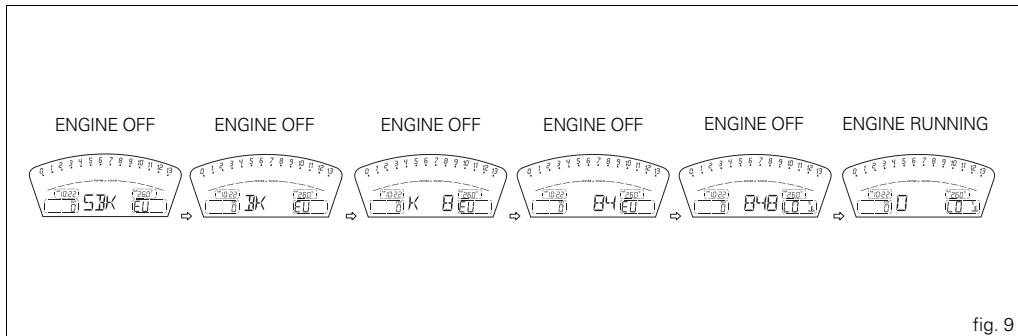

fig. 9

At Key-On, the instrument panel always shows the following information (de-activating any previously activated functions):

ODOMETER
AIR TEMPERATURE
CLOCK
SPEED
COOLANT TEMPERATURE
ENGINE RPM

With the switch (12, fig. 6) in position B “▼” the Odometer readout (TOT) will cycle through the following functions:

TRIP A
TRIP B
TRIP FUEL (only if active)
DTC (available only if Traction Control is fitted and active)
until cycling back to the ODOMETER (TOT) function.

Pressing switch (12, fig. 6) in position A “▲” gives access to the MENU and the following functions are displayed one after another:

ERROR (only if at least one error is present)
BATT
RPM
LAP (OFF or ON)
LAP MEM
DDA (OFF or ON)
DTC OFF/ON (active on vehicle with Traction Control control unit)

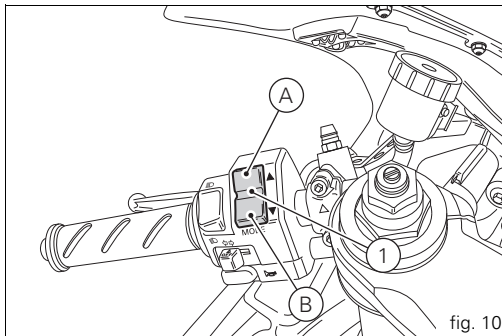

DTC SETUP (active only if DTC has been activated)
DQS OFF/ON (active on vehicle with Quick Shift)
TIME SET
CODE (only if active)



Important

This menu is active only if the speed of the motorcycle is less than 20 km/h. If this MENU is open and the speed of the motorcycle exceeds 20 km/h, the instrument panel automatically exits the menu and returns to the initial display. It is possible to exit the menu at any time, however, by pressing switch (12, fig. 6) in position A “▲” for 3 seconds.

E Total distance covered indicator: "Odometer"

This function shows the total distance covered by the vehicle.

This function shows the total distance covered by the vehicle.

Upon Key-On, the system automatically enters this function. The odometer reading is stored permanently and cannot be reset.

If the distance travelled exceeds 99999 km (or 99999 miles), the value "99999" will be displayed permanently.

EU, CND, FRA, JAP versions

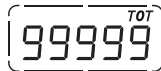

UK, USA versions

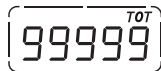
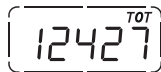

fig. 11

Air temperature indicator

This function shows the external temperature.

Display limits: $-39^{\circ}\text{C} \div +124^{\circ}\text{C}$

In the event of a sensor FAULT (-40°C , $+125^{\circ}\text{C}$ or disconnected), a string of dashes " - - - " (not flashing) is displayed and the "Engine diagnosis - EOBD" light comes on (8, fig. 3).

EU, CND, FRA, JAP versions

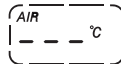
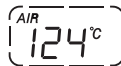
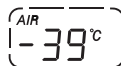

UK, USA versions

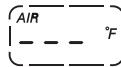
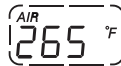
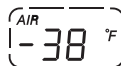

fig. 12

Vehicle speed indication

This function shows vehicle speed.

The instrument panel receives the actual speed value (expressed in km/h) from the ECU and displays the value increased by 8%.

Maximum speed displayed is 299 km/h (186 mph).

Over 299 km/h (186 mph) the display will show a series of dashes " - - - " (steadily lit - not flashing).

EU, CND, FRA, JAP versions

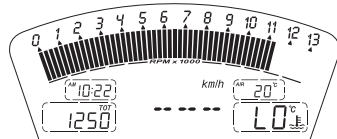

UK, USA versions

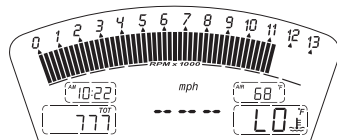
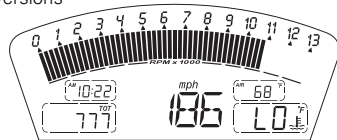

fig. 13

Engine coolant temperature indicator

It shows engine coolant temperature:

- If reading is $-40\text{ }^{\circ}\text{C}$ ($-40\text{ }^{\circ}\text{F}$) or less, the display shows a string of flashing dashes ("—") and the "Check Engine - EOBD" light (8, fig. 3) comes on;
- if reading is between $-39\text{ }^{\circ}\text{C}$ ($-38\text{ }^{\circ}\text{F}$) and $+39\text{ }^{\circ}\text{C}$ ($+102\text{ }^{\circ}\text{F}$), the word "LO" comes on steady on the display;
- if reading is between $+40\text{ }^{\circ}\text{C}$ ($+104\text{ }^{\circ}\text{F}$) and $+120\text{ }^{\circ}\text{C}$ ($+248\text{ }^{\circ}\text{F}$), the display shows temperature reading (on steady);
- if reading is between $+121\text{ }^{\circ}\text{C}$ ($+250\text{ }^{\circ}\text{F}$) and $+124\text{ }^{\circ}\text{C}$ ($+255\text{ }^{\circ}\text{F}$), the word "HI" is shown flashing on the display;
- if reading is $+125\text{ }^{\circ}\text{C}$ ($+257\text{ }^{\circ}\text{F}$) or higher, the display shows a string of flashing dashes ("—") and the "Engine diagnosis - EOBD" light (9, fig. 3) comes on.
- In the event of a sensor FAULT, a string of flashing dashes ("—") is shown and the "Engine diagnosis - EOBD" light (8, fig. 3) comes on.

EU, CND, FRA, JAP versions

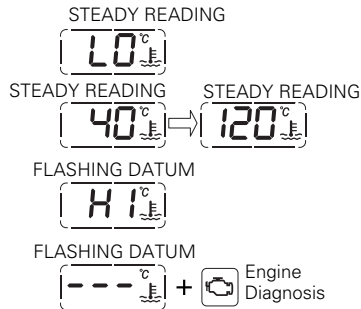

UK, USA versions

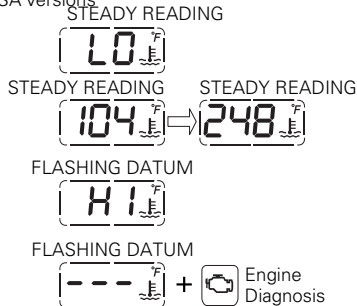

fig. 14

Trip meter "TRIP A"

This function shows the distance travelled since the Trip meter was last reset.

Holding button (12, fig. 6) pressed in position B "▼" for 3 seconds when this function is displayed resets the trip meter.

When the reading exceeds 999.9, distance travelled is reset and the meter automatically starts counting from 0 again.

EU, CND, FRA, JAP versions

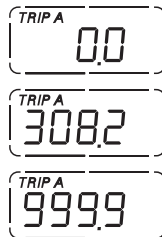

UK, USA versions

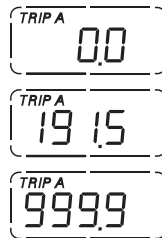

fig. 15

Trip meter "TRIP B"

This function shows the distance travelled since the Trip meter was last reset.

Holding button (12, fig. 6) pressed in position B "▼" for 3 seconds when this function is displayed resets the trip meter.

When the reading exceeds 999.9, distance travelled is reset and the meter automatically starts counting from 0 again.

EU, CND, FRA, JAP versions

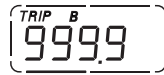
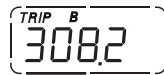
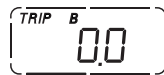

UK, USA versions

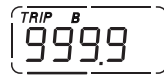
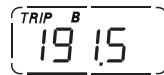
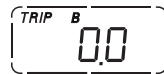

fig. 16

E Distance travelled on fuel reserve: "TRIP FUEL"

This function shows the distance travelled on fuel reserve. When the fuel warning light comes on, the TRIP FUEL meter is activated automatically, regardless of the function displayed. Trip fuel reading remains stored even after Key-Off until the vehicle is refuelled.

Count is interrupted automatically as soon as fuel is topped up to above minimum level.

When the reading exceeds 999.9, distance travelled is reset and the meter automatically starts counting from 0 again.

EU, CND, FRA, JAP versions

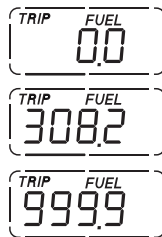

UK, USA versions

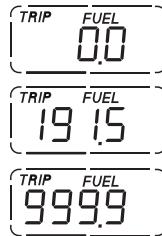

fig. 17

Service indicator (SERV)

It shows service intervals (service).

The message "SERV" is displayed at the following intervals:

after the first 1000 km on the odometer;

every 12000 km on the odometer.

The information is displayed only at Key-On for 5 seconds.

When the service indicator appears, contact your Ducati dealer or Authorised Service Centre.

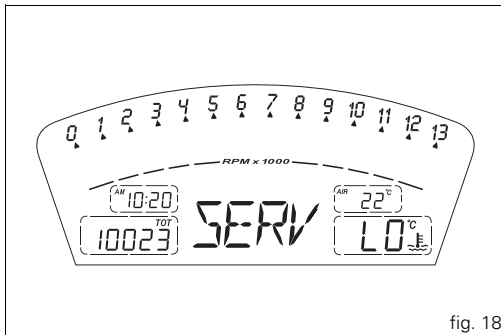

fig. 18

Battery voltage indicator (BATT)

This function provides battery voltage indication.

To display this function, go into the menu and select the "BATT" page.

The battery voltage reading is displayed as follows:

- if voltage is between 12.1 and 14.9 Volt, the reading is on steady;
- if voltage is between 10.0 and 12.0 Volt or between 15.0 and 16.0 Volt, the reading will be flashing;
- if voltage is 9.9 Volt or less, the word " LO " is shown flashing and the "Vehicle diagnosis" light (9, fig. 3) comes on;
- if voltage is 16.1 Volt or higher, the word " HI " is shown flashing and the "Vehicle diagnosis" light (9, fig. 3) comes on.

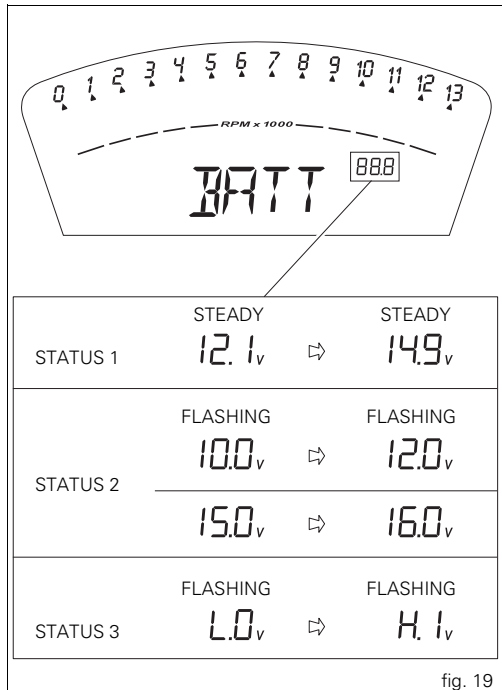

fig. 19

Engine idle RPM setting (RPM)

This function describes engine idle setup.

To display the function, go into the menu and call up the "RPM" page.

In addition to the upper rev counter scale, the display also shows engine rpm numerically so that you can adjust the idle speed more precisely.

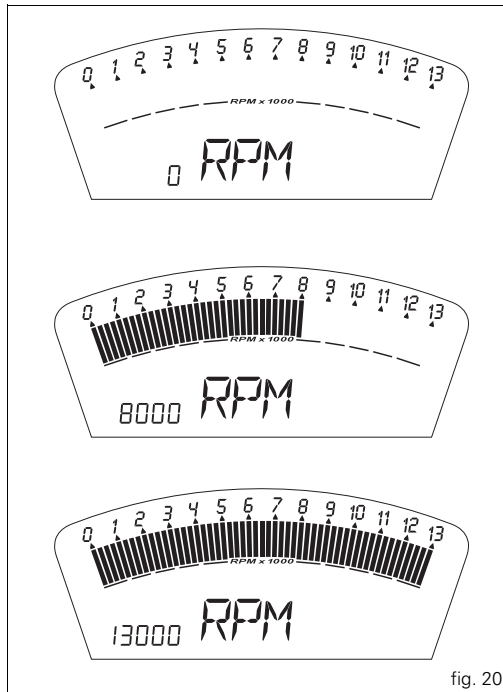

fig. 20

LAP timer

This function lets you display lap times.

To enable this function, enter the menu and set the "LAP" function to "On" by holding switch (12, fig. 6) pressed in position B "▼" for 3 seconds.

The lap timer is started and stopped using the high-beam flasher button FLASH (13, fig. 6) on the LH switch.

When the LAP function is active, each time you press the FLASH button, the display will show the lap time for 10 seconds, before reverting to normal mode.

Up to 30 lap times can be stored.

If the memory is full, each time you press the FLASH button, no more lap times can be saved and the display will show the flashing message "FULL" for 3 seconds until the memory is reset.

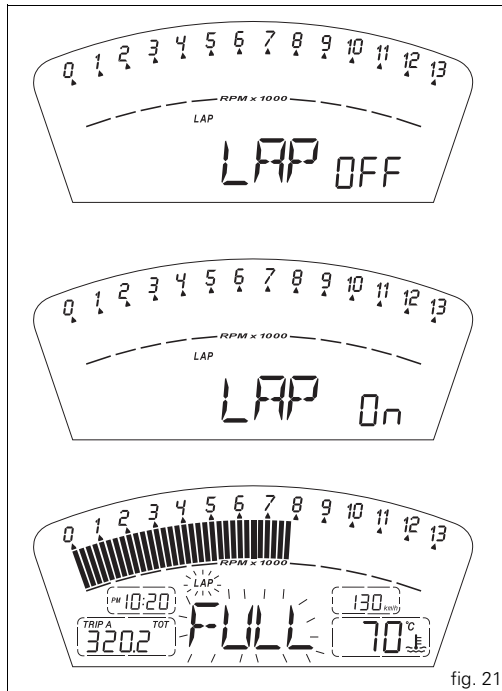

fig. 21

When the LAP function is set to Off in the menu, the current "lap" is not stored.

If the LAP function is active and the display is suddenly switched off (Key-Off), the LAP function is switched off automatically (even if the timer was ON, the lap in progress is not saved).

If the timer is not stopped, when it reaches 99 minutes, 59 seconds and 99 hundredths, it restarts from 0 (zero) and continues until the function is switched off.

If the LAP function is enabled without resetting the "memory" and there are less than 30 laps stored in the memory (for instance: 18 laps), the display will store any remaining laps until the memory is full (in this case, it will store an additional 12 laps).

This function only displays lap times; but other data are also saved (MAX speed, MAX rpm, rev limiter if reached) for viewing at a later date in the Lap Memory function.

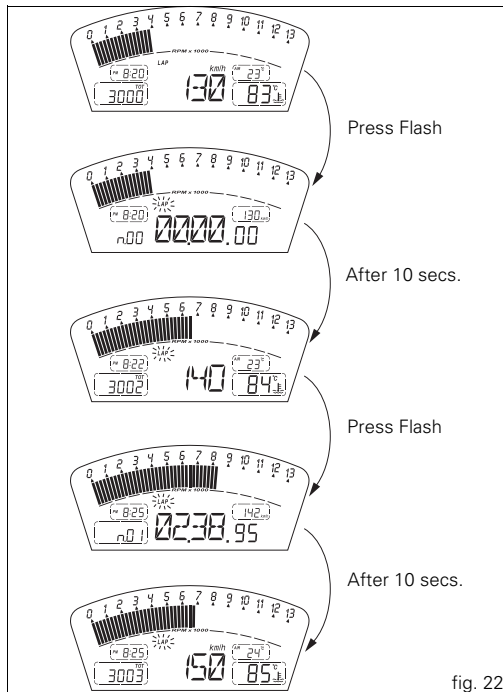

Stored data display (LAP Memory)

It displays data stored using the LAP function: lap time, MAX speed and MAX rpm.

To view stored lap times, enter the menu and go to page "LAP MEM".

Holding switch (12, fig. 6) pressed in position B "▼" for 3 seconds in this menu page accesses the "1st lap" view mode. The display will show the lap number, lap time, MAX speed and the MAX rpm reached for the lap in question.

Press switch (12, fig. 6) in position B "▼" repeatedly to scroll through the 30 laps stored until returning to the 1st lap.

If you press switch (12, fig. 6) in position B "▼" for 3 seconds while the saved times are displayed, the display immediately resets all the saved times and the LAP function is disabled automatically, if active.

The MAX speed saved is the maximum speed indicated on the display in Lap function.

If MAX speed reading exceeds 299 Km/h (186 mph) while the information is stored, speed reading is displayed (example: 316 Km/h).

If there is no reading in the memory, the 30 times are shown, with the display showing "00.00.00", MAX rpm = 0 and MAX speed = 0.

If the engine reached one of the two thresholds before the limiter or the limiter threshold during a lap, the corresponding lights (10, fig. 4) come on while viewing stored lap times.

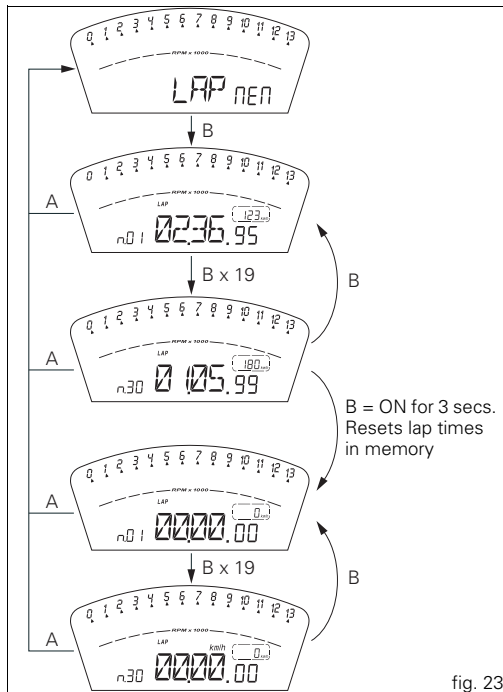

fig. 23

DDA data acquisition

This function activates the DDA analyzer (not fitted for this model, but available at Ducati selling network): the data logger must be connected to vehicle wiring.

To enable this function, enter the menu and set "DDA" data logger to "On" by holding switch (12, fig. 6) pressed in position B "▼" for 3 seconds.

The START/STOP control for the data logger lap separator is the high-beam flash button FLASH (12, fig. 6) on the LH switch.

If the DDA function is active and the display is suddenly switched off (Key-Off), the function is switched off automatically.



Note

Online assistance is available to Ducati Data Analyzer (DDA) owners (<http://dda.prosa.com>). This service will provide anything necessary to correctly use the DDA with your PC: both for the device and the software for analysing the recorded data.



Warning

After use, disconnect the DDA from the main wiring harness.

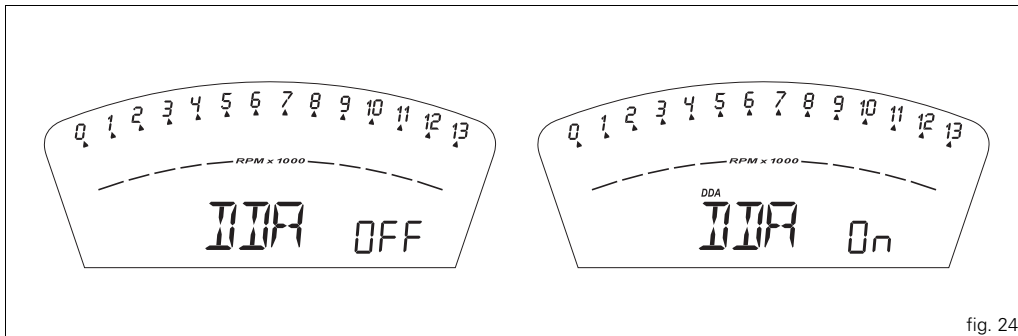

fig. 24

E Erase DDA

This function deletes data stored in the DDA (not fitted for this model, but available from the Ducati network): the data logger must be connected to vehicle wiring.

To erase data, enter the menu page "Erase DDA".

If you press switch (12, fig. 6) in position B "▼" for 3 seconds and the DDA is not acquiring data, the message "WAIT..." is shown on the display for 10 seconds; after these 10 seconds, message "ERASE OK" is displayed for 2 seconds to confirm that the data in the DDA data logger have been erased.

If switch (12, fig. 6) is pressed in the B "▼" position for 3 seconds while the DDA data logger is acquiring data, the data logger memory is not erased and the display shows message "FAIL" for 2 seconds.

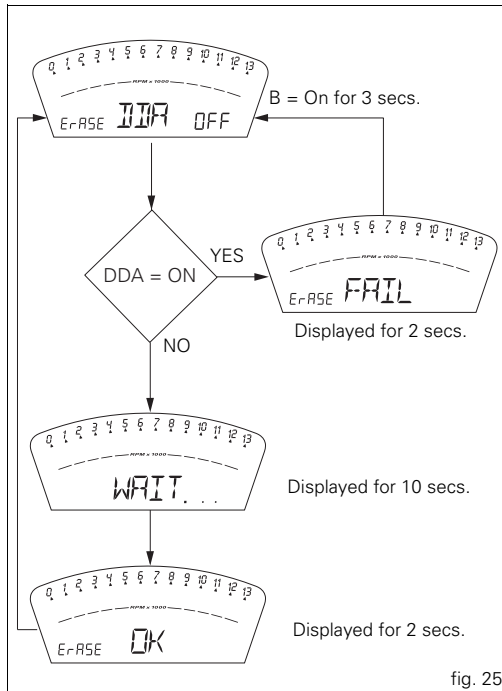

Function for activation / deactivation of DTC (Ducati Traction Control)

It is used to activate the Ducati Traction Control system: DTC.

Description of the system



Warning

DTC is a rider aid that can be used both on the track and the road.

The system is designed to make riding easier and to enhance safety, but in no way relieves the rider of the obligation to drive responsibly and to maintain a high standard of riding in

order to avoid accidents, whether caused by his own errors or those of other road users, through making emergency manoeuvres, in accordance with the prescriptions of the road traffic code.

The rider must always be aware that active safety systems have a preventive function. The active elements help the rider control the motorcycle, making it as easy and safe to ride as possible. The presence of an active safety system should not encourage the rider to ride at speeds beyond the reasonable limits, in accordance with the road conditions, the laws of physics, good riding standards and the requirements of the road traffic code.

E

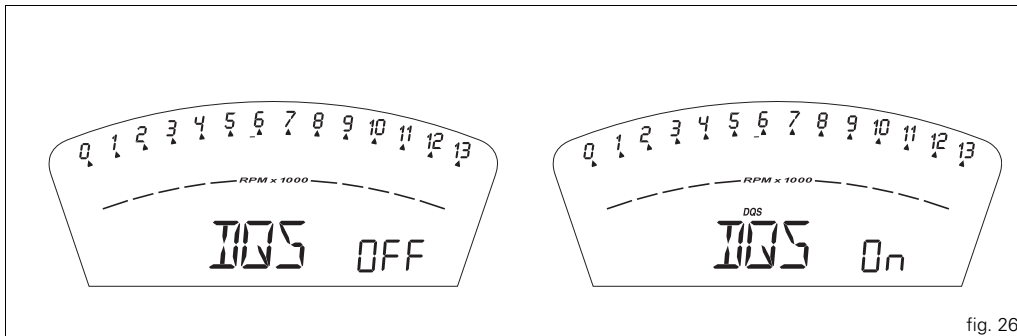

fig. 26

Activation of the system

To activate the system, the motorcycle must be stationary and safely parked.

To enable Traction Control, enter the menu and set "DTC" to "On" by pressing switch (12, fig. 6) in position B "▼" for 3 seconds; once the 3 seconds have elapsed, the message "DTC" will appear on the display to indicate activation of the Ducati Traction Control system. When activated, the message "DTC" is visible both on the normal display and also within the menu pages.

The functions of the system



Note

To operate the system, the motorcycle must be stationary and safely parked.

Each time DTC is activated, the Traction Control ECU will set the sensitivity level to 8; the level may then be adjusted using the function "Traction Control Sensitivity Level Setting (DTC SETUP)".

To disable Traction Control, enter the menu and set "DTC" to "OFF" by pressing switch (12, fig. 6) again in position B "▼" for 3 seconds; once the 3 seconds have elapsed, the message "DTC" will disappear from the display, thereby indicating deactivation of the Ducati Traction Control system. If the engine suddenly stops or is switched off (Key-Off) while Traction Control is activated, the function will NOT be disabled but will still be active (DTC On) at the next Key-ON.

If, however, battery power is suddenly cut off (Batt-OFF), when battery power is restored and upon next Key-On, the Traction Control will no longer be activated (DTC OFF).

Routine maintenance

To ensure that system continues to function correctly it is necessary to observe the manufacturer's programmed maintenance schedule.

DTC (Ducati Traction Control) setting function

This function serves to set the sensitivity level for the DTC (Ducati Traction Control).

To set the Traction Control sensitivity level, with the motorcycle stationary, enter the "Setup DTC" menu page. This page only appears in the menu once the Traction Control ECU has been activated (DTC ON).

The Traction Control sensitivity level setting (L.1.....L.8) is indicated on the right-hand side of the display. The sensitivity levels range from "1" to "8"; the higher the number, the greater the intervention of the Traction Control system (see following paragraph).

Within this menu page, press switch (12, fig. 6) in position B "▼" for 3 seconds to access the level setting function.

page 1: the display will show "Setup LEV. 1".

If you wish to set this level, press switch (12, fig. 6) in position B "▼" for 3 seconds; the instrument panel will automatically quit this page and return to the initial display, with the level setting indicated on the right.

If instead you wish to set the next highest level, press switch (12, fig. 6) in position B "▼".

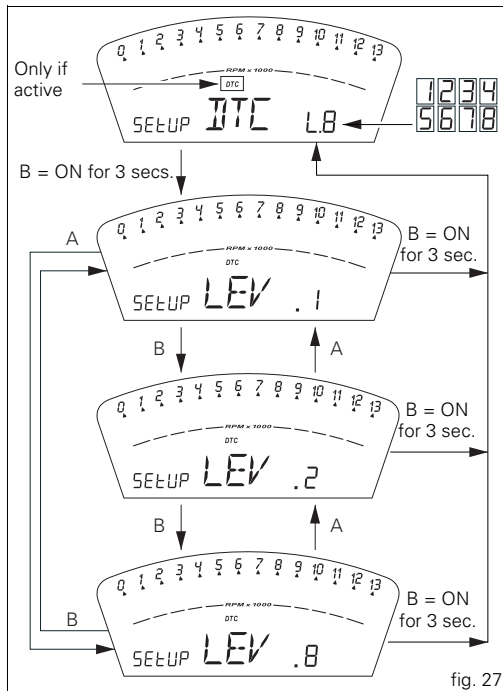

fig. 27

E page 2: the display will show "Setup LEV. 2".

If you wish to set this level, press switch (12, fig. 6) in position B "▼" for 3 seconds; the instrument panel will automatically quit this page and return to the initial display, with the level setting indicated on the right.

If instead you wish to set the next highest level, press switch (12, fig. 6) in position B "▼". While if you wish to go back to the previous level, press switch (12, fig. 6), in position A "▲".

page 3: the display will show "Setup LEV. 3".

If you wish to set this level, press switch (12, fig. 6) in position B "▼" for 3 seconds; the instrument panel will automatically quit this page and return to the initial display, with the level setting indicated on the right.

If instead you wish to set the next highest level, press switch (12, fig. 6) in position B "▼". While if you wish to go back to the previous level, press switch (12, fig. 6), in position A "▲".

page 4: the display will show "Setup LEV. 4".

If you wish to set this level, press switch (12, fig. 6) in position B "▼" for 3 seconds; the instrument panel will automatically quit this page and return to the initial display, with the level setting indicated on the right.

If instead you wish to set the next highest level, press switch (12, fig. 6) in position B "▼". While if you wish to go back to the previous level, press switch (12, fig. 6), in position A "▲".

page 5: the display will show "Setup LEV. 5".

If you wish to set this level, press switch (12, fig. 6) in position B "▼" for 3 seconds; the instrument panel will automatically quit this page and return to the initial display, with the level setting indicated on the right.

If instead you wish to set the next highest level, press switch (12, fig. 6) in position B "▼". While if you wish to go back to the previous level, press switch (12, fig. 6), in position A "▲".

page 6: the display will show "Setup LEV. 6".

If you wish to set this level, press switch (12, fig. 6) in position B "▼" for 3 seconds; the instrument panel will automatically quit this page and return to the initial display, with the level setting indicated on the right.

If instead you wish to set the next highest level, press switch (12, fig. 6) in position B "▼". While if you wish to go back to the previous level, press switch (12, fig. 6), in position A "▲".

page 7: the display will show "Setup LEV. 7".

If you wish to set this level, press switch (12, fig. 6) in position B "▼" for 3 seconds; the instrument panel will automatically quit this page and return to the initial display, with the level setting indicated on the right.

If instead you wish to set the next highest level, press switch (12, fig. 6) in position B "▼". While if you wish to go back to the previous level, press switch (12, fig. 6), in position A "▲".

page 8: the display will show "Setup LEV. 8".

If you wish to set this level, press switch (12, fig. 6) in position B "▼" for 3 seconds; the instrument panel will automatically quit this page and return to the initial display, with the level setting indicated on the right.

If instead you wish to set the next highest level, press switch (12, fig. 6) in position B "▼". While if you wish to go back to the previous level, press switch (12, fig. 6), in position A "▲".

If DTC is activated, the level setting can also be displayed when quitting the page "SETUP DTC" at the end of the TOT, TRIP A, TRIP B and TRIP Fuel display functions.

The level setting will remain in memory even after Key-Off.

If, however, battery power is suddenly cut off (Batt-OFF), when battery power is restored and upon next Key-On, the Traction Control will no longer be activated (DTC OFF).

Tips on how to select the sensitivity level



Warning

The 8 DTC level settings have been calibrated using the same tyres as those originally supplied with your motorcycle (same make, model and size).

The use of tyres of different size to the original tyres may alter the operating characteristics of the system.

In the case of minor differences, such as for example, tyres of a different make and/or model than the OE ones, but with the same size (rear = 180/55-17; front = 120/70-17), it may be sufficient to simply select the suitable level setting from those available to restore optimal system operation.

If tyres of a different size class are used or if the tyre dimensions differ significantly from the original tyres, it may be that the system operation is affected to the point where none of the 8 available level settings will give satisfactory results.

In this case it is advisable to deactivate the traction control system.

If level 8 is selected, the DTC control unit will kick in at the slightest hint that the rear wheel is starting to spin.

Between level 8 and level 1 there are a further 6 intermediate levels. The level of DTC sensitivity decreases in equal steps from level 8 to level 1.

When level 1, 2 or 3 is selected the DTC control unit will allow the rear wheel to spin and also slide sideways on exiting a corner; we recommend that this setting is only used by very experienced riders on the track.

E The choice of the correct level depends on 3 main variables:

- 1) The grip (type of tyre, amount of tyre wear, the road/ track surface, weather conditions, etc.)
- 2) The characteristics of the path/circuit (bends all taken at similar speeds or at very different speeds)
- 3) The riding mode (whether the rider has a "smooth" or a "rough" style)

Relation of the DTC sensitivity level to grip conditions:

The choice of level setting depends greatly on the grip conditions of the track/circuit (see below, tips for use on the track and on the road).

Relation of the DTC sensitivity level to the path characteristics:

If all the corners on the track/circuit can be taken at a similar speed, it will be easier to find an intervention level that is satisfactory for every bend; on the other hand, if the track has, for example, one corner that is much slower than all the others, it will be necessary to find a compromise level (on the slow corner the DTC will tend to kick in more than on the faster corners).

The relation of the DTC intervention level to riding mode :

The DTC will tend to kick in more with a "smooth" riding mode, where the bike is leaned over further, rather than with a "rough" style, where the bike is straightened up as quickly as possible when exiting a turn.

Tips for use on the track

We recommend that level 8 is used for a couple of full laps (to allow the tyres to warm up) in order to get used to the system. Then try levels 7, 6, etc., in succession until you identify the DTC sensitivity level that suits you best (always try each level for at least two laps to allow the tyres to warm up).

Once you have found a satisfactory setting for all the corners except one or two slow ones, where the system tends to kick in and control too much, you can try to modify your riding mode slightly to a more "rough" approach to cornering i.e. straighten up more rapidly on exiting the corner, instead of immediately trying a different level setting.

Tips for use on the road

Activate the DTC, select level 8 and ride the motorcycle in your usual style; if the level of DTC sensitivity seems excessive, try reducing the setting to level 7, 6, etc., until you find the level that suits you best.

If changes occur in the grip conditions and/or circuit characteristics and/or your riding style, and the level setting is no longer suitable, switch to the next level up or down and proceed to determine the best setting (e.g. if with level 7 the DTC intervention seems excessive, switch to level 6; alternatively, if on level 7 you cannot perceive any DTC intervention, switch to level 8).

Quick Shift (DQS ON/OFF) enable / disable function

This function allows disabling, and if necessary also re-enabling, DQS - Ducati Quick shift.



Note

This page is displayed in the menu only if upon "Start-UP" the engine control unit informs the Instrument Panel that the "Quick Shift" function is present. The function is "usually" enabled (DQS On).

To disable the "DQS" function, enter the menu and set the function to "OFF" by holding switch (12, fig. 6) pressed in position B "▼" for 3 seconds.

The function can be re-enabled:

- 1) either by switching the bike off (Key-Off); upon the next Key-On the "DQS" function will be active again (On);
- 2) or by entering again the menu page "DQS", and setting the function to "On" by holding switch (12, fig. 6) pressed in position B "▼" for 3 seconds.

If battery power is cut off (Batt-Off), when battery power is restored and upon the next Key-On, the function will be automatically disabled (DQS On).

E

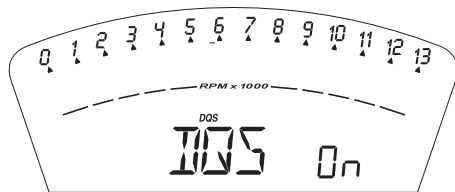
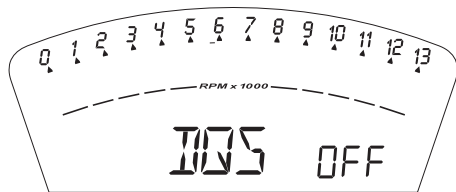

fig. 28

Clock setting function

This function is used to set the clock time.

To set the clock, select the "TIME Set" page from the menu. Holding switch (12, fig. 6) pressed in position B "▼" for 3 seconds in this menu page gives access to the setup mode. When you access this function, the text "AM" flashes; if you press switch (12, fig. 6) in position B "▼" the text "PM" flashes; if you press switch (12, fig. 6) in position B "▼" mode will go back to previous setting (if it is 00:00, when toggling from "AM" to "PM", 12:00 will be displayed). Pressing switch (12, fig. 6) in position A "▲" gives access to the hour setting mode; hours start to flash. Each time you press the button in position B "▼", the digit will increase by one hour. If the switch is held pressed in position B "▼" the number increases cyclically in steps of one hour every second (when the switch is held depressed, the hours do not flash).

Pressing switch (12, fig. 6) in position A "▲" gives access to the minute setting mode; minutes start to flash. Each time you press the button in position B "▼", the digit will increase by 1 minute. If you hold the switch down in position B "▼", the count increases cyclically in steps of 1 minute every second. If the button is held depressed in position B "▼" for over 5 seconds, minutes will increase by 1 minute every 100ms (while the button is held depressed in position B "▼", seconds will not flash).

Pressing the button in position A "▲", exits setup mode and the new time is displayed.

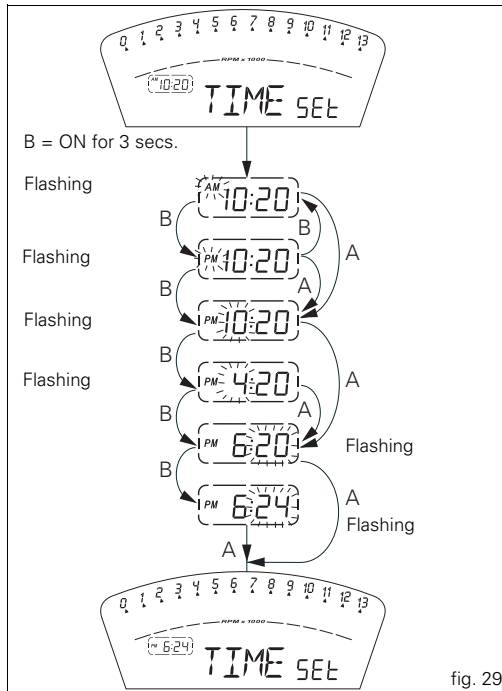

fig. 29

Instrument panel diagnostics

Important

The instrument panel runs system diagnostics after 60 seconds from the last Key-Off.

Any abnormal vehicle behaviour is displayed. If more errors are present, they are displayed one by one every 3 seconds.







Possible errors are listed in the table below.

























Warning











When an error is displayed, always contact a Ducati Dealer or authorised Service Center.











E

WARNING LIGHT	ERROR MESSAGE		ERROR
	COIL	8.1	Horizontal cylinder coil error
	COIL	8.2	Horizontal cylinder coil error
	COIL	9.1	Vertical cylinder coil error
	COIL	9.2	Vertical cylinder coil error
	COIL	10.1	Horizontal cylinder coil error
	COIL	10.2	Horizontal cylinder coil error
	COIL	11.1	Vertical cylinder coil error

WARNING LIGHT	ERROR MESSAGE		ERROR
	COIL	11.2	Vertical cylinder coil error
	INJE	12.1	Horizontal cylinder injector error
	INJE	12.2	Horizontal cylinder injector error
	INJE	13.1	Vertical cylinder injector error
	INJE	13.2	Vertical cylinder injector error
	INJE	14.1	Horizontal cylinder injector error
	INJE	14.2	Horizontal cylinder injector error
	INJE	15.1	Vertical cylinder injector error
	INJE	15.2	Vertical cylinder injector error
	PUMP	16.0	Fuel pump relay error
	FAN	18.1	Fan relay error

WARNING LIGHT	ERROR MESSAGE		ERROR
	FAN	18.2	Fan relay error
	STRT	19.1	Solenoid starter error
	STRT	19.2	Solenoid starter error
	STEP.	21.1	Stepper motor error
	STEP.	21.2	Stepper motor error
	STEP.	21.3	Stepper motor error
	LAMB.	22.1	Lambda heaters error
	LAMB.	22.2	Lambda heaters error
	EXVL	23.1	Exhaust butterfly valve motor error
	EXVL	23.2	Exhaust butterfly valve motor error
	EXVL	23.3	Exhaust butterfly valve motor error

WARNING LIGHT	ERROR MESSAGE		ERROR
	EXVL	23.4	Exhaust butterfly valve motor error
	TPS	1.1	Throttle position sensor error
	TPS	1.2	Throttle position sensor error
	PRESS	2.1	Pressure sensor error
	PRESS	2.2	Pressure sensor error
	T.WAT	3.1	Engine water temperature sensor error
	T.WAT	3.2	Engine water temperature sensor error
	AIR	4.1	Air temperature sensor error
	AIR	4.2	Air temperature sensor error
	BATT	5.1	Battery voltage error
	BATT	5.2	Battery voltage error

WARNING LIGHT	ERROR MESSAGE		ERROR
	LAMB	6.1	Lambda sensor error
	TILT	6.2	Lambda sensor error 2
	DTC	8.0	Traction control ECU error
	ECU	30.0	Engine Control Unit error
	PK.UP	34.0	Pick-up sensor error
	SPEE.	36.0	Speed sensor error
	IMMO	37.0	Immobilizer error
	IMMO	37.1	Immobilizer error
	IMMO	37.3	Immobilizer error
	IMMO	37.5	Immobilizer error
	CAN	38.0	CAN communication line error

Instrument panel backlighting

The instrument panel backlighting is always activated by Key-On.

The instrument panel is equipped with sensors that detect the ambient light level and at night reduce the maximum backlighting level by 20% to prevent glare.

Headlight “smart” auto-off

This function helps reduce battery use by automatically switching off the headlight. The device is enabled in three instances:

- 1) When the key is turned from OFF to ON and the engine is not started within 60 seconds, the headlight is turned off and will be turned back on next time you start the engine.
- in case 2, after the vehicle has been running with the headlights on and the engine is stopped using the RUN-STOP button on the RH switch.
In this case, 60 seconds after stopping the engine, the headlight is turned off and will be turned back on next time you start the engine.
- 3) While starting up the engine, the headlight is turned off and back on as soon as the engine is started.

Headlight “smart” SWITCH-ON

This function allows programmed activation of the headlight even with the motorcycle off (Key-Off).

The instrument panel stays active for 60 seconds soon after Key-Off, and the headlight can be switched on by pressing switch (12, fig. 6) in position B “▼”.

During these 60 seconds, each time switch (12, fig. 6) is pressed in position B “▼”, the instrument panel will activate the headlight for 30 seconds; each press will add to the headlight activation time, up to a maximum of 6 presses of switch (12, fig. 6) in position B “▼” (equivalent to a maximum activation time of 180 seconds).

After the first time you press switch (12, fig. 6) in position B “▼”, the period of 30 seconds starts, thus switching on the headlight. Further switch-on time can be added only if you press the switch again within these 30 seconds. If the 30 seconds have elapsed, no further multiples of 30 seconds can be added, and the instrument panel will switch off the headlight.

To reset this function, you must perform at least one Key-On/Key-Off.

If the battery power is interrupted at any time while this function is active, when power is restored, the instrument panel will deactivate the function (the instrument panel does not remain active for 60 seconds).

The Immobilizer system

For improved antitheft protection, the motorcycle is equipped with an IMMOBILIZER, an electronic system that inhibits engine operation whenever the ignition switch is turned off.

Accommodated in the handgrip of each ignition key is an electronic device that modulates an output signal. This signal is generated by a special antenna incorporated in the switch when the ignition is turned on and changes every time. The modulated signal represents the "password" (which is changed at each start-up) by which the ECU recognizes the ignition key. The ECU will only allow the engine to start if it recognises this password.

Keys (fig. 30)

The Owner receives a set of keys comprising:

- 2 (BLACK) keys B

These keys contain the "immobilizer system code".



Note

Your Ducati dealer may ask you to produce your Code Card in order to carry out certain servicing operations.

The black keys (B) are regular ignition keys and are used to:

- start up the engine.
- open the fuel tank filler plug.
- open the seat lock.



Note

The two keys have a small plate (1) attached that reports their identification number.



Warning

Keep the keys separate, and store the tag (1) in a safe place.

It is also advisable to use only one of the black keys to start the motorcycle.

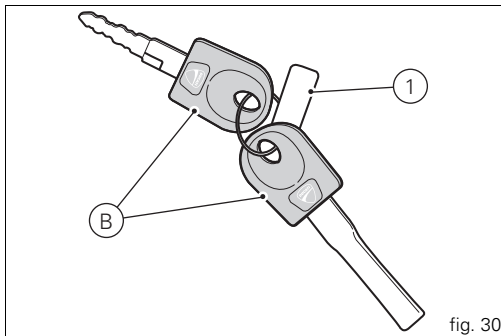

fig. 30

Code Card

The CODE CARD (fig. 31) supplied with the keys reports an electronic code (A, fig. 32) to start the engine in the event it fails to start after KEY-ON because the immobilizer system inhibited the ignition.



Warning

Keep the CODE CARD in a safe place. However, it is advisable to keep the electronic code printed on the CODE CARD handy when you ride your motorcycle, in case it is necessary to enable the engine through the procedure described below. This procedure lets you disable the "engine block" function - indicated by the amber Vehicle diagnosis light (9, fig. 3) coming on - in the event of problems with the immobilizer system.

This operation is only possible if the electronic code indicated on the code card is known.



Warning

Your dealer will ask you to produce the Code Card in order to reprogram or replace a key.

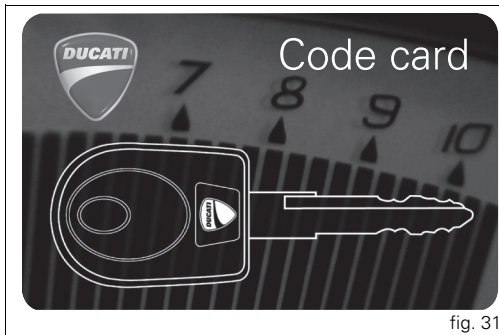

fig. 31

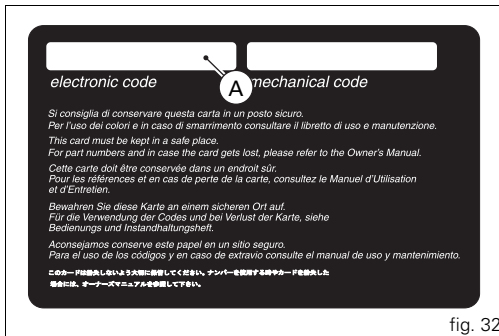

fig. 32

Immobilizer override procedure

Should the immobilizer become locked, you can perform the "Immobilizer Override" procedure from the instrument panel by entering the respective function as described below. Enter the menu and go to page "CODE".



Note

This menu should only be active when at least one Immobilizer error is present.

This page menu shows a default "00000" code. If you hold switch (12, fig. 6) depressed in position B "▼" for 3 seconds, you will access the procedure for entering the electronic code given on the Code Card.

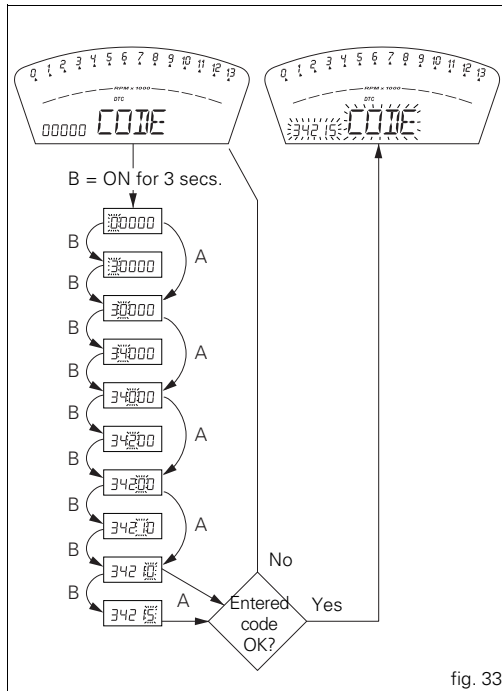

fig. 33

Entering the code:

when you access this function, the first digit on the left will flash.

Button (1, fig. 8):

each time you press the switch in position B "▼", the number increases cyclically in steps of one digit every second;

if you press the button in position A "▲", you will move to the second digit, which will start to flash. Each time you press the switch in position B "▼", the number increases cyclically in steps of one digit every second;

if you press the switch in position A "▲", you can set the third digit, which will start flashing. Each time you press the switch in position B "▼", the number increases cyclically in steps of one digit every second;

if you press the button in position A "▲", you will move to the fourth digit, which will start to flash. Each time you press the switch in position B "▼", the number increases cyclically in steps of one digit every second;

if you press the switch in position A "▲", you can set the fifth digit, which will start flashing. Each time you press the switch in position B "▼", the number increases cyclically in steps of one digit every second;

press in position A "▲" to confirm the code.

If the code has been entered correctly, the word "CODE" and the code you just entered will flash for 4 seconds.

The "Vehicle diagnosis" light (9, fig. 3) will turn off; the instrument panel automatically exits the menu and the engine start-up inhibition is temporarily overridden.

If the error is still present, at the next Key-On the instrument panel error and the inhibited status will persist.

If the code is not entered correctly, the instrument panel reverts to the "CODE" menu and display the default "00000" code.

Operation

When the ignition key is turned to OFF, the immobilizer inhibits engine operation. When the ignition key is turned back to ON to start the engine, the following happens:

- 1) if the code is recognised, the immobilizer enables engine ignition. Press the START button (2, fig. 39), to start the engine;
- 2) if the "Vehicle diagnosis" light (9, fig. 3) comes on and the page with the message "Error IMMO" is displayed when you press switch (12, fig. 6) in position B "▼", it means that the code was not recognised. When this is the case, turn the ignition key back to OFF and then to ON again. If the engine still does not start, try with another black key. If the other key does not work out either, contact the Ducati Service network.



Warning

Any important shock might damage the electronic components fitted into the key.

Use only one key during the procedure. Failure to do so might prevent the system from recognising the code of the key in use.

Duplicate keys

If you need additional keys, contact your DUCATI Service Centre with all the keys you have in your possession and your CODE CARD.

The Ducati Service Centre will program all the new keys as well as any keys you already have.

You may be asked to provide proof that you are the legitimate owner of the motorcycle.

The codes of any keys not submitted will be wiped off from the memory to make those keys unserviceable in case they have been lost.



Note

If you sell your motorcycle, do not forget to give all keys and the CODE CARD to the new owner.

E Service menu - unit of measurement (UNIT SET)

This function allows you to select the units of measurement displayed on the instrument panel.

To enter the menu service push button (1, fig. 10) in position A "▲" while turning the key from "Off" to "On".



Note

Within this MENU all other functions are excluded and motorcycle starting is disabled.

The first function displayed is the "Immobilizer Reprogramming" procedure (REPR Code), pressing the button (1, fig. 10) in the position A "▲" or B "▼" select the "Setting Special" (Set UNIT) function.

Now press the button (1, fig. 10) in the position B "▼" for 3 seconds.

Each time you press switch (1, fig. 10) "▼" in the position B "▼", the instrument panel scrolls through the following sequence of options, which flash on the display:

UNIT OF MEASUREMENT			
Country standard	Speed	Air temperature	Odometer/ trip meters
EU	Km/h	°C	Km
EN	mph	°C	miles
USA	mph	°F	miles
CND	Km/h	°C	Km
FRA	Km/h	°C	Km
JAP	Km/h	°C	Km
ECU Id.	The instrument panel sets units of measurement according to ECU information		

If you press the button (1, fig. 10) in position B "▼" for 3 seconds, the option currently displayed will be saved to memory and the word "MEM" will appear. Upon the following Key-On the instrument panel will be set to the new settings.

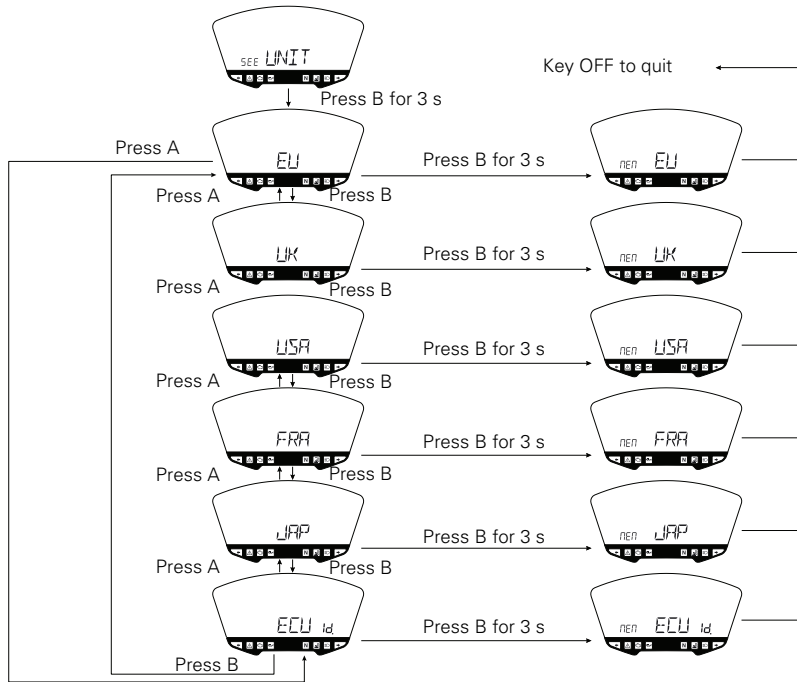

fig. 34

E Controls



Warning

This section shows the position and function of the controls used to ride the motorcycle. Be sure to read this information carefully before you use the controls.

Position of motorcycle controls (fig. 35)

- 1) Instrument panel.
- 2) Key-operated ignition switch and steering lock.
- 3) Left-hand handlebar switch.
- 4) Clutch lever.
- 5) Rear brake pedal.
- 6) Right-hand handlebar switch.
- 7) Throttle twistgrip.
- 8) Front brake lever.
- 9) Gear change pedal.

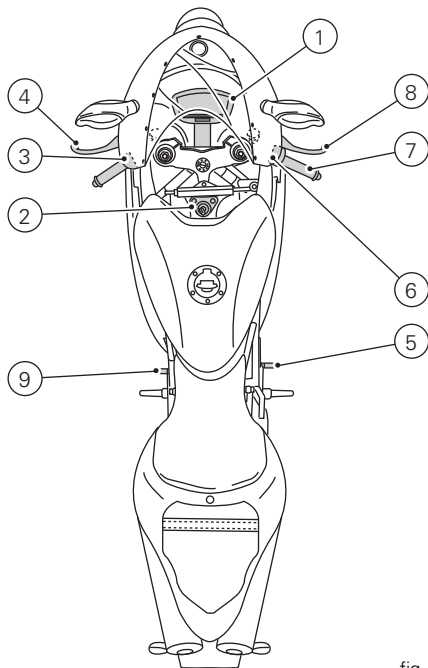

fig. 35

Key-operated ignition switch and steering lock (fig. 36)

It is located in front of the fuel tank and has four positions:

- A) ON: enables lights and engine operation;
- B) OFF: disables lights and engine operation;
- C) LOCK: the steering is locked;
- D) P: parking light on and steering locked.



Note

To move the key to the last two positions, press it down before turning it. The key can be removed in positions (B), (C) and (D).

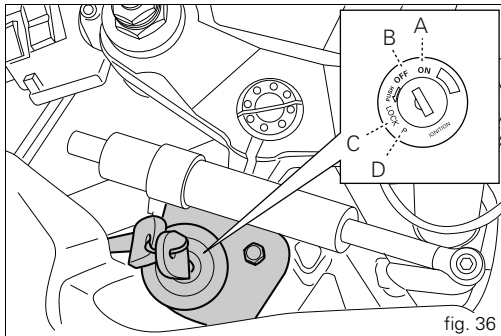

E

LH switch (fig. 37)

1) Dip switch, two-position light selector switch:

position  = low beam on;

position  = high beam on.

2) Switch  = 3-position turn indicator:

centre position = off;

position  = left turn;

position  = right turn.

To cancel turn indicators, push in once switch returns to central position.

3) Button  = warning horn.

4) Button  = high-beam flasher (FLASH) and instrument panel control.

5) Two-position instrument panel control switch:

position "▲";

position "▼".

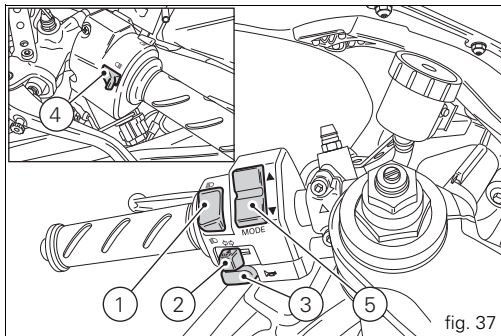

Clutch lever

Lever (1) disengages the clutch. It features a dial adjuster (2) for lever distance from the twistgrip on handlebar.

The lever distance can be adjusted through 10 clicks of the dial (2). Turn clockwise to increase lever distance from the twistgrip. Turn the adjuster counter clockwise to decrease lever distance.

When the clutch lever (1) is operated, drive from the engine to the gearbox and the drive wheel is disengaged. Using the clutch properly is essential to smooth riding, especially when moving off.



Warning

Set clutch lever when motorcycle is stopped.



Important

Using the clutch properly will avoid damage to transmission parts and spare the engine.



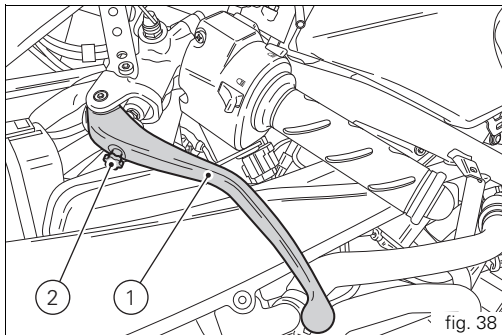

Note

It is possible to start the engine with the side stand down and the gearbox in neutral. When starting the bike with a gear engaged, pull the clutch lever (in this case the side stand must be up).



RH switch (fig. 39)

1) ENGINE STOP switch, two positions:
position  (RUN) = run;
position  (OFF) = stop.



Warning

This switch is mainly intended for use in emergency cases when you need to stop the engine quickly. After stopping the engine, return the switch to the  position to enable starting.



Important

Stopping the engine using switch (1) after riding with the lights on and leaving the ignition key in the **ON** position, may run the battery flat as the lights will remain on.

2) Button  = engine start.

Throttle twistgrip (fig. 39)

The twistgrip (3) on the right-hand handlebar opens the throttles. When released, it will spring back to the initial position (idling speed).

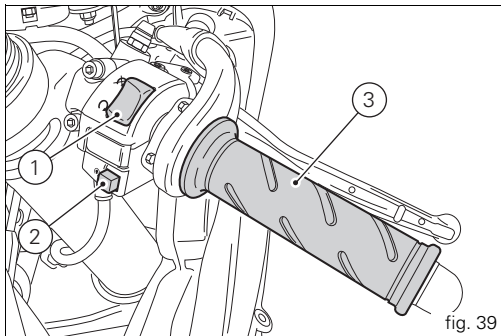

fig. 39

Front brake lever (fig. 40)

Pull in the lever (1) towards the twistgrip to operate the front brake. The system is hydraulically operated and you just need to pull the lever gently.

The brake lever (1) has a dial (2) for adjusting the distance between lever and twistgrip on the handlebar.

The lever distance can be adjusted through 10 clicks of the dial (2). Turn clockwise to increase lever distance from the twistgrip. Turn the adjuster counter clockwise to decrease lever distance.

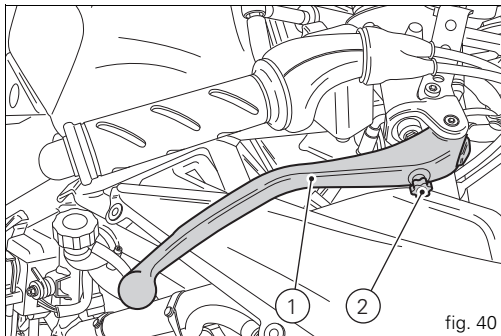

Rear brake pedal (fig. 41)

Push down on the pedal (1) to apply the rear brake. The system is hydraulically operated.

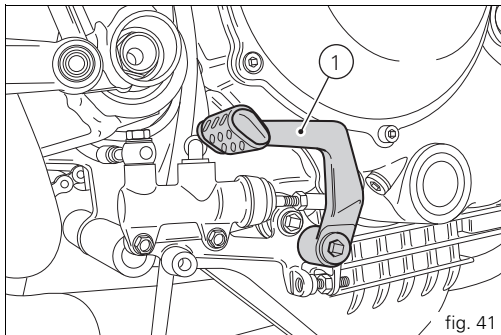

fig. 41

Gear change pedal (fig. 42)

When released, the gear change pedal automatically returns to rest position N in the centre. This is indicated by the instrument panel light N (3, fig. 3) coming on.

The pedal can be moved:

down = press down the pedal to engage the 1st gear and to shift down. The N light will go out;

upwards = lift the pedal to engage 2nd gear and then 3rd, 4th, 5th and 6th gears.

Each time you move the pedal you will engage the next gear.

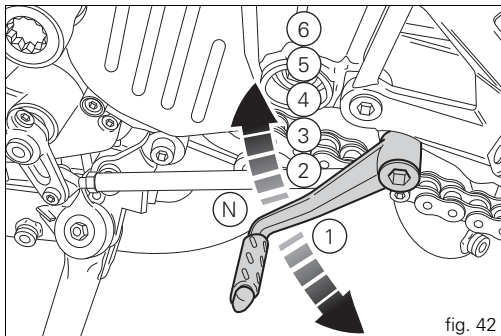

fig. 42

Setting the gear change and rear brake pedals (fig. 43 and fig. 44)

The gear change and rear brake pedals can be adjusted to suit the preferred riding position of each rider.

To adjust the position, proceed as follows:
hold the rod (1) and loosen lock nuts (2) and (3).



Note

Nut (2) has a left-hand thread.

Fit an open-end wrench to hexagonal element of linkage (1) and rotate until setting pedal in the desired position.
Tighten both check nuts onto linkage.

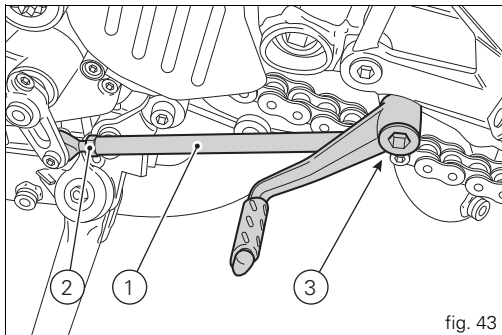

To set the rear brake pedal, proceed as follows.

loosen counter nut (4).

Turn pedal travel adjusting screw (5) until pedal is in the desired position.

Tighten the check nut (4) to 2.3 Nm.

Work pedal by hand to make sure it has 1.5 - 2 mm free play before brake begins to bite.

If not so, set the length of cylinder linkage as follows.

Loosen the check nut (6) on cylinder linkage.

Tighten linkage into fork (7) to increase play, or unscrew linkage to reduce it.

Tighten the check nut (6) to 7.5 Nm and check play again.

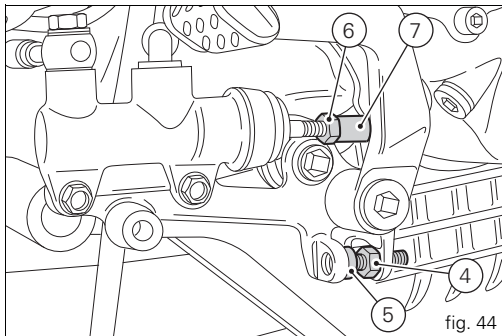

Main components and devices

E

Position on the vehicle (fig. 45)

- 1) Tank filler plug.
- 2) Seat lock.
- 3) Side stand.
- 4) Steering damper.
- 5) Rear-view mirrors.
- 6) Front fork adjusters.
- 7) Rear shock absorber adjusters.
- 8) Exhaust silencer (see "Warning" on page 78).
- 9) Catalytic converter.

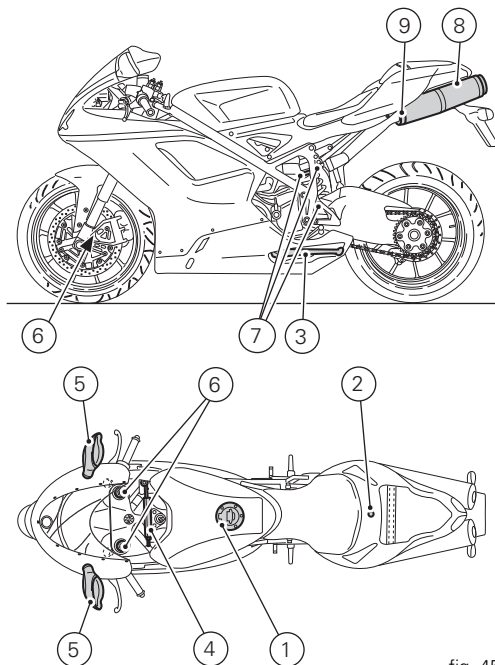

fig. 45

E Fuel tank plug (fig. 46)

Opening

Lift the protection lid (1) and fit the ignition key into the lock. Turn the key clockwise 1/4 turn to unlock. Lift the plug.

Closing

Refit the plug with the key in it and push it down into its seat. Turn the key counter-clockwise to the initial position and remove it. Close the lock protection lid (1).



Note

The plug can only be closed with the key in.



Warning

Always make sure you have properly refitted (see page 79) and closed the plug after each refuelling.

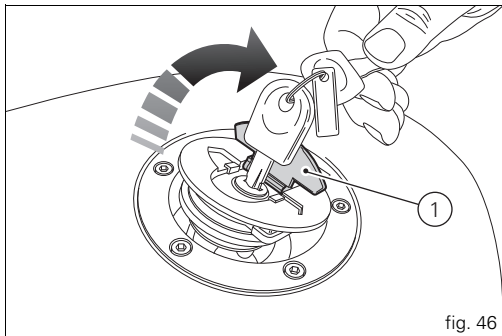
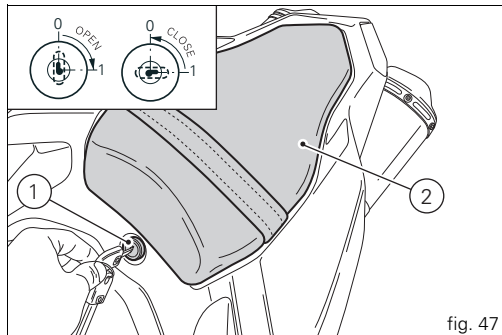

fig. 46

Seat lock

Opening (fig. 47)

Insert the key into the seat lock (1) and turn it clockwise until the seat catch disengages with an audible click.
Raise the rear of the seat (2) until it can be extracted.



Closing (fig. 48)

Insert the hooks (3) on the base of the seat under the rear subframe.
Push the passenger seat rear end until pin (4) clicks in place inside latch (5).
Pull the passenger seat moderately upwards to make sure it is correctly and firmly engaged.

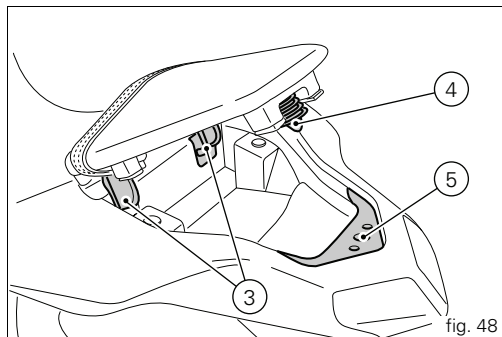

E Side stand (fig. 49)

Important

Before lowering the side stand, make sure that the bearing surface is hard and flat.

Do not park on soft or pebbled ground or on asphalt melt by the sun heat and similar or the motorcycle may fall over.

When parking in downhill road tracts, always park the motorcycle with its rear wheel facing downhill.

To lower the side stand, hold the motorcycle handlebars with both hands and, with your foot, push down the stand (1) until fully extended. Tilt the motorcycle until the side stand is resting on the ground.

Warning

Do not sit on the motorcycle when it is supported on the side stand.

To raise the side stand to rest position (horizontal), tilt the motorcycle to the right and, at the same time, lift the stand (1) with your foot.

Note

Check for proper operation of the stand mechanism (two springs, one into the other) and the safety sensor (2) at regular intervals.

Note

The engine can be started with the side stand down and the gearbox in neutral. If starting with a gear engaged, pull in the clutch lever (in this case the side stand must be up).

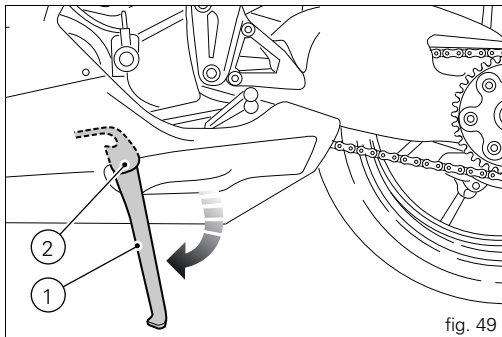
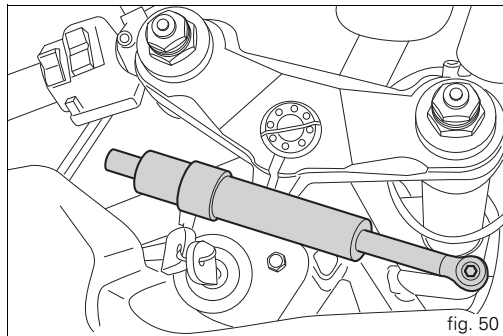

fig. 49

Steering damper (fig. 50)

It is located up front before the tank and is secured to frame and steering head.

It provides stable and accurate steering, improving the motorcycle's handling response under any conditions.



Front fork adjusters

The front fork used on this motorcycle has rebound, compression and spring preload adjustment.

This adjustment is done using the outer adjusters:

- 1) to adjust rebound damping (fig. 51);
- 2) to adjust spring preload (fig. 51);
- 3) to adjust compression damping (fig. 52).

Park the motorcycle in a stable position on its side stand. Turn the adjuster (1) on every fork leg top with a suitable wrench to adjust rebound damping.

As you turn the adjusting screws (1 and 3), you will hear them click. Each click identifies a setting. The stiffest damping setting is obtained with the adjuster turned fully clockwise to the "0" position. Start with this position and turn anticlockwise. Count the clicks, which correspond to position 1, 2 and so forth.

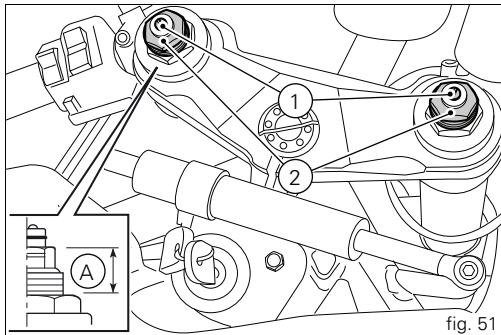

STANDARD factory setting is as follows:

Compression:

3/4 laps;

Rebound:

12 clicks.

Spring preload: (A, fig. 51): 18 mm.

To change the preload of the spring inside each fork leg, turn the hex. adjuster (2, fig. 51) with a 22-mm hexagon wrench.



Important

Adjust both fork legs to same settings.

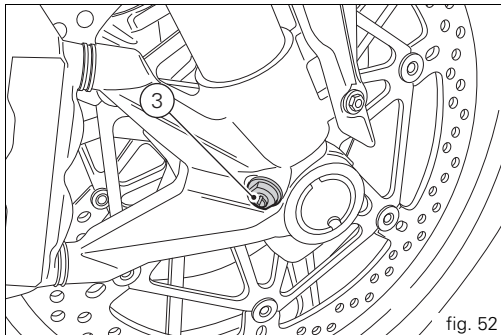

E Rear shock absorber adjusters (fig. 53)

The rear shock absorber has outer adjusters that enable you to adjust your motorcycle to the load.

The adjuster (1) on the left side of the connection holding the shock absorber to the swinging arm controls rebound damping.

The adjuster (2) on the shock absorber expansion reservoir controls compression damping.

Turning the adjusters (1 and 2) clockwise gives harder damping, turning anticlockwise gives softer damping.

STANDARD setting:

from fully closed (clockwise) loosen:

shim (1) by 2 laps

shim (2) by 2 laps

Spring preload: 20 mm.

Two ring nuts (3) located on the top section of the shock absorber are used to adjust the outer spring preload. To change spring preload, slacken off the upper ring nut. Then TIGHTEN or SLACKEN the lower ring nut to INCREASE or DECREASE spring preload.

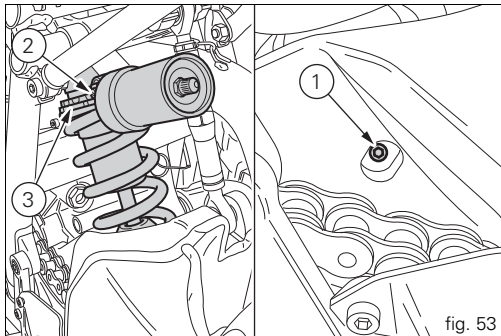

Once preload has been set as required, tighten the upper ring nut.



Warning

Use a specific pin wrench to turn the preload adjusting nut. Be careful when turning the nut with the wrench, as the pin may slip out of the ring nut recess and you may hurt your hand hitting motorcycle parts.



Warning

The shock absorber is filled with gas under pressure and may cause severe damage if taken apart by unskilled persons.

When carrying a passenger and luggage, set the rear shock absorber spring to proper preload to improve motorcycle handling and keep safe clearance from the ground. You may find that rebound damping needs adjusting as well.

Riding the motorcycle

For the first 100 km use the brakes gently. Avoid sudden or prolonged braking. This will allow the friction material on the brake pads to bed in against the brake discs.

For all mechanical parts of the motorcycle to adapt to one another and above all not to adversely affect the life of basic engine parts, it is advisable to avoid harsh accelerations and not to run the engine at high rpm for too long, especially uphill.

Furthermore, the drive chain should be inspected frequently. Lubricate as required.

Running-in recommendations

Maximum rpm (fig. 54)

Rotation speed for running-in period and during standard use (rpm):

- 1) up to 1000 km;
- 2) from 1000 to 2500 km.

Up to 1000 km

During the first 1000 km, keep an eye on the rev counter. It should never exceed 5,500÷6,000 rpm.

During the first hours of riding, it is advisable to run the engine at varying load and rpm, though still within recommended limit.

To this end, roads with plenty of bends and even slightly hilly areas are ideal for a most efficient running-in of engine, brakes and suspensions.

From 1000 to 2500 km

At this point, you can squeeze some more power out of your engine. However never exceed 7,000 rpm.

Important

During the whole running-in period, the maintenance and service rules recommended in the Warranty Card should be observed carefully. Failure to follow these instructions releases Ducati Motor Holding S.p.A. from any liability whatsoever for any engine damage or shorter engine life.

Strict observance of running-in recommendations will ensure longer engine life and reduce the likelihood of overhauls and tune-ups.

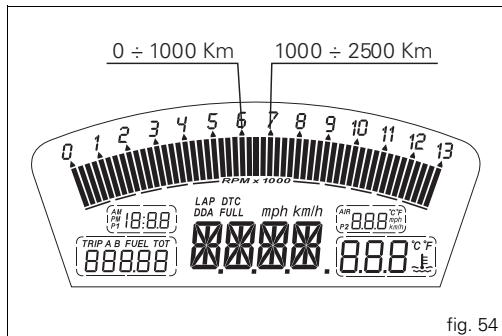

fig. 54

Pre-ride checks



Warning

Failure to carry out these checks before riding, may lead to motorcycle damage and injury to rider and passenger.

Before riding, perform a thorough check-up on your bike as follows:

FUEL LEVEL IN THE TANK

Check fuel level in the tank. Fill tank if needed (page 79).

ENGINE OIL LEVEL

Check oil level in the sump through the sight glass. Top up if needed (page 103).

BRAKE AND CLUTCH FLUID

Check fluid level in the relevant reservoirs (page 87).

COOLANT LEVEL

Check coolant level in the expansion reservoir. Top up if needed (page 86).

TYRE CONDITION

Check tyre pressure and condition (page 101).

CONTROLS

Work the brake, clutch, throttle and gear change controls (levers, pedals and twistgrip) and check for proper operation.

LIGHTS AND INDICATORS

Make sure lights, indicators and horn work properly. Replace any burnt-out bulbs (page 95).

KEY LOCKS

Ensure that fuel filler plug (page 64) and seat (page 65) are firmly secured.

SIDE STAND

Make sure side stand operates smoothly and is in the correct position (page 66).



Warning

In case of malfunction, do not ride the motorcycle and contact a Ducati Dealer or authorised Service Center.

Starting the engine



Warning

Before starting the engine, become familiar with the controls you will need to use when riding (page 10).



Warning

Never start or run the engine indoors. Exhaust gases are poisonous and may lead to loss of consciousness or even death within a short time.

1) Move the ignition key to ON (fig. 55). Make sure both the green light N and the red light  on the instrument panel come on.



Important

The oil pressure light should go out a few seconds after the engine has started (page 11).



Warning

The side stand must be fully up (in a horizontal position) as its safety sensor prevents engine start when down.

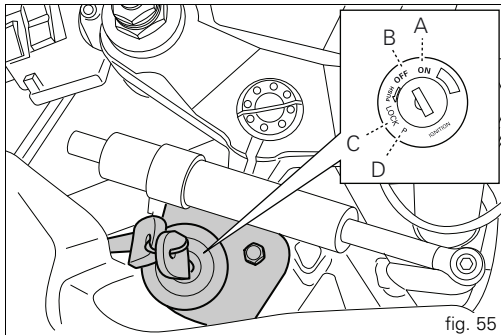

Note

It is possible to start the engine with side stand down and the gearbox in neutral. When starting the bike with a gear engaged, pull the clutch lever (in this case the side stand must be up).

E 2) Check that the stop switch (2, fig. 56) is positioned to  (RUN), then press the starter button (3, fig. 56).

 **Important**

Do not rev up the engine when it is cold. Allow some time for oil to reach all points that need lubricating.

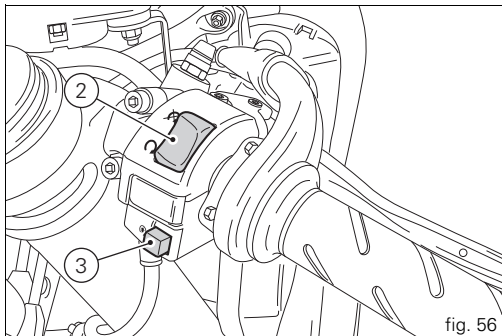

fig. 56

Moving off

- 1) Disengage the clutch by squeezing the clutch lever.
- 2) Push down the gear change lever firmly with the tip of your foot to engage first gear.
- 3) Raise the engine revs by turning the throttle twistgrip while gradually releasing the clutch lever. The motorcycle will start moving off.
- 4) Release the clutch lever completely and accelerate.
- 5) To shift up, close the throttle to slow down engine, disengage the clutch, lift the gear change lever and let go of clutch lever.

To shift down, proceed as follows: release the twistgrip, pull the clutch lever, shortly speed up to help gears synchronise, shift down (engage next lower gear) and release the clutch. The controls should be used correctly and timely: when riding uphill do not hesitate to shift down as soon as the motorcycle tends to slow down, so you will avoid stressing the engine and the motorcycle abnormally.



Important

Avoid harsh accelerations, as this may lead to misfiring and transmission snatching. The clutch lever should not be pulled longer than necessary after gear is engaged, or friction parts may overheat and wear out.

Braking

Slow down in time, shift down to engine-brake first and then brake applying both brakes. Pull the clutch lever before stopping the motorcycle, to avoid sudden engine stop.



Warning

Use both brake lever and pedal for effective braking. Never use the brake controls harshly or suddenly as you may lock the wheels and lose control of the motorcycle. When riding in the rain or on slippery surfaces, braking will become less effective. Always use the brakes very gently and carefully when riding under these conditions. Any sudden manoeuvres may lead to loss of control. When tackling long, high-gradient downhill road tracts, shift down gears to use engine braking. Apply one brake at a time and use brakes sparingly. Keeping the brakes applied all the time would cause the friction material to overheat and reduce braking power dangerously. Underinflated or overinflated tyres reduce braking efficiency, handling accuracy and stability in a bend.

Stopping the motorcycle

Reduce speed, shift down and release the throttle twistgrip. Shift down to engage first gear and then neutral. Apply the brakes and bring the motorcycle to a complete stop. To switch the engine off, simply turn the key to OFF (page 55).

Parking

Stop the motorcycle, then put it on the side stand (see page 66).

To prevent theft, turn the handlebar fully left and turn the ignition key to the LOCK position.

If you park in a garage or other indoor area, make sure that there is proper ventilation and that the motorcycle is not near a source of heat.

You may leave the parking lights on by turning the key to position P.



Important

Do not leave the key turned to P for long periods or the battery will run down. Never leave the ignition key in the switch when you are leaving your bike unattended.



Warning

The exhaust system might be hot, even after engine is switched off; pay particular attention not to touch exhaust system with any body part and do not park the vehicle next to inflammable material (wood, leaves etc.).



Warning

Using padlocks or other locks designed to prevent motorcycle motion, such as brake disc locks, rear sprocket locks, and so on is dangerous and may impair motorcycle operation and affect the safety of rider and passenger.

Refuelling (fig. 57)

Never overfill the tank when refuelling. Fuel should never be touching the rim of filler recess.



Warning

Use low-lead fuel with 95 octane rating at origin minimum (see “Top-ups” table, page 112).

Be sure there is no fuel trapped in the filler recess.



Warning (US version)

Use low-lead fuel with a minimum octane rating of 90 (RON+MON)/2 (see “Top-ups” table, page 112).



Warning

The vehicle is only compatible with fuel having a maximum content of ethanol of 10% (E10). Using fuel with ethanol content over 10% is forbidden. Using them could result in severe damage of the engine and motorcycle components. Using fuel with ethanol content over 10% will make the warranty null and void.

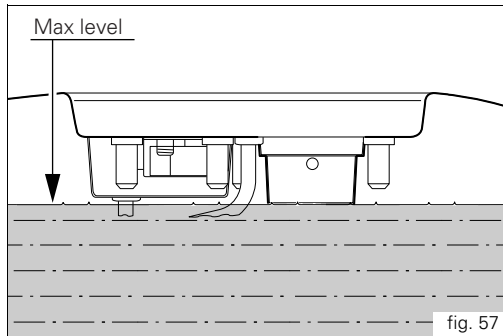

E Tool kit and accessories (fig. 58)

The compartment under the passenger seat holds:
owner's manual;

the tool kit, which includes:

- Box wrench for spark plugs;
- Tommy bar for plug wrench;
- Double-tip screwdriver;
- Allen wrench for fairings.

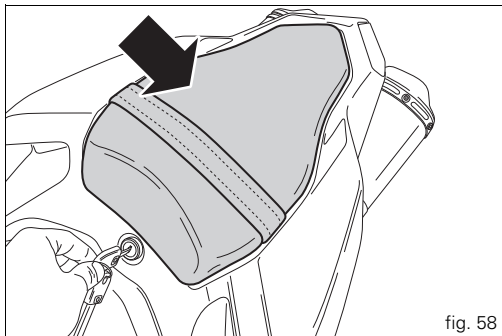

fig. 58

Main maintenance operations

Removing the fairing

Some parts of the motorcycle fairing have to be removed for certain maintenance or repair operations.

Warning

If parts that have been removed are not refitted correctly they may become loose suddenly while riding and cause you to lose control of your motorcycle.

Important

At reassembly always fit nylon washers when tightening fastening screws to avoid damage to painted parts and Plexiglas windscreen of headlight fairing.

Side fairings

To remove the fairings, use the Allen wrench accommodated under the seat to loosen the following:

the two screws (1) securing the fairing panels to the brackets;

the six screws (2) securing the fairing panels to the headlight fairing;

the four screws (3) securing the fairing panels to the frame;

the two screws (4) located under the fairing that join the right fairing panel to the left fairing panel;

the two screws (5) securing the fairing panels to the oil cooler;

the two screws (6, fig. 60) securing the front of the fairing to the headlight fairing.

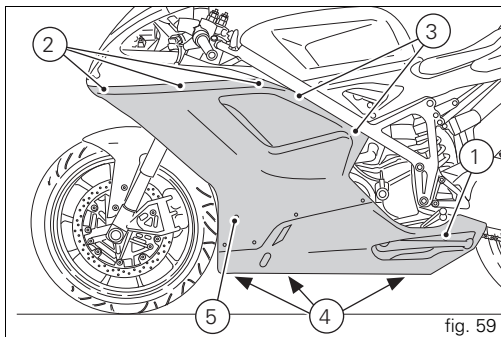

E



Note

Be careful of the splashguard, which is released by the fairing panel fastening.



Note

To refit the left fairing panel, lower the side stand and pass it through the hole in the panel.

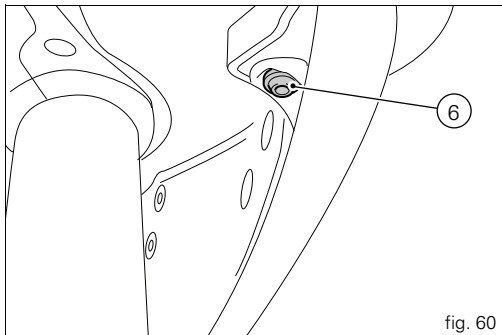

fig. 60

Rear-view mirrors

Unscrew the fastening screws (1) of the rear-view mirror. Release the pins (2) from the retaining clips (3) attached to the headlight fairing bracket (4). Slip off the rubber covers (5) and disconnect the turn indicator wiring connectors (6). Repeat the procedure to remove the other rear-view mirror.

Important

On refitting, apply medium-strength threadlocker to the threads of the screws (1).

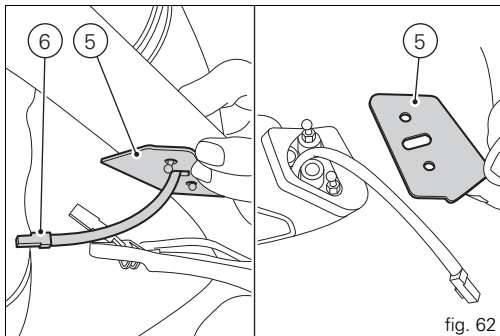
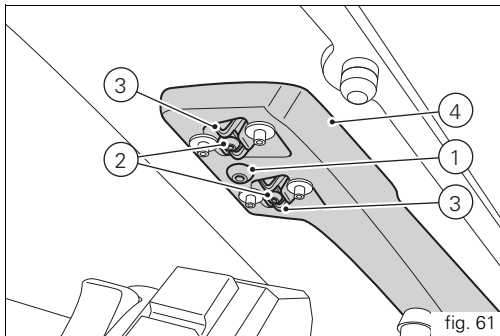

Kit to widen rear-view mirrors mounting

Remove the mirrors as previously explained. Unscrew the two screws (1) and remove the original spacer (2).

Fit the supplied spacer (3), start the two long screws (4) (supplied), then tighten them using a suitable Allen wrench. Reinstall the rear-view mirrors on the headlight fairing.

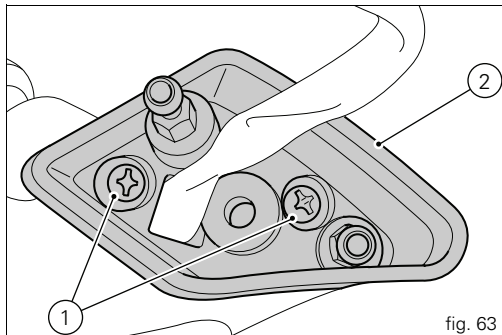

fig. 63

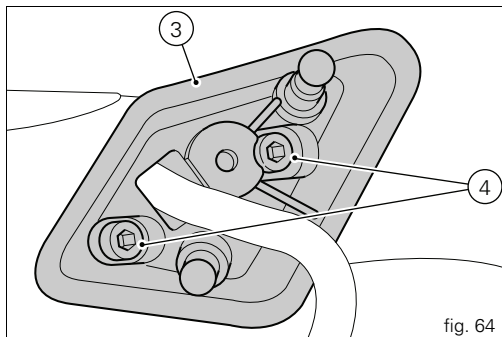

fig. 64

Headlight fairing



Note

To remove the headlight fairing, first remove the rear-view mirrors and side fairing panels as described above.

Unscrew the two rear screws (1) securing the headlight fairing to the headlight support.



Note

After refitting the headlight fairing, refit the side fairings and the rear-view mirrors.

Changing the air filter



Important

Have air filter serviced at a Ducati Dealer or authorised Service Centre.

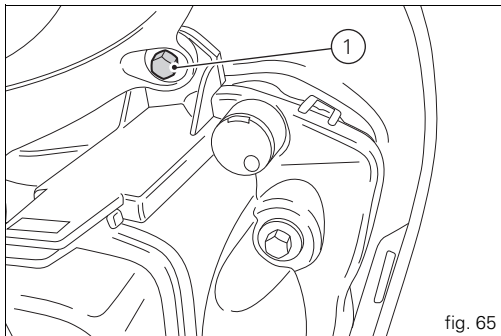

fig. 65

Checking and topping up coolant level

(fig. 66)

Check coolant level in the expansion tank on the right side of the vehicle. It should be between the two marks (1) and (2). Mark (2) indicates MAX level; mark (1) indicates MIN level. Top up if the level is below the MIN mark.

Remove the right-hand side fairing (see page 81). Unscrew the filler plug (3, fig. 66) and add a mixture consisting of water and antifreeze SHELL Advance Coolant or Glycoshell (35÷40% of the volume) up to MAX mark.

Refit the filler plug (3) and reassemble all removed parts. This type of mixture gives the best operating conditions (the coolant starts to freeze at -20 °C /-4 °F).

Cooling circuit capacity: 2.3 dm³ (litres).

Warning

Place the motorcycle upright on a flat surface and make sure the engine is cold before proceeding.

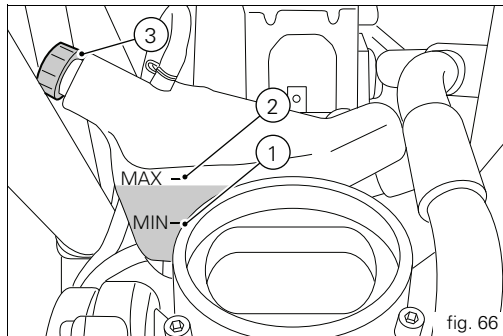

Checking brake and clutch fluid level

Level should never drop below the MIN marks on the tanks (fig. 67) (shown in the figure are the front and rear brake fluid reservoirs).

If level drops below the limit, air might get into the circuit and affect the operation of the system involved.

Fluids must be topped up and changed at the intervals specified in the scheduled maintenance table reported in the Warranty Booklet; please contact a Ducati Dealer or authorised Service Centre.

Important

It is recommended all brake and clutch lines be changed every four years.

Brake system

If you find excessive play on brake lever or pedal and brake pads are still in good condition, contact your Ducati Dealer or Authorised Service Centre to have the system inspected and any air drained out of the circuit.

Warning

Brake and clutch fluid can damage paintwork and plastic parts, so avoid contact. Hydraulic oil is corrosive; it may cause damage and lead to severe injuries. Never mix fluids of different qualities.

Check seals for proper sealing.

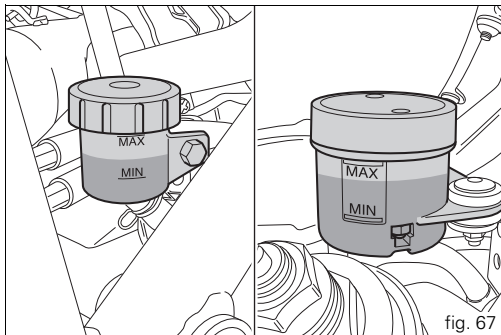

Clutch system

If the control lever has exceeding play and the transmission snatches or jams as you try to engage a gear, it means that there might be air in the circuit. Contact your Ducati Dealer or authorised Service Center to have the system inspected and air drained out.



Warning

Clutch fluid level will increase as clutch plate friction material wears down. Do not exceed the specified level (3 mm above the minimum level).

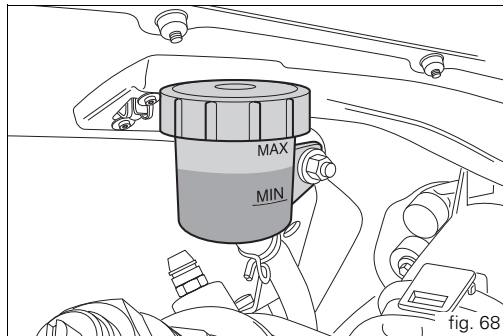

Checking brake pads for wear

(fig. 69 and fig. 70)

Check brake pads wear through the inspection hole in the callipers.

Change both pads if friction material thickness of even just one pad is about 1 mm.

Warning

Friction material wear beyond this limit would lead to metal support contact with the brake disc thus compromising braking efficiency, disc integrity and rider safety.

Important

Have the brake pads replaced at a Ducati Dealer or authorised Service Centre.

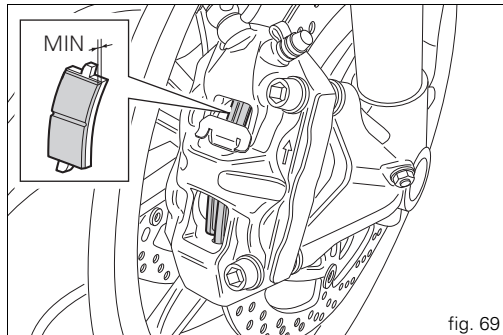

fig. 69

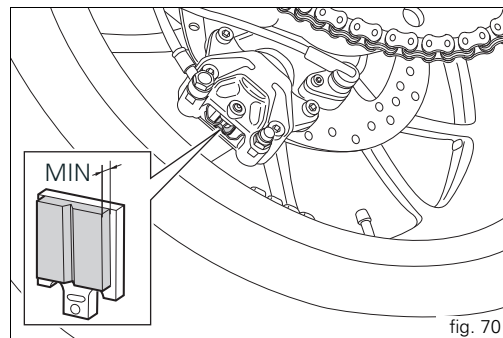

fig. 70

Lubricating cables and joints

Check the outer sheath of the throttle control cables for damage at regular intervals. The outer plastic cover should not be flattened or cracked. Work the controls to make sure the cables slide smoothly inside the sheaths: if you feel any friction or catching, have the cable replaced by a Ducati Dealer or Authorised Service Centre.

To avoid this kind of problem with the throttle cable, unscrew the two retaining screws (1, fig. 71) to open the case and then grease cable ends and pulley with SHELL Advance Grease or Retinax LX2 grease.



Warning

Close the case carefully after threading the cables onto the pulley.

Refit the cover and tighten the screws (1) to 10 Nm.

To ensure smooth operation of side stand joint, clean off any dirt and apply SHELL Alvania R3 at all points exposed to friction.

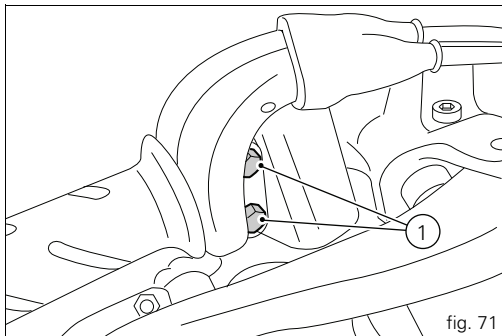
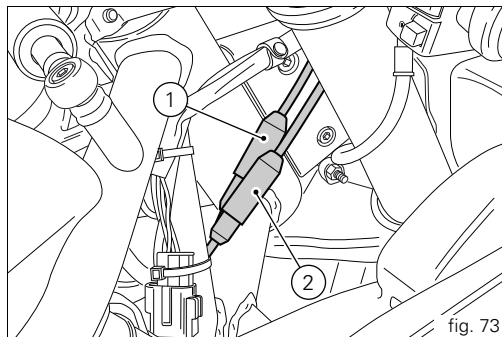
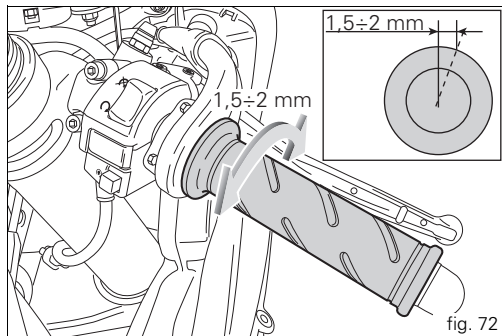

fig. 71

Adjusting throttle control free play

In all steering positions, the throttle twistgrip must have a free play of 1.5 - 2.0 mm, measured on the outer edge of the twistgrip. If necessary, adjust it using the adjusters (1 and 2, fig. 73) located on the steering tube on the right-hand side of the vehicle.

Adjuster (1) is for throttle opening, adjuster (2) for closing. Slip the rubber gaiters off the adjusters and slacken the lock nuts. Adjust both adjusters by the same amount: turn clockwise to increase free play and counter clockwise to reduce free play. When finished, tighten the check nuts and refit the rubber gaiters to the adjusters.



E Charging the battery (fig. 74)

Before charging the battery, it is best to remove it from the motorcycle.

Remove the left-hand side fairing (see page 81), unscrew the screw (1) and remove the bracket (2). Always disconnect the black negative terminal (-) first, then the red positive terminal (+).

Warning

The battery produces explosive gases: keep it away from heat sources.

Charge the battery in a ventilated room.

Connect the battery charger leads to the battery terminals: the red one to the positive terminal (+), the black one to the negative terminal (-).

Important

Make sure the charger is off when you connect the battery to it, or you might get sparks at the battery terminals that could ignite the gases inside the cells. Always connect the red positive (+) terminal first.

Reinstall the battery on its mount (3) and secure the bracket (2) with the screw (1). Apply some grease on the fastening screws to improve conductive capacity and connect the terminals.

Warning

Keep the battery out of the reach of children.

Charge the battery at 0.9 A for 5÷10 hours.

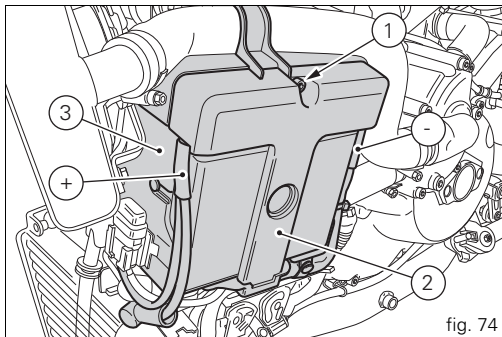

Checking drive chain tension (fig. 75)

Important

Have chain tension adjusted by a Ducati Dealer or authorised Service Centre.

Motorcycle (on side stand): place ruler at mid-way of chain lower section, push chain downwards and tension up until distance between the aluminium section of the swingarm and chain pin centre is 31 to 33 mm.

Warning

Correct tightening of tensioners check nuts (1) is critical to rider and passenger safety.

Important

Improper chain tension will lead to early wear of transmission parts.

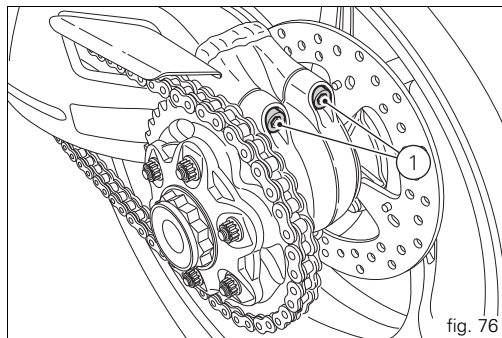
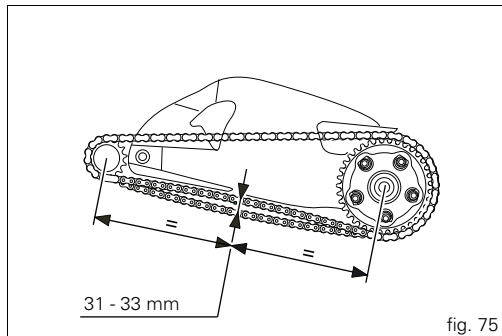

Chain lubrication

The chain fitted on your motorcycle has O-rings to protect its moving parts from dirt, and to hold the lubricant inside.

The seals might be irreparably damaged if the chain is cleaned using any solvent other than those specific for O-ring chains or washed using steam or water cleaners.

After cleaning, blow the chain dry or dry it using absorbent material and apply SHELL Advance Chain or Advance Teflon Chain on each link.

Important

Using non-specific lubricants may lead to severe damage to chain, front and rear sprocket.

Replacing the high and low beam bulbs

Before replacing a burnt-out bulb, make sure that the new one matches the voltage and wattage specifications in the "Electric System" paragraph on page 119. Always test the new bulb before refitting any parts you have removed. Shown in fig. 77 are the locations of the low beam bulb (LO), high beam bulb (HI) and parking light bulb (1).

Headlight

To gain access to the left-hand bulb, remove the cover (2) by pressing the lever (A).

Rotate the locking ring nut (3) of the upper bulb body anti-clockwise and extract the burnt-out bulb. Replace with a bulb of equal rating.

On refitting, rotate the locking ring nut (3) clockwise to secure the bulb in place.

The right-hand bulb is replaced in the same way.

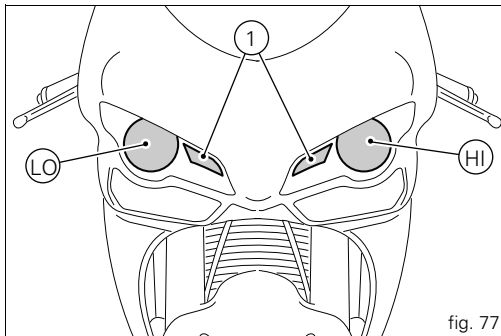

fig. 77

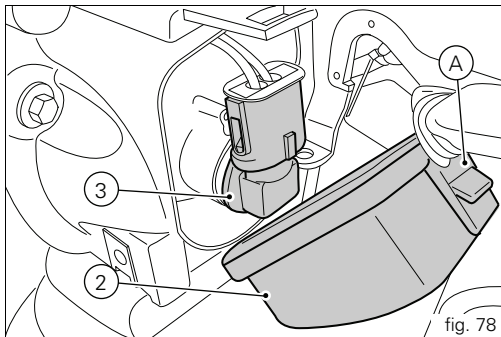

fig. 78



Note

To replace the headlight bulbs, there is no need to disconnect the main wiring harness from the headlight bulb holder.



Note

Be careful to hold the new bulb at the base only. Never touch the transparent body with your fingers or it will blacken resulting in reduced bulb brilliancy.

Refitting

After changing the burnt-out bulb, replace the cover and close it by pressing it against the lever.

Replacing the parking light bulb

To gain access to the parking light bulbs (1), insert your hand into the light support and extract the bulb holders from their seat; turn the bulb ring nut (1) counter clockwise and extract the burnt-out bulb.

Renew the burnt-out bulb.

On refitting, turn the bulb (1) clockwise to secure it.

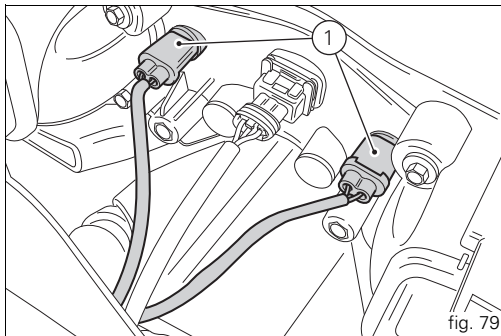

Rear turn indicators (fig. 80)

To change the rear turn indicator bulbs, rotate the indicator body (1) through one quarter of a turn so that the lens is up and extract indicator body from the indicator light unit. The bulb is of the banjo-type: press and rotate anticlockwise to remove;. Fit the spare bulb by pressing and turning clockwise until it clicks. Refit the indicator body (2) to its support and rotate it by a quarter of a turn.

Number plate light (fig. 81)

To access the number plate light bulb, unscrew the screw (3) securing the cover (4). Remove the bulb and replace it.

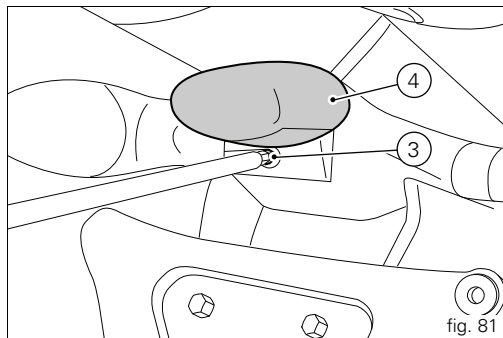
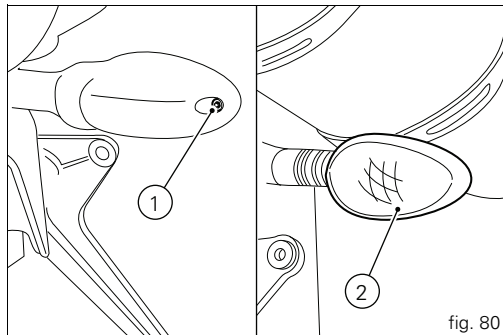

Beam setting (fig. 82)

To check the headlight aim, place the motorcycle upright with the tyres inflated to the correct pressure and one person sitting astride the motorcycle. The motorcycle should be perfectly vertical, with its longitudinal axis at right angles to a wall or screen at a distance of 10 metres. then draw a horizontal line dictated by headlamp centre and a vertical one in line with the longitudinal axis of motorcycle.

If possible, perform this check in dim light.

Switch on the low beam.

The height of the light spot (measured at the upper limit between dark and lighted-up area) should not exceed 9/10th of the height from ground of headlamp centre.



Note

This is the procedure specified by Italian regulations for checking the maximum height of the light beam.

Owners in other countries will adapt said procedure to the provisions in force in their countries.

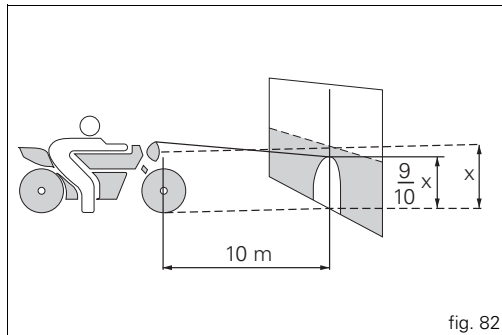

The side position of the left beam can be corrected using the screw (1, fig. 83) on the rear side of the headlamp. Turn the screw clockwise to move the beam to the right, counter clockwise to move it to the left.

The height of the left beam can be corrected using the screw (2, fig. 83) on the rear side of the headlamp. Turn the screw clockwise to lower the beam, anticlockwise to raise it.

Repeat the above procedure to adjust the right-hand headlamp.



Warning

The headlight might fog up if the vehicle is used under the rain or after washing.

Switch headlight on for a short time to dry up any condensate.

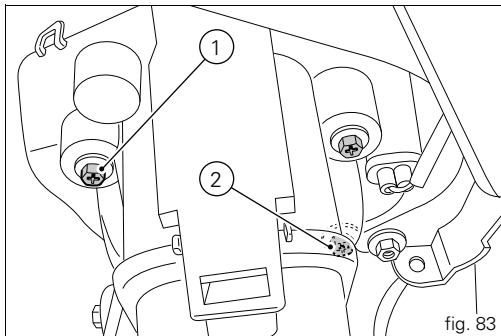

Rear-view mirror adjustment (fig. 84)

The rear-view mirror can be adjusted manually by pressing on point (A).

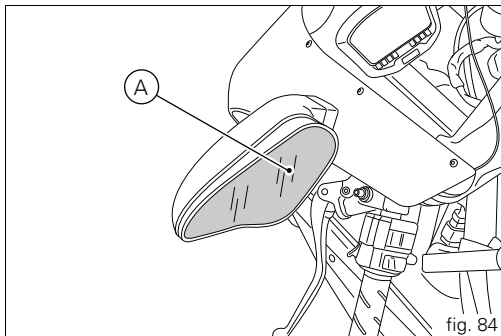

Tubeless tyres

Front tyre pressure:

2.1 bar - 2.3 Kg/sq. cm

Rear tyre pressure:

2.2 bar - 2.4 Kg/sq. cm

As tyre pressure is affected by temperature and altitude variations, you are advised to check and adjust it whenever you are riding in areas where ample variations in temperature or altitude occur.



Important

Check and adjust the pressures with the tyres cold. To avoid front wheel rim distortion, when riding on bumpy roads, increase tyre pressure by 0.2 - 0.3 bar.

Tyre repair or change (Tubeless tyres)

In the event of a tiny puncture, tubeless tyres will take a long time to deflate, as they tend to keep air inside. If you find low pressure on one tyre, check the tyre for punctures.



Warning

Punctured tyres must be replaced. Replace tyres with recommended standard tyres only. Be sure to tighten the valve caps securely to avoid leaks when riding. Never use tube type tyres. Failure to heed this warning may lead to sudden tyre bursting and to serious danger to rider and passenger.

After replacing a tyre, the wheel must be balanced.



Important

Do not remove or shift the wheel balancing weights.



Note

Have the tyres replaced at a Ducati Dealer or authorised Service Center. Correct removal and installation of the wheels is essential.

Minimum tread depth

Measure tread depth (S, fig. 85) at the point where tread is most worn down.

It should not be less than 2 mm, and in any case not less than the legal limit.

Important

Visually inspect the tyres at regular intervals for detecting cracks and cuts, especially on the side walls, bulges or large spots that are indicative of internal damage. Replace them if badly damaged. Remove any stones or other foreign bodies caught in the tread.

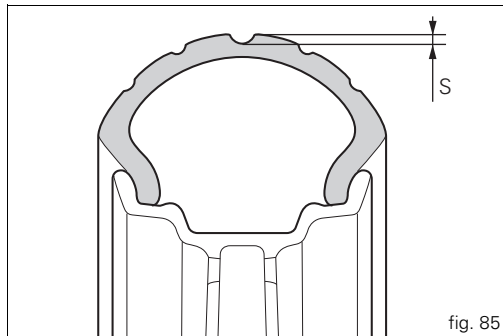

Checking engine oil level (fig. 86)

Engine oil level can be checked through the sight glass (1) provided on the clutch cover. Oil level must be checked with the motorcycle perfectly upright and the engine cold. Oil level should be between the marks on the sight glass. If the level is low, top up with SHELL Advance 4T Ultra engine oil. Remove the oil filler cap (2) and top up until the oil reaches the required level. Refit the plug.



Important

Engine oil and oil filters must be changed by a Ducati Dealer or authorised Service Center at the intervals specified in the scheduled maintenance chart reported in the Warranty Card.

Viscosity

SAE 15W-50

The other viscosity degrees indicated in the table can be used if the local average temperature is within the limits specified for that oil viscosity.

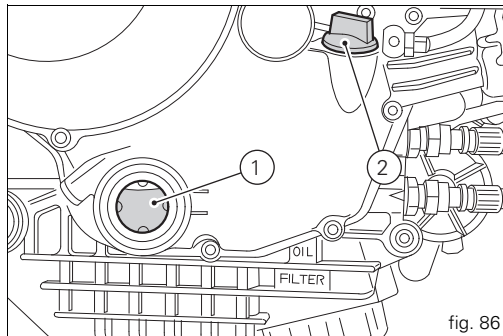
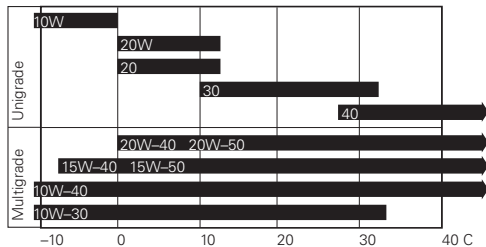

fig. 86



E Cleaning and replacing the spark plugs (fig. 87)

Spark plugs are essential to smooth engine running and should be checked at regular intervals.

This operation provides an indication of engine condition.

Have the spark plugs inspected or renewed at a Ducati Dealer or Authorised Service Centre. Firstly, they will check the colour of the ceramic insulator of the central electrode: a uniform light brown colour indicates good engine condition.



Note

Inspect the centre electrode for wear and check spark plug gap, which should be:

0.8-0.1 mm.



Important

A gap outside the specified limits will adversely affect engine performance and may lead to difficult starting or erratic idling.

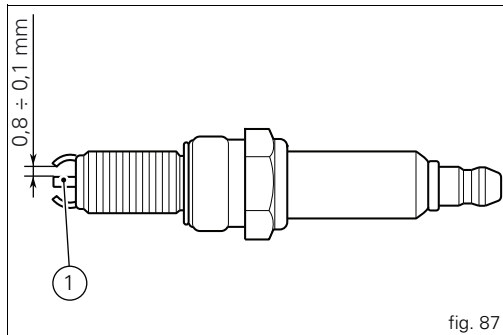

fig. 87

Cleaning the motorcycle

To preserve the finish of metal parts and paintwork, wash and clean your motorcycle at regular intervals, anyway according to the road conditions you ride in. Use specific products only. Prefer biodegradable products. Avoid aggressive detergents or solvents.

Only use water and neutral soap to clean the Plexiglas and the seat.

Periodically manually clean all aluminium components. Use special detergents, suitable for aluminium parts FREE of abrasives or caustic soda.



Note

Do not use sponges with abrasive parts or steel wool: only use soft cloths.

However, the warranty does not apply to motorcycles whenever poor maintenance status is ascertained.



Important

Do not wash your motorcycle right after use. When the motorcycle is still hot, water drops will evaporate faster and spot hot surfaces. Never clean the motorcycle using hot or high-pressure water jets. Cleaning the motorcycle with a high pressure water jet may lead to seizure or serious faults in the front fork, wheel hub assembly, electric system, headlight (fogging), front fork seals, air inlets or exhaust silencers, with consequent loss of compliance with the safety requirements.

Clean off stubborn dirt or exceeding grease from engine parts using a degreasing agent. Be sure to avoid contact with drive parts (chain, sprockets, etc.). Rinse with warm water and dry all surfaces with chamois leather.



Warning

Braking performance may be impaired immediately after washing the motorcycle. Never grease or lubricate the brake discs. Loss of braking and further accidents may occur. Clean the discs with an oil-free solvent.



Warning

The headlight might fog up due to washing, rain or moisture. Switch headlight on for a short time to dry up any condensate.

Storing the bike away

If the motorcycle is to be left unriden over long periods, it is advisable to carry out the following operations before storing it away:

clean the motorcycle;

empty the fuel tank;

pour a few drops of engine oil into the cylinders through the spark plug bores, then turn the engine over by hand a few times to form a protective film of oil on the inner walls of the cylinder;

place the motorcycle on the service stand;

disconnect and remove the battery.

Battery should be checked and charged (or replaced, as required) whenever the motorcycle has been left unriden for over a month.

Protect the motorcycle with a suitable canvas. This will protect paintwork and let condensate breathe out.

The canvas is available from Ducati Performance.

Important notes

The legislation in some countries (France, Germany, Great Britain, Switzerland, etc.) sets certain noise and pollution standards.

Periodically carry out the required checks and replace parts as necessary, using Ducati original spare parts, in compliance with the regulations in the country concerned.

Maintenance

Scheduled maintenance chart: operations to be performed by the dealer

List of operations and type of intervention [set mileage (km/mi) or time interval *]	Km. x1000	1	12	24	36	48	60
	mi. x1000	0.6	7.5	15	22.5	30	37.5
	Months	6	12	24	36	48	60
Change engine oil		●	●	●	●	●	●
Change engine oil filter		●	●	●	●	●	●
Clean engine oil filter at intake					●		
Check engine oil pressure				●		●	
Check/adjust the valve clearances (1)			●	●	●	●	●
Check the tension of the timing belts (1)			●		●		●
Replace the timing belts				●		●	
Replace the spark plugs			●	●	●	●	●
Check and clean air filter (1)			●		●		●

List of operations and type of intervention [set mileage (km/mi) or time interval *]	Km. x1000	1	12	24	36	48	60
	mi. x1000	0.6	7.5	15	22.5	30	37.5
	Months	6	12	24	36	48	60
Changing air filter				●		●	
Check throttle body synchronisation and idling (1)			●	●	●	●	●
Check brake and clutch fluid level		●	●	●	●	●	●
Change brake and clutch fluid					●		
Check and adjust brake and clutch controls			●	●	●	●	●
Check / lubricate throttle / cold start controls			●	●	●	●	●
Check tyre pressure and wear		●	●	●	●	●	●
Check brake pads. Replace if necessary		●	●	●	●	●	●
Check steering bearings				●		●	
Check chain tension, alignment and lubrication		●	●	●	●	●	●
Check clutch plates pack. Change, if necessary (1)			●	●	●	●	●
Check the coolant level			●	●	●	●	●
Change the coolant					●		
Check electric fan operation and cooling circuit sealing			●	●	●	●	●
Check rear wheel flexible coupling				●		●	
Check wheel hub bearings				●		●	
Check the indicators and lighting			●	●	●	●	●
Check tightening of nuts securing engine-to-frame screws			●	●	●	●	●
Check the side stand			●	●	●	●	●

List of operations and type of intervention [set mileage (km/mi) or time interval *]	Km. x1000	1	12	24	36	48	60
	mi. x1000	0.6	7.5	15	22.5	30	37.5
	Months	6	12	24	36	48	60
Check front wheel nut tightening			●	●	●	●	●
Check rear wheel nut tightening			●	●	●	●	●
Check external fuel lines			●	●	●	●	●
Change the front fork fluid					●		
Check front fork and rear shock absorber for leakage			●	●	●	●	●
Check front sprocket fasteners			●	●	●	●	●
Lubricate and grease			●	●	●	●	●
Check battery and recharge			●	●	●	●	●
Road test of the motorcycle		●	●	●	●	●	●
Cleaning the motorcycle			●	●	●	●	●

* Service on the set interval, whichever comes first (mileage or months)

(1) Operation to be performed only if set mileage (km/mi) is reached

Scheduled maintenance chart: operations to be performed by the customer

List of operations and type of intervention [set mileage (km/mi) or time interval *]	Km. x1000	1
	mi. x1000	0.6
	Months	6
Check engine oil level		●
Check brake and clutch fluid level		●
Check tyre pressure and wear		●
Check the drive chain tension and lubrication		●
Check brake pads. If necessary, contact your dealer to replace pads		●

* Service on the set interval, whichever comes first (mileage or months)

Technical data

Weight in running order without fluids and battery

168 kg.

Carrying full load:

390 kg.

E

Overall dimensions (mm) (fig. 88)

Weights

Weight in running order without fuel:

184 kg.



Warning

Failure to observe weight limits could result in poor handling and impair the performance of your motorcycle, and you may lose control of the motorcycle.

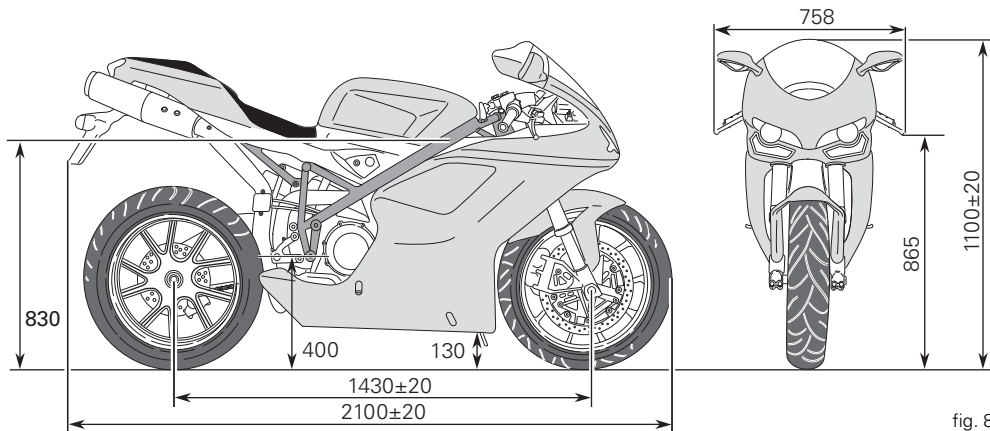

fig. 88

TOP-UPS	TYPE	
Fuel tank, including a reserve of 4 cu. dm (litres)	Unleaded fuel with a minimum octane rating of RON 95. For the US version, use unleaded fuel with a minimum octane rating of 90 (RON+MON)/2.	15.5 cu. dm (litres)
Lubrication circuit	SHELL - Advance 4T Ultra	3.7 cu. dm (litres)
Front/rear brake and clutch circuits	Special hydraulic fluid SHELL Advance Brake Dot 4	—
Protectant for electric contacts	SHELL - Advance Contact Cleaner spray for electric systems	—
Front fork	SHELL - Advance Fork 7.5 or Donax TA	439 cc (per leg)
Cooling circuit	Antifreeze SHELL - Advance Coolant or Glycoshell 35-40% + water	2.3 cu. dm (litres)



Important

Do not use any additives in fuel or lubricants. Using them could result in severe damage of the engine and motorcycle components.



Warning

The vehicle is only compatible with fuel having a maximum content of ethanol of 10% (E10). Using fuel with ethanol content over 10% is forbidden. Using them could result in severe damage of the engine and motorcycle components. Using fuel with ethanol content over 10% will make the warranty null and void.

Engine

Longitudinal 90° "L" twin cylinder, four-stroke.

Bore, mm:

94

Stroke, mm:

61.2

Total displacement, cu. cm:

849.4

Compression ratio:

13.2 ±0.5:1.

Max crankshaft power (95/1/EC), kW/HP:

103 kW/140 HP at 10,500 rpm

Max torque at crankshaft (95/1/EC):

98 Nm at 9,750 rpm

Maximum rpm:

11.300



Important

Do not exceed the specified rpm limits in any running conditions.

Timing system

DESMODROMIC (type) with four valves per cylinder, operated by eight rocker arms (4 opening rockers and 4 closing rockers) and two overhead camshafts. It is operated by the crankshaft through spur gears, belt rollers and toothed belts.

Desmodromic timing system (fig. 89)

- 1) Opening (or upper) rocker.
- 2) Opening rocker shim.
- 3) Closing (or lower) rocker shim.
- 4) Return spring for lower rocker.
- 5) Closing (or lower) rocker.
- 6) Camshaft.
- 7) Valve.

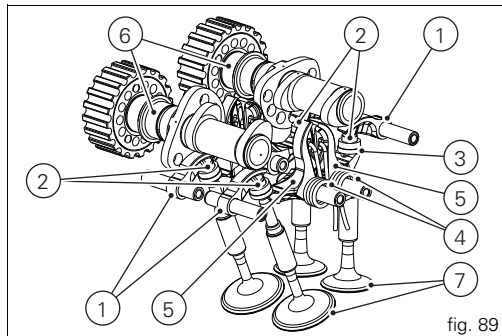

fig. 89

Performance data

Maximum speed in any gear should be reached only after a correct running-in period with the motorcycle properly serviced at the recommended intervals.

Spark plugs

Make:

NGK

Type:

MAR10A-J

Fuel system

MARELLI indirect electronic fuel injection.

Oval section throttle body diameter:

56 mm

Injectors per cylinder: 1

Firing points per injector: 12

Fuel specifications: 95-98 RON.



Warning

Use a minimum octane rating of 90 (RON+MON)/2.



Warning

The vehicle is only compatible with fuel having a maximum content of ethanol of 10% (E10). Using fuel with ethanol content over 10% is forbidden. Using them could result in severe damage of the engine and motorcycle components. Using fuel with ethanol content over 10% will make the warranty null and void.

Brakes

Front

Semi-floating drilled twin-disc.

Braking material:
steel.

Carrier material:
aluminium.

Disc diameter:
330 mm.

Hydraulically operated by a control lever on right handlebar.

Brake caliper make:
BREMBO.

Type:
34-4 pistons.

M4-34.
Friction material:

TT 2172.

Master cylinder type:
PR18/19.

Rear

With fixed drilled steel disc.

Disc diameter:
245 mm.

Hydraulically operated by a pedal on RH side.

Make:
BREMBO.

Type:
P34c pistons.

Friction material:
FERIT I/D 450 FF.

Master cylinder type:
PS 11 b.



Warning

The brake fluid used in the brake system is corrosive. In the event of accidental contact with eyes or skin, wash the affected area with abundant running water.

Transmission

Dry clutch operated by a control lever on left handlebar.
Drive is transmitted from engine to gearbox main shaft via spur gears.

Front chain sprocket/clutch gearwheel ratio:
33/61

6-speed gearbox with constant mesh gears, gear change pedal on left side of motorcycle.

Gearbox output sprocket/rear chain sprocket ratio:
15/39

Total gear ratios:

1st gear 15/37

2nd gear 17/30

3rd gear 20/28

4th gear 22/26

5th gear 23/24

6th gear 24/23

Drive chain from gearbox to rear wheel:

Make:

RK

Type:

525 GXW IMPROVED

Dimensions:

5/8" x 1/16"

Links:

98.

Important

The above gear ratios are the homologated ones and under no circumstances must they be modified.

However, if you wish to tune up your motorcycle for competitions or special tracks, Ducati Motor Holding S.p.A. will be pleased to provide information about the special ratios available. Contact a Ducati Dealer or Authorised Service Center.

Warning

If the rear sprocket needs replacing, contact a Ducati Dealer or authorised Service Center. If improperly replaced, this component could seriously endanger your safety and cause irreparable damage to your motorcycle.

Frame

ALS450 steel tube trellis frame.

ALS450 steel tube trellis rear subframe.

Steering angle (on each side):

28° 30'.

Steering head angle: 24°30'

Trail:

97 mm

Wheels

Five Y-spokes, light-alloy rims.

Front

Dimensions:

MT 3.50x17".

Rear

Dimensions:

MT 5.50x17".

Both wheel shafts can be removed.

Tyres

Front

Radial tubeless tyre.

Size:

120/70-ZR17

Rear

Radial tubeless tyre.

Size:

180/55-ZR17

Suspensions

Front

Hydraulic upside-down fork provided with outer adjusters for rebound, compression, and preload (for inner springs of fork legs).

Stanchion diameter:

43 mm.

Travel along leg axis:

127 mm.

Rear

Of the progressive type, thanks to a rocker arm connecting frame and upper pivot point of the shock absorber.

The shock absorber allows rebound, compression damping and spring preload adjustment and is connected to a light alloy swingarm at the bottom pivot point. The swinging arm rotates around a pivot shaft that passes through frame and engine.

The whole system gives the bike excellent stability.

Shock absorber stroke:

59.5 mm.

Wheel travel:

120 mm.

Exhaust system

Equipped with catalytic converter.

Available colours

Ducati Anniversary red 473.101 (PPG);

Bright black 248.514 (PPG);

White polyurethane primer 490.019 (PPG);

Deltron clear lacquer D880 228.880 (PPG);

red frame and black rims.

Electrical system

The main components of the electric system are:

Headlight:

bulb type: 2 x H11 (12V-55W).

parking light:

bulb type: 2 x H16W (12V-6W).

Electrical controls on handlebars:

Turn indicators:

Front: LED

Rear: BULB TYPE: R10W (12V-10W) ORANGE

Horn.

Stop light switches.

Battery 12V-10 Ah.

GENERATOR 12V-480W.

ELECTRONIC RECTIFIER, protected with a 30A fuse on the side of the battery.

Starter motor, 12V-0.7 kW.

Tail light and brake signal:

led.

Number plate light:

bulb type: W5W (12-5W).



Note

For bulb replacement instructions, please read on page 95 the relevant paragraph "Replacing bulbs".

Fuses

Electrical parts are protected by nine fuses housed inside special fuse boxes. Only 7 fuses are connected. There are two spare fuses.

Refer to the table below to identify the circuits protected by the various fuses and their ratings.

LEGEND TO FUSE BOX (1, fig. 90)

Pos.	El. item	Rat.
1	Key-on	10 A
2	Lights	15 A
3	El. item	15 A
4	Instrument panel	5 A
5	Injection	20 A
6	ECU	5 A
7	Fans	7.5 A

The main fuse box (1, fig. 90) is located on the left side of the frame. To expose the fuses, take off the box protective cover. Mounting position and ampere capacity are marked on box cover.

The fuse (2) protects the electronic regulator. Remove the protective cap to access the fuses.

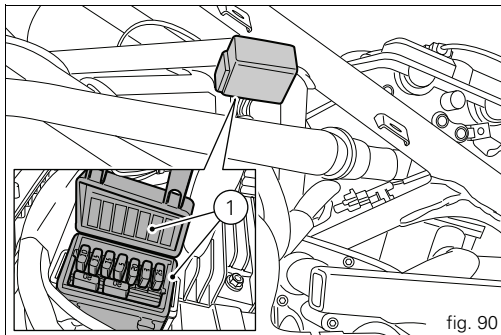

fig. 90

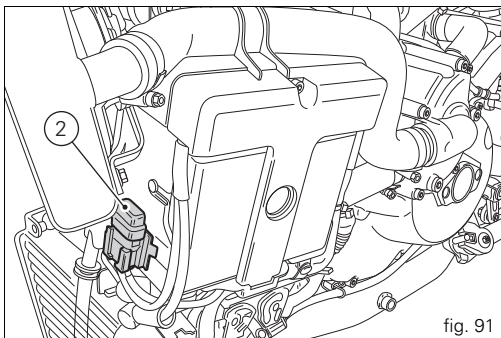

fig. 91

A blown fuse is identified by the interrupted centre link (3, fig. 92).



Important

Switch the ignition key to OFF before replacing the fuse to avoid possible short-circuits.



Warning

Never use a fuse with a rating other than specified. Failure to observe this rule may damage the electric system or even cause fire.

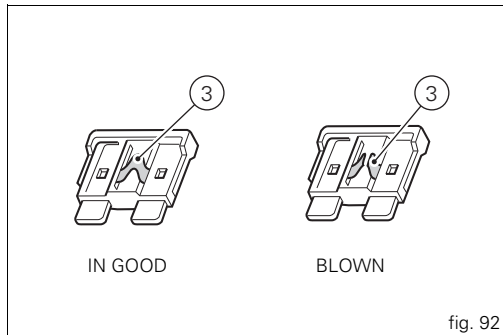

Injection /electric system diagram key

- | | |
|------------------------------------|-----------------------------|
| 1) Right-hand switch | 31) Neutral switch |
| 2) Ignition switch | 32) Oil pressure switch |
| 3) LH fan | 33) Rear stop switch |
| 4) RH fan | 34) ECU |
| 5) Starter motor | 35) Fuses |
| 6) Solenoid starter | 36) Clutch switch |
| 7) Battery | 37) Front stop switch |
| 8) Regulator fuse | 38) Left-hand switch |
| 9) Regulator | 39) Transponder antenna |
| 10) Generator | 40) Air temperature sensor |
| 11) RH rear turn indicator | 41) Finish line |
| 12) Tail light | 42) Dashboard |
| 13) Number plate light | 43) Light relay |
| 14) LH rear turn indicator | 44) LH front turn indicator |
| 15) Fuel tank | 45) Headlight |
| 16) Stepper motor | 46) Front RH parking light |
| 17) Injection relay | 47) RH front turn indicator |
| 18) Self-diagnosis | 48) EX-UP drive |
| 19) Horizontal cylinder coil | 49) Fan relay |
| 20) Vertical cylinder coil | 50) Front LH parking light |
| 21) Horizontal cylinder spark plug | 51) Data logger |
| 22) Vertical cylinder spark plug | 52) Lambda sensor 1 |
| 23) Horizontal cylinder injector | 53) - |
| 24) Vertical cylinder injector | 54) - |
| 25) Throttle position sensor | 55) Lambda sensor 2 |
| 26) Timing/rpm sensor | 56) Ignition relay |
| 27) Water temperature sensor | 57) DTC |
| 28) Rear speed sensor | 58) Front speed sensor |
| 29) Side stand | 59) Quick shifter |
| 30) Horn | |

Wire colour coding

B Blue
W White
V Violet
BK Black
Y Yellow
R Red
LB Light blue
GR Grey
G Green
BN Brown
O Orange
P Pink



Note

The electric system wiring diagram is at the end of this manual.

Routine maintenance record

KM	DUCATI SERVICE	MILEAGE	DATE
1000			
12000			
24000			
36000			
48000			
60000			

For United States of America version Only

Reporting of safety defects

If you believe that your vehicle has a defect which could cause a crash or could cause injury or death, you should immediately inform the National Highway Traffic Safety Administration (NHTSA) in addition to notifying Ducati North America. If NHTSA receives similar complaints, it may open an investigation, and if it finds that a safety defect exists in a group of vehicles, it may order a recall and remedy campaign. However, NHTSA cannot become involved in individual problems between you, your dealer, or Ducati North America. To contact NHTSA, you may either call the Auto Safety Hotline toll-free at 1-800-424-9393 (or 366-0123 in Washington, D.C. area) or write to: NHTSA, 1200 New Jersey Avenue SE W43-488, Washington, D.C. 20590. You can also obtain other information about motor vehicle safety from the Hotline.

Safety warnings

Traffic Rules vary from jurisdiction to jurisdiction. Know the regulations in your jurisdiction before riding this motorcycle.



Warning

This motorcycle is designed and intended for use on streets and other smooth, paved areas only. Do not use this motorcycle on unpaved surfaces. Such use could lead to upset or other accident.

Noise emission warranty

Ducati Motor S.p.A. warrants that this exhaust system, at the time of sale, meets all applicable U.S. EPA Federal noise standards. This warranty extends to the first person who buys this exhaust system for purposes other than resale, and to all subsequent buyers. Warranty claims should be directed to: Ducati North America, 10443 Bandlely Drive, Cupertino, California, 95014 Tel: 001.408.253.0499 - Fax: 001.408.253.4099.

Noise and exhaust emission control system information

Source of Emissions

The combustion process produces carbon monoxide and hydrocarbons. Control of hydrocarbons is very important because under certain conditions, they react to form photochemical smog when subjected to sunlight.

Carbon monoxide does not react in the same way, but is toxic. Ducati utilizes lean carburetor settings and other systems to reduce carbon monoxide and hydrocarbons.

Exhaust Emission Control System

The Exhaust Emission Control System is composed of lean carburetor settings, and no adjustments should be made except idle speed adjustments with the throttle stop screw. The Exhaust Emission Control System is separate from the crankcase emission control system.

Crankcase Emission Control System

The engine is equipped with a closed crankcase system to prevent discharging crankcase emissions into the atmosphere. Blow-by gas is returned to the combustion chamber through the air cleaner and the throttle body.

Evaporative Emission Control System

California motorcycles are equipped with an evaporative emission control system which consists of a charcoal canister and associated piping. This system prevents the escape of fuel vapors from the throttle body and fuel tank.

Tampering warning

Tampering with Noise Control System Prohibited. Federal Law prohibits the following acts or causing thereof:

(1) the removal or rendering inoperative by any person, other than for purposes of maintenance, repair, or replacement, of any device or element of design incorporated into any new vehicle for the purpose of noise control prior to its sale or delivery to the ultimate purchaser or while it is in use; or

(2) the use of the vehicle after such device or element of design has been removed or rendered inoperative by any person.

Among those acts presumed to constitute tampering are the acts listed below:

- (1) Removal of, or puncturing the muffler, baffles, header pipes or any other component which conducts exhaust gases.
- (2) Removal or puncturing of any part of the intake system.
- (3) Lack of proper maintenance.
- (4) Replacing any moving part of the vehicle, or parts of the exhaust or intake system, with parts other than those specified by the manufacturer.

This product should be checked for repair or replacement if the motorcycle noise has increased significantly through use. Otherwise, the owner may become subject to penalties under state and local ordinances.

Problems that may affect motorcycle emissions

If you are aware of any of the following symptoms, have the vehicle inspected and repaired by your local Ducati dealer.

Symptoms:

- Hard starting or stalling after starting.
- Rough idle.
- Misfiring or backfiring during acceleration.
- After-burning (backfiring).
- Poor performance (driveability) and poor economy.

Riding safety

The points given below are applicable for every day motorcycle use and should be carefully observed for safe and effective vehicle operation.

A motorcycle does not provide the impact protection of an automobile, so defensive riding in addition to wearing protective apparel is extremely important.

Do not let protective apparel give you a false sense of security.

Before changing lanes, look over your shoulder to make sure the way is clear. Do not rely solely on the rear view mirror; you may misjudge a vehicle's distance and speed, or you may not see it at all.

When going up steep slopes, shift to a lower gear so that there is plenty of power to spare rather than overloading the engine.

When applying the brakes, use both the front and rear brakes. Applying only one brake for sudden braking may cause the motorcycle to skid and lose control.

When going down long slopes, control vehicle speed by closing the throttle. Use the front and rear brakes for auxiliary braking.

Riding at the proper rate of speed and avoiding unnecessarily fast acceleration are important not only for safety and low fuel consumption but also for long vehicle life and quieter operation.

When riding in wet conditions or on loose roadway surfaces, the ability to maneuver will be reduced. All of your actions should be smooth under these conditions. Sudden acceleration, braking or turning may cause loss of control.

When the roadway is wet, rely more on the throttle to control vehicle speed and less on the front and rear brakes.

The throttle should also be used judiciously to avoid skidding the rear wheel from too rapid acceleration or deceleration.

On rough roads, exercise caution, slow down, and grip the fuel tank with your knees for better stability.

When quick acceleration is necessary as in passing, shift to a lower gear to obtain the necessary power.

Do not down shift at too high an r.p.m. to avoid damage to the engine from overrevving.

Avoiding unnecessary weaving is important to the safety of both the rider and other motorists.

Do not exceed the legal speed limit or drive too fast for existing conditions. High speed increases the influence of any condition affecting stability and the loss of control.

Operate motorcycle only at moderate speed and out of traffic until you have become thoroughly familiar with its operation and handling characteristics under all conditions. This is a very high performance motorcycle, designed and intended for use by experienced careful riders only!

A new motorcycle must be operated according to a special break-in procedure (see Running in recommendations).



Warning

Before starting engine, check for proper operation of brake, clutch, shifter, throttle controls, correct fuel and oil supply.

Gasoline is extremely flammable and is explosive under certain conditions. Refueled in a well ventilated area with the engine stopped. Do not smoke or allow open flames or sparks when refuelling or servicing the fuel system.

Always close the fuel petcock when the engine is not running to prevent flooding of the throttle body. Do not overfill fuel tank (see instructions page 55).

Motorcycle exhaust contains poisonous carbon monoxide gas. Do not inhale exhaust gases and never run the engine in a closed garage or confined area.

Use only Ducati approved parts and accessories.

This motorcycle was not intended to be equipped with a sidecar or to be used to tow any trailer or other vehicle.

Ducati does not manufacture sidecars or trailers and cannot predict the effects of such accessories on handling or stability, but can only warn that the effects will be adverse and any damage to motorcycle components caused by the use of such accessories will not be remedied under warranty.



Warning

Do not ride the motorcycle with helmets attached to the hook; the helmets could cause an accident by distracting the operator or interfering with normal vehicle operation.

Protective apparel

Always wear a helmet. Most motorcycle accident fatalities are due to head injuries.

For safety eye protection, gloves, and high top, sturdy boots should also be worn.

The exhaust system becomes very hot during operation, never touch the exhaust system. Wear clothing that fully covers your legs. Do not wear loose clothing which could catch on the control levers, footrests, wheels, or chain.

Any amount of alcohol will significantly interfere with your ability to safely operate your motorcycle. Don't drink and ride.

Vehicle identification number (VIN);

Every Ducati motorcycle is identified by two identification numbers (see page 10). fig. A specifically shows the frame identification numbers.

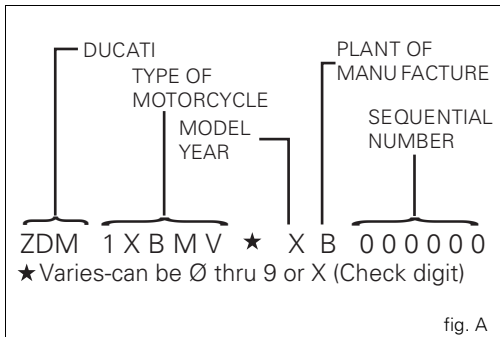

fig. A

Label location (fig. B)

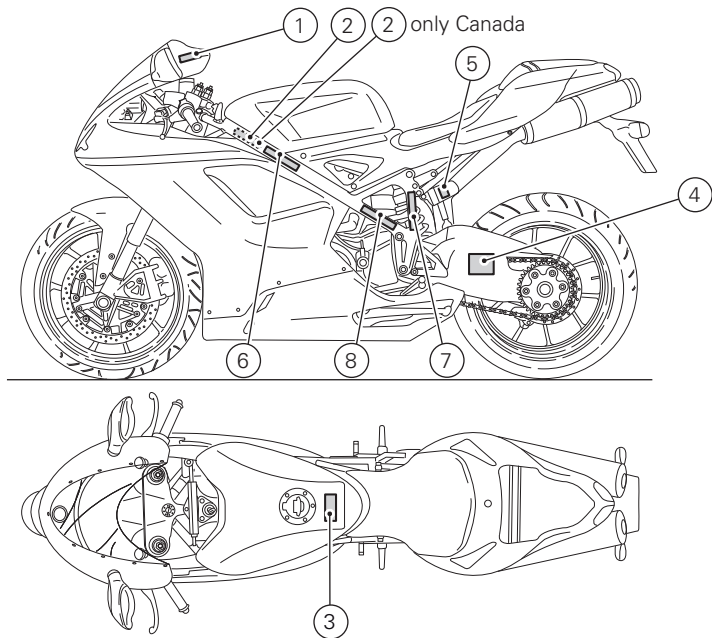

fig. B

WARNING

DO NOT ATTEMPT TO LOOK THROUGH THIS FAIRING. THIS IS NOT A WINDSHIELD, BUT AN AERODYNAMIC FAIRING ONLY. FAILURE TO OBSERVE THIS WARNING COULD RESULT IN A COLLISION OR UPSET AND CONSEQUENT SERIOUS BODILY INJURY. (044-001-001-1)

1

Manufactured by **DUCATI/MOTOFHOLDING spa**DATE:

GVWR: Lbs (kg)
 GAWR front: Lbs (kg) with tire, RIM at PSI cold.
 GAWR rear: Lbs (kg) with tire, RIM at PSI cold.
 This vehicle conforms to all applicable Federal Motor Vehicle Safety standards in effect on the date of manufacture shown above. Type classification: Motorcycle

Vehicle I.D. No.:

044-001-120-11

2

MANUFACTURED BY / FABRIQUÉ PAR: DUCATI/MOTOFHOLDING spa	
TYPE OF VEHICLE / TYPE DE VÉHICULE: MC	DATE: **/****
GVWR / PNBV *** KG.	V.I.N. / N.I.V.: ZDM*****
GAWR / PNBV KG	COLOUR/PL. PRESS. PRESS. / COUL. A FROID PNEUM. SPA
***	***x***
***	***x***

THIS VEHICLE CONFORMS TO ALL APPLICABLE STANDARDS PRESCRIBED UNDER THE CANADIAN MOTOR VEHICLE SAFETY REGULATIONS IN EFFECT ON THE DATE OF MANUFACTURE.
 CE VÉHICULE EST CONFORME À TOUTES LES NORMES QUI LIS SONT APPLICABLES EN VERTU DU RÈGLEMENT SUR LA SÉCURITÉ DES VÉHICULES AUTOMOBILES DU CANADA EN VIGUEUR À LA DATE DE SA FABRICATION. ***x***

2 (Only Canada)

CAUTION

NEVER FILL TANK SO FUEL LEVEL RISES INTO FILLER NECK. IF TANK IS OVERFILLED, HEAT MAY CAUSE FUEL TO EXPAND AND FLOW INTO EVAPORATIVE EMISSION CONTROL SYSTEM RESULTING IN HARD STARTING AND ENGINE HESITATION.

3

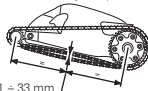
Tensione catena (sul cavalletto laterale)
Chain Tension Adjustment (on side stand)

4

WARNING

CONTAINS HIGHLY COMPRESSED GAS. USE ONLY PERFECTLY DRY NITROGEN GAS, OTHER GASES MAY CAUSE EXPLOSION. DO NOT INCINERATE. REFER TO OWNER'S MANUAL FOR REGULATING GAS.

5

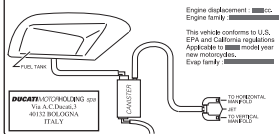
VEHICLE EMISSION CONTROL LABEL

6

VEHICLE EMISSION CONTROL INFORMATION

Engine displacement: cc
 Engine family:
 Engine exhaust control system:

THIS VEHICLE CONFORMS TO U.S. EPA REGULATIONS APPLICABLE TO MODEL YEAR NEW MOTORCYCLES

ENGINE TUNE-UP SPECIFICATIONS

ITEM	SPECIFICATIONS	INSTRUCTIONS
IGNITION TIMING:	<input type="checkbox"/> 6TDC at idle speed	No adjustment
IDLE SPEED (RPM):	<input type="checkbox"/> ± <input type="checkbox"/> mm	No adjustment
IDLE MIXTURE:	Opening <input type="checkbox"/> ± <input type="checkbox"/> mm	No adjustment
VALVE CLEARANCE (in & ex):	Closing <input type="checkbox"/> ± <input type="checkbox"/> mm	See Service Manual
SPARK PLUG: CHAMPION <input type="checkbox"/>	OIL: <input type="checkbox"/>	
SPARK PLUG GAP (mm): <input type="checkbox"/>	FUEL: Unleaded gasoline	

DUCATI/MOTOFHOLDING spa - BOLOGNA - ITALY

7

MOTORCYCLE NOISE EMISSION CONTROL INFORMATION

THIS MOTORCYCLE MEETS EPA NOISE EMISSION REQUIREMENTS OF dBA AT RPM BY THE FEDERAL TEST PROCEDURE. MODIFICATIONS WHICH CAUSE THIS MOTORCYCLE TO EXCEED FEDERAL NOISE STANDARDS ARE PROHIBITED BY FEDERAL LAW. SEE OWNER'S MANUAL. (044-001-120-11)

8

California emission control warranty statement

Your warranty rights and obligations

The California Air Resources Board is pleased to explain the emission control system warranty on your MY 2012 motorcycle. In California, new motor vehicles must be designated, built and equipped to meet the State's stringent anti-smog standards. Ducati North America, Inc. must warrant the emission control system on your motorcycle for the periods of time listed below provided there has been no abuse, neglect or improper maintenance of your motorcycle. Your emission control system may include parts such as fuel-injection system, the ignition system, catalytic converter, and engine computer. Also included may be hoses, belts, connectors and other emission-related assemblies. Where a warrantable condition exists, Ducati North America, Inc. will repair your motorcycle at no cost to you including diagnosis, parts and labor.

Manufacturer's warranty coverage

- 5 years or 30,000 kilometers (18641 miles), whichever first occurs.

Owner's warranty responsibilities:

- As the motorcycle owner, you are responsible for the performance of the required maintenance listed in your owner's manual. Ducati North America, Inc. recommends that you retain all receipts covering maintenance on your motorcycle, but Ducati North America, Inc. cannot deny warranty solely for the lack of receipts or for your failure to ensure the performance of all scheduled maintenance.
- You are responsible for presenting your motorcycle to a Ducati dealer as soon as a problem exists. The warranty repairs should be completed in a reasonable amount of time, not to exceed 30 days.
- As the motorcycle owner, you should also be aware that Ducati North America, Inc. may deny you warranty coverage if your motorcycle or a part has failed due to abuse, neglect, improper maintenance or unapproved modifications.

If you have any questions regarding your warranty rights and responsibilities, you should contact Ducati North America, Inc. at 001.408.253.0499 or the California Air Resource Board at 9528 Telstar Avenue, El Monte, CA 91731.

California evaporation emission system

This system consists of (fig. C):

- 1) Warm air inlet;
- 2) Canister;
- 3) Dell'Orto jet;
- 4) Fuel tank;
- 5) Breather pipe;
- 6) Intake manifolds.

Important

In the event of fuel system malfunction, contact Ducati's authorized Service Centres.

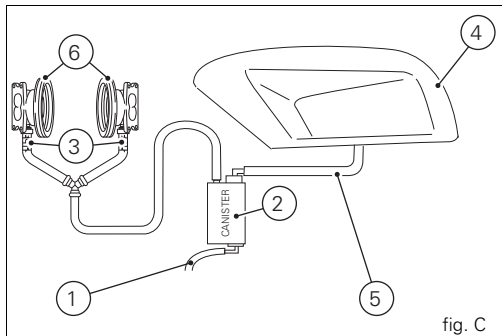

Ducati limited warranty on emission control system

Ducati North America, Inc., 10443 Bandlely Drive Cupertino, California, 95014 warrants that each new 1998 and later Ducati motorcycle, that includes as standard equipment a headlight, tail-light and stoplight, and is street legal:

A) is designed, built and equipped so as to conform at the time of initial retail purchase with all applicable regulations of the United States Environmental Protection Agency, and the California Air Resources Board; and

B) is free from defects in material and workmanship which cause such motorcycle to fail to conform with applicable regulations of the United States Environmental Protection Agency or the California Air Resources Board for a period of use of 30,000 kilometers (18,641 miles) or 5 (five) years from the date of initial retail delivery, whichever first occurs.

I. Coverage

Warranty defects shall be remedied during customary business hours at any authorized Ducati motorcycle dealer located within the United States of America in compliance with the Clean Air Act and applicable regulations of the United States Environmental Protection Agency and the California Air Resources Board. Any part or parts replaced under this warranty shall become the property of Ducati.

In the state of California only, emissions related warranted parts are specifically defined by that state's Emissions Warranty Parts List. These warranted parts are: carburetor and internal parts; intake manifold; fuel tank, fuel injection system; spark advance mechanism; crankcase breather; air cutoff valves; fuel tank cap for evaporative emission controlled vehicles; oil filler cap; pressure control valve; fuel/vapor separator; canister; igniters; breaker governors; ignition coils; ignition wires; ignition points, condensers, and spark plugs if failure occurs prior to the first scheduled replacement, and hoses, clamps, fittings and tubing used directly in these parts. Since emission related parts may vary from model to model, certain models may not contain all of these parts and certain models may contain functionally equivalent parts.

In the state of California only, Emission Control System emergency repairs, as provided for in the California Administrative Code, may be performed by other than an authorized Ducati dealer. An emergency situation occurs when an authorized Ducati dealer is not reasonably available, a part is not available within 30 days, or a repair is not complete within 30 days. Any replacement part can be used in an emergency repair. Ducati will reimburse the owner for the expenses, including diagnosis, not to exceed Ducati's suggested retail price for all warranted parts replaced and labor charges based on Ducati's recommended time allowance for the warranty repair and the geographically appropriate hourly labor rate. The owner may be required to keep receipts and failed parts in order to receive compensation.

II. Limitations

This Emission Control System Warranty shall not cover any of the following:

- A. Repair or replacement required as a result of
 - (1) accident,
 - (2) misuse,
 - (3) repairs improperly performed or replacements improperly installed,
 - (4) use of replacement parts or accessories not conforming to Ducati specifications which adversely affect performance and/or
 - (5) use in competitive racing or related events.
- B. Inspections, replacement of parts and other services and adjustments required for routine maintenance.
- C. Any motorcycle on which odometer mileage has been changed so that actual mileage cannot be readily determined.

III. Limited liability

- A. The liability of Ducati under this Emission Control Systems Warranty is limited solely to the remedying of defects in material or workmanship by an authorized Ducati motorcycle dealer at its place of business during customary business hours. This warranty does not cover inconvenience or loss of use of the motorcycle or transportation of the motorcycle to or from the Ducati dealer. Ducati shall not be liable for any other expenses, loss or damage, whether direct, incidental, consequential or exemplary arising in connection with the sale or use of or inability to use the Ducati motorcycle for any purpose. Some states do not allow the exclusion or limitation

of any incidental or consequential damages, so the above limitations may not apply to you.

B. No express emission control system warranty is given by Ducati except as specifically set forth herein. Any emission control system warranty implied by law, including any warranty of merchantability or fitness for a particular purpose, is limited to the express emission control systems warranty terms stated in this warranty. The foregoing statements of warranty are exclusive and in lieu of all other remedies. Some states do not allow limitations on how long an implied warranty lasts so the above limitation may not apply to you.

C. No dealer is authorized to modify this Ducati Limited Emission Control Systems Warranty.

IV. Legal rights

This warranty gives you specific legal rights, and you may also have other rights which vary from state to state.

V. This warranty is in addition to the Ducati limited motorcycle warranty.

VI. Additional information

Any replacement part that is equivalent in performance and durability may be used in the performance of any maintenance or repairs. However, Ducati is not liable for these parts. The owner is responsible for the performance of all required maintenance. Such maintenance may be performed at a service establishment or by any individual. The warranty period begins on the date the motorcycle is delivered to an ultimate purchaser.

Ducati North America, Inc..
10443 Bandlely Drive
Cupertino, California, 95014
Tel: 001.408.253.0499
Fax: 001.408.253.4099
E-mail: customerservice@ducatiusa.com
Web site: www.ducatiusa.com

Routine maintenance record

KM	MI	DUCATI SERVICE NAME	MILEAGE	DATE
1,000	600			
12,000	7,500			
24,000	15,000			
36,000	22,500			
48,000	30,000			
60,000	37,500			

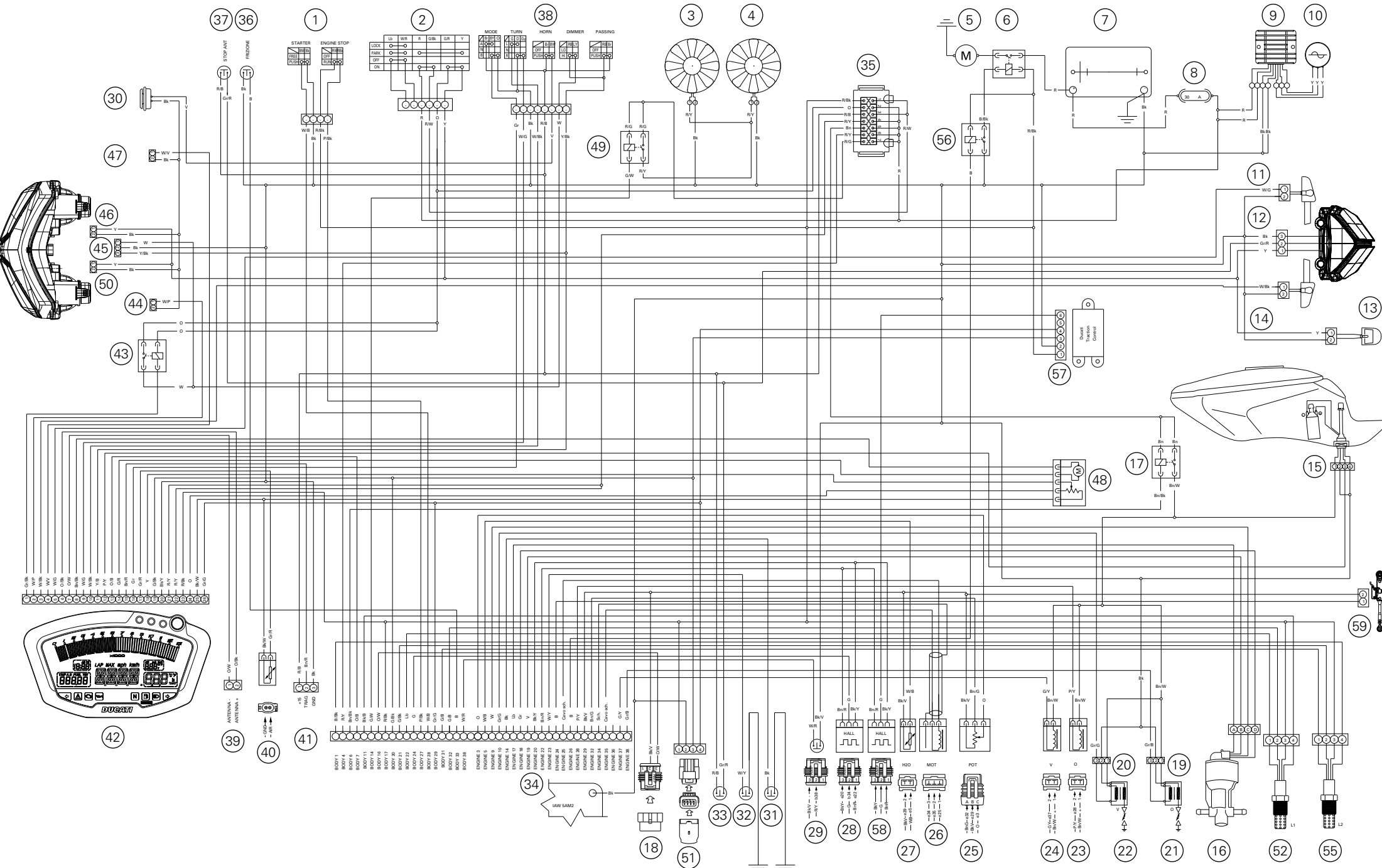

SUPERBIKE 848 Evo Corse Special Edition

Ducati Motor Holding spa
www.ducati.com

Via Cavalieri Ducati, 3
40132 Bologna, Italia
Tel. +39 051 6413111
Fax +39 051 406580

cod 913.7.191.1B