



Superior Clamping and Gripping



Product Information

Gripper for small components MPG-plus 32

MPG-plus

Gripper for small components

Powerful. Fast. Long fingers.

Gripper for small components MPG-plus

2-finger parallel gripper with smooth roller guides of the base jaws

Field of application

Gripping and moving of small to medium-sized workpieces in low contaminated environments, such as assembly, testing, laboratory and pharmaceutical industry

Advantages – Your benefits

Cross roller guidance for precise gripping through due to a scope-free base jaw guidance

Base jaws guided on double roller bearings ensuring low friction and smoothly running

Optimized basic load rating suitable for using long gripper fingers

Drive concept oval piston for maximum gripping forces

Monitoring with electronic magnetic switches for a maximized process reliability

Mounting from two sides in four screw directions for universal and flexible gripper assembly

Air supply via hose-free direct connection or screw connections for flexible pressure supply in all automated systems

Compact dimensions for minimal interfering contours in handling

NEW: food-grade lubrication as a solution for an easy entry into medical technology, lab automation, pharmaceutical and food industry



12520002



Sizes
Quantity: 9



Weight
0.01 .. 0.63 kg



Gripping force
9 .. 370 N



Stroke per jaw
1 .. 10 mm



Workpiece weight
0.05 .. 1.25 kg

Functional description

The oval piston is moved up or down by compressed air. The angled active surfaces of the wedge-hook produce a synchronized, parallel jaw motion.

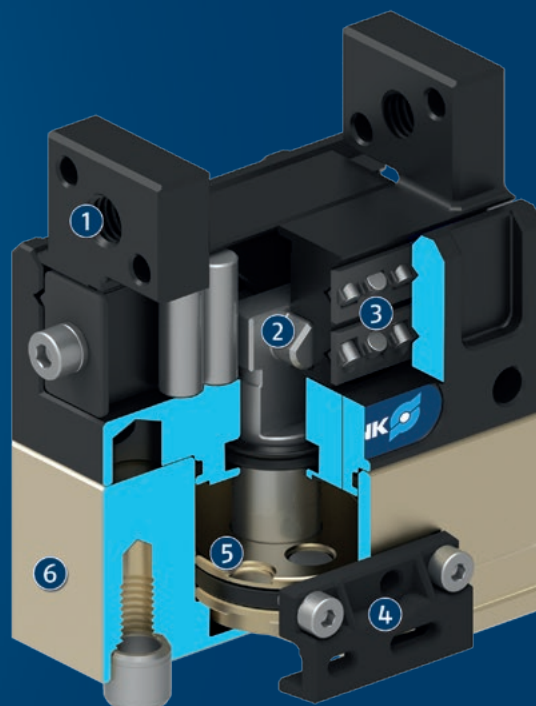

① **Base Jaw**
for the connection of workpiece-specific gripper fingers

② **Wedge-hook design**
for high force transmission and centric gripping

③ **Cross roller guidance**
precise gripping due to backlash-free base jaw guidance

④ **Sensor system**
for monitoring two switching points

⑤ **Oval piston drive**
for power generation

⑥ **Housing**
is weight-optimized due to the use of high-strength aluminum alloy

MPG-plus

Gripper for small components

General notes about the series

Operating principle: Wedge-hook kinematics

Housing material: Aluminum alloy, anodized

Cover housing material: Steel

Base jaw material: Steel

Actuation: pneumatic, with filtered compressed air as per ISO 8573-1:2010 [7:4:4].

Warranty: 24 months

Service life characteristics: on request

Scope of delivery: Centering sleeves, O-rings for direct connection, assembly instructions (operating manual with declaration of incorporation is available online)

Gripping force maintenance device: possible by using the version with mechanical gripping force maintenance or pressure maintenance valve SDV-P

Gripping force: is the arithmetic sum of the individual force applied to each jaw at distance P (see illustration).

Finger length: is measured from the reference surface as the distance P in direction to the main axis.

The maximum permissible finger length applies until the nominal operating pressure is achieved. With higher pressures, the finger length must be reduced proportionally to the nominal operating pressure.

Repeat accuracy: is defined as a distribution of the end Position for 100 consecutive strokes.

Workpiece weight: is calculated for force-fit gripping with a coefficient of static friction of 0.1 and a safety factor of 2 against workpiece slippage at acceleration due to gravity g. For form-fit or capture gripping, there are significantly higher permissible workpiece weights.

Closing and opening times: are purely the times that the base jaws or fingers are in motion. Valve switching times, hose fill times, or PLC reaction times are not included, and are to be considered when cycle times are calculated.

Application example

Pneumatic pick & place unit for small components.

- 1 Pillar assembly system
- 2 Linear module CLM
- 3 2-finger parallel gripper MPG-plus



SCHUNK offers more ...

The following components make the product even more productive – the suitable addition for the highest functionality, flexibility, reliability, and controlled production.



Rotation unit



Linear module



Pick & Place Unit



Manual change system



Attachment valve



Pressure maintenance valve

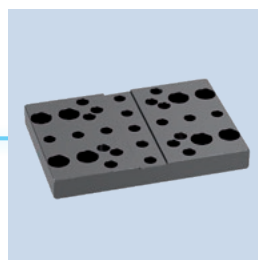

Adapter plate



Finger blank



Flexible position sensor



Magnetic switches



Inductive proximity switches

① For more information on these products can be found on the following product pages or at schunk.com.

Options and special information

Gripping force maintenance version AS/IS: The mechanical gripping force maintenance version ensures minimum gripping force even in the event of a pressure drop. In the AS/S version this acts as a closing force, in the IS version as an opening force.

Optional adapter plates: allows frontal mounting of the gripper

Precision version P: for the highest accuracy

Version FPS for flexible position sensor: This version is prepared for the use with the flexible position sensor FPS, and allows monitoring of several gripping positions.

protective cover version HUE: Fully protects the gripper against external influences

Food-grade lubrication: The requirements of EN 1672-2:2020 are not fully met.

MPG-plus 32

Gripper for small components



Gripping force O.D. gripping

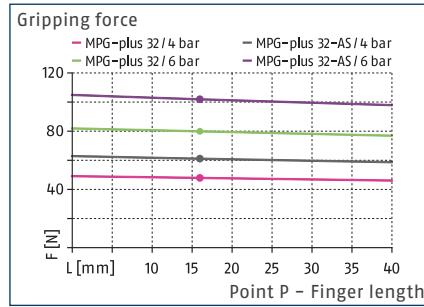

Gripping force I.D. gripping

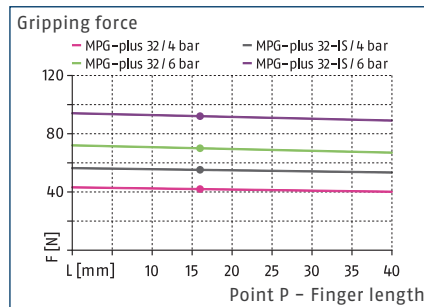

Dimensions and maximum loads

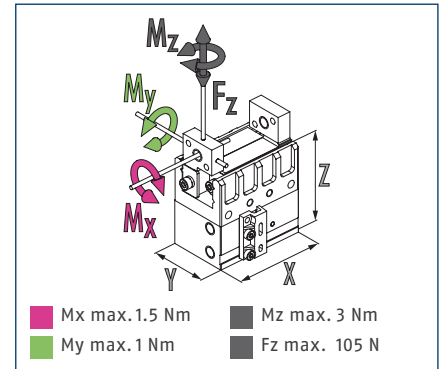

① The indicated moments and forces are static values, apply for each base jaw and may appear simultaneously. Loads may additionally occur to the moment produced by the gripping force itself.

Technical data

Description		MPG-plus 32	MPG-plus 32-AS	MPG-plus 32-IS	MPG-plus 32-FPS
ID		0305511	0305512	0305513	0305514
Stroke per jaw	[mm]	4	4	4	4
Closing/opening force	[N]	80/70	105/-	-/90	80/70
Min. spring force	[N]		25	20	
Weight	[kg]	0.1	0.13	0.13	0.13
Recommended workpiece weight	[kg]	0.43	0.43	0.43	0.43
Fluid consumption double stroke	[cm ³]	1.7	4.1	3.5	1.7
Min./nom./max. operating pressure	[bar]	2/6/8	4/6/6.5	4/6/6.5	2/6/8
Closing/opening time	[s]	0.02/0.02	0.03/0.04	0.04/0.03	0.02/0.02
Closing/opening time with spring	[s]		0.20	0.20	
Max. permissible finger length	[mm]	40	40	40	40
Max. permissible weight per finger	[kg]	0.04	0.04	0.04	0.04
IP protection class		30	30	30	30
Min./max. ambient temperature	[°C]	5/90	5/90	5/90	5/90
Repeat accuracy	[mm]	0.02	0.02	0.02	0.02
Cleanroom class ISO 14644-1:2015		6	6	6	6
Dimensions X x Y x Z	[mm]	32 x 22 x 34	32 x 22 x 47.3	32 x 22 x 47.3	32 x 22 x 44.8
Options and their characteristics					
High-temperature version		39305511	39305512	39305513	39305514
Min./max. ambient temperature	[°C]	5/100	5/100	5/100	5/100
Precision version		0305516	0305518	0305519	
protective cover version HUE		1460630	1460632	1460634	
Weight	[kg]	0.16	0.19	0.19	
IP protection class		54	54	54	
Max. permissible weight per finger	[kg]	0.02	0.02	0.02	
Dimensions X x Y x Z	[mm]	55 x 34.8 x 49	55 x 34.8 x 62.3	55 x 34.8 x 62.3	

Main view

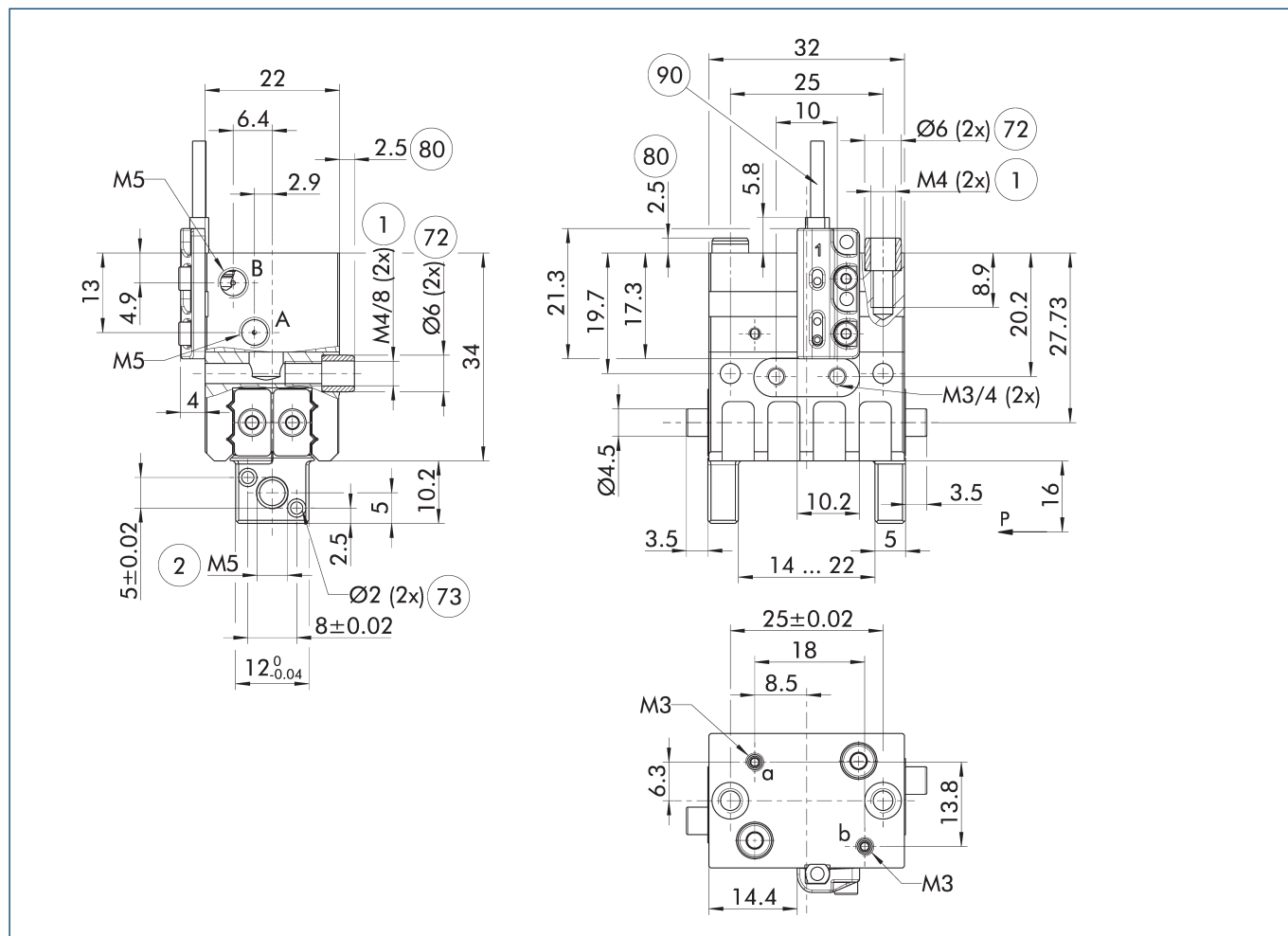

The drawing shows the basic version of the gripper with open jaws, without dimensional consideration of the options described below.

① The SDV-P pressure maintenance valve can also be used for I.D. or O.D. gripping alternatively or in addition to the spring-loaded, mechanical gripping force maintenance device (see catalog section on accessories).

- A, a Main / direct connection, gripper opening
- B, b Main / direct connection, gripper closing
- ① Gripper connection
- ② Finger connection

- ⑦② Fit for centering sleeves
- ⑦③ Fit for centering pins
- ⑧① Depth of the centering sleeve hole in the counter part
- ⑨① MMS 22...-PI2-... sensor

Maximum permitted finger projection

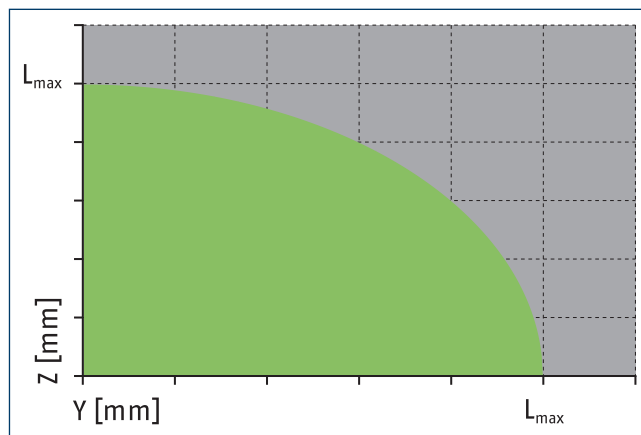
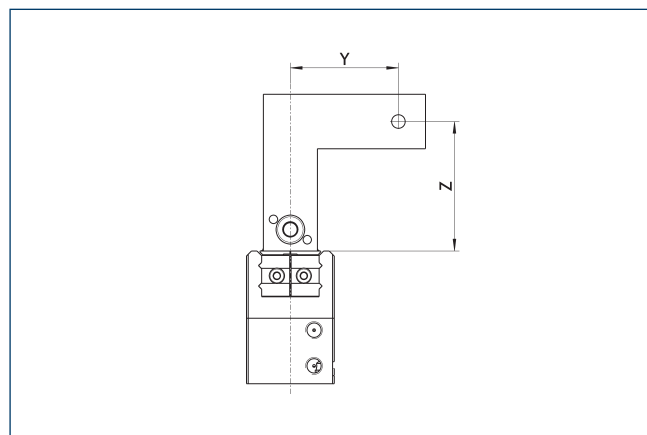

■ Permitted range ■ Inadmissible range
 L_{max} is equivalent to the maximum permitted finger length, see the technical data table.

MPG-plus 32

Gripper for small components

Hose-free direct connection M3

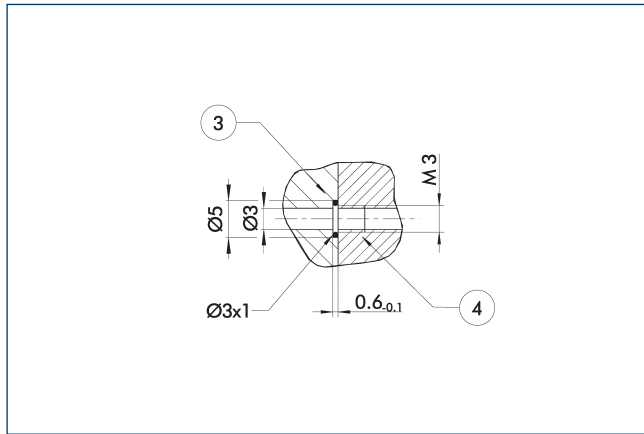

③ Adapter ④ Grippers

The direct connection is used for supplying compressed air without hoses. Instead, the pressure medium is fed through bore-holes in the mounting plate.

Gripping force maintenance AS

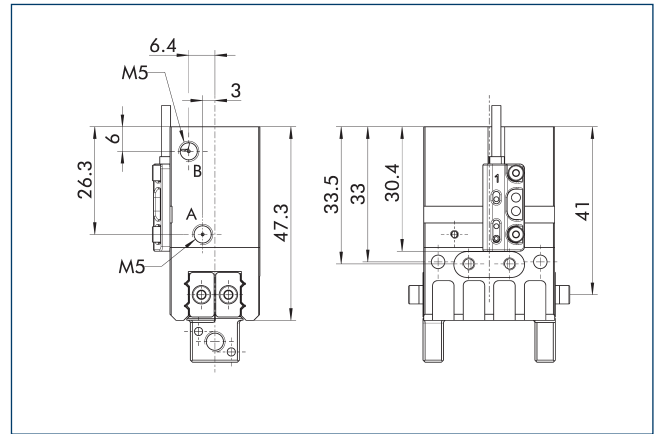

The mechanical gripping force maintenance device ensures that a minimum clamping force will be applied even if there is a drop in pressure. This acts as closing force in the AS / S version, and as opening force in the IS version. Besides this, the gripping force maintenance device can be used to increase the gripping force or for single actuated gripping.

Gripping force maintenance IS

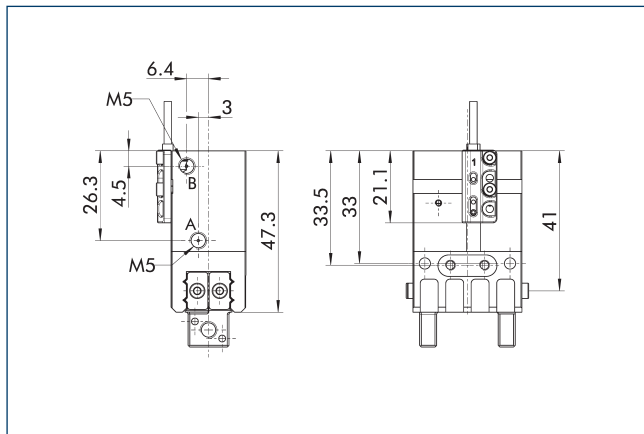

The mechanical gripping force maintenance device ensures that a minimum clamping force will be applied even if there is a drop in pressure. This acts as closing force in the AS / S version, and as opening force in the IS version. Besides this, the gripping force maintenance device can be used to increase the gripping force or for single actuated gripping.

Jaw design

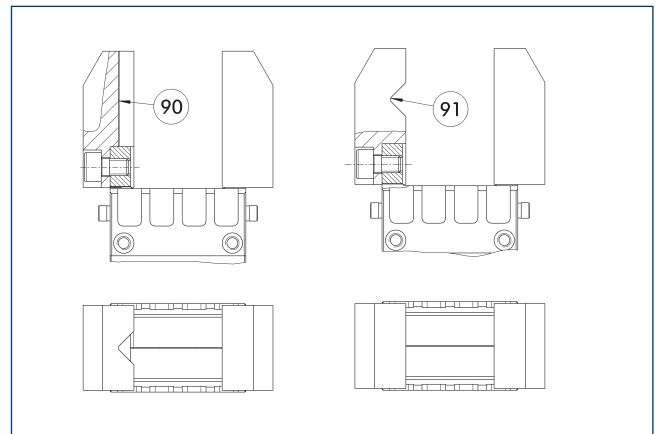

⑨⑩ Vertically positioned prism ⑨⑪ Horizontally positioned prism

A workpiece, which is gripped using three points of contact, can be reliably gripped with high repeatability. A system with more than three points of contact is overdetermined. The drawing shows two alternative gripper finger designs for coaxial and radial gripping of a cylindrical part.

Precision version

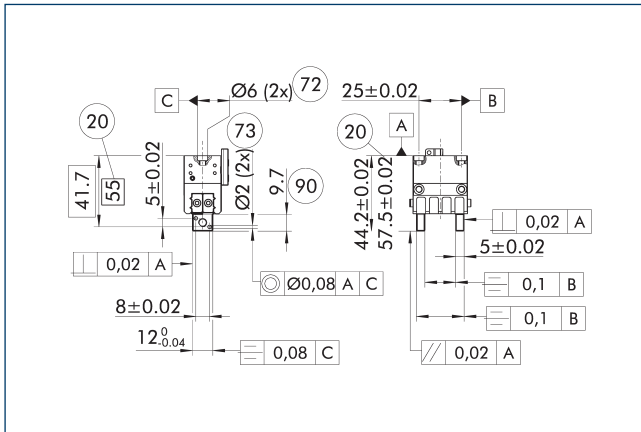

- ②0 For AS / IS version
- ⑦2 Fit for centering sleeves
- ⑦3 Fit for centering pins
- ⑨0 Length of the usable finger surface

The indicated tolerances just refer to the variants of precision versions shown in the chart of technical specifications. All other variants of precision versions are available on request.

Protection cover HUE

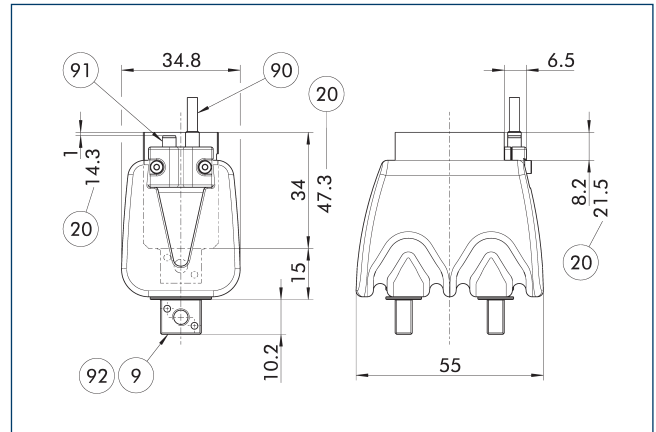

- ⑨ For mounting screw connection diagram, see basic version
- ②0 For AS / IS version
- ⑨0 Sensor IN ...
- ⑨1 Cylindrical pins
- ⑨2 Intermediate jaw (stainless steel)

The HUE protection cover fully protects the gripper against external influences. The assembly diagram shifts by the height of the intermediate jaw. The finger length is still measured from the upper edge of the gripper housing. The protection cover is a wear part and can be ordered separately as a spare part.

- ④ Two sensors are required per unit for monitoring two positions. Only sensors from the IN 40 series can be used. The gripper is prepared for this, and no additional mounting kit is required. Monitoring with magnetic sensors is not possible. The bracket for magnetic sensors is not included in the scope of delivery. If the gripper is used without a sensor, the two cylindrical pins (item 91) must not be removed so that the IP protection class of the product remains guaranteed.

Flexible position sensor

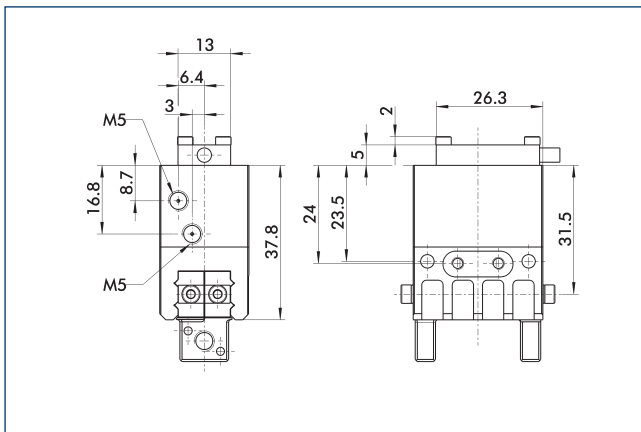

The following FPS position sensor can differentiate between five programmable areas or switching points for the stroke of a gripper, and can be used in connection with a PC as a measuring system.

Adapter plate

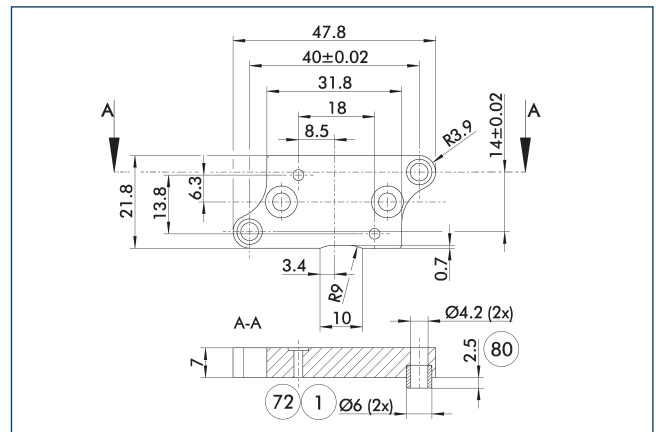

- ① Gripper connection
- ⑦2 Fit for centering sleeves
- ⑧0 Depth of the centering sleeve hole in the counter part

The adapter plate includes an O-ring* for a direct air connection, additional centering sleeves, and screws for mounting the gripper.
*Optional only with pneumatic actuators

Description	ID
Adapter plate	
APL-MPG-plus 32	0305517

- ④ The adapter plate is a separately ordered, optional accessory.

MPG-plus 32

Gripper for small components

Adapter plate

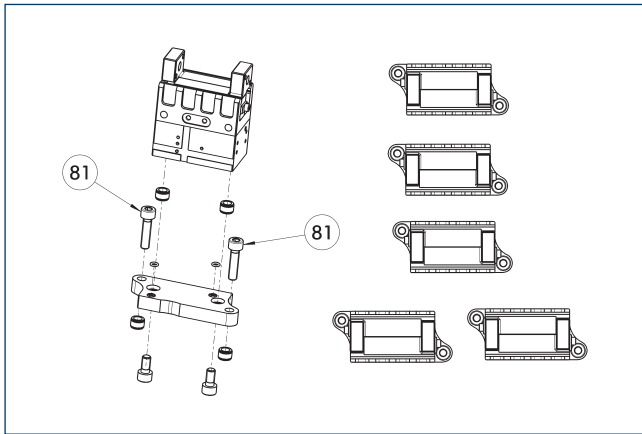

⑧① Not included in the scope of delivery

The adapter plate includes an 0-ring* for a direct air connection, additional centering sleeves, and screws for mounting the gripper.*Optional only with pneumatic actuators

Description	ID	
Adapter plate		
APL-MPG-plus 32	0305517	

① The adapter plate is a separately ordered, optional accessory.

SDV-P pressure maintenance valve

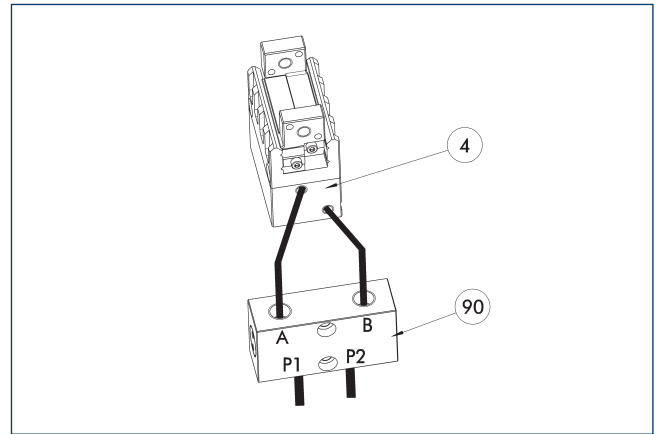

④ Grippers

⑨⑩ SDV-P pressure maintenance valve

The SDV-P pressure maintenance valve ensures in emergency STOP situations that the pressure in the piston chamber of pneumatic gripper, swivel, linear, and quick-change modules is temporarily maintained.

Description	ID	Recommended hose diameter
		[mm]
Pressure maintenance valve		
SDV-P 04	0403130	6
Pressure maintenance valve with air bleed screw		
SDV-P 04-E	0300120	6

① In order to achieve the specified closing and opening time for each gripper variant, the recommended hose diameter must be used. The direct allocation of the respective variant of the gripper for the respective SDV-P can be found at schunk.com.

Finger blanks with BSWs ABR-BSWS-MPG-plus 32

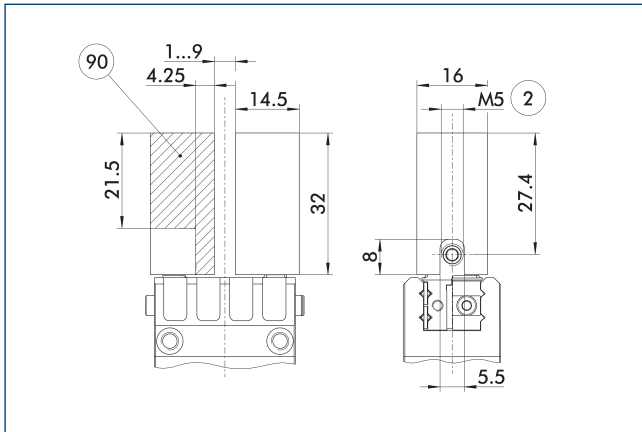

② Finger connection

⑨⑩ Machining volume

Finger blanks for customized subsequent machining with integrated jaw quick-change system for precise and fast finger changes.

Description	ID	Scope of delivery
Finger blank with jaw quick-change system		
ABR-BSWS-MPG-plus 32	0302895	2

Finger blanks with BSWs

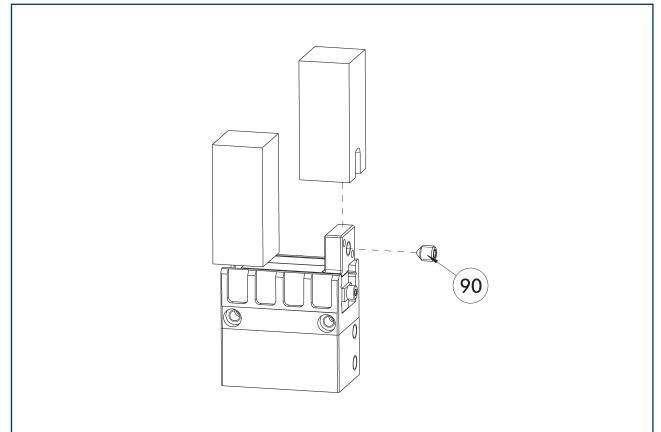

⑨⑩ Included in the jaw quick-change system's scope of delivery

The finger blanks with jaw quick-change system allow fast and manual gripper finger changes. The mechanical interface to the gripper is already integrated. Only the specific workpiece geometry needs to be machined into the finger blank.

Description	ID	Scope of delivery
Finger blank with jaw quick-change system		
ABR-BSWS-MPG-plus 32	0302895	2

Finger blanks ABR-MPG-plus 32

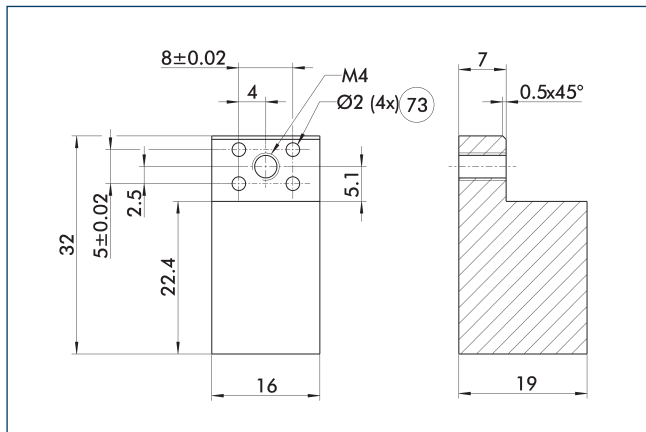

73 Fit for centering pins

The drawing shows the finger blank which can be reworked by the customer.

Description	ID	Material	Scope of delivery
Finger blank			
ABR-MPG-plus 32	0340212	Aluminum (3.4365)	2

Attachment valves

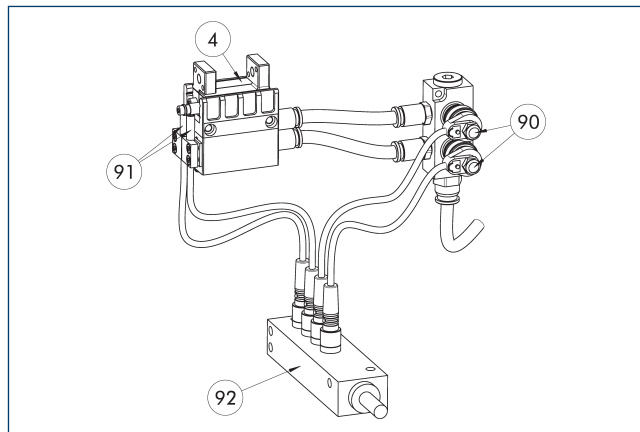

- 4 Grippers
- 90 Micro valves
- 91 Sensor
- 92 Sensor distributor
- 93 Y distributor

The set of attachment valves reduces the compressed air consumption as there is no need to ventilate or bleed the supply lines. This can also reduce cycle time. The hose-free direct assembly of the micro valves reduces the hosing effort for the gripper. To further simplify electrical connection of the valves and sensors, their signals can be bundled via an optional distributor.

Description	ID	Often combined
Add-on valve set		
ABV-MV15-S2-M5	0303375	
ABV-MV15-S2-M5-V2-M8	0303376	
ABV-MV15-S2-M5-V4-M8	0303377	●
ABV-MV15-S2-M5-V8-M8	0303378	

① A set of add-on valves ABV is required per actuator. The ABV set contains two 3/2 micro valves, a valve base, pneumatic screw connections, and optionally a sensor distributor with two, four or eight inputs or outputs. Sensors for monitoring the gripper need to be ordered separately. Pneumatic hoses are not included in the scope of delivery.

Modular Assembly Automation

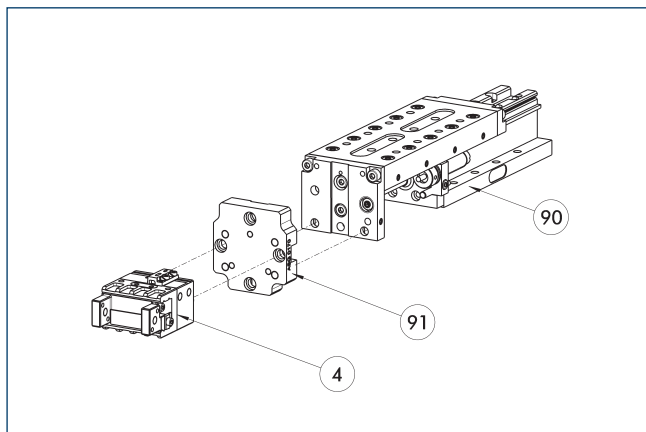

- 4 Grippers
- 90 CLM/KLM/LM/ELP/ELM/ELS/HLM linear modules
- 91 ASG adapter plate

Grippers and linear modules can be combined with standard adapter plates from the modular assembly system. For more information see our main catalog "Modular Assembly Automation".

Attachment kit for proximity switch IN 40

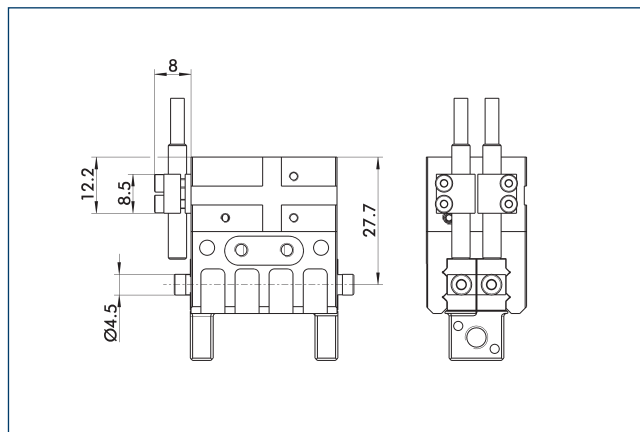

The attachment kit includes a bracket, switch cams, and mounting screws. Proximity switches have to be ordered separately.

Description	ID	
Attachment kit for proximity switch		
AS-IN40-MPG-plus 32	0305515	

① This attachment kit needs to be ordered optionally as an accessory.

MPG-plus 32

Gripper for small components

IN 40 inductive proximity switches

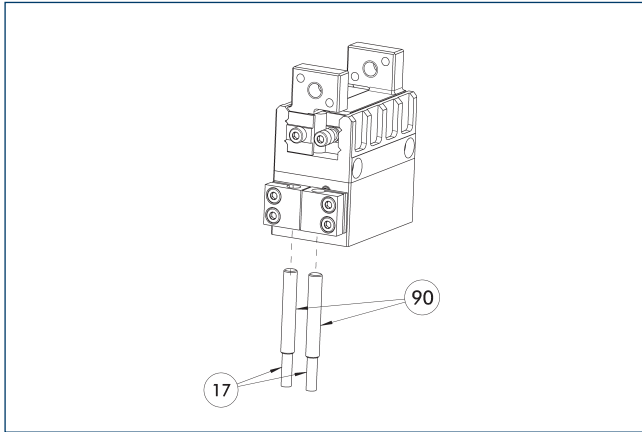

⑰ Cable outlet

⑨⑩ Sensor IN ...

End position monitoring can be mounted with an attachment kit.

Description	ID	Often combined
Attachment kit for proximity switch		
AS-IN40-MPG-plus 32	0305515	
Inductive proximity switches		
IN 40-S-M12	0301574	
IN 40-S-M8	0301474	●
INK 40-S	0301555	

① Two sensors (closer/S) are required for each unit and extension cables are available as an option. This attachment kit needs to be ordered optionally as an accessory. For sensor cables, note the minimum permissible bending radii. These are generally 35 mm.

Attachment kit for proximity switch IN 5

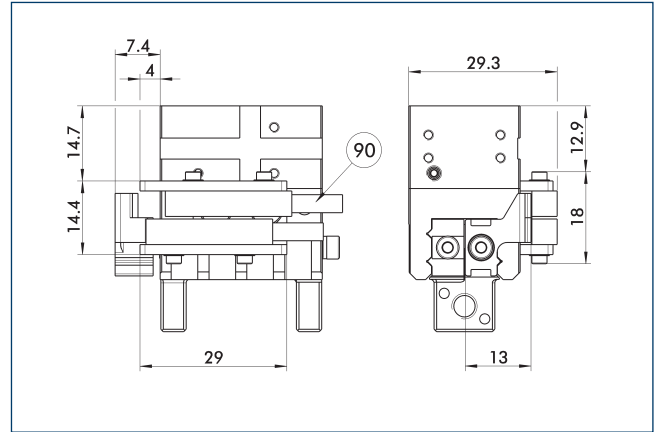

⑨⑩ Sensor IN ...

The attachment kit includes a bracket, switch cams, and mounting screws. Proximity switches have to be ordered separately.

Description	ID	
Attachment kit for proximity switch		
AS-IN5-MPG-plus 32	0340151	

① This attachment kit needs to be ordered optionally as an accessory.

IN 5 inductive proximity switches

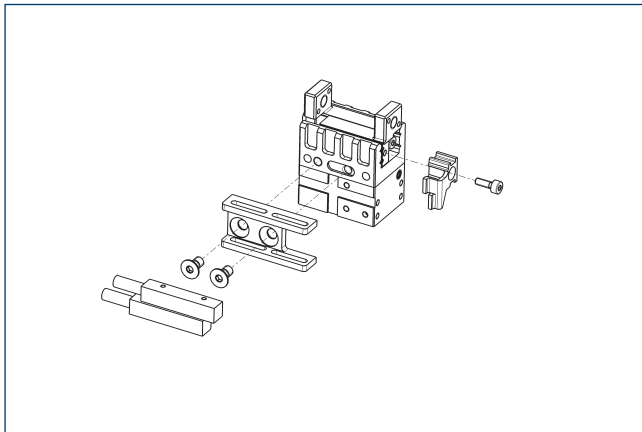

End position monitoring can be mounted with an attachment kit.

Description	ID	Often combined
Attachment kit for proximity switch		
AS-IN5-MPG-plus 32	0340151	
Inductive proximity switches		
IN 5-S-M12	0301569	
IN 5-S-M8	0301469	●
INK 5-S	0301501	●

① Two sensors (closer/S) are required for each unit and extension cables are available as an option. This attachment kit needs to be ordered optionally as an accessory. For sensor cables, note the minimum permissible bending radii. These are generally 35 mm.

Flexible position sensor

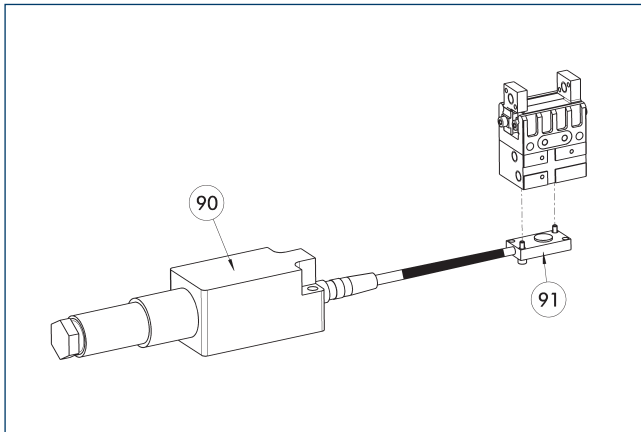

90 FPS-F5 evaluation electronic 91 FPS-S sensor

The FPS monitoring is only possible for this size in combination with the appropriate FPS variant of the gripper.

Description	ID	Often combined
Sensor		
FPS-S 13	0301705	
Evaluation electronics		
FPS-F5	0301805	●
Cable extension		
KV BG08-SG08 3P-0050	0301598	
KV BG08-SG08 3P-0100	0301599	
Connection cables		
KA BG16-L 12P-1000	0301801	
clip for plug/socket		
CLI-M8	0301463	

① When using an FPS system, an FPS sensor (FPS-S) as well as an electronic processor (FPS-F5 / F5 T) are required for each gripper as well as a mounting kit (AS), if listed. Cable extensions (KV) are optionally available – see catalog chapter "Accessories."

Monitoring for stacked arrangements

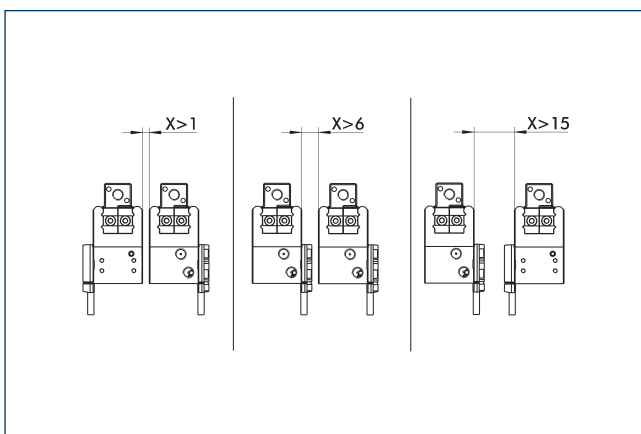

CAUTION: Monitoring is carried out by magnetic switches, and in case of side-by-side assembly of several units, a minimum distance of X mm between the units must be maintained.

MPG-plus 32

Gripper for small components

Programmable magnetic switch MMS 22-PI2

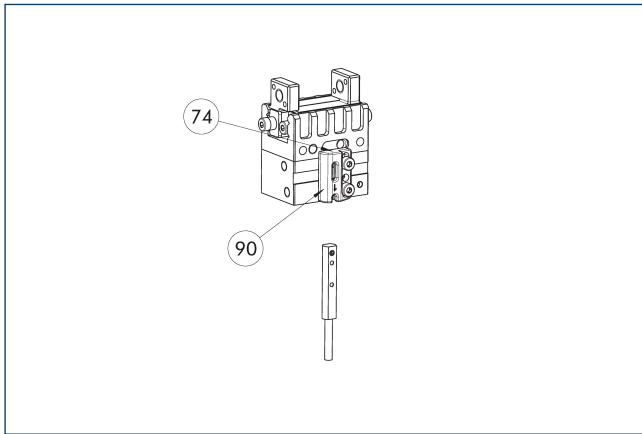

74 Limit stop for sensor

90 Vertical attachment of the bracket

Position monitoring with two programmable positions per sensor and electronics built into the sensor. Can be programmed using MT magnetic teaching tool (included in the scope of delivery) or ST plug teaching tool (optional). End position monitoring for mounting in the C-slot. If the ST plug teaching tools are listed in the table provided, teaching is only possible with the ST teaching tools.

Description	ID	Often combined
Programmable magnetic switch		
MMS 22-PI2-S-M8-PNP	0301180	●
MMSK 22-PI2-S-PNP	0301182	
Programmable magnetic switch with lateral cable outlet		
MMS 22-PI2-S-M8-PNP-SA	0301186	
MMSK 22-PI2-S-PNP-SA	0301188	
Programmable magnetic switch with stainless steel housing		
MMS 22-PI2-S-M8-PNP-HD	0301130	
MMSK 22-PI2-S-PNP-HD	0301132	

- ① One sensor is required per unit for monitoring two positions. Extension cables and sensor distributors are optionally available. Additional product variants of the sensor, and further information and technical data can be found in the catalog chapter sensor systems.

MMS-P programmable magnetic switch

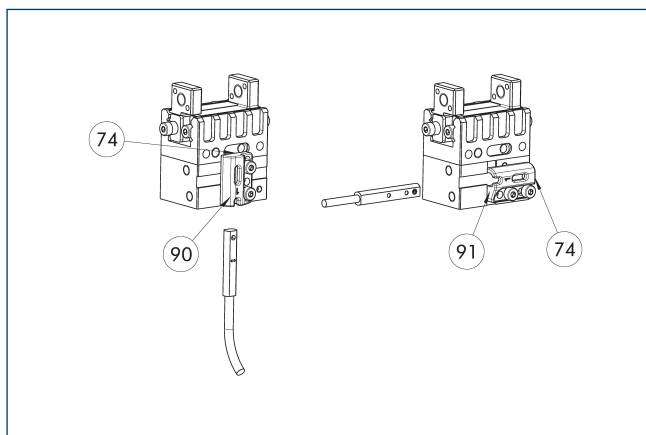

- ⑦④ Limit stop for sensor
- ⑨① Horizontal attachment of the bracket
- ⑨① Vertical attachment of the bracket

Position monitoring with two programmable positions per sensor. End position monitoring for mounting in the C-slot.

Description	ID	Often combined
Programmable magnetic switch		
MMSK-P 22-S-PNP	0301371	
MMS-P 22-S-M8-PNP	0301370	●
Connection cables		
KA GLN0804-LK-00500-A	0307767	●
KA GLN0804-LK-01000-A	0307768	
KA WLN0804-LK-00500-A	0307765	
KA WLN0804-LK-01000-A	0307766	
clip for plug/socket		
CLI-M8	0301463	
Sensor distributor		
V2-M8-4P-2XM8-3P	0301380	

- ① The bracket (90) is delivered vertically mounted. To use the magnetic sensor in a horizontal orientation, the bracket can be horizontally assembled (91). The mounting bracket has an internal stop for the MMS-P (74).

Analog position sensor MMS-A

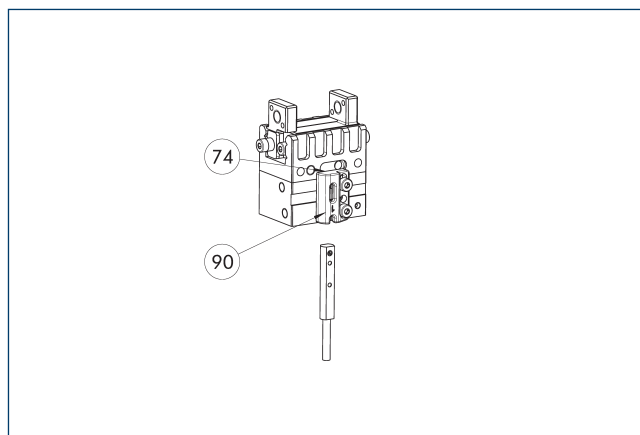

- ⑦④ Limit stop for sensor
- ⑨① Vertical attachment of the bracket

No-contact measuring, analog multi-position monitoring for any number of positions.

Description	ID	
Analog position sensor		
MMS 22-A-10V-M08	0315825	
MMS 22-A-10V-M12	0315828	

- ① One sensor is required for each gripper. No additional mounting kit is required – the gripper is equipped for use of the sensor by default. Further information and technical data can be found in the catalog chapter sensor systems.

MPG-plus 32

Gripper for small components

Flexible position sensor with MMS-A

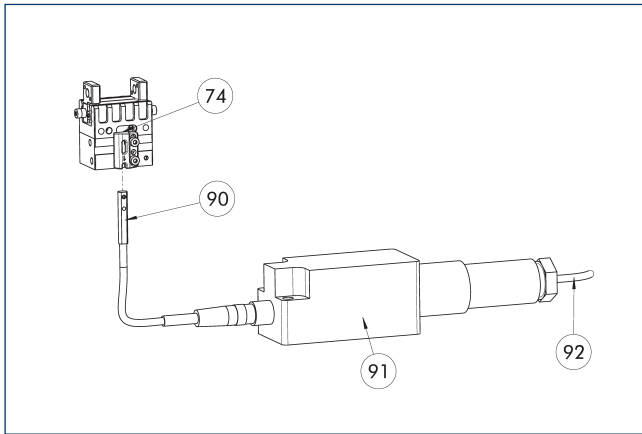

- ⑦④ Limit stop for sensor
- ⑨① FPS-F5 evaluation electronic
- ⑨① MMS 22-A-... sensor
- ⑨② Connection cables

Flexible position monitoring of up to five positions.

Description	ID	
Analog position sensor		
MMS 22-A-05V-M08	0315805	
Evaluation electronics		
FPS-F5	0301805	
Connection cables		
KA BG16-L 12P-1000	0301801	

- ① When using an FPS system, one MMS 22-A-05V and one electronic processor (FPS-F5) are required per each gripper, as well as a mounting kit (AS), if listed. Cable extensions (KV) are optionally available – see catalog chapter "Accessories."

Programmable magnetic switch MMS-I0-Link

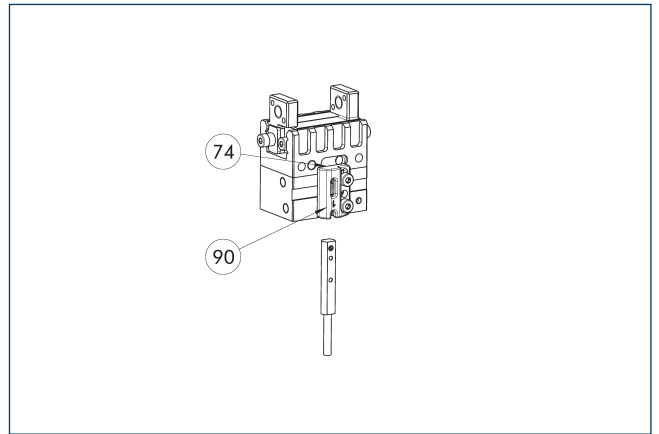

- ⑦④ Limit stop for sensor
- ⑨① Vertical attachment of the bracket

Sensor for multi-position monitoring through detection of the complete gripper stroke. The sensor is mounted directly in the C-slot of the gripper. Sensor programming on the gripper takes place via the I0-Link interface or the MT magnetic teach tool (included in scope of delivery). An I0-Link master is required for operation.

Description	ID	
Programmable magnetic switch		
MMS 22-I0L-M08	0315830	
MMS 22-I0L-M12	0315835	

- ① One sensor is required for each gripper. No additional mounting kit is required – the gripper is equipped for use of the sensor by default. Further information and technical data can be found in the catalog chapter sensor systems.



SCHUNK GmbH & Co. KG
Spann- und Greiftechnik

Bahnhofstr. 106 - 134
D-74348 Lauffen/Neckar
Tel. +49-7133-103-0
Fax +49-7133-103-2399
info@de.schunk.com
schunk.com

Folgen Sie uns | *Follow us*

