

Installation and Maintenance

Tool changers TC5 and TC20

M0119-1

Tool changers | Swivels | Swivels Tool changers | Grippers | Hose packages | Valve Units | Tool systems



The information in this document is subject to change without prior notice and should not be regarded as an undertaking from Robot System Products AB. Robot System Products AB assumes no responsibility for errors that may occur in this document.

Robot System Products AB bears no responsibility for damage that is incurred by the use of this document, or the software or hardware described in this document.

The document, or parts of it, may not be reproduced or copied without prior permission from Robot System Products AB. It may neither be imparted to a third party, nor otherwise be used without authorization. Infringement hereof will be subject to action in accordance with the applicable laws.

Further copies of this document can be obtained from Robot System Products AB at current prices.

© Robot System Products AB

Robot Systems Products AB
Isolatorvägen 4
SE-721 37 Västerås
Sweden

CONTENTS

1 INTRODUCTION	5
1.1 Installation and Maintenance manual.....	5
1.2 Safety.....	6
1.2.1 General	6
1.2.2 Explanation of warnings.....	6
1.3 Tightening torques	7
1.4 Recommended equipment.....	7
1.5 Required products.....	7
2 INSTALLATION.....	8
2.1 Installation of tool changer on robot.....	8
2.2 Installation of tool attachment on tool.....	9
2.3 Programming.....	10
3 MAINTENANCE AND SERVICE.....	11
3.1 Maintenance scheme	11
3.1.1 Every second week	11
3.1.2 Every six-months or 250,000 tool changes.....	11
3.1.3 To replace when damaged or worn-out	11
3.2 Specification of maintenance activities	12
3.2.1 Visual inspection of tool changer	12
3.2.2 Visual inspection and cleaning of tool attachment	13
3.2.3 Cleaning and lubrication of tool changer.....	13
3.2.4 Cleaning and lubrication of tool attachment.....	14
4 DISMOUNTING AND REPLACEMENT	15
4.1 Replacement of tool changer	15
4.2 Replacement of tool attachment	16
4.3 Replacement of wear parts	17
4.3.1 Replacement of air sealings.....	17
4.3.2 Replacement of signal pins (electric versions only)	17
5 DISPOSAL AND RECYCLING.....	18

1 INTRODUCTION

Robot System Products is a front-rank provider of peripheral products for high performance robot applications. We provide complete tool systems solutions for your robot installations, aiming to improve your productivity with the most reliable and cost-effective tooling on the market. Continuously we explore emerging technologies, working with leading edge design.

Robot System Products has a wide range of standard robot peripheral products:

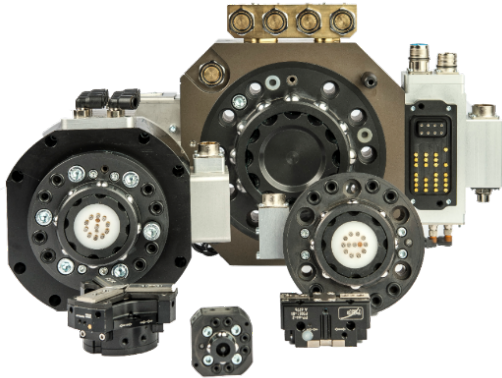

- Tool changers
- Swivels
- Swivel tool changers
- CiRo
- Grippers
- Hose Packages
- Valve units
- Tool systems
- Tool parking systems

Robot System Products' tool changers are constructed to maximize the flexibility and reliability of your robot fleet. Through our patented locking device TrueConnect™ robustness and high safety are combined with low weight and compactness. With our swivels compressed air, water, electrical and data signals as well as weld and servo power are transferred to your tools with robot motion capabilities fully maintained. Our Swivel tool changers unite the TrueConnect™ mechanism with our swivel technology, combining the best out of the two technologies. With RSPs unique Circular Rotators cables and hoses can be freely selected with high robot flexibility maintained, and the space requirements reduced. Our integrated Tool systems are delivered as complete plug-and-play solutions designed for quick and simple installation.

Robot System Products' product lines are available for all major robot brands and come with complete documentation. 3D-models for simulation are available for download at:

www.rsp.eu.com

1.1 Installation and Maintenance manual

This document describes how the tool changers, TC5 and TC20, including corresponding tool attachments and options for transfer of signals and air, are installed and replaced. In addition, the document describes required maintenance activities, including inspection, cleaning, lubrication, replacement of wear parts, required tools and products and disposal and recycling.

The *Technical Descriptions* of each respective unit are separate documents containing product information, drawings, technical data, electrical and pneumatic diagrams and lists of spare parts.

1.2 Safety

1.2.1 General

The integrator installing the tool changer into the system must follow the safety demands stated in standards and provisions applicable in the country where the tool changer system is to be installed. The products are all prepared for CE-certification.

The user of the Robot System Products' tool changer is responsible that law and directives applicable in respective countries, with regards to safety, are followed. The user is also responsible to guarantee that all safety devices are installed correctly.



WARNING!

Never carry out service work on a robot that has not been taken out of operation. See safety information for the robot.



WARNING!

Only perform work on tools attached to the tool changer if the air pressure is safely switched off.



WARNING!

Be aware that tool changer and tool attachment may cause personal injury and equipment damage if dropped.



NOTE!

The tool changer shall always be in locked position, also when empty, to avoid unexpected locking if air pressure is lost.



WARNING!

Electric signals must be disconnected/switched off when docking the tool attachment. This is to prevent sparking between signal pins and tool attachment.

1.2.2 Explanation of warnings

The warnings in this document are specific to the products in this manual. It is expected that the user also pay attention to certain notifications from the robot manufacturer and/or the manufacturers of other components used in the installation.



WARNING!

The warning sign will make you aware that a situation could result in potential serious injury or damage to equipment.



NOTE!

The note sign will alert you about something important to consider.

1.3 Tightening torques

Tightening torques for mounting (screw class 8.8)

Dimension	Torque
M4	3 Nm
M5	6 Nm
M6	10 Nm
M8	24 Nm
M10	47 Nm
M12	82 Nm
M16	200 Nm

1.4 Recommended equipment

Equipment recommended for installation and maintenance work

Tools	Applications
Complete set of Allen keys	For all socket head cap screws
Torque wrench	For dismounting and mounting
Torx keys	For dismounting and mounting
Pair of pliers	For dismounting the signal pins
Screw driver	For removing the air sealings

1.5 Required products

Product	Specification	Note
Grease, 3HXG1000-413	Magnalube-G, Teflon grease	Air sealings.
Grease I0876	Molykote BR2Plus	For locking balls.
Cleaning agent	Industrial alcohol or similar	For cleaning of tool changer and tool attachment.
Glue	Loctite 480 (or similar)	For gluing the air sealings.
Cloth	Lint free cloth	For cleaning.



NOTE! Chemical resistance protective gloves are recommended when using grease or cleaning agents such as industrial alcohol. Safety goggles are recommended when working with cleaning agents such as industrial alcohol. Adequate ventilation should be provided when chemical substances are used.

2 INSTALLATION

2.1 Installation of tool changer on robot

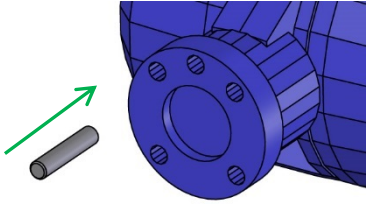
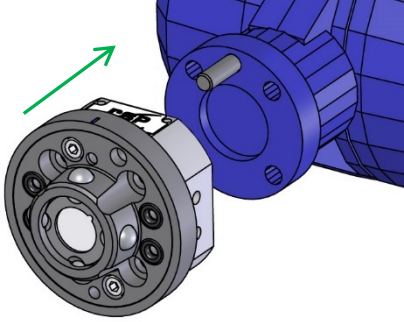
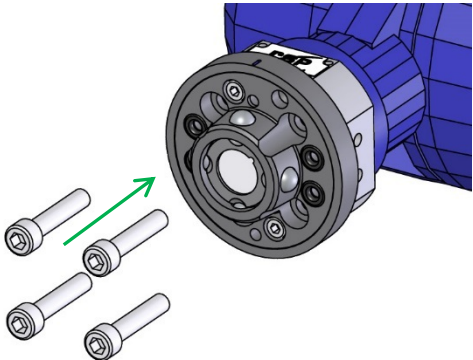

	Action	Note
1	Safety	Read the safety section 1.2 .
2	Service position	Place the robot in service position.
3	Power off	Switch the power off and lock the circuit breaker. NOTE! Read the safety chapter for the robot.
4	Mount guide pin 	Press the enclosed guide pin into the robot flange. <i>Alternatively, if adaptation plate is used:</i> Mount the adaptation plate on the robot flange (see tightening torques above). Press the enclosed guide pin into the adaptation plate.
5	Fit tool changer 	Lift the tool changer to the robot flange (or adaptation plate). The arrow on the front of the tool changer indicates the position of the hole for the guide pin. Make sure that the guide pin is fitted to the guide hole in the tool changer. WARNING! The tool changer may cause personal injury and equipment damage if dropped.
6	Mount tool changer 	Mount the tool changer with the enclosed screws. Use an Allen key for tightening (see tightening torques above).
7	Connect air hoses	Connect the air hoses according to markings. <i>Pneumatic diagrams</i> are found in the <i>Technical Description</i> of respective unit.
8	Connect electrical signals (electrical versions only)	Connect electrical connectors in accordance with selected unit. <i>Circuit diagrams</i> are found in the <i>Technical Description</i> of respective unit.
9	Power on	Unlock the circuit breaker and switch the power on.

2.2 Installation of tool attachment on tool

	Action	Note
1	Safety	Read the safety section 1.2 .
2	Mount guide pins	Press guide pins, as applicable, into the corresponding holes on the tool.
3	Fit tool attachment	Fit the tool attachment and tool to each other using the guide pins. WARNING! The tool attachment may cause personal injury and equipment damage if dropped.
4	Mount tool attachment	Mount the tool attachment using a torque wrench. See tightening torques above. NOTE! Fastening screws can be entered either from the tool attachment side or the tool side. Screws are specified in the <i>Technical Description</i> of respective tool attachment.

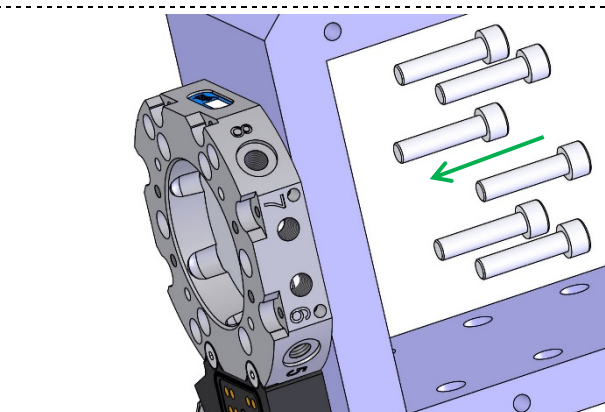
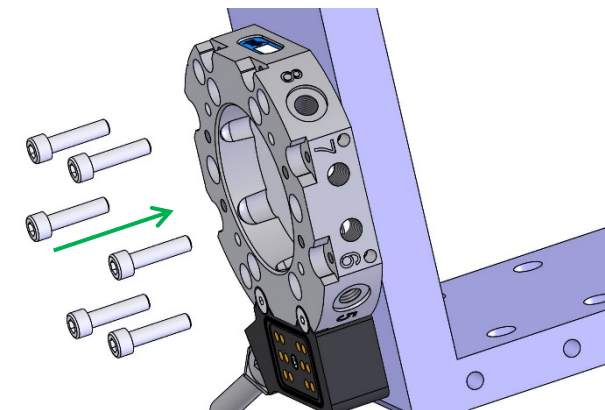
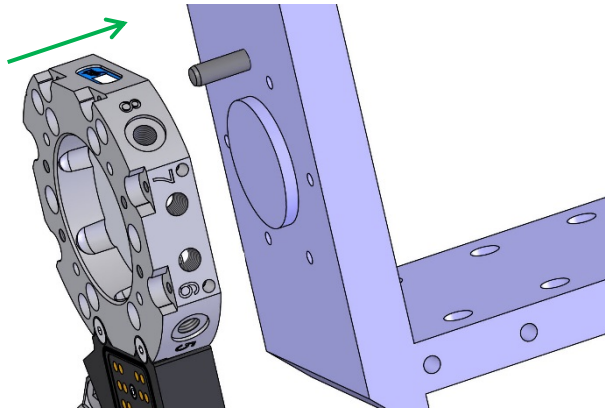

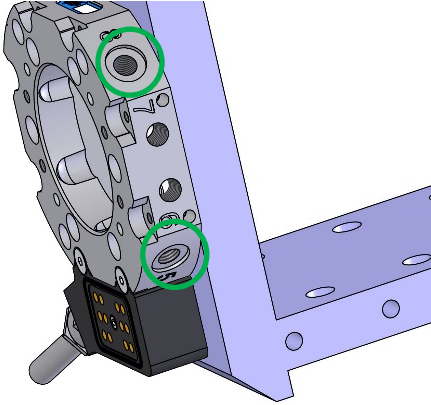
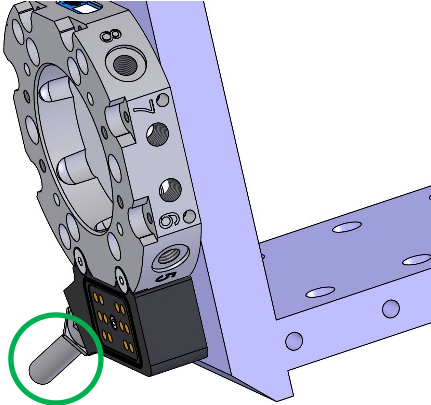
5	<p>Connect air hoses</p> 	<p>Connect air hoses to the tool attachment.</p> <p>Pneumatic diagrams are found in the <i>Technical Description</i> of respective unit.</p>
6	<p>Connect signals (electrical versions only)</p> 	<p>Connect electrical connectors in accordance with selected unit.</p> <p>Circuit diagrams are found in the <i>Technical Description</i> of respective unit.</p>

2.3 Programming

The following will ensure a correct docking position.

	Action
1	Attach a spare tool attachment to the tool changer.
2	Position the spare tool attachment above the tool attachment that is mounted at the tool.
3	The correct position is found when the tool attachments are parallel, centered and the engraved arrows are on the same line.
4	Save the position. The robot can move to this position with high speed.
5	Dismount the spare tool attachment.
6	Go back to the saved position and move the tool changer (in axis 6 direction) the remaining distance to the tool attachment (mounted at the tool).
7	Save the position. The robot should move the final distance to this position with low speed.

3 MAINTENANCE AND SERVICE

The tool changers and the tool attachments must be maintained regularly to ensure proper function. The specified intervals are approximate and valid under normal conditions, corresponding to 2 tool changes per minute during 2 work shifts per working day, i.e. 42.000 tool changes per month. Under extreme conditions, such as dirty environments or extreme robot movements, the intervals should be shortened. Consider the table as a guide and update as your production experience of each system increases.



NOTE

Read the safety [section 1.2](#) before any maintenance activities are carried out.



NOTE!

Tool changers must only be dismantled and repaired by Robot System Products during the warranty period. Otherwise the warranty will not be valid.

3.1 Maintenance scheme

3.1.1 Every second week

The following maintenance activities should be carried out every second week.

Activity	Equipment		Description
Inspection	Tool changer	General	Visual inspection (section 3.2.1).
		Locking balls	Check locking balls (section 3.2.1).
		Air sealings	Check air sealings (section 3.2.1).
		Spring-loaded pins	Check spring-loaded signal (section 3.2.1).
	Tool attachment	General	Visual inspection of tool attachment and cables (section 3.2.2).
Cleaning	Tool attachment	Signal contacts	Clean contact surfaces (section 3.2.2).

3.1.2 Every six-months or 250,000 tool changes

The following maintenance activities should be carried out every six-months or 250,000 tool changes, whichever comes first.

Activity	Equipment		Description
Cleaning and lubrication	Tool changer	Locking balls	Clean locking balls and add new lubrication (section 3.2.3).
		Air sealings	Clean air sealings (section 3.2.3).
		Spring-loaded pins	Clean spring-loaded signal pins (section 3.2.3).
	Tool attachment	Locking cavities	Clean the cavities of the locking balls (section 3.2.4).
		Contact surfaces	Clean the contact surfaces of air sealings (section 3.2.4).

3.1.3 To replace when damaged or worn-out

Equipment		Description
Tool changer	Air sealings	See section 4.3.1 .
	Spring-loaded signal pins	See section 4.3.2 .

3.2 Specification of maintenance activities

3.2.1 Visual inspection of tool changer

The following maintenance activities should be carried out on the TC every 2nd week.



Action	Note
<p>Check locking balls</p> 	<p>Check each ball to make sure it moves freely. For cleaning and lubrication of balls see section 3.2.3.</p> <p>NOTE! If balls get stuck there is a risk that the tool attachment jams.</p> <p>WARNING! Risk of getting squeezed between piston and ball holder when the piston is taking closed position</p>
<p>Check air sealings</p> 	<p>Check that the air sealings are clean. For cleaning see section 3.2.3.</p> <p>Check that the air sealings are not damaged. For making replacements see section 4.3.1.</p>
<p>Check spring-loaded signal pins (electrical versions only)</p> 	<p>Check that the spring-loaded signal pins are clean. For cleaning see section 3.2.3.</p> <p>Check that the spring-loaded signal pins are not worn-out or damaged. For making replacements see section 4.3.2.</p>
<p>Check cables and hoses</p>	<p>Check for damages and squeezing, replace if damaged.</p>
<p>Check rotation stops</p>	<p>Check that rotation stops are not worn-out or damaged, replace if damaged.</p>
<p>Check tool changer in general</p>	<p>Check tool changer for damages. For replacement see section 4.1.</p>

3.2.2 Visual inspection and cleaning of tool attachment

The following maintenance activities should be carried out on the TA every 2nd week.

Action	Note
Clean contact surface (electrical versions only) 	Wipe the contact surface with a lint free cloth.
Check cables and hoses	Check cables and hoses for damages and squeezing, replace if damaged.
Check tool attachment in general	Check the tool attachment for damages. For replacement see section 4.2 .

3.2.3 Cleaning and lubrication of tool changer

The following maintenance activities should be carried out on the TC every 6th month or after 250,000 tool changes, whichever comes first.

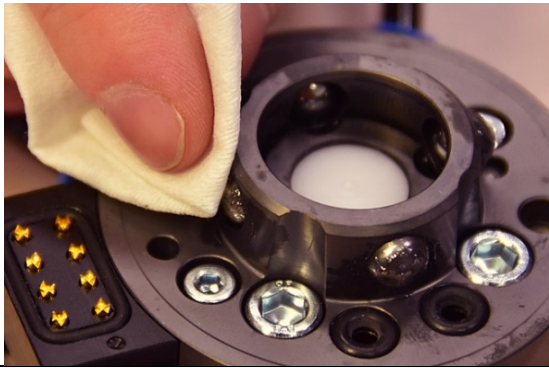
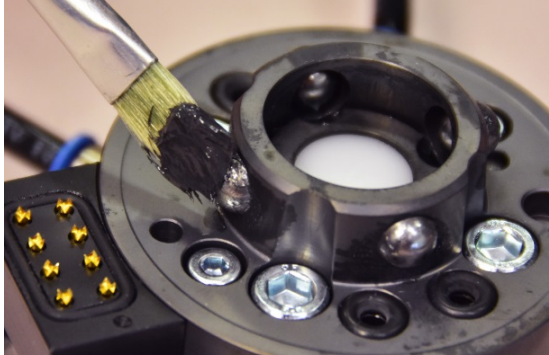

Action	Note
Clean locking balls 	Check the locking balls and wipe them clean with a lint free cloth. WARNING! Risk of getting squeezed between piston and ball holder when the piston is taking closed position
Lubricate locking balls 	Apply a small amount of grease (Molykote BR2Plus) on the locking balls. NOTE! It is important that this is done or else there is a risk that the tool attachment jams.



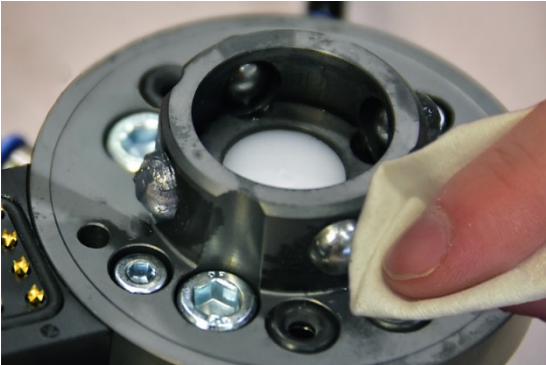
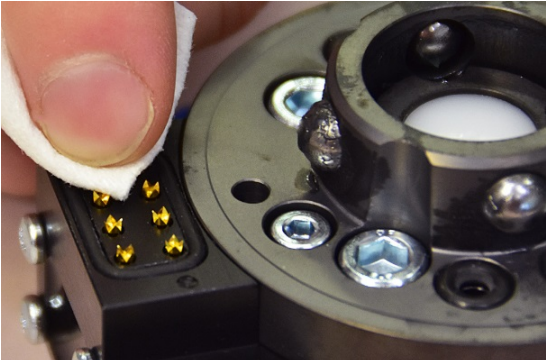

<p>Clean air sealings</p> 	<p>Wipe air sealings clean with a lint free cloth.</p>
<p>Clean spring-loaded signal pins</p> 	<p>Clean the contact surfaces of the spring-loaded signal pins with a nylon brush.</p> <p>NOTE! Signal pins shall be cleaned whenever blackened.</p>



3.2.4 Cleaning and lubrication of tool attachment

The following maintenance activities should be carried out on the TA every 6th month or after 250,000 tool changes, whichever comes first.

Action	Note
<p>Clean locking cavities</p> 	<p>Clean the cavities of the locking balls with a lint free cloth.</p> <p>NOTE! It is important that this is done or else there is a risk that the tool attachment jams.</p>
<p>Clean contact surfaces of air sealings</p> 	<p>Wipe the contact surfaces of the air sealings clean with a lint free cloth.</p>



4 DISMOUNTING AND REPLACEMENT

4.1 Replacement of tool changer



	Action	Note
1	Safety	Read the safety section 1.2 .
2	Dismount tool	Leave tool, with tool attachment mounted, in tool stand.
3	Service position	Place the robot in service position. NOTE! The tool change function shall be in locked position.
4	Power off	Switch the power off and lock the circuit breaker. NOTE! Read the safety chapter for the robot.
5	Pneumatic air off	NOTE! The pressure in the pneumatic system must be released before dismounting begins.
6	Dismount hoses	Dismount the air hoses from the tool changer. NOTE! Make sure that no dirt enters the air hoses.
7	Release electrical connectors	NOTE! Handle the contact with care, as it is sensitive to mechanical damage. Make sure that no dirt enters the contacts.
8	Remove screws	Remove the screws holding the tool changer to the robot flange. WARNING! The tool changer may cause personal injury and equipment damage if dropped. NOTE! Be careful not to damage the signal pins.
9	Dismount tool changer	NOTE! A guide pin is mounted between the tool changer and the robot flange.
10	Clean robot flange	Clean the robot flange/adaptation plate using a lint free cloth.
11	Mount replacement tool changer	Follow instructions in section 2.1 .

4.2 Replacement of tool attachment

	Action	Note
1	Safety	Read the safety section 1.2 .
2	Undock tool	Undock tool attachment, with tool mounted, in a safe and fully supported position for dismounting.
3	Release electrical connections	Disconnect electric power and signals. NOTE! Handle contacts with care, as they are sensitive to mechanical damage. Make sure that no dirt enters the contacts.
4	Dismount hoses	Dismount the air hoses from the tool attachment. NOTE! Make sure that no dirt enters the air hoses.
5	Remove screws	Remove the screws holding the tool attachment to the tool. WARNING! The tool attachment is heavy and may cause personal injury and equipment damage if dropped.
6	Dismount tool attachment	NOTE! A guide pin is mounted between the tool attachment and the tool.
7	Clean the flange at the tool	Clean flange at the tool using a lint free cloth.
8	Mount tool attachment	Follow instructions in section 2.2 .

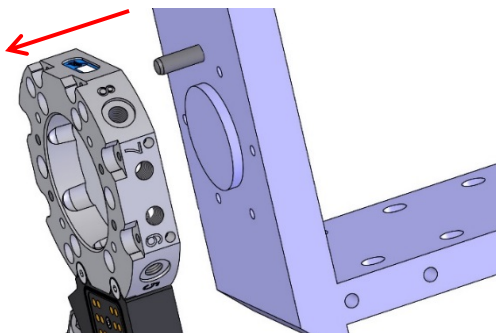
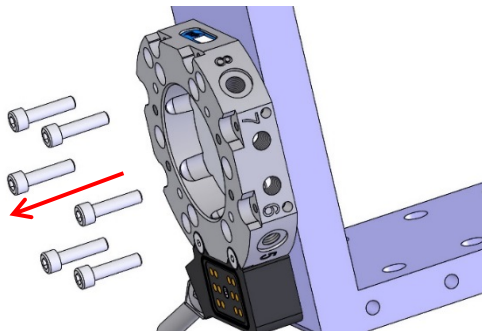
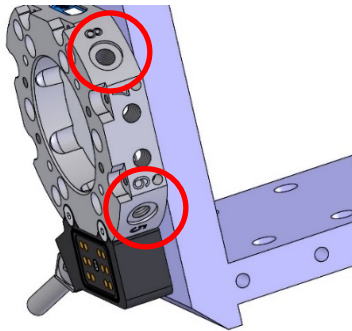
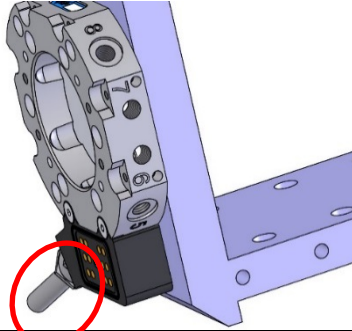

4.3 Replacement of wear parts

4.3.1 Replacement of air sealings

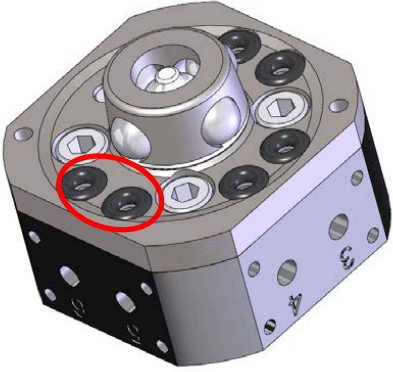

	Action	Note
1	Remove air sealings 	Remove the air sealings with a screw driver. NOTE! There are totally 6 air sealings.
2	Clean sealing holes	Wipe clean the sealing holes. Remove all remaining parts of sealing and glue.
3	Replace air sealing	Glue the new air sealing in the sealing groove. Use a small amount of Loctite 480 (or similar). Press the sealing 60-120 seconds until the glue hardens.

4.3.2 Replacement of signal pins (electric versions only)

Replace a signal pin when worn or damaged.

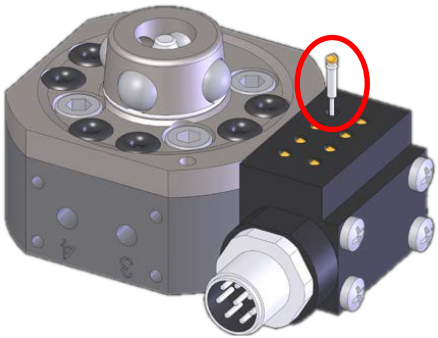

	Action	Note
1	Power off	Switch the power off and lock the circuit breaker.
2	Remove signal pins 	Pull out the signal pins with a pair of pliers. NOTE! There are totally 8 signal pins.
3	Replace signal pins	Fit the new signal pins by pushing them into the sleeves. NOTE! The signal pins should be fully pressed into the sleeve using a small screwdriver.
4	Power on	Unlock the circuit breaker and switch the power on.



5 DISPOSAL AND RECYCLING

Taking care of spent equipment

Used equipment must be taken care of in an environmentally-friendly way.

When disposed of, a major share of the material, or its energy content, can be recycled. The quantities possible to recycle vary depending on technical resources and practises in respective country. Non-recyclable components shall be handed over to an authorized environmental waste treatment facility for destruction or disposal.

Electronics

Electronic equipment shall be sent to an authorized recycling company or sorted into different component materials and treated as such.

Metals

Metals can, in general, be melted down, recycled and used in new products. They shall be sorted according to type and surface coating and handed over to an authorized recycling facility.

Metal components of steel and aluminium are substantial in size and easy to identify. Copper is primarily used in transmission of power for spot welding. Silver or gold plating of contact surfaces may occur.

Plastics

Thermoplastics can, in general, be re-heated and recycled without any major loss of quality. They shall be handed over to an authorized recycling facility. POM occurs in swivel housings, etc. PTFE in some sealings.

Rubber

Rubber shall be handed over to an authorized environmental waste treatment facility either for recycling, disposal or destruction. Rubber occurs in O-rings.

Other material

All other material shall be sorted and handed to an authorized environmental waste treatment facility in accordance with national legislation.

