

Assembly and Operating Manual

EMH

Electric permanent magnetic gripper



Superior Clamping and Gripping



Imprint

Copyright:

This manual is protected by copyright. The author is SCHUNK GmbH & Co. KG. All rights reserved.

Technical changes:

We reserve the right to make alterations for the purpose of technical improvement.

Document number: 1393220

Version: 04.00 | 01/12/2022 | en

Dear Customer,

Thank you for trusting our products and our family-owned company, the leading technology supplier of robots and production machines.

Our team is always available to answer any questions on this product and other solutions. Ask us questions and challenge us. We will find a solution!

Best regards,

Your SCHUNK team

Customer Management

Tel. +49-7133-103-2503

Fax +49-7133-103-2189

cmg@de.schunk.com



Please read the operating manual in full and keep it close to the product.

Table of Contents

1	General.....	5
1.1	About this manual.....	5
1.1.1	Presentation of Warning Labels.....	5
1.1.2	Definition of Terms.....	5
1.1.3	Applicable documents.....	6
1.1.4	Variants.....	6
1.1.5	Sizes.....	6
1.2	Warranty.....	6
1.3	Scope of delivery.....	6
1.4	Accessories.....	6
2	Basic safety notes	7
2.1	Intended use.....	7
2.2	Constructional changes.....	7
2.3	Spare parts.....	7
2.4	Ambient conditions and operating conditions.....	7
2.5	Personnel qualification.....	8
2.6	Personal protective equipment.....	8
2.7	Notes on safe operation.....	9
2.8	Transport.....	9
2.9	Malfunctions.....	9
2.10	Disposal.....	10
2.11	Fundamental dangers.....	10
2.11.1	Protection during handling and assembly.....	10
2.11.2	Protection during commissioning and operation.....	11
2.11.3	Protection against dangerous movements.....	11
2.11.4	Protection against electric shock.....	11
2.11.5	Protection against magnetic and electromagnetic fields.....	12
3	Technical data.....	13
3.1	Type key.....	13
3.2	Name plate.....	13
3.3	Basic Data.....	14
3.3.1	Variant EMH-RP.....	14
3.3.2	Variant EMH-MP.....	15
3.3.3	Variant EMH-DP.....	15
4	Design and description.....	17
4.1	Design.....	17
4.1.1	Variant EMH-RP.....	17
4.1.2	Variant EMH-MP.....	18

4.1.3	Variant EMH-DP	19
4.2	Description	20
4.3	Magnetic suitability of the workpiece material	21
4.4	Factors influencing the holding force	21
5	Assembly	23
5.1	Installing and connecting	23
5.2	Mechanical connection	23
5.3	Electrical connection	24
5.3.1	Power connection pin allocation	25
5.3.2	Logic connection pin allocation	26
5.4	Installing the pole extension (optional)	26
6	Commissioning	28
6.1	Adjusting the holding force	29
6.2	Signal sequence "Product magnetization"	29
6.3	Signal sequence "Product ready for operation"	30
7	Troubleshooting	32
7.1	Product remains inoperable even after the power supply is turned on	32
7.2	LED Ready does not light up	32
7.3	LED Error flashes	32
7.4	Workpiece is detached from the product	33
7.5	Demagnetization was not performed correctly	33
8	Maintenance	34
8.1	Maintenance intervals	34
8.2	Check and repair the product	34
9	EU Declaration of Conformity	35
10	Translation of the original declaration of incorporation	36
11	UKCA declaration of Conformity	37
12	UKCA declaration of incorporation	38
13	Annex to declaration of Incorporation	39

1 General

1.1 About this manual

This manual contains important information for a safe and appropriate use of the product.

This manual is an integral part of the product and must be kept accessible for the personnel at all times.

Before starting work, the personnel must have read and understood this operating manual. Prerequisite for safe working is the observance of all safety instructions in this manual.

Illustrations in this manual are provided for basic understanding and may differ from the actual product design.

In addition to these instructions, the documents listed under ▶ 1.1.3 [□ 6] are applicable.

1.1.1 Presentation of Warning Labels

To make risks clear, the following signal words and symbols are used for safety notes.



⚠ DANGER

Danger for persons!

Non-observance will inevitably cause irreversible injury or death.



⚠ WARNING

Dangers for persons!

Non-observance can lead to irreversible injury and even death.



⚠ CAUTION

Dangers for persons!

Non-observance can cause minor injuries.

NOTICE

Material damage!

Information about avoiding material damage.

1.1.2 Definition of Terms

The term "product" replaces the product name on the title page in this manual.

1.1.3 Applicable documents

- General terms of business *
- Catalog data sheet of the purchased product *

The documents labeled with an asterisk (*) can be downloaded from [schunk.com](https://www.schunk.com).

1.1.4 Variants

This operating manual applies to the following variations:

- EMH-RP Round pole
- EMH-MP Multipole
- EMH-DP Dual pole

1.1.5 Sizes

This operating manual applies to the following sizes:

- EMH-RP 036-B
- EMH-RP 045-B
- EMH-RP 084-B
- EMH-RP 114-B
- EMH-MP 060-B
- EMH-DP 080-B

1.2 Warranty

If the product is used as intended, the warranty is valid for 24 months from the ex-works delivery date under the following conditions:

- Observance of the applicable documents
- Observance of the ambient conditions and operating conditions

Parts touching the workpiece and wear parts are not included in the warranty.

1.3 Scope of delivery

The scope of delivery includes

- Electric permanent magnetic gripper EMH in the version ordered
- Assembly and Operating Manual
- Accessory pack: 2 centering sleeves

1.4 Accessories

The following accessories, which must be ordered separately, are required for the product:

- Power cable
- Control cable
- Pole extension

2 Basic safety notes

2.1 Intended use

The product is designed exclusively for gripping and temporarily holding workpieces or objects.

- The product may only be used within the scope of its technical data, ▶ 3 [□ 13].
- The product is intended for installation in a machine/automated system. The applicable guidelines for the machine/automated system must be observed and complied with.
- The product is intended for industrial and industry-oriented use. Its use outside enclosed spaces is only permitted if suitable protective measures are taken against outdoor exposure. The product is not suitable for use in salty air.
- The product can be used within the permissible load limits and technical data for holding workpieces during simple machining operations, but is not a clamping device according to EN 1550:1997+A1:2008.
- Appropriate use of the product includes compliance with all instructions in this manual.
- Any utilization that exceeds or differs from the appropriate use is regarded as misuse.

2.2 Constructional changes

Implementation of structural changes

By conversions, changes, and reworking, e.g. additional threads, holes, or safety devices can impair the functioning or safety of the product or damage it.

- Structural changes should only be made with the written approval of SCHUNK.

2.3 Spare parts

Use of unauthorized spare parts

Using unauthorized spare parts can endanger personnel and damage the product or cause it to malfunction.

- Use only original spare parts or spares authorized by SCHUNK.

2.4 Ambient conditions and operating conditions

Required ambient conditions and operating conditions

Incorrect ambient and operating conditions can make the product unsafe, leading to the risk of serious injuries, considerable material damage and/or a significant reduction to the product's life span.

- Make sure that the product is used only in the context of its defined application parameters, ▶ 3 [□ 13].

2.5 Personnel qualification

Inadequate qualifications of the personnel

If the personnel working with the product is not sufficiently qualified, the result may be serious injuries and significant property damage.

- All work may only be performed by qualified personnel.
- Before working with the product, the personnel must have read and understood the complete assembly and operating manual.
- Observe the national safety regulations and rules and general safety instructions.

The following personal qualifications are necessary for the various activities related to the product:

Trained electrician	Due to their technical training, knowledge and experience, trained electricians are able to work on electrical systems, recognize and avoid possible dangers and know the relevant standards and regulations.
Qualified personnel	Due to its technical training, knowledge and experience, qualified personnel is able to perform the delegated tasks, recognize and avoid possible dangers and knows the relevant standards and regulations.
Instructed person	Instructed persons were instructed by the operator about the delegated tasks and possible dangers due to improper behaviour.
Service personnel of the manufacturer	Due to its technical training, knowledge and experience, service personnel of the manufacturer is able to perform the delegated tasks and to recognize and avoid possible dangers.

2.6 Personal protective equipment

Use of personal protective equipment

Personal protective equipment serves to protect staff against danger which may interfere with their health or safety at work.

- When working on and with the product, observe the occupational health and safety regulations and wear the required personal protective equipment.
- Observe the valid safety and accident prevention regulations.
- Wear protective gloves to guard against sharp edges and corners or rough surfaces.
- Wear heat-resistant protective gloves when handling hot surfaces.
- Wear protective gloves and safety goggles when handling hazardous substances.
- Wear close-fitting protective clothing and also wear long hair in a hairnet when dealing with moving components.

2.7 Notes on safe operation

Incorrect handling of the personnel

Incorrect handling and assembly may impair the product's safety and cause serious injuries and considerable material damage.

- Avoid any manner of working that may interfere with the function and operational safety of the product.
- Use the product as intended.
- Observe the safety notes and assembly instructions.
- Do not expose the product to any corrosive media. This does not apply to products that are designed for special environments.
- Eliminate any malfunction immediately.
- Observe the care and maintenance instructions.
- Observe the current safety, accident prevention and environmental protection regulations regarding the product's application field.

2.8 Transport

Handling during transport

Incorrect handling during transport may impair the product's safety and cause serious injuries and considerable material damage.

- When handling heavy weights, use lifting equipment to lift the product and transport it by appropriate means.
- Secure the product against falling during transportation and handling.
- Stand clear of suspended loads.

2.9 Malfunctions

Behavior in case of malfunctions

- Immediately remove the product from operation and report the malfunction to the responsible departments/persons.
- Order appropriately trained personnel to rectify the malfunction.
- Do not recommission the product until the malfunction has been rectified.
- Test the product after a malfunction to establish whether it still functions properly and no increased risks have arisen.

2.10 Disposal

Handling of disposal

The incorrect handling of disposal may impair the product's safety and cause serious injuries as well as considerable material and environmental harm.

- Follow local regulations on dispatching product components for recycling or proper disposal.

2.11 Fundamental dangers

General

- Observe safety distances.
- Never deactivate safety installations.
- Install the provided protective product in the danger zone before switching on the product.
- Remove the energy supplies before installation, modification, maintenance, or adjustment work. Ensure there is no residual energy in the system.
- Do not move parts by hand while the energy supply is connected.
- Do not reach into the movement area of the product during operation.

2.11.1 Protection during handling and assembly

Incorrect handling and assembly

Incorrect handling and assembly may impair the product's safety and cause serious injuries and considerable material damage.

- Have all work carried out by appropriately qualified personnel.
- For all work, secure the product against accidental operation.
- Observe the relevant accident prevention rules.
- Use suitable assembly and transport equipment and take precautions to prevent jamming and crushing.

Incorrect lifting of loads

Falling loads may cause serious injuries and even death.

- Stand clear of suspended loads and do not step into their swiveling range.
- Never move loads without supervision.
- Do not leave suspended loads unattended.

2.11.2 Protection during commissioning and operation

Falling or violently ejected components

Falling and violently ejected components can cause serious injuries and even death.

- Take appropriate protective measures to secure the danger zone.
- Never step into the danger zone during operation.

2.11.3 Protection against dangerous movements

Unexpected movements

Residual energy in the system may cause serious injuries while working with the product.

- Switch off the energy supply, ensure that no residual energy remains and secure against inadvertent reactivation.
- The faulty actuation of connected drives may cause dangerous movements.
- Operating mistakes, faulty parameterization during commissioning or software errors may trigger dangerous movements.
- Never rely solely on the response of the monitoring function to avert danger. Until the installed monitors become effective, it must be assumed that the drive movement is faulty, with its action being dependent on the control unit and the current operating condition of the drive. Perform maintenance work, modifications, and attachments outside the danger zone defined by the movement range.
- To avoid accidents and/or material damage, human access to the movement range of the machine must be restricted. Limit/prevent accidental access for people in this area due through technical safety measures. The protective cover and protective fence must be rigid enough to withstand the maximum possible movement energy. EMERGENCY STOP switches must be easily and quickly accessible. Before starting up the machine or automated system, check that the EMERGENCY STOP system is working. Prevent operation of the machine if this protective equipment does not function correctly.

2.11.4 Protection against electric shock

Work on electrical equipment

Touching live parts may result in death.

- Work on the electrical equipment may only be carried out by qualified electricians in accordance with the electrical engineering regulations.
- Lay electrical cables properly, e. g. in a cable duct or a cable bridge. Observe standards.

- Before connecting or disconnecting electrical cables, switch off the power supply and check that the cables are free of voltage. Secure the power supply against being switched on again.
- Before switching on the product, check that the protective earth conductor is correctly attached to all electrical components according to the wiring diagram.
- Check whether covers and protective devices are fitted to prevent contact with live components.
- Do not touch the product's terminals when the power supply is switched on.

Possible electrostatic energy

Components or assembly groups may become electrostatically charged. When the electrostatic charge is touched, the discharge may trigger a shock reaction leading to injuries.

- The operator must ensure that all components and assembly groups are included in the local potential equalisation in accordance with the applicable regulations.
- While paying attention to the actual conditions of the working environment, the potential equalisation must be implemented by a specialist electrician according to the applicable regulations.
- The effectiveness of the potential equalisation must be verified by executing regular safety measurements.

2.11.5 Protection against magnetic and electromagnetic fields

Work in areas with magnetic and electromagnetic fields

Magnetic and electromagnetic fields can lead to serious injuries.

- Persons with pace-makers, metal implants, metal shards, or hearing aids require the consent of a physician before entering areas in which components of the electric drive and control systems are mounted, started up, and operated.
- Persons with pace-makers, metal implants, metal shards, or hearing aids require the consent of a physician before entering areas in which magnetic grippers or motor parts with permanent magnets are stored, repaired, or assembled.
- Do not operate high-frequency or radio devices in the proximity of electric components of the drive system and their feed lines.

If the use of such devices is necessary:

When starting up the electric drive and control system, check the machine or automated system for possible failures when such systems are used at different intervals and in different states of the control system. A special additional EMC test may be necessary if the system has a high risk potential.

3 Technical data

3.1 Type key

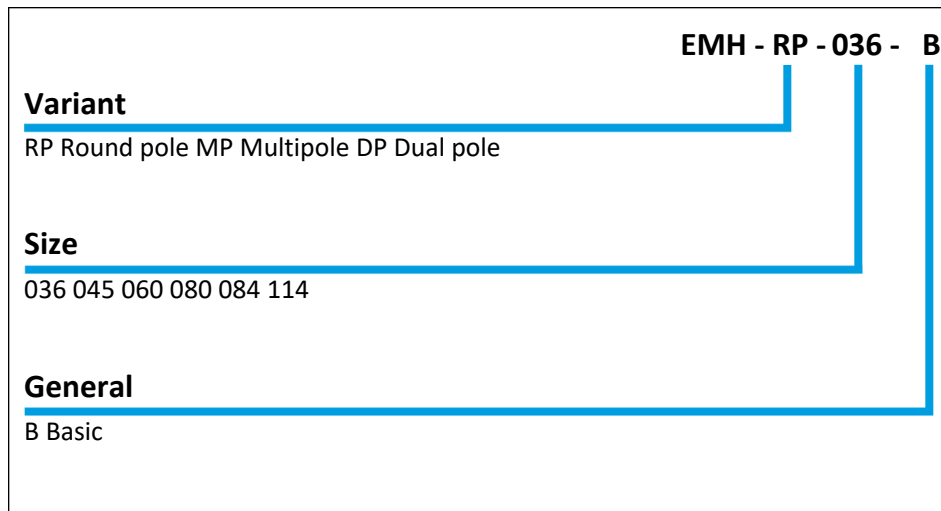

Type key

3.2 Name plate

The name plate is located on the housing:

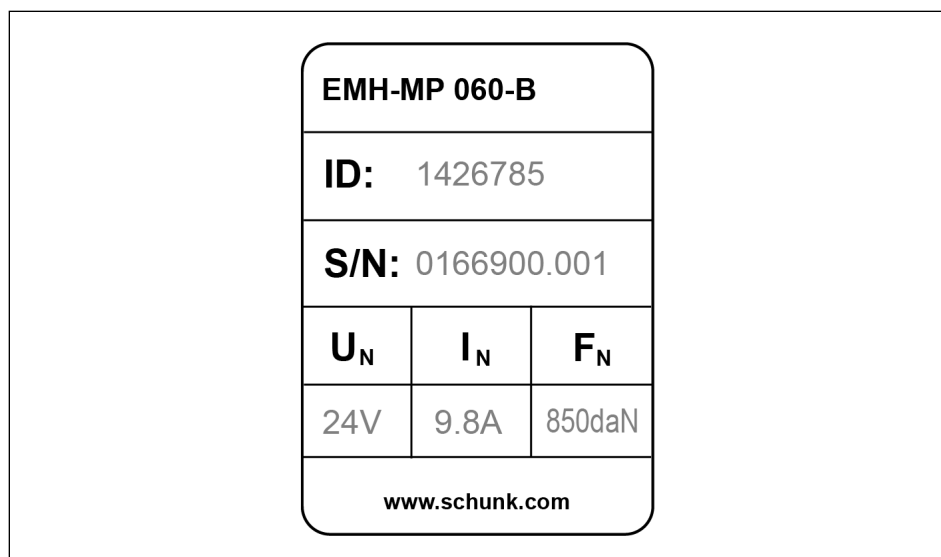

Name plate

Information	Description
EMH	Product designation
ID	SCHUNK ID
S/N	Product serial no.
U _N	Rated voltage (mains)
I _N	Rated current (mains)
F _N	Holding force

Do not remove the name plate. When consulting with SCHUNK, always specify serial and ID numbers.

3.3 Basic Data

3.3.1 Variant EMH-RP

Designation	EMH-RP			
	036-B	045-B	084-B	114-B
Dimensions XxYxZ [mm]	64 x 64 x 128	64 x 64 x 128	128 x 128 x 157	128 x 128 x 157
Weight [kg]	1	1.5	6.5	8
Magnetic induction [gauss]	6200	6700	5300	5800
Magnetic surface [cm ²]	6.08	10.75	41.25	81.97
Number of poles	2, concentric			
Load capacity for horizontal magnetic surface [kg]	8.5	22.5	89	175.5
Maximum holding force [daN]	53.0	136.0	537.0	1055.0
Increased product temperature * at 5 / 15 activations per minute [° C]	10 / 25	11 / 28	14 / 37	20 / 45
Activation time [ms]	300	300	500	700
Rated voltage [V DC]	24			
Max. current power [A]	3.1	3.8	6.1	7.1
Rated current logic [mA]	≤ 150	≤ 150	≤ 150	≤ 150
IP protection class	52			
Noise emission [dB(A)]	≤ 70			
Max. permissible product temperature [° C]	+90			
Ambient temperature [°C]				
Min.	+5			
Max.	+50			
Air humidity [%]				
Min.	30			
Max.	80			

* Increased module temperature tested on material 1.0037 with 20 mm workpiece thickness, ground surface and complete coverage of the magnetic surface.

More technical data is included in the catalog data sheet. Whichever is the latest version.

3.3.2 Variant EMH-MP

Designation	EMH-MP
	060-B
Dimensions XxYxZ [mm]	80 x 64 x 141
Weight [kg]	2
Magnetic induction [gauss]	2400
Magnetic surface [cm ²]	15.36
Number of poles	4, parallel multipole
Load capacity for horizontal magnetic surface [kg]	14
Maximum holding force [daN]	85
Increased product temperature * at 5 / 15 activations per minute [° C]	6 / 16
Activation time [ms]	200
Rated voltage [V DC]	24
Max. current power [A]	9.8
Rated current logic [mA]	≤ 150
IP protection class	52
Noise emission [dB(A)]	≤ 70
Max. permissible product temperature [° C]	+90
Ambient temperature [°C]	
Min.	+5
Max.	+50
Air humidity [%]	
Min.	30
Max.	80

* Increased module temperature tested on material 1.0037 with 20 mm workpiece thickness, ground surface and complete coverage of the magnetic surface.

More technical data is included in the catalog data sheet. Whichever is the latest version.

3.3.3 Variant EMH-DP

Designation	EMH-DP
	080-B
Dimensions XxYxZ [mm]	88 x 66 x 147
Weight [kg]	3
Magnetic induction [gauss]	3300
Magnetic surface [cm ²]	33.6
Number of poles	2, parallel dual pole

Technical data

Designation	EMH-DP
	080-B
Load capacity for horizontal magnetic surface [kg]	19
Maximum holding force [daN]	114
Increased product temperature * at 5 / 15 activations per minute [° C]	20 / 50
Activation time [ms]	500
Rated voltage [V DC]	24
Max. current power [A]	9
Rated current logic [mA]	≤ 150
IP protection class	52
Noise emission [dB(A)]	≤ 70
Max. permissible product temperature [° C]	+90
Ambient temperature [°C]	
Min.	+5
Max.	+50
Air humidity [%]	
Min.	30
Max.	80

* Increased module temperature tested on material 1.0037 with 20 mm workpiece thickness, ground surface and complete coverage of the magnetic surface.

More technical data is included in the catalog data sheet. Whichever is the latest version.

4 Design and description

4.1 Design

4.1.1 Variant EMH-RP

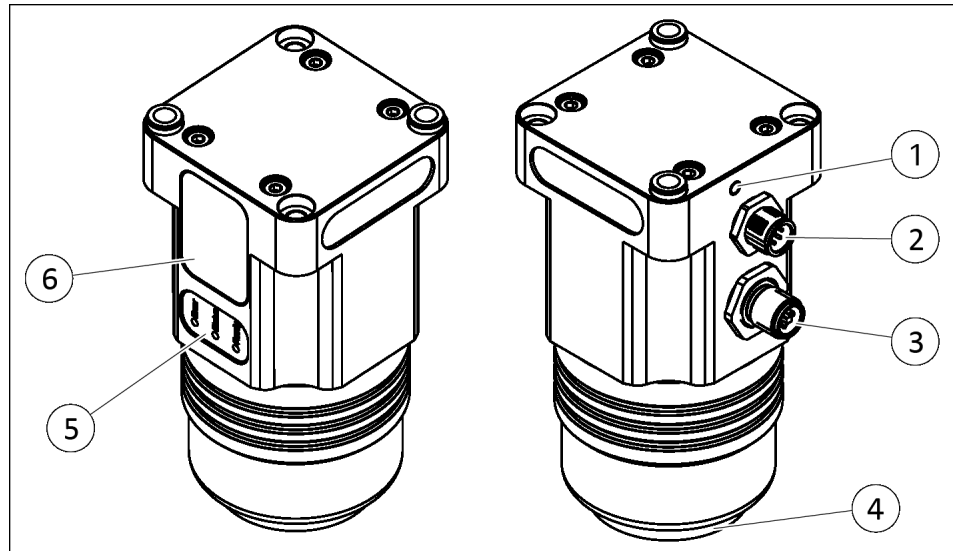

Electric permanent magnetic gripper EMH-RP

1	Ground connection (thread)
2	Logic connection (connector), communication via digital I/O interface
3	Power connection (connector)
4	Magnetic surface
5	LED status display <ul style="list-style-type: none"> • Error: flashes red if there is a malfunction. The flashing pattern indicates the type of malfunction, ▶ 7 [□ 32]. • Status: lights up yellow in the "Magnetized" state. • Ready: lights up green in the "Product ready for operation" state.
6	Name plate (not shown)

4.1.2 Variant EMH-MP

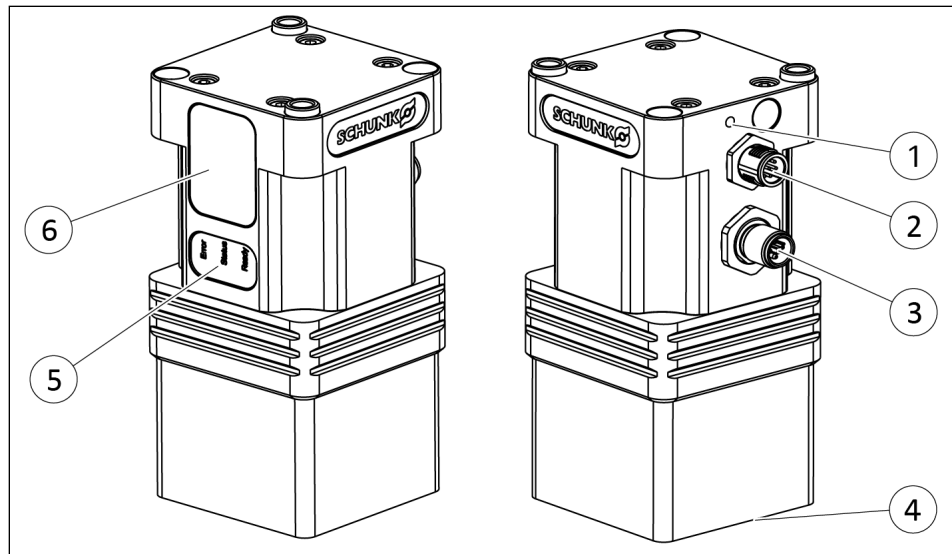

Electric permanent magnetic gripper EMH-MP

1	Ground connection (thread)
2	Logic connection (connector), communication via digital I/O interface
3	Power connection (connector)
4	Magnetic surface
5	<p>LED status display</p> <ul style="list-style-type: none"> • Error: flashes red if there is a malfunction. The flashing pattern indicates the type of malfunction, ▶ 7 [□ 32]. • Status: lights up yellow in the "Magnetized" state. • Ready: lights up green in the "Product ready for operation" state.
6	Name plate (not shown)

4.1.3 Variant EMH-DP

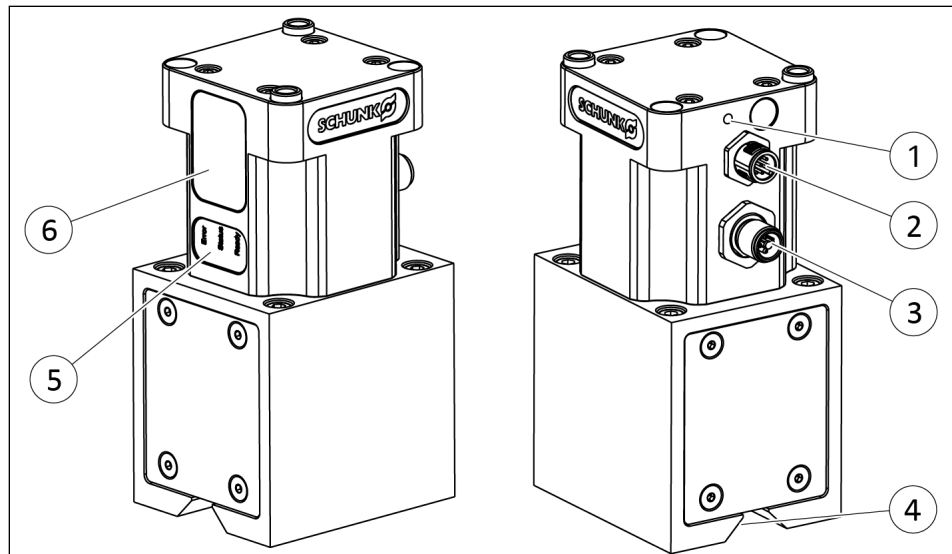

Electric permanent magnetic gripper EMH-DP

1	Ground connection (thread)
2	Logic connection (connector), communication via digital I/O interface
3	Power connection (connector)
4	Magnetic surface
5	LED status display <ul style="list-style-type: none"> • Error: flashes red if there is a malfunction. The flashing pattern indicates the type of malfunction, ▶ 7 [□ 32]. • Status: lights up yellow in the "Magnetized" state. • Ready: lights up green in the "Product ready for operation" state.
6	Name plate (not shown)

4.2 Description

The product is an electric permanent magnetic gripper for the energy-efficient handling of ferromagnetic workpieces. The workpieces are free from interfering contours allowing access from five sides and are also reliably held in emergency stop scenarios. The integrated controller communicates directly with the superordinate control system. Three LEDs on the product indicate the current status of operational readiness and magnetization. When a workpiece is held, a sensor monitors the attachment of the workpiece to the magnetic surface.

The functional principle is based on the combination of AlNiCo and neodymium magnets: in the deactivated state, the magnetic flux of the AlNiCo magnets passes through the neodymium magnets and closes the magnetic circuit via the steel gripper base body. To activate the system, an electric current pulse is conducted through the coil. This reverses the polarity of the AlNiCo magnets so that the magnetic circuit is closed by the ferromagnetic workpiece to be gripped.

The poles of the product are arranged differently depending on the variant:

- EMH-RP: concentric
- EMH-MP: parallel multipole
- EMH-DP: parallel dual pole

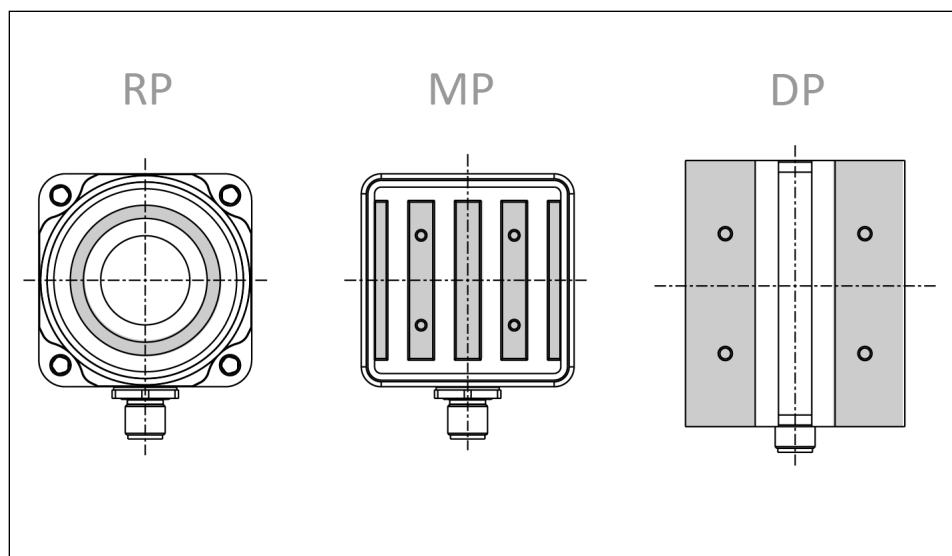

Pole arrangement

The required power is provided by selecting the suitable holding force level. The permissible load bearing capacity for a horizontal magnetic surface must be adhered to, ▶ 3 [13].

Any residual magnetism remaining in the workpiece (remanence) can be measured with an optionally available gaussmeter.

4.3 Magnetic suitability of the workpiece material

The product is design to hold almost all ferromagnetic materials. The attainable holding force depends on the magnetic resistance and thus on the chemical composition of the respective workpiece material, among other factors. Accordingly, with some ferromagnetic materials a reduction in the nominal holding force of more than 30% can be expected.

The following table shows a few examples of empirical values:

Material	Efficiency
Conventional steel (Fe 360)	100%
Ferromagnetic crude steel (C10 – C15)	90%
Tool, case hardening and sectional steels	70 - 80%
Magnetic stainless steel	65%
Cast iron	50%

In addition, material alloys can cause residual magnetism to remain in the workpiece, which significantly reduces the holding force.

Negative impact of heat treatment processes

Heat treatment processes can substantially change the magnetic characteristics of a ferromagnetic material. When methods such as forging, hardening, tempering or sintering are used, the suitability of the treated workpiece needs to be tested separately.

Examples of unsuitable materials

Handling workpieces made of materials such as the following is not possible:

- Aluminum and its alloys
- Bronze
- Brass
- Non-magnetic cast iron
- Some stainless steels (e.g. austenitic), which are only slightly magnetizable after being hardened by plastic deformation.
- Non-metallic materials

Note: if you have questions about the magnetic suitability of a workpiece, contact SCHUNK.

4.4 Factors influencing the holding force

Apart from the magnetic characteristics of the workpiece material, the attainable holding force is dependent on the following influencing factors:

Dimensions

The contact surface of the workpiece must be large enough to cover at least two poles on the product with different polarity. Only then can the magnetic circuit be closed and the holding force generated.

Contact surface

The attainable holding force is greatest when the contact surface of the workpiece is at least as big as the magnetic surface of the product.

Air gap

Uneven or dirty contact surfaces increase the distance (air gap) between the workpiece and the product. The attainable holding force is greatest when the air gap or its distribution over the contact surface is kept as small as possible. Air gaps also need to be taken into account if, due to production reasons, a higher surface quality cannot be achieved.

Workpiece thickness

For very thin workpieces (e.g. metal sheets) the maximum available holding force cannot be used due to physical reasons. Bending can also reduce the usable contact surface and thus the effect of the holding force. The resulting peeling effects can also counteract the holding force.

Heating

Each activation increases the internal temperature of the product. Overheating reduces the magnetic characteristics and can destroy the product. The following criteria must therefore be met:

- The residual heat of the workpiece corresponds to the permissible ambient temperature, ▶ 3 [13].
- The number of activations per minute is set in such a way that the maximum permissible product temperature is not reached.

Movement energy

When moving the workpiece, acceleration forces counteract the holding force. The forces exerted by the machine/system must be significantly less than the holding force attainable with the respective workpiece.

Note: if you have questions about the holding force, contact SCHUNK.

5 Assembly

5.1 Installing and connecting



⚠ WARNING

Risk of injury from the product falling during assembly and operation !

- Make sure that the product is securely mounted on the machine/system

1. Check the flatness of the mounting surface, ▶ 5.2 [□ 23].
2. Screw the product to the machine/system, ▶ 5.2 [□ 23].
3. Connect all electric cables, ▶ 5.3 [□ 24].
4. If necessary, mount pole extension, ▶ 5.4 [□ 26].

5.2 Mechanical connection

Evenness of the mounting surface

The values apply to the whole mounting surface to which the product is mounted.

Requirements for evenness of the mounting surface (Dimensions in mm)

Edge length	Permissible unevenness
< 100	< 0.02
> 100	< 0.05

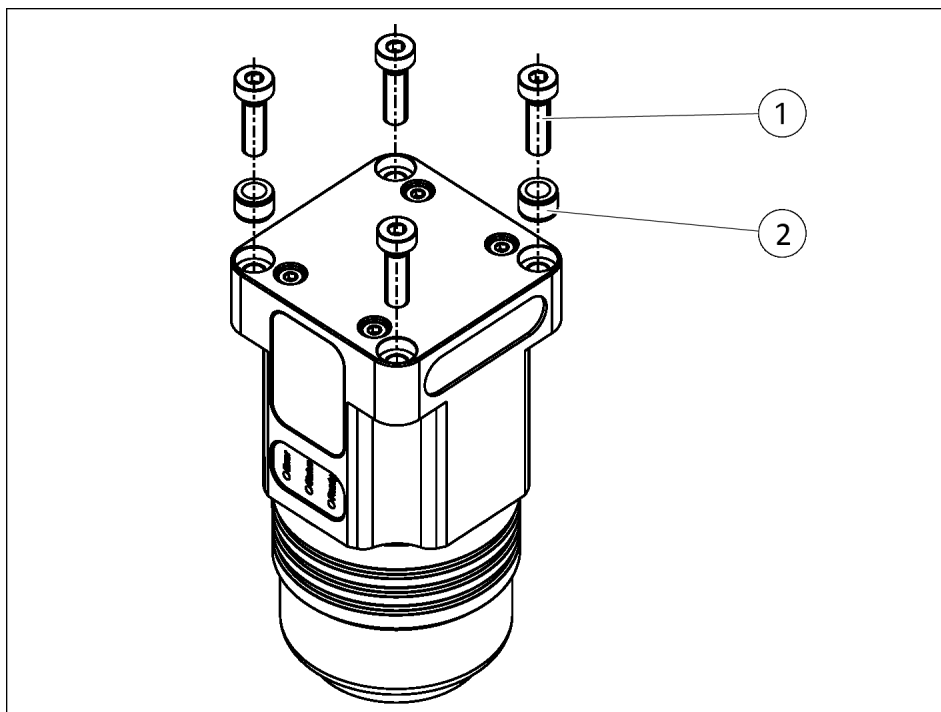

Mechanical connection (schematic diagram)

- Secure the product to the machine/system with four screws (1) and two centering sleeves (2) and pay attention to the following values:

EMH-RP

Mounting material EMH-RP

Item	Designation	EMH-RP			
		036-B	045-B	084-B	114-B
1	Mounting screw (4 [pce.])				
	Thread	M6	M6	M10	M10
	Max. depth of engagement [mm]	20	20	20	20
	Mounting screw strength class	8.8			
2	Centering sleeve (2 [pce.])	∅ 10	∅ 10	∅ 14	∅ 14

EMH-MP

Mounting material EMH-MP

Item	Designation	EMH-MP
		060-B
1	Mounting screw (4 [pce.])	
	Thread	M6
	Max. depth of engagement [mm]	20
	Mounting screw strength class	8.8
2	Centering sleeve (2 [pce.])	∅ 10

EMH-DP

Mounting material EMH-DP

Item	Designation	EMH-DP
		080-B
1	Mounting screw (4 [pce.])	
	Thread	M6
	Max. depth of engagement [mm]	20
	Mounting screw strength class	8.8
2	Centering sleeve (2 [pce.])	∅ 10

5.3 Electrical connection

NOTICE

Damage due to faulty connection!

A faulty connection can cause damage to the product.

- Observe the pin allocation of the connecting terminals.
- Make sure that all components are grounded correctly.

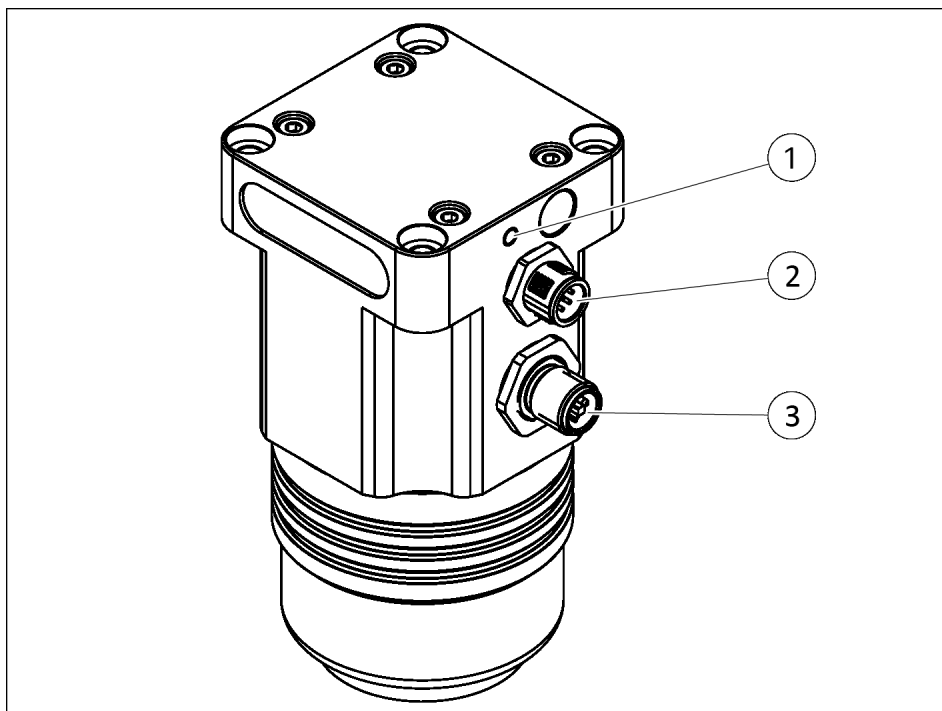

Electrical connection

1. Screw the grounding cable into the ground connection (1).
2. Connect the socket of the logic cable to the logic connection (2).
3. Connect the socket of the power cable to the power connection (3).

The cables are not included in the scope of delivery, for permissible cable specifications, see catalog data sheet EMH.

5.3.1 Power connection pin allocation

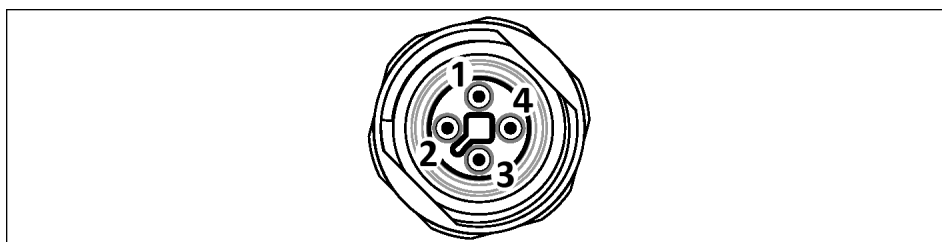

Power connection

Pin	Function	Type
1	Logic power supply (+24 VDC)	Input
2	GND power	
3	GND logic	
4	Power supply (+24 VDC)	

5.3.2 Logic connection pin allocation

NOTICE

Material damage due to incorrect grounding!

Permanent damage to the electronics possible!

- Ensure reliable equipotential bonding.
To do this, always connect the pin 3 (GND) with the grounding of the higher-level control.

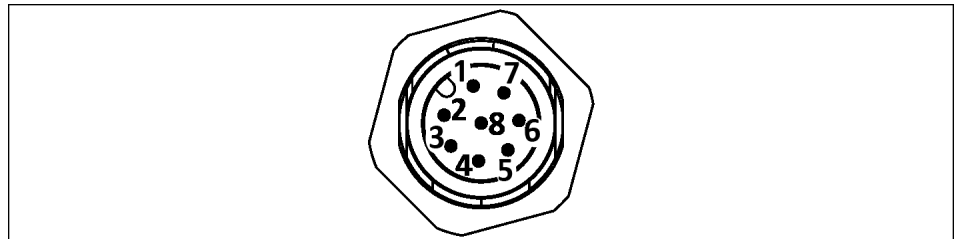

Logic connection

Pin	Function	Type
1	Magnetization ON	Input
2	Magnetization OFF	
3	Ground	GND
4	Message "Workpiece available"	Output
5	Message "Malfunction"	
6	Message "Magnetization status"	
7	Force signal A *	Input
8	Force signal B *	

* Defines the holding force level, ► 6.1 [□ 29].

5.4 Installing the pole extension (optional)

NOTE

Use of a pole extension reduces the permissible load capacity by up to 50%.

Pole extensions are only available for the variants EMH-MP and EMH-DP. The assembly of a pole extension can improve the secure holding of round workpieces, for example.

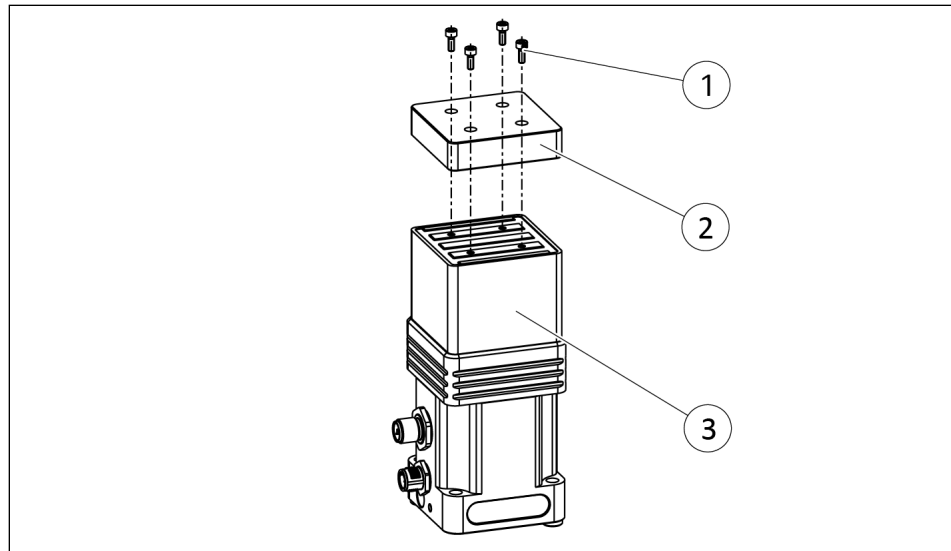

Pole extension (schematic diagram using EMH-MP as an example)

1. During assembly, observe the following dimensions and tightening torques; these differ depending on the size.
2. Screw the pole extension (2) onto the magnetic pole (3) using mounting screws (1).

Item	Designation	EMH	
		MP 060-B	DP 080-B
1	Mounting screw thread	M3	M4
	Max. depth of engagement [mm]	8	11
	Tightening torque [Nm]	1.28	2.97

6 Commissioning

- **Observe all notes in this chapter when commissioning and making adjustments on the system side of the product.**



⚠ DANGER

Danger from electric voltage!

Touching live parts may result in death.

- Switch off the power supply before any assembly, adjustment or maintenance work and secure against being switched on again.
- Only qualified electricians may perform electrical installations.
- Check if de-energized, ground it and hot-wire.
- Cover live parts.



⚠ DANGER

Risk of injury due to magnetic fields!

The integrated electric permanent magnets can pose a risk to people with an active or passive implant.

- People with pacemakers or active or passive implants are prohibited from entering the area of the magnetic field.



⚠ WARNING

Danger of crushing due to magnetically attracted tools!

Tools may be attracted by strong magnetic fields and cause severe injuries.

- Only work in deactivated and demagnetized state.



⚠ WARNING

Risk of burns through contact with hot surfaces!

Surfaces of components can heat up severely during operation. Skin contact with hot surfaces causes severe burns to the skin.

- For all work in the vicinity of hot surfaces, wear safety gloves.
- Before carrying out any work, make sure that all surfaces have cooled down to the ambient temperature.



⚠ WARNING

Risk of injury due to loss of workpiece!

A holding force that is too low can lead to the loss of a workpiece and serious injuries during handling.

- Test workpiece suitability for each type of workpiece separately.
- Increase the holding force if necessary.
- Observe the maximum permissible load capacity, ▶ 3 [□ 13].
- Avoid overheating the product. If necessary, reduce the number of activations per minute.

6.1 Adjusting the holding force

The required holding force is adjusted before each magnetization by the system-side setting (value = 1) or by turning off (value = 0) the force signals A and B:

Selecting the holding force level

Holding force level	Percentage of max. holding force	Force signal A *	Force signal B *
Holding force level 1	approx. 15%	1	1
Holding force level 2	approx. 25%	1	0
Holding force level 3	approx. 35%	0	1
Holding force level 4	100%	0	0

*Pin allocation, ▶ 5.3.2 [□ 26]

6.2 Signal sequence "Product magnetization"

- When adjusting the system-side "Product magnetization" process, observe the following signal sequence:

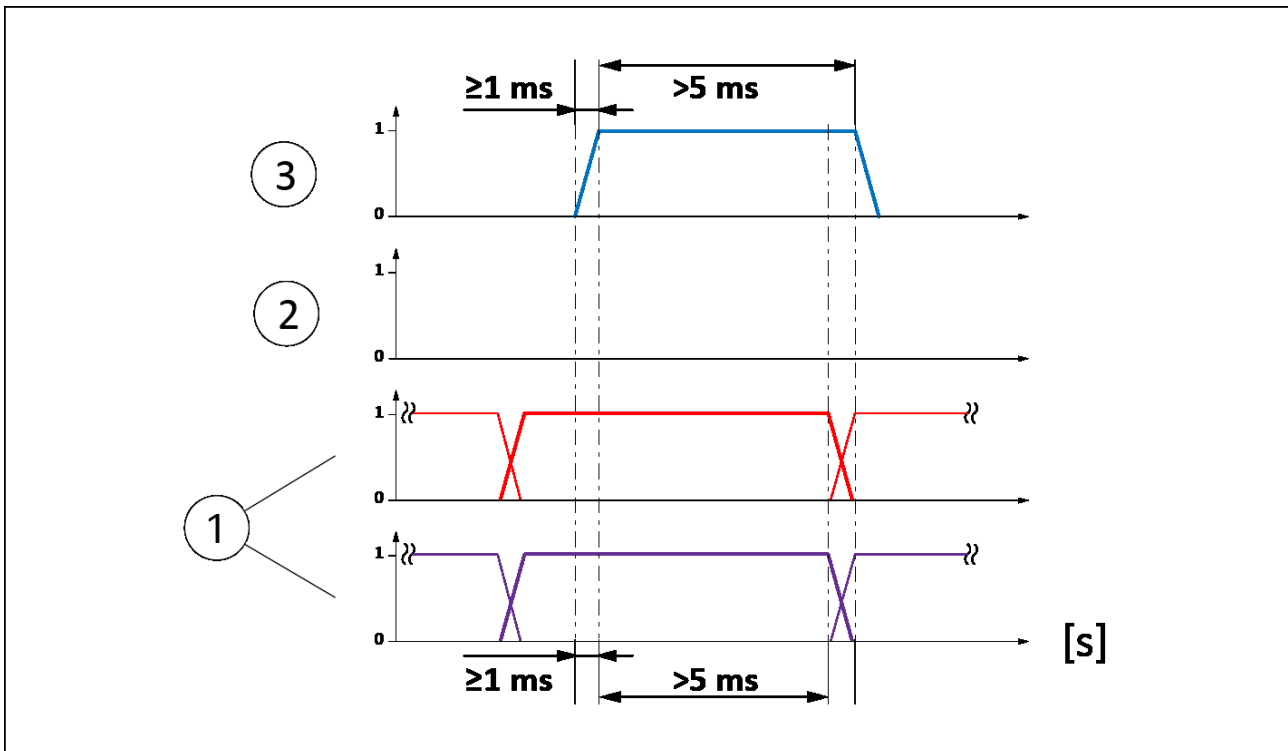

Signal sequence during the "Product magnetization" process

1	<p>Force signal A and force signal B: adjust the required holding force level by switching on or off, ▶ 6.1 [□ 29]. Note: set the force signals in time before the magnetization starts. The setting should remain unchanged until the "Magnetization" signal is switched off.</p>
2	<p>"Demagnetization" signal: ensure that the "Demagnetization" signal is switched off for the total magnetization time needed.</p>
3	<p>"Magnetization" signal: switch on the "Magnetization" signal and leave it switched on for at least 6 ms. Note: the magnetization of the product is only complete once the activation time has elapsed. The duration of the activation time depends on the size, ▶ 3 [□ 13].</p>

6.3 Signal sequence "Product ready for operation"

The "Product ready for operation" signal is always switched on. If the signal switches off, then there is an error, such as a cable breakage.

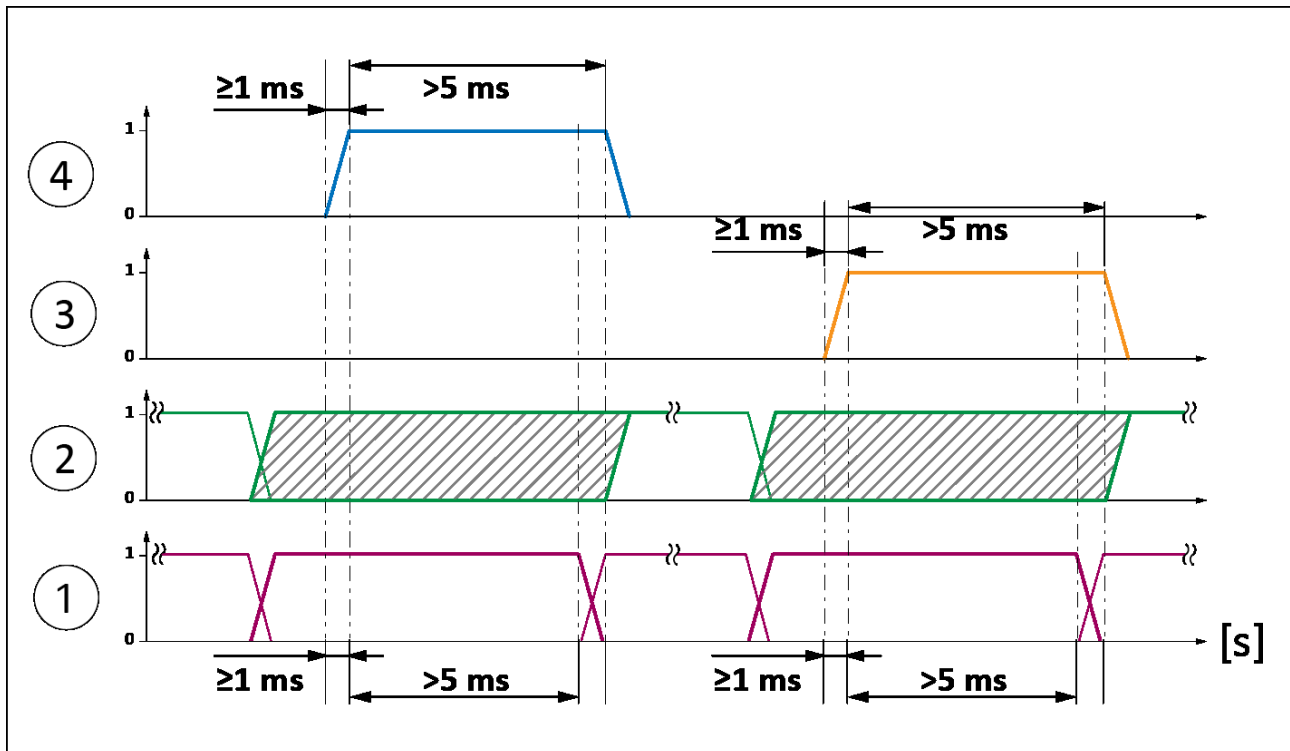

Signal sequence "Product ready for operation"

1	Force signals A and B, ▶ 6.1 [29].
2	"Product ready for operation" signal: during the "Magnetization" and "Demagnetization" processes, the signal retains the status that was last valid prior to setting the force signals. The status is updated after approx. 7 ms at the earliest, when the respective process is complete.
3	"Demagnetization" signal
4	"Magnetization" signal

7 Troubleshooting

7.1 Product remains inoperable even after the power supply is turned on

Possible cause	Corrective action
Cable connected incorrectly.	Check connection. Check control cabinet and ECG.
Fault circuit interrupter trips.	Check the product connection to ground connection.
Product and ECG are not compatible.	Check compatibility, max. permitted number of magnetic grippers and max. permitted cable length (20 m) to the magnetic gripper (see catalog datasheet EGM).

7.2 LED Ready does not light up

Possible cause	Corrective action
Logic / power connection without contact	Check the plug connection on the product.
	Check the product, lines and connections for damage.
Cable breakage	Check the cables and replace if necessary

7.3 LED Error flashes

Malfunctions are indicated by the flashing red **Error** LED. Each flashing signal is repeated after a short pause until the message is acknowledged or the malfunction has been rectified:

Flashing signal	Type of malfunction	Corrective action
LED flashes once.	Power supply error	Check the lines and connections for damage.
LED flashes twice.	Magnetization error	Check that the notes on magnetization and holding force have been adhered to.
LED flashes three times.	Demagnetization error	Check the notes on demagnetization.
LED flashes four times.	Product temperature error	Max. permissible product temperature is exceeded; allow the product to cool down.
LED flashes five times.	System error	Contact SCHUNK.

7.4 Workpiece is detached from the product

Possible cause	Corrective action
Product is not performing the magnetization process at all or not correctly.	Check the product, lines and connections for damage.
	Check the activation time and correct if necessary. Before activation, the magnetic surface must lie completely against the workpiece.
	Check the type (ramp) and duration commands and correct if necessary, ▶ 6.2 [□ 29]
The holding force is not sufficient.	Check the magnetic surface and contact surface of the workpiece for air gaps and clean if necessary. If required, change product positioning on the workpiece.
	Select a higher holding force level and repeat the magnetization process if necessary, ▶ 5.3.2 [□ 26].
	Check that the workpiece complies with the technical data, ▶ 3 [□ 13].
	Check workpiece suitability, ▶ 4.4 [□ 21].

7.5 Demagnetization was not performed correctly.

Possible cause	Corrective action
Workpiece has excessive residual magnetism and does not detach properly.	Perform the demagnetization process once again.
	Check the lines and connections for errors and damage. Ensure that the voltage supply is correct.

8 Maintenance

8.1 Maintenance intervals

Maintenance interval	Maintenance work
Before each use	Clean the magnetic surface of the product.
Regularly	Clean the product and check for damage, especially for material accumulation. Replace the product if necessary.

8.2 Check and repair the product

NOTICE

Damage caused by faulty disassembly and assembly!

Incorrect disassembly and assembly can cause damage to the product and/or accessories.

- The product and/or accessories may only be checked and repaired by SCHUNK.

11 UKCA declaration of Conformity

Manufacturer/
Distributor SCHUNK Intec Limited
 Clamping and gripping technology
 3 Drakes Mews, Crownhill
 MK8 OER Milton Keynes

Product designation: Electric permanent magnetic gripper EMH
ID number 1351485, 1351490, 1351496, 1351499, 1426785, 1475116

We hereby declare on our sole authority that the product meets the requirements of the following directives at the time of the declaration.

The declaration is rendered invalid if modifications are made to the product.

- **Electromagnetic Compatibility Regulations 2016**
- **Low Voltage Directive 2014/35/EU**
- **RoHS Directive 2011/65/EU**

Applied harmonized standards, especially:

EN ISO 12100:2010 Safety of machinery - General principles for design -
 Risk assessment and risk reduction

EN 60204-1: 2006-09 + Safety of machinery - Elektrical equipment of machines
A1: 2009-02

Person authorized to compile the technical documentation:
Marcel Machado, address: refer to manufacturer's address

Signed for and on behalf of: SCHUNK GmbH & Co. KG



Dr.-Ing. Manuel Baumeister,
Technology & Innovation

Lauffen/Neckar, November 2022

12 UKCA declaration of incorporation

in accordance with the Supply of Machinery (Safety) Regulations 2008.

Manufacturer/
Distributor SCHUNK Intec Limited
 Clamping and gripping technology
 3 Drakes Mews, Crownhill
 MK8 OER Milton Keynes

We hereby declare that on the date of the declaration the following partly completed machine complied with all basic safety and health regulations found in the "Supply of Machinery (Safety) Regulations 2008".

The declaration shall be rendered invalid if modifications are made to the product.

Product designation: Electric permanent magnetic gripper / EMH / electric
ID number 1351485, 1351490, 1351496, 1351499, 1426785, 1475116

The partly completed machine may not be put into operation until it has been confirmed that the machine into which the partly completed machine is to be installed complies with the provisions of the "Supply of Machinery (Safety) Regulations 2008".

Applied harmonized standards, especially:

EN ISO 12100:2010 Safety of machinery - General principles for design -
 Risk assessment and risk reduction

The manufacturer agrees to forward on demand the relevant technical documentation for the partly completed machinery in electronic form to national authorities.

The relevant technical documentation according to Annex VII, Part B, belonging to the partly completed machinery, has been created.

Person authorized to compile the technical documentation:
Marcel Machado, address: refer to manufacturer's address

Lauffen/Neckar, November 2022



Dr.-Ing. Manuel Baumeister,
Technology & Innovation

13 Annex to declaration of Incorporation

in accordance with 2006/42/EC, Appendix II, no. 1 B

as well as

in accordance with the Supply of Machinery (Safety) Regulations 2008.

1. Description of the basic safety and health protection requirements, as per 2006/42/EC, Annex I and per the Supply of Machinery (Safety) Regulations 2008, that apply to and are fulfilled for the scope of the incomplete machine:

Product designation	Electric permanent magnetic gripper
Type designation	EMH
ID number	1351485, 1351490, 1351496, 1351499, 1426785, 1475116

To be provided by the System Integrator for the overall machine	↓
Fulfilled for the scope of the partly completed machine	↓
Not relevant	↓

1.1	Essential Requirements		
1.1.1	Definitions	X	
1.1.2	Principles of safety integration	X	
1.1.3	Materials and products	X	
1.1.4	Lighting	X	
1.1.5	Design of machinery to facilitate its handling	X	
1.1.6	Ergonomics	X	
1.1.7	Operating positions		X
1.1.8	Seating		X

1.2	Control Systems		
1.2.1	Safety and reliability of control systems	X	
1.2.2	Control devices	X	
1.2.3	Starting	X	
1.2.4	Stopping	X	
1.2.4.1	Normal stop	X	
1.2.4.2	Operational stop	X	
1.2.4.3	Emergency stop	X	
1.2.4.4	Assembly of machinery	X	
1.2.5	Selection of control or operating modes	X	
1.2.6	Failure of the power supply		X

1.3	Protection against mechanical hazards		
1.3.1	Risk of loss of stability		X
1.3.2	Risk of break-up during operation		X

1.3	Protection against mechanical hazards			
1.3.3	Risks due to falling or ejected objects			X
1.3.4	Risks due to surfaces, edges or angles		X	
1.3.5	Risks related to combined machinery			X
1.3.6	Risks related to variations in operating conditions			X
1.3.7	Risks related to moving parts		X	
1.3.8	Choice of protection against risks arising from moving parts			X
1.3.8.1	Moving transmission parts		X	
1.3.8.2	Moving parts involved in the process			X
1.3.9	Risks of uncontrolled movements			X
1.4	Required characteristics of guards and protective devices			
1.4.1	General requirements			X
1.4.2	Special requirements for guards			X
1.4.2.1	Fixed guards			X
1.4.2.2	Interlocking movable guards			X
1.4.2.3	Adjustable guards restricting access			X
1.4.3	Special requirements for protective devices			X
1.5	Risks due to other hazards			
1.5.1	Electricity supply		X	
1.5.2	Static electricity		X	
1.5.3	Energy supply other than electricity		X	
1.5.4	Errors of fitting		X	
1.5.5	Extreme temperatures			X
1.5.6	Fire			X
1.5.7	Explosion			X
1.5.8	Noise			X
1.5.9	Vibrations			X
1.5.10	Radiation	X		
1.5.11	External radiation	X		
1.5.12	Laser radiation	X		
1.5.13	Emissions of hazardous materials and substances			X
1.5.14	Risk of being trapped in a machine	X		
1.5.15	Risk of slipping, tripping or falling	X		
1.5.16	Lightning			X
1.6	Maintenance			
1.6.1	Machinery maintenance		X	
1.6.2	Access to operating positions and servicing points		X	
1.6.3	Isolation of energy sources		X	

1.6	Maintenance			
1.6.4	Operator intervention		X	
1.6.5	Cleaning of internal parts		X	
1.7	Information			
1.7.1	Information and warnings on the machinery		X	
1.7.1.1	Information and information devices		X	
1.7.1.2	Warning devices		X	
1.7.2	Warning of residual risks		X	
1.7.3	Marking of machinery	X		
1.7.4	Instructions	X		
1.7.4.1	General principles for the drafting of instructions	X		
1.7.4.2	Contents of the instructions	X		
1.7.4.3	Sales literature	X		
	The classification from Annex 1 is to be supplemented from here forward.			
2	Supplementary essential health and safety requirements for certain categories of machinery			X
2.1	Foodstuffs machinery and machinery for cosmetics or pharmaceutical products			X
2.2	Portable hand-held and/or guided machinery			X
2.2.1	Portable fixing and other impact machinery			X
2.3	Machinery for working wood and material with similar physical characteristics			X
3	Supplementary essential health and safety requirements to offset hazards due to the mobility of machinery		X	
4	Supplementary essential health and safety requirements to offset hazards due to lifting operations		X	
5	Supplementary essential health and safety requirements for machinery intended for underground work			X
6	Supplementary essential health and safety requirements for machinery presenting particular hazards due to the lifting of persons		X	

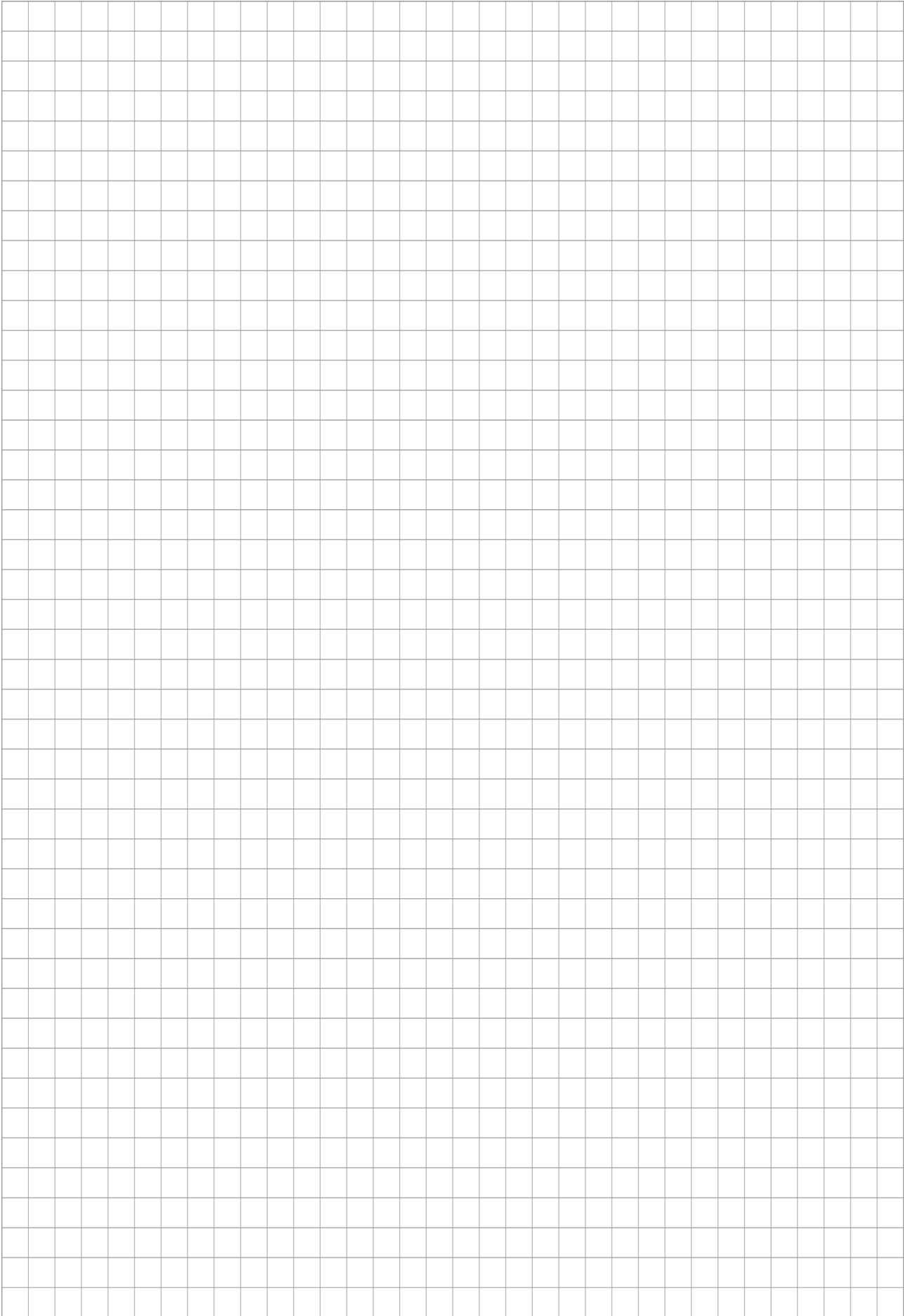

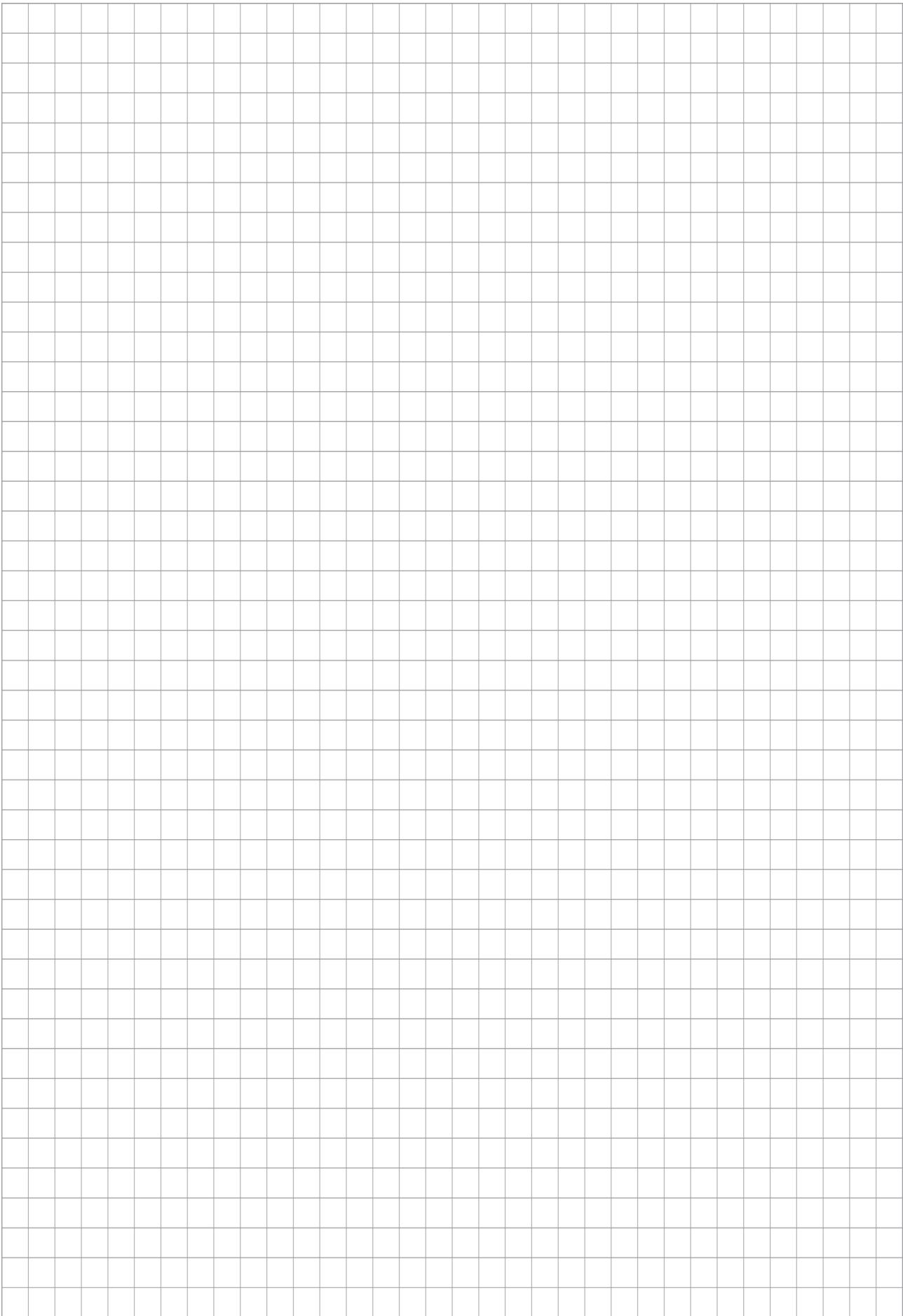

SCHUNK GmbH & Co. KG
Clamping and gripping technology

Bahnhofstr. 106 - 134
D-74348 Lauffen/Neckar
Tel. +49-7133-103-0
Fax +49-7133-103-2399
info@de.schunk.com
schunk.com

Folgen Sie uns | *Follow us*

